

ECSS-E-10A

19 April 1996



Space Engineering

System Engineering

ECSS Secretariat
ESA-ESTEC
Requirements & Standards Division
Noordwijk, The Netherlands

Published by: ESA Publications Division,
ESTEC, P.O. Box 299,
2200AG Noordwijk,
The Netherlands.

Price: 35 Dutch Guilders

Printed in the Netherlands

Copyright 1996 © by the European Space Agency for the members of ECSS

Foreword

This standard is one of the series of ECSS Standards intended to be applied together for the management, engineering and product assurance in space projects and applications. ECSS is a cooperative effort of the European Space Agency, National Space Agencies and European industry associations for the purpose of developing and maintaining common standards.

Requirements in this standard are defined in terms of what must be accomplished, rather than in terms of how to organise and perform the necessary work. This allows existing organisational structures and methods to be applied where they are effective, and for the structures and methods to evolve as necessary without rewriting the standards.

The formulation of this standard takes into account the existing ISO 9000 family of documents.

This standard has been prepared by the ECSS Standards Working Group, reviewed by the ECSS Technical Panel and approved by the ECSS Steering Board.

(This page is intentionally left blank)

Contents List

Foreword	3
1 Scope	7
1.1 Introduction	7
1.2 Relationship with other standards	11
2 References	13
2.1 Normative references	13
3 Definitions and abbreviations	15
3.1 Definitions	15
3.2 Abbreviations	16
4 General requirements	19
4.1 System engineering management plan	19
4.2 System engineering & control	19
4.3 Requirement engineering	23
4.4 Analysis	29
4.5 Design & configuration	32
4.6 Verification	34
4.7 System engineering interfaces	39

5	Specific requirements	43
5.1	System Engineering required inputs	43
5.2	System engineering integration & control	45
5.3	Requirement engineering	47
5.4	Analysis	49
5.5	Design and configuration	52
5.6	Verification	53
Annex A	(informative) DRD: system engineering management plan	57
Annex B	(informative) Organization of system engineering Level 3 standards	61
Annex C	(informative) System engineering documentation definitions	65

Figures

Figure 1:	System Engineering Functions	9
Figure 2:	System Engineering Process	10
Figure 3:	Space System Requirements	25
Figure 4:	Sample Specification Tree	27
Figure 5:	Basic Verification Approach	35
Figure 6:	Model Philosophy Definition Process	36

Tables

Table 1:	Typical Inputs for System Engineering	44
Table B-1:	Level 3 System Engineering Standards	61

Scope

1.1 Introduction

This standard is intended to guide the development of Systems (including hardware, software, man-in-the-loop, facilities and services) for space applications. It specifies implementation requirements for the responsible System Engineering organisation consistent with the assumption that the System Engineering process defined in Standard ECSS-E-10-01 is to be applied.

Specific objectives of this standard are to :

- a. Assist in defining, performing, managing, and evaluating System Engineering efforts to ensure that the programme has a firm organisational basis, able in principle to minimise technical risk due to uncertain understanding of scope.
- b. Facilitate minimisation of cost through avoidance of repeated organisational work, conversion between different practices and dispersions due to conflicts of interpretation of approaches to System Engineering tasks.
- c. Capture the key aspects of the Space Standardization initiatives to : better integrate requirements; implement multidisciplinary teamwork including suppliers; establish the requirements early; establish clear measurements of system responsiveness; focus on process control rather than inspection; encourage risk management rather than risk avoidance; increase teamwork and cooperation.

This Standard covers specifically each conventional phase of development of a Space System, from analysis and assembly of the user's requirements to operations and disposal.

The requirements of this Standard may be tailored for each specific space application, in line with the overall ECSS tailoring guidelines (Ref.).

For the definition of "System Engineering" see Clause 3 below. System Engineering has an integration role for the Engineering disciplines defined in Standard ECSS-E-00.

For the definition of System lower levels of decomposition, this Standard, in line with other ECSS standards, does not assume a unique terminology in the assumption that each programme may optimise its breakdown choosing from the terms defined in ECSS-E-00.

In this respect it is important to note that the guidelines herein formulated for a space “System” indeed apply, with appropriate tailoring, to a lower level of decomposition, on the grounds that products of practically any level are:

- a. the final result of an interdisciplinary process starting with the operational requirements analysis and concluding with the delivery of the verified and certified product;
- b. the result of the design integration of different parts and functions.

Figure 1 shows the boundaries of the System Engineering discipline, its relationship with Production, Operations, Product Assurance and Management disciplines and its internal partition into “Functions”:

- System Engineering Integration & Control
- Requirements Engineering
- Analysis
- Design and Configuration
- Verification

Functions do not represent a compulsory organisation requirement, but rather a useful conceptual partition of the System Engineering discipline, whereby each element (“function”) embraces tasks which are homogeneous in objective and nature, and all elements together encompass the totality of the discipline’s scope.

The organisation of requirements per functions, as in this Standard, permits the definition of clear-cut, homogeneous sets that can be easily mapped on the functional diagram of the Systems Engineering process defined in standard ECSS-E-10-01 (Figure 2), and external to which only requirements for System Engineering Interface tasks at the boundary with other disciplines remain to be defined.

The dynamic properties of this process, namely its applicability in an iterative and nested pattern across the complete span of a system life cycle, are described in detail in Standard ECSS-E-10-01 “Systems Engineering Process”.

For each function, General (i.e. principle, structural) and Specific (i.e. in the form of a discrete, verifiable task or product for a given life cycle phase) requirements are given, covering all the System Engineering activities as a means of obtaining a beneficial, nonoverburdening, programme-independent recommendation or guideline.

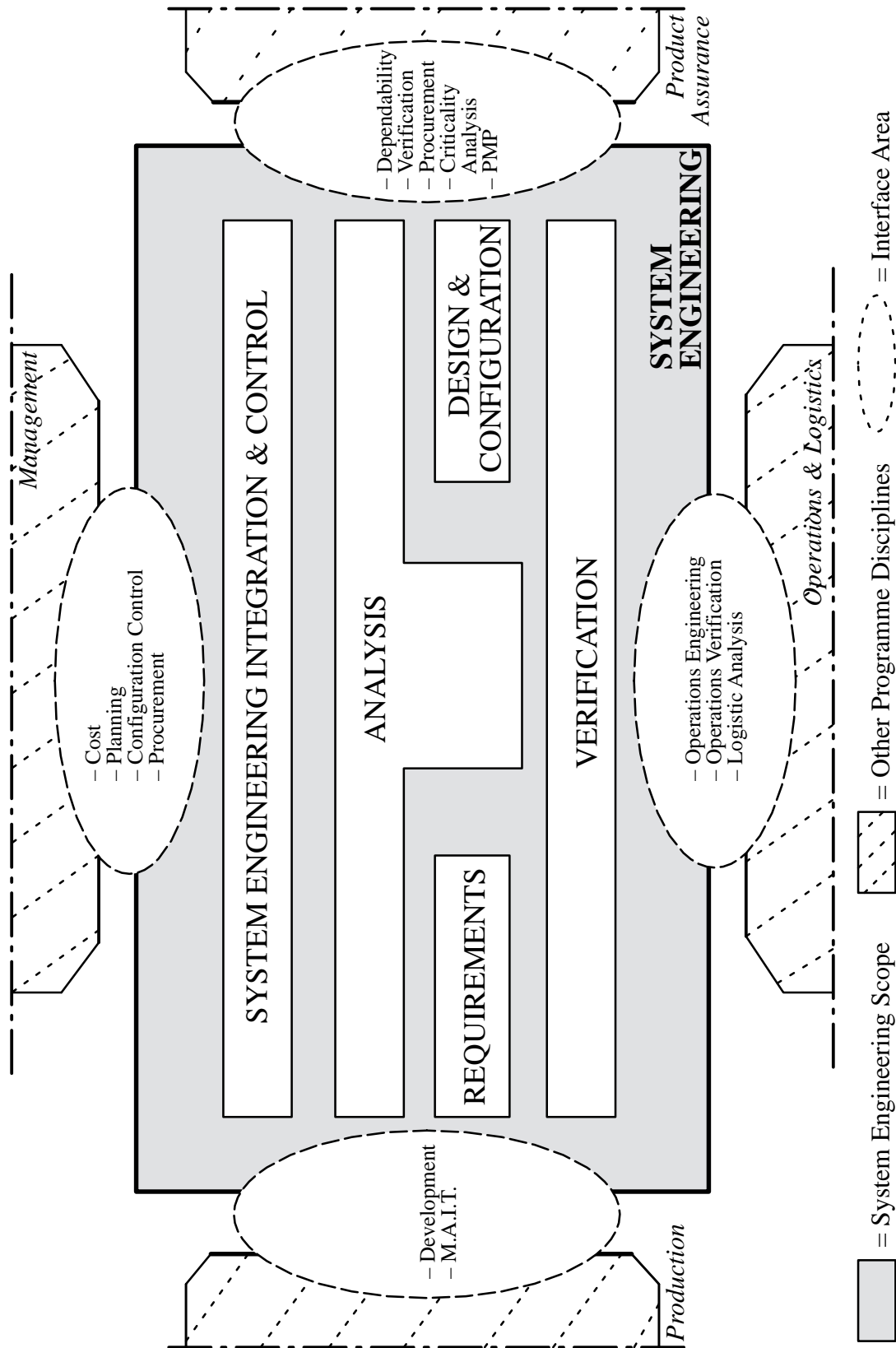

NOTE MAIT = Manufacturing, Assembly, Integration and Test
PMP = Parts, Materials, Processes

Figure 1: System Engineering Functions

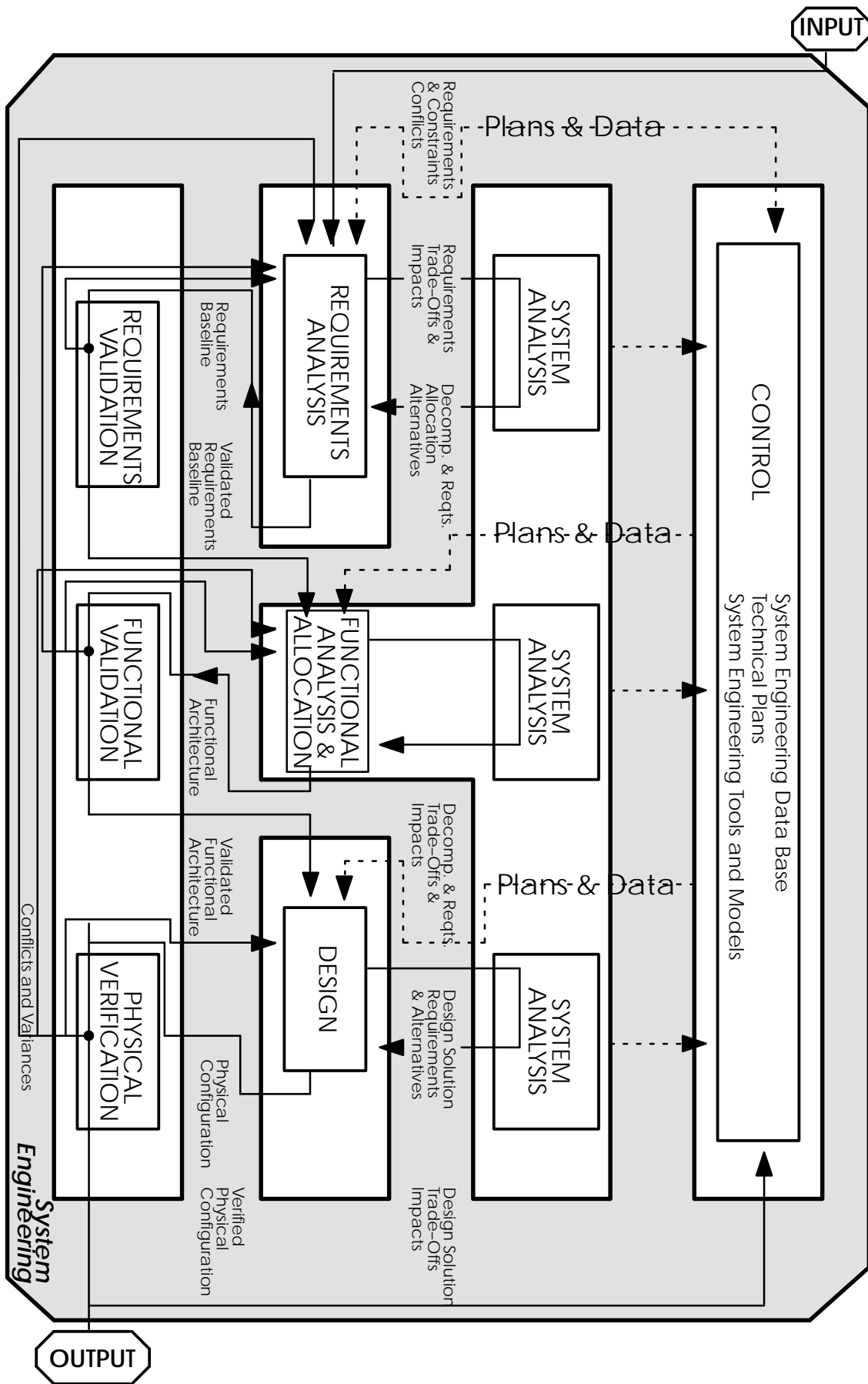

Figure 2: System Engineering Process

1.2 Relationship with other standards

For the overall definition of “System Engineering” as a discipline of Engineering in Space projects this Standard refers to Standard ECSS-E-00 (Engineering of Space Programmes), while for the theory of System Engineering this Standard refers to Standard ECSS-E-10-01 (Systems Engineering Process).

It is in ECSS-E-10-01 that “System Engineering” is explained as a mechanism for proceeding from interpretation of the customer’s requirements to an optimised product by steadily applying a wide-ranging attention to product requirements, extending to all details of the user’s needs, produceability constraints and life cycle aspects, essentially through an organised concurrent engineering practice. This takes place through iteration and nesting of a proper routine of analysis/synthesis, typical of a comprehensive system approach, within and across all levels of integration and all phases of a system life cycle.

Standard ECSS-E-10-01 defines and describes this routine in a high-level, product-independent, phase-independent and essentially intellectual way.

This standard instead aims at providing a practical, space-focused implementation of the above, developing it into a set of discrete definitions and requirements. These constitute a common reference or “checklist” of maximum utility for organising and conducting, with respect of the above principles, the engineering activities of a space system project or for participating as customer or supplier at any level of decomposition.

The System Engineering activities addressed in ECSS-E-10

- integrate specifically the activities of other Engineering disciplines covered by ECSS-E-xx standards (ECSS-E-20 Electrical and Electronic, ECSS-E-30 Mechanical, ECSS-E-40 Software, ECSS-E-50 Communications, ECSS-E-60 Control Systems, ECSS-E-70 Ground Systems and Operations);
- ensure a functional interfacing with Management and Quality activities covered by ECSS-M-xx and ECSS-Q-xx standards, in particular:
 - System Engineering is submitted to ECSS-M-10 Project Breakdown Structure, ECSS-M-20 Project organisation (it is part of it), ECSS-M-30 Project Phasing;
 - System Engineering is fully interfaced with and complies with the requirements of ECSS ECSS-M-40 Configuration Management, ECSS-M-50 Information/ Documentation, ECSS-M-60 Cost and Schedule Management, and ECSS-M-70 Integrated Logistics Support;
 - System Engineering integrates in the product design and implementation process the inputs of the Product Assurance organisation, namely Dependability, Safety, Component Control, Materials, Mechanical Parts and Processes provisions.
 - System Engineering contributes to the implementation of the Product Assurance organisation by integrating the ECSS-Q-xx requirements and facilities within the system engineering activities.

(This page is intentionally left blank)

References

2.1 Normative references

This ECSS Standard incorporates, by dated or undated reference, provisions from other publications. These normative references are cited at the appropriate place in the text and publications are listed hereafter. For dated references, subsequent revisions of any of these apply to this ECSS standard only when incorporated in it by revision. For undated references the latest edition of the publication referred to applies.

ECSS-E-00	Space Engineering – Policy and Principles
ECSS-E-10-01	Space Engineering – System Engineering Process
ECSS-M-00	Space Project Management – Policy and Principles
ECSS-M-30	Space Project Management – Project Phasing and Planning
ECSS-M-40	Space Project Management – Configuration Management
ECSS-M-70	Space Project Management – Integrated Logistic Support
ECSS-P-001	Glossary of Terms

(This page is intentionally left blank)

Definitions and abbreviations

3.1 Definitions

For the purposes of this standard, the definitions given in ECSS-P-001 Issue 1 apply. In particular, it should be noted that the following terms have a specific definition for use in ECSS standards.

Acceptance

Analysis

Configuration Baseline

Design

Development

Element

Equipment

Inspection

Margin

Product tree

Qualification

Requirements

Specification

Subsystem

System

Test

Verification

For definitions of the following terms refer to ECSS-E-10-01 "System Engineering Process" :

Design-to-Cost

Effectiveness analysis

Integration

System Engineering

The following terms and definitions are specific to this standard and shall be applied.

“Hybrid Model Philosophy

Model philosophy representing a compromise between prototype and protoflight approaches. It is based on a protoflight model on which a partial protoflight qualification test campaign is carried out. Specific qualification test in the critical areas are carried out on dedicated models.”

“Protoflight Model Philosophy

Model philosophy based on a single model (Protoflight Model) to be flown after it has been subjected to a protoflight qualification and acceptance test campaign. Typical philosophy for projects with no technology critical design and compromise permitted to reduce cost accepting a medium risk.”

“Requirement Traceability

A requirement attribute that links each single requirement to its higher level requirement(s) inside the requirement set.”

This eventually makes possible the derivation of a requirement tree which demonstrates the coherent flow-down of the requirements.

“System Engineering

The application of System Engineering theory to a specific system”

“Time line analysis

Analytical task conducted to determine the time sequencing between two or more events and to define any resulting time requirements.”

“Test effectiveness

The number of failures per spacecraft found in the test of interest divided by the total number of failures which are possible to be found in all the acceptance test campaign and during the first 45 days of flight.”

3.2 Abbreviations

The following abbreviations are defined and used within this standard.

Abbreviation	Meaning
AIV	Assembly, Integration and Verification
AOCS	Attitude & Orbit Control System
CAD	Computer Aided Design
DJF	Design Justification File
ECSS	European Cooperation for Space Standardization
EEE	Electronic, Electrical, Electromechanical
EGSE	Electric Ground Support Equipment
EMC	Electro-Magnetic Compatibility
ICD	Interface Control Document
ILS	Integrated Logistic Support
IRD	Interface Requirement Document
LRR	Launch Readiness Review
LSA	Logistic Support Analysis
PA	Product Assurance
PDR	Preliminary Design Review
QR	Qualification Review
R&D	Research and Development

S E	System Engineering
SEMP	System Engineering Management Plan
SRR	System Requirement Review
TBD	To Be Defined
TRB	Test Review Board
VCD	Verification Control Document

(This page is intentionally left blank)

General requirements

4.1 System engineering management plan

The system supplier response to this Standard shall be a System Engineering Management Plan (SEMP) which describes the approaches, techniques, tools, organisation, planning and scheduling of the technical effort necessary to accomplish the project objectives. The SEMP demonstrates the implementation of the System Engineering functions mentioned hereafter and the logic and consistency of the development activity planning. The SEMP, usually approved by the customer, describes all foreseen contributions to the SE effort and shall be updated during the course of the project (with the approval of the responsible customer and supplier staff as necessary), to reflect any evolution in the System Engineering implementation.

The requirements for the organisation and presentation of the System Engineering Management Plan are given in Annex A to this standard.

4.2 System engineering & control

System Engineering Integration and Control ensures the integration of the various disciplines and participants throughout all the project phases in order to optimise the total definition and realisation of the system. It provides corresponding inputs to programme management.

4.2.1 System engineering management

The System Engineering organisation responsible for the design of the complete system's architecture and for the control of the Interfaces shall be capable of :

- a. planning and managing a fully integrated technical effort able to achieve the general objectives of the system with minimised risks
- b. applying the system engineering process for each level of system decomposition during each phase of the project life from top level project management down to the lowest level
- c. controlling the achievement at each project milestone through the conduct of technical reviews, risk management, data management, interface management, configuration management and verification
- d. generating models and breadboards, carrying out research and development, studies to support trade off analyses and the optimised design of the system architecture

- e. generating a product and process data package which ensures that the complete System can be produced, tested, delivered, operated, supported and properly disposed of
- f. coordinating, integrating and harmonising the planning, activities and products of all disciplines involved in space project Engineering as addressed in ECSS-E-00.
- g. ensuring that the methods and means (including software) required for each activity are available and validated at the due time
- h. ensuring that the experience gained in past and parallel activities is systematically considered in the process and in the design solutions

4.2.2 Planning

- a. System Engineering Integration and Control shall establish and maintain in the SEMP a System Engineering schedule compliant with the project master schedule.
- b. It shall provide inputs based on key events for each discipline to enable them to establish their own planning in a coordinated manner.

4.2.3 Engineering data base

- a. System Engineering Integration and Control shall set up a data base gathering all engineering data from requirements analysis and validation, functional analysis and validation, design, physical verification and system analysis.
- b. The design files and the corresponding justification files in which all decisions trade-offs and risk assessments shall be included, shall be set up in compliance with the project configuration management rules.

4.2.4 Documentation and data exchange

- a. System Engineering Integration and Control shall provide their requirements to the definition and the setting up of the documentation and data exchange system in order to ensure the System Engineering interdisciplinary work, the control of the total definition and realisation of the system, the interface management, and configuration control.
- b. System Engineering shall establish an Engineering Documentation and Data Exchange System, compatible with the overall requirements of ECSS-M-50.
- c. The Engineering Documentation and Data Exchange system should be as defined in Engineering level 3 standard TBD

4.2.5 Interface management

System interfaces can be external (with other, contiguous systems) or internal (between functions within the system).

Both can be part of an original set of requirements (Interface Requirement Document), or can be defined as outputs from functional studies. They are determined at the boundary between functions of hardware or software assemblies implemented by different engineering responsibility groups, and are normally separately specified.

- a. System Engineering Integration and Control shall establish and maintain a positive control of interfaces supported by Interface Control Documents (ICD'S) and interface control procedures.
- b. Functional block diagrams and functional interface input/output shall be expressed in the earliest phase of the project and updated throughout its course.

Physical or functional/operational interfaces, characterised by mechanical and/or functional data/parameters, may be included.

4.2.6 Environmental engineering

- a. System Engineering shall perform environmental engineering tasks following methodologies defined in level 3 ECSS standards to ensure system robustness under environmental conditions.
- b. All combined natural or induced environmental conditions having an impact on system functions and applied during the system life cycle shall be considered, including the following environment types:
 - Climatic
 - Mechanical (vibration, shock, microvibration, acoustic)
 - EMC
 - Thermal
 - Contamination
 - Radiation
 - Atomic oxygen
 - Debris, ...
- c. Environmental conditions to be considered shall concern all relevant events during the system life cycle including:
 - Manufacturing,
 - AIV
 - Transportation, storage
 - Mission operations (launch, in-orbit,...)
 - Disposal
- d. Environmental engineering activities shall be initiated in the earlier phases of the programme.
- e. Environmental engineering activities shall be carried out within the System Engineering organisation by environmental engineering specialists.

Requirements related to environment engineering tasks are described in relevant System Engineering function requirement clauses of this standard (requirements, analysis, design, verification).

4.2.7 Human factors engineering

- a. System Engineering shall perform human factors engineering tasks following methodologies defined in level 3 standards to ensure system safety, usability and efficiency when human beings are interacting with the product.
- b. The following key points required to guarantee safety, well-being and efficiency for the human presence shall be considered :
 - Anthropometry and biomechanics (human body mechanical limitations)
 - Human performance capabilities (strength, workload etc.)
 - Climate (pressure, atmospheric composition, temperature and humidity)
 - Environment (microgravity, acoustic, vibration, radiation, contamination)
 - Crew safety (hazards)
 - Architecture (workstations, activity centres, health management, house-keeping etc.)
 - Human/Machine interfaces (Software & Hardware)
 - Extravehicular Activity and related supports
 - Procedures development & Training
- c. Human Factors engineering activities shall be started in the earliest phases of space projects.

- d. Human Factors engineers shall be part of the System Engineering organisation, Hardware, Software or Courseware detailed design requirements may be applied to or may originate from subsystem or equipment level.

4.2.8 Budget and margin philosophy

- a. Necessary design margins for technical budget uncertainties shall be defined and controlled for each level as appropriate
- b. During the life cycle of a space project, the required margins shall be reduced depending on the ratio of open/solved technical uncertainties, problems or potential development and mission risks.
- c. For the physical parameters (e.g. mass, size, tolerance, etc.) a product-oriented element or component budget shall be identified.
- d. There shall be a continuing verification of the degree of anticipated and actual achievement for these technical parameters.

4.2.9 Technology

- a. Wherever applicable systematic trade-offs of proven versus new technologies applicable shall be conducted to achieve optimised product performances.
- b. System Engineering shall take into consideration technologies' availability and sensitivity at various steps of the project.
- c. Mainly during the conceptual phase, the necessary techniques shall be assessed in terms of availability and feasibility within the defined industrial organisation cost and schedule.
- d. Any additional research or tests or any investigation required to reduce uncertainties and risks to an acceptable level shall be conducted.
- e. Where risks are high, back-ups shall be considered or more resources shall be allocated to improve the situation.
- f. Qualification of critical processes and new technologies shall be achieved in a controlled manner in line with the overall schedule.
- g. In the design phase continuous verification of readiness and efficiency of the manufacturing processes and corresponding technologies shall continue in order to detect any possible deviation from objectives.

4.2.10 Cost effectiveness

Cost effectiveness is a major driver in the programme decision process and design iteration. It is part of design to objectives, included in System Engineering trade-offs mainly addressing a cost/performance to function parameter. The design-to-cost approach includes any additional cost reduction initiatives, and defines cost-driven incentives.

- a. Cost effectiveness based on the project specific cost objective (e.g. development, or operations, or life cycle cost minimisation), shall be considered as a product design parameter, along with performance, effectiveness, capability, accuracy, size, weight, reliability, maintainability, supportability...

Cost effectiveness may be applied to a deliverable item, to total system design, to manufacturing, to operations, to procurement (acquisition) and to major modifications, in order to control and minimise cost in accordance with project requirements.

4.2.11 Risk management

- a. System Engineering shall contribute to the Risk Management process defined in ECSS-M-00 by specifically providing, and by assessing, the technical data involved in the Risk Management analyses, decision and implementation activities.

- b. This will include support to:
 - analysis of the risk causes, consequences and acceptability;
 - quantification and categorisation of the risk;
 - definition and implementation of a Risk Management Plan;
 - verification of the effects of risk-reduction actions;
 - residual risk acceptance process;
 and execution of the Logistic Support Analysis
- c. System Engineering shall consistently implement and control the selected risk reduction provisions which are within engineering's responsibility.

4.2.12 Procurement

System Engineering Integration and Control shall:

- a. ensure that manufacturing constraints are included in System Engineering trade-offs
- b. support the Engineering effort in establishing the manufacturing or purchase specifications
- c. support the make or buy decision trade-off
- d. support the procurement activities by coordinating Engineering effort.

4.2.13 Change management

- a. Change control shall be established and maintained in conformance with ECSS-M-40.
- b. At system level the complete architecture shall be submitted to change control.
- c. When a change affects interfaces and involves parties on both sides of the interface, the upper level shall ensure the compatibility of newly defined interfaces and shall take any decision, considering the benefit of the whole.
- d. System Engineering shall be the technical authority for changes raised up to project level and ensure that the same rules are applied at lower levels.
- e. System Engineering shall provide the supporting technical documentation.

4.2.14 System engineering capability assessment

The capability to perform System Engineering tasks or an activity including System Engineering studies shall be demonstrated as a minimum by :

- a. the evidence of human resources and corresponding organisation, experience and capacity to manage proposed subcontractors
- b. a System Engineering Capability Assessment which can be performed according to the standard "quality assessment procedures" and SE capability assessment guide as defined in Engineering level 3 standard TBD.

4.3 Requirement engineering

4.3.1 Responsibilities

Requirement Engineering shall be part of System Engineering, responsible for the proper interpretation of the end-customer needs, coherent and appropriate generation of system and lower assembly level specifications, and day-to-day control of the requirement status and traceability.

4.3.2 Requirement classification

4.3.2.1 Requirement generation

Space System requirements are typically identified and grouped in relationship to their primary objective in specifying the system as shown in Figure 3.

- a. When space system requirements are generated consideration shall be given to the system's functional objectives, its characteristics and interfaces, the environmental conditions under which it will perform, the quality and operational factors, the necessary support and the verification aspects, this providing operational, functional and physical views of the system and its constituents.
- b. System or operational requirements need not all be originated top down, but may be derived from a lower level, e.g. subsystem.

4.3.2.2 Requirement characteristics

To facilitate the System Engineering process, in particular the verification activities, each requirement shall be:

- a. Traceable with respect to at least one higher level requirement.
- b. Unique and associated with a proper identifier (for instance a document and para number).
- c. Single and not a combination of several requirements
- d. Verifiable using one or more approved verification methods.
- e. Unambiguous
- f. Referenced as necessary to other requirements (with applicable document and para. identification).
- g. Possibly associated with a specific title.

4.3.2.3 Requirement verification

The traceable set of technical requirements forms the basis of the verification process at each architectural level.

- a. Each requirement shall be associated with proper verification requirements.
- b. Requirement traceability shall be established and maintained along the system life cycle

4.3.2.4 Requirement criticality

Each requirement differs in importance for the system development and operation in terms of impact on cost, schedule and risks.

For this reason and to facilitate the System Engineering process:

- a. a suitable criticality factor shall be associated with each requirement, to support the requirement management activities;
- b. the requirement sensitivity shall be evaluated (i.e. the impact on implementation aspects due to critical requirement modification).

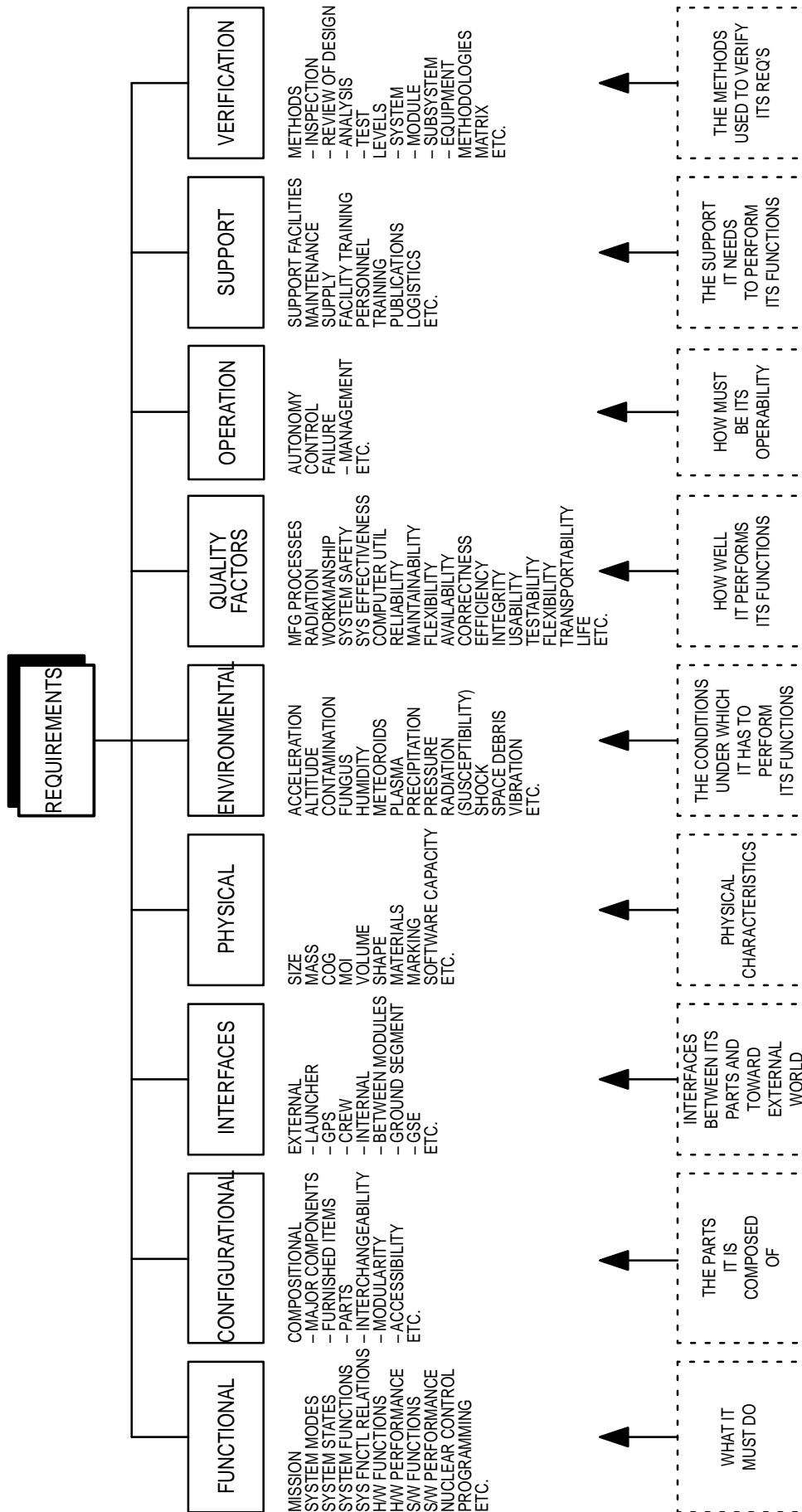

Notes: H/W = Hardware, SW = Software, GPS = Global Positioning System, GSE = Ground Segment Equipment, COG = Centre of Gravity, MOI = Moment of Inertia

Figure 3: Space System Requirements

4.3.3 Specifications

- a. The system and lower assembly level requirements shall be contained in specifications organised in a comprehensive specification tree. A sample specification tree is shown in Figure 4.
- b. Specifications should comply with Specification Practice Standard ECSS-E-10-TBD.
- c. The specifications shall be of different types depending on the characteristics of the configuration item to which they apply, including its architectural level (e.g. equipment-level specifications shall not contain mission requirements).

Subsets of end item specification requirements (e.g. support requirements) may be the subject of a dedicated discipline specification.

Interface requirements may be contained in specific Interface Requirement Documents.

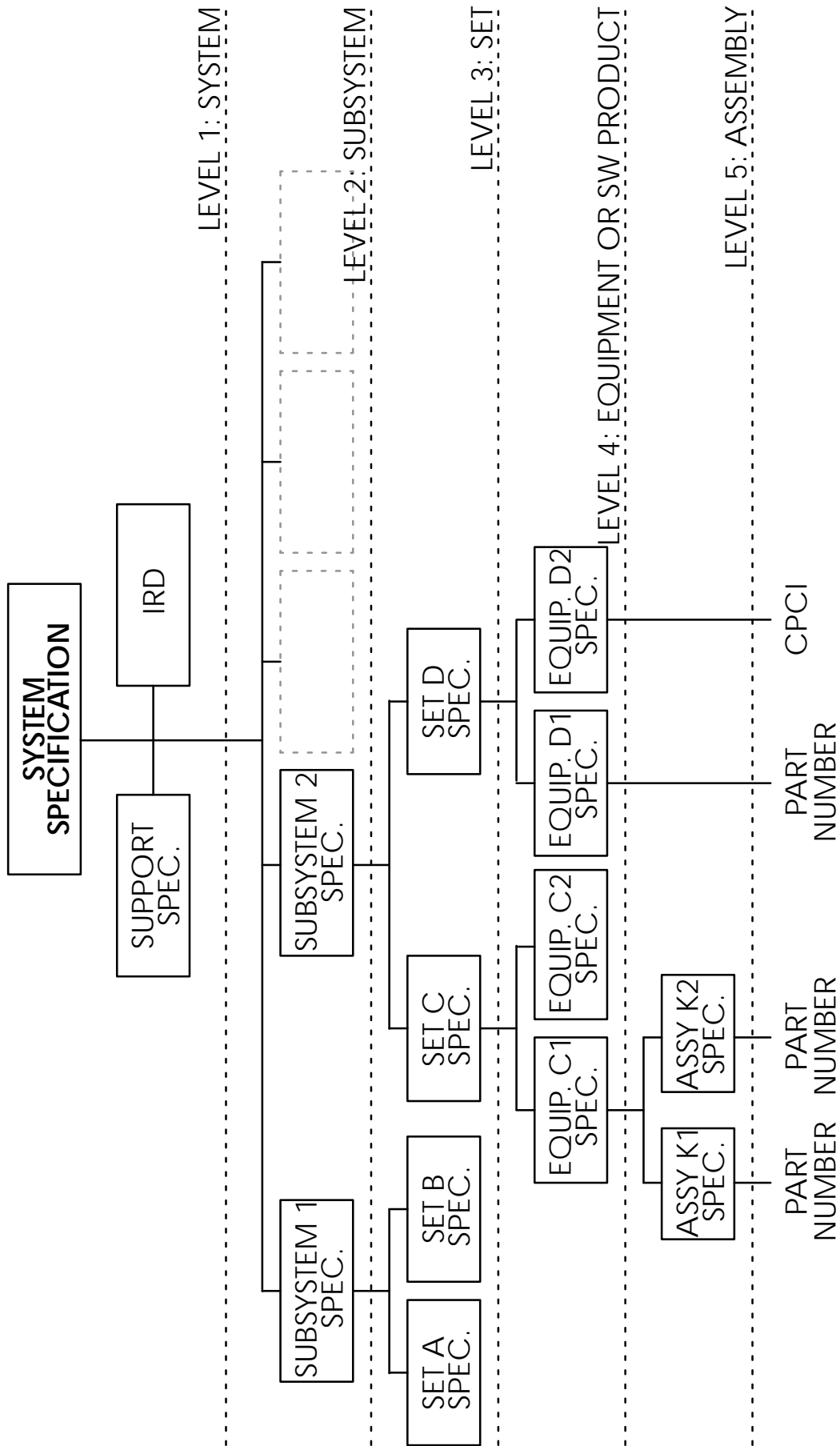

Figure 4: Sample Specification Tree

Notes: IRD = Interface Requirement Document, CPCI = Computer Program Configuration Item

4.3.4 Requirement engineering process

4.3.4.1 Process content

The Requirement Engineering process shall consist basically of the following activities: requirement analysis and validation, requirement allocation and requirement maintenance.

4.3.4.2 Requirement Analysis and Validation

- a. The customer's requirements (i.e. needs and objectives) shall be analysed in order to reach:
 1. a satisfactory understanding of the customer's expectations and agreement with the customer of a refined requirement baseline; to this effect, possible incomplete, ambiguous or contradictory requirements shall be identified and resolved with authorised customer representatives
 2. a satisfactory synthesis of responsive products and services to the requirements (see clause 4.4.5)
- b. Requirement analysis and validation shall include :
 1. assessment of different system life-profile situations from manufacturing to disposal with associated combinations of environmental conditions as well as the applicable number of occurrences and their duration.
 2. Identification of design requirements relating to the product, including the applicable statutory and regulatory requirements.
 3. Identification of constraints (e.g. limits of applicability) related to each specific requirement.
- c. The results of the requirement analysis and validation activity shall be directly fed into the process of system specification generation

4.3.4.3 Requirement allocation

- a. The system requirements shall be allocated on the basis of proper functional and system analyses to the lower level system constituents.
- b. The allocation process shall be iteratively carried out in parallel with functional and architectural analyses.
- c. The requirement flow-down shall be aimed at decreasing the level of complexity and increasing the level of detail (e.g. measurable terms, go/no-go criteria) through an added-value exercise.
- d. Existing direct requirements (e.g. some design constraints) shall be allocated to the applicable level without tailoring.

4.3.4.4 Requirement maintenance

- a. Requirements at all levels shall be maintained during the entire system life cycle.
- b. Any requirement change shall be processed and recorded in order to guarantee full visibility and traceability of the current requirement baseline.
- c. The actual requirement status shall be reported in accordance with ECSS-M-40.

4.3.5 Requirement management tools

Requirement generation, allocation and maintenance may be effectively supported by computerised tools containing a requirement data base and an application software to support requirement control, traceability and reporting.

These tools should if used be linked to the verification control and configuration control tools.

4.4 Analysis

4.4.1 Scope of analysis effort

System Engineering analyses are performed at all levels and in all domains for the purpose of resolving functional and performance requirements and constraint conflicts during requirement analysis; decomposing functional requirements and allocation performance requirements during functional analysis; evaluating the effectiveness of alternative physical element solutions and selecting the best physical solution during synthesis; assessing system effectiveness, identifying and analysing risk factors; selecting appropriate risk handling approaches; managing risk factors throughout the System Engineering effort; complementing testing evaluation and providing trade studies for assessing effectiveness, risk, cost and planning.

- a. Analysis shall be performed in all domains at all levels and in all operation modes.
- b. Analysis shall present enough information and solutions to allow the decision maker to select the best available alternatives.
- c. Analysis shall provide information by which to measure progress, evaluate alternatives, document data and decisions used and generated.
- d. Analysis shall include trade-offs, studies, effectiveness assessment, and design analyses to determine progress in satisfying technical requirements and programme objectives.

4.4.2 System analysis

- a. System analysis shall be performed during all phases of the product life cycle as necessary
- b. System analysis shall integrate mission analysis, requirements analysis, functional analysis, physical analysis and performance analysis.
- c. System analysis shall provide a rigorous quantitative basis for performance, functional and system assessments.
- d. Cost and schedule shall be analysed at each step of the product life cycle versus the system technical parameters.
- e. Mission, requirements, design, operation and support shall be analysed versus cost and schedule of the final product.
- f. The analyst shall develop, document, implement, control and maintain a method to control analytic relationship and measures of effectiveness.
- g. Critical measures of effectiveness used for decision making should be identified for technical performance measurement.
- h. System/cost-effectiveness assessments shall be used to support risk impact assessments.
- i. The analyst shall assess margins and tolerances.
- j. The analyst shall assess budgets (mass, communication links, power, on-board computer memory capacity, etc.)
- k. The analyst shall conduct time-line analysis to determine the time sequencing between two or more events and to define any resulting time requirements for assessing planning critical paths.
- l. For each relevant life cycle event, environmental conditions shall be assessed and quantified from existing standards, existing environmental data bases, laboratory tests, environmental models, or in-service measurement data.
- m. Compliance between existing environmental data bases and the project constraints shall be verified.

- n. Environment types and combinations occurring during the life cycle shall be considered on the basis of criticality with respect to System functions.
- o. The influence of environments applied during each life profile event on System function shall be assessed in terms of normal limit and extreme environment domains. For each pair of system functions and environment conditions relevant criteria qualification of the levels and limits of acceptance shall be defined.
- p. As soon as possible design induced effects, such as mutual effects and dynamic interactions between System components or the System and its external environment, shall be taken into account.
- q. Variability or statistical distribution of environmental factors shall be assessed and environmental factors applicable for design including margins for system robustness shall be derived
- r. Environment conditions for verification taking into account modelling and test accuracy and limitations shall be specified.

4.4.3 Trade studies

A trade study can be:

- **Mental:** a selection made based on the judgement of the analyst or designer which does not require the rigour of a more formal study and for which the consequences are not too important, one alternative clearly outweighs other, and/or time is not available for a more formal approach.
- **Informal:** follows the same methodology as a formal trade study but is not documented as formally since it is of less importance to the customer.
- **Formal:** formally conducted with results reviewed at technical reviews.

The analyst shall conduct or consolidate synthesis trade-off studies to:

- a. Support decisions for new products and process developments versus non-developmental product and processes.
- b. Establish System and Configuration items.
- c. Assist in selecting system concepts, designs and solutions (including people, parts and materials availability).
- d. Support material selection and make-or-buy, process, estimation and location decisions.
- e. Analyse planning critical paths and propose alternatives.
- f. Examine alternative technologies to satisfy functional/design requirements including alternatives for moderate to high risk technologies.
- g. Evaluate environmental and cost impacts of materials and processes.
- h. Evaluate alternative physical architectures to select preferred products and processes.
- i. Select standard components, techniques, services and facilities that reduce System life-cycle cost and meet System effectiveness requirements. Agencies and commercial data bases should be utilised to provide historical information used in evaluation decisions.
- j. Assess model philosophy demonstrating qualification objectives and verification goals as well as testability needs.
- k. Assess design capacity to evolve.

4.4.4 Functional analysis

- a. The analyst shall examine each primary System function to:
 1. Support the identification and definition of performance and functional requirements for the primary system functions to which system solutions shall be responsive.
 2. Support the selection of preferred product and process design requirements that satisfy those performance and functional requirements.
 3. In performing functional analysis, the analyst shall take project constraints into account, but shall not consider a design solution.
- b. From requirements analyses a validated requirement baseline shall be established which is translated into functional architecture. The functional architecture describes the functional arrangements and sequencing of subfunctions resulting from the breaking down of the set of system functions to their subfunctions.
- c. Functional analyses shall identify product and subsystem solutions to the functional requirements that lead to an optimised functional architecture.
- d. Functional analyses shall be conducted iteratively to analyse the functional requirements to determine the lower level functions required to accomplish the higher level requirement.
- e. Functional requirements shall be so arranged that lower level functional requirements are recognised as part of the higher level requirements.
- f. Functional requirements shall be logically sequenced, with input, output and functional interface (internal and external) requirements defined, and be traceable from beginning to end conditions and across their interfaces.

4.4.5 Requirement allocation analysis

From each functional requirement and interface, performance requirements are established from the highest to the lowest level. If higher level performance and functional requirements cannot be resolved to the lower level, the analyst determines performance requirements for lower level functions and evaluates alternative functional architecture.

- a. Allocatable requirements shall be progressively divided to lower level.
- b. Allocatable requirements shall be directly or indirectly allocated to subfunctions. Directly allocatable requirements such as time to perform or weight, are partitioned among subfunctions, as appropriate. Requirements which are not directly allocatable, such as range, are translated into derived performance requirements such as fuel capacity, engine efficiency, and vehicle resistance, through appropriate techniques and analyses.
- c. Nonallocatable requirements shall be applied directly to all subfunctions (e.g. constraint, material or process standard).
- d. The analyst shall document the allocation of system performance requirements to subfunctions to provide traceability and facilitate later changes.
- e. Trade studies and risk analyses shall be performed to select a balanced set of subfunctions and to allocate performance requirements to subfunctions to assure requirements balance across subfunctions and to resolve conflicts among allocated performance requirements and nonallocatable requirements.
- f. The analyst shall examine each subfunction and aggregate of subfunctions to determine the responses (outputs) of the function(s) to stimuli (inputs).
- g. Analyses shall be conducted as a means of understanding the functional behaviour of subfunctions under various conditions and checking the integrity of the functional arrangement logic.

- h. Analyses should involve the simulation or stimulation of functional models, utilising operational scenarios which expose the model to a variety of stressful and nonstressful situations which reflect anticipated operational usage and environments.

4.4.6 Analysis tools and methods

- a. The System Engineering Management Plan (SEMP) shall define the analysis tools and methods to be used during the product life cycle.
- b. Existing databases shall be used to evaluate the product (cost, technology, design, test, etc.).
- c. New data bases shall be created for the purpose of assessing the product in orbit versus ground assessment and to increase lessons learned from projects.
- d. System modelling tools, engineering modelling and simulation tools, design validation tools and measure of effectiveness and performance tools shall be preferably off-the-shelf tools rather than new development tools.
- e. Models shall be used in conjunction with analysis tools to increase confidence and produce pertinent data.
- f. Model validation procedures and results should be recorded.
- g. Engineering tools of the computer-based systems type should be connected to the Engineering data base of the programme.
- h. Analysis reporting shall include:
 - 1. clear reference of the Configuration Item baseline assumed for the analysis
 - 2. identification of the analysis constraining assumptions (e.g. environmental)
 - 3. explicit statement of basic assumptions and of analysis methods adopted
 - 4. description and justification of the mathematical models used

4.5 Design & configuration

4.5.1 Design Process

4.5.1.1 Process requirements

- a. The design process shall derive a physical architecture and design (including software), from functional analysis and requirement allocation.
- b. Synthesis shall be conducted interactively with analysis and verification to check which design output best complies with requirements
- c. In fulfilling these tasks Design and Configuration shall :
 - 1. Apply design simplicity concepts, evaluating alternatives with respect to factors such as ease of access, ready disassembly, common and noncomplex tools, decreased part counts, modularity, produceability, standardization, standardization of interfaces and especially cost.
 - 2. Demonstrate design consistency with results from risk reduction efforts.
 - 3. Identify critical parameters, and analyse their variability and solution sensitivity to the variability.
 - 4. Identify applicable process and material specifications
 - 5. Define product and process alternatives iteratively as well as required allowances for tolerances
 - 6. Define tolerance methods that facilitate inspection
 - 7. Adopt design solutions that facilitate fault detection, isolation and recovery (e.g. test points, modularity, built-in test software, feedback loops)
 - 8. Define solutions to a level of detail that enables verification that required accomplishments have been meet.

4.5.1.2 Design trade-offs

- a. Design is an iterative process whereby various concepts are evolved and evaluated against a set of design requirements. Each iterative process shall be commensurate with cost, schedule, performance and risk impacts.
- b. Design trade-off studies shall be conducted to (for example) :
 - Evaluate alternative physical and software architectures or design to select preferred solutions for products and processes.
 - Select standard components, techniques, services and facilities that reduce system life cycle cost.
 - Evaluate environmental and cost impacts of materials and processes.
 - Examine alternative technologies which could replace high-risk technologies.
 - Carry out material selection and make-or-buy decisions.

4.5.1.3 Budgets

As a part of the Design and Configuration activity :

- a. all applicable system design budgets shall be generated and maintained, reflecting the as designed status
- b. budget requirements for all system levels of decomposition shall be apportioned
- c. the margin policy defined as part of the clause 4.2.8 activity shall be applied

4.5.2 Configuration

4.5.2.1 Configuration content

- a. The output from the design shall describe the complete System functional, physical and software configuration including the lower assembly levels, budgets, interfaces and relationships between external and internal items.
- b. The level of detail of the description shall be a function of the programme phase, and in principle include at all the required assembly levels the following output :
 1. Baseline configuration definition and description throughout the applicable life cycle phases (e.g. launch, deployed, end-of-life, etc. . .)
 2. Technical input to the Product Tree and the configuration identification.
 3. Project drawing at all detail levels, including studies, engineering drawings, assembly drawings, interface drawings, manufacturing drawings etc.
 4. Life cycle resource requirements and physical characteristics (budgets : mass, inertia, c.o.g., etc.)
 5. Design input to the process documentation, material specifications, commercial items, descriptions, drawings and lists, Interface Control Documents, handling procedures;
 6. Inputs to derive the operation time lines.

4.5.2.2 Product tree

The Product Tree describes the hierarchical breakdown of a complex system into lower level as necessary to fully define the System.

- a. The Product Tree shall be structured as a "natural" breakdown of the system
- b. It shall be strictly product oriented, that is a systematic subdivision of the product into discrete and related elements of the product to be provided.

- c. The Product Tree shall provide a complete graphical overview of the entire System by its defined product items and their relationships.

4.5.2.3 Configuration baseline

A System Configuration Baseline shall be established and placed under control at defined programme points. This baseline shall record the design, data (drawings, budgets), text description and other pertinent information or decision, or clarifications made to System requirements.

4.5.2.4 Drawing tree

A drawing tree shall be generated and maintained to reflect the drawings associated with the elements of the physical architecture, in the correct hierarchical and assembly relationship.

4.5.2.5 Design definition file

The designer shall maintain a file that includes all design documents and drawings providing a detailed description (functions, interfaces, architecture) and the functional and operational characteristics of a product, to be used for development and become part of the User Manual.

4.5.2.6 Design justification file

- a. A file shall be established in the form of an assembly of justification evidence at a given time to prove that the design is optimised for all requirements expressed in the Technical Specification.
- b. The file shall identify acceptable risks, in order to ensure that the objectives achieved fulfil the target requirements and assemble information intended to justify design option selection.

4.5.3 Design tools

- a. All drawings shall be established by use of identical methods, design rules, reference coordinate systems and technical standards as agreed at System level.
- b. CAD tools shall allow selected CAD drawings to be interchangeable between different locations by suitable electronic means.

4.6 Verification

4.6.1 Verification process

Verification demonstrates, through a dedicated process, that the System meets the applicable requirements and is capable of sustaining its operational role during the project life cycle.

4.6.1.1 Verification process content

The verification process addresses all constituents of the system and is incrementally performed applying a coherent building block concept through :

- Establishing verification criteria against applicable requirements
- Deriving the planning for the associated verification activities
- Monitoring the implementation and the execution of all verification activities at all levels in all phases
- Preparing the verification close-out documentation

The typical verification process may encompass the following phases:

- development
- qualification (including possibly an in-orbit stage)
- acceptance (same as above)

- pre-launch readiness
- post-landing verification

4.6.1.2 Verification objectives

The objectives of the verification process are primarily:

- to demonstrate the qualification of design and performance, as meeting all specified requirements at all necessary levels;
- to ensure that the flight hardware and software are free from workmanship defects and acceptable for flight;
- to validate tools, procedures and personnel necessary to support the System ground and flight operations;
- to confirm System integrity and quality of performance after certain stages in the project life cycle.

4.6.1.3 Verification approach

- A verification approach shall be selected during the project's early phases by analysing the requirements to be verified taking into account design constraints and the qualification status of candidate solutions, availability and maturity of the verification tools, test and verification methodologies, programmatic constraints, cost and schedule.
- The approach shall be derived through an iteration process answering the classical set of questions: "what?", "how?", "where?", as summarised in Figure 5.

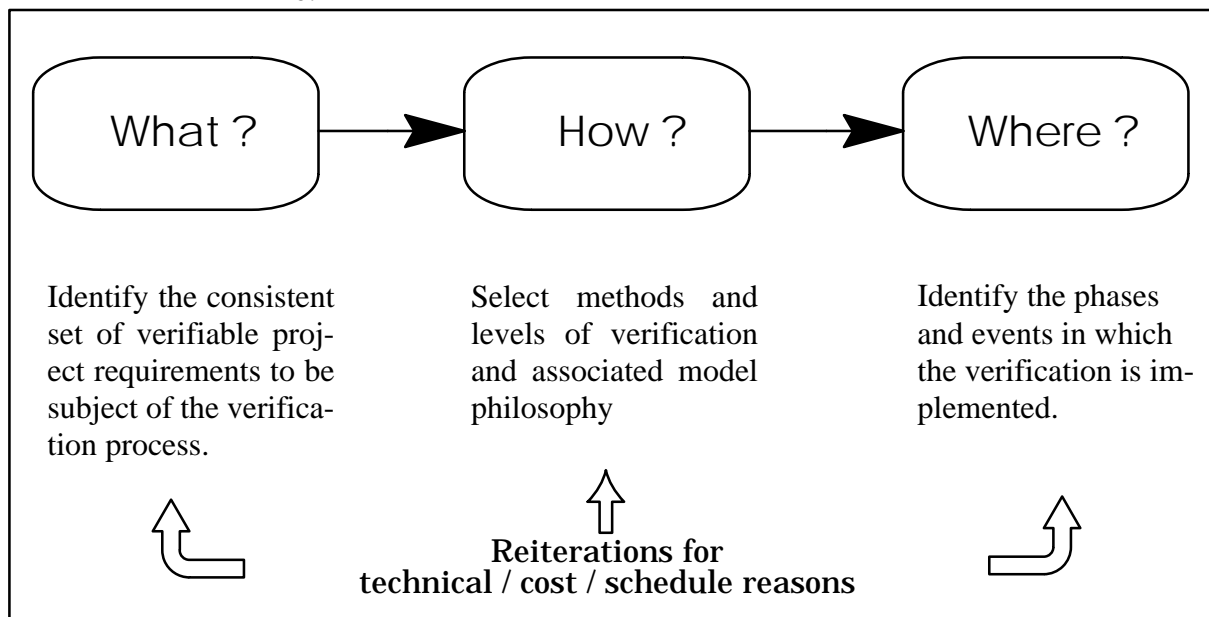

Figure 5: Basic Verification Approach

4.6.1.4 Verification methods

- The System and lower level requirements shall be verified by one or more of the following verification methods :
 - test
 - analysis
 - review of design
 - inspection
 - demonstration

- b. The verification method shall be selected according to the type and criticality of the requirement, and with the cost effectiveness of the method
- c. For each verification event, accept/reject criteria shall be defined and expressed in unambiguous, measurable terms.

4.6.1.5 Verification levels

- a. The requirement verification shall be performed incrementally at different verification levels in relationship with the product tree; typical verification levels include :
 - equipment
 - subsystem
 - system
- d. Formal close-out of qualification or acceptance at lower levels shall be a prerequisite for close-out at higher level
- e. The resulting organised data shall support the formal declaration of the achieved system verification.

4.6.1.6 Model philosophy

- a. The number of physical models (from System to lower assembly levels) shall be optimised in order to achieve a high confidence in the product verification with the shortest planning and a suitable weighting of cost and risk.

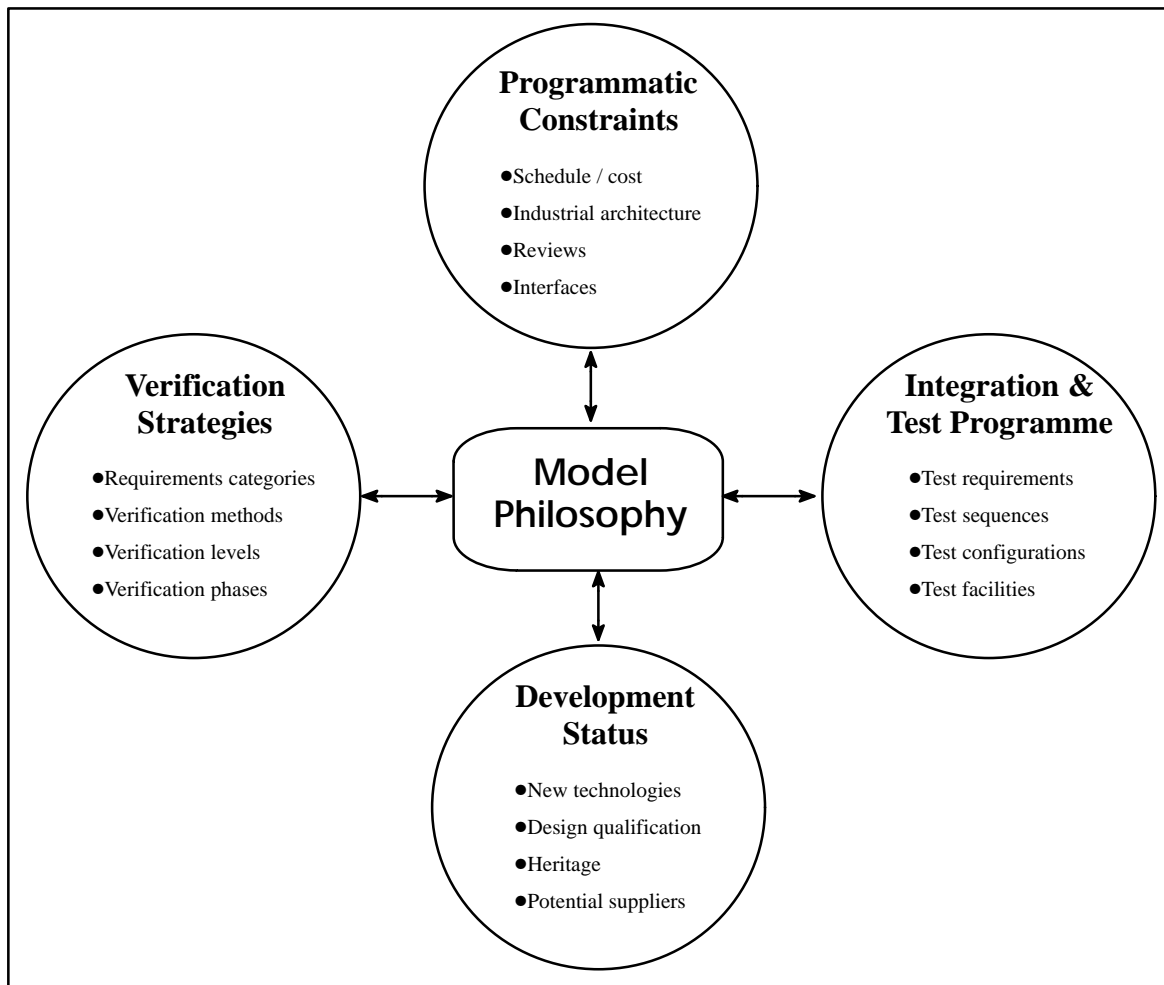

Figure 6: Model Philosophy Definition Process

- b. The model philosophy definition shall combine programmatic constraints, verification strategies, integration and test programme, aspects, availability of verification facilities and development status of the candidate design solution as shown in Figure 6.

Typical model philosophies are prototype, protoflight or a mix of the two called "hybrid philosophy"

4.6.2 Verification strategy

4.6.2.1 Strategy overview

- a. Verification shall be strictly connected to the requirements which represent the start and the end point of the process.
- b. A coherent verification strategy shall be defined for each class of requirement (see clause 4.3.2.1) combining the selected verification methods at the applicable verification levels in the different verification phases in order to ensure consistency between verification activities, and to avoid duplications or holes in the entire verification process.
- c. Appropriate verification matrices shall be generated for each requirement specification.

4.6.2.2 Environmental verification

Verification of the environmental requirements to be applied in qualification and acceptance represents an important subset of the verification process.

Environmental verification strategy shall be based on the most efficient combination of environmental response prediction by models and/or environmental tests.

4.6.2.3 Integration and test

- a. The verification process shall include a proper combination of functional tests during integration and environmental tests.
- b. The selection of the tests to be performed on the defined models at the applicable levels in the different phases shall be in agreement with the chosen verification strategy.
- c. The effectiveness of a specific test shall be evaluated on the basis of statistical data in order to reach the specified level of risk.
- d. The methodologies applied for testing shall be the subject of trade-offs with consideration for state-of-the-art test methods and other available different techniques (e.g. infrared vs solar simulation in thermal balance test).
- e. The test severities (i.e. levels, durations), shall be properly tailored in accordance with requirements, design approach and verification strategy, and shall take into account test conditions (e.g. tolerances).

4.6.2.4 Analysis

- a. Analysis shall be used in the qualification phase very often in combination with test.
- b. Appropriate analysis methodologies used (math. modelling, similarity analysis, simulation, etc.) shall be selected on the basis of technical success and cost effectiveness in line with the applicable verification strategies
- c. Similarity analysis with an identical or similar product shall provide evidence that new applications characteristics and performance are within the limits of the precursor qualified design, and shall define any difference that may dictate complementary verification stages.

4.6.2.5 Review of design/inspection

- a. Review of design shall be used in the qualification phase where review of design concepts and, in general, lower level documentation records is involved.
- b. Inspection shall be used in different phases (including pre-launch, on-orbit, and post-landing) to verify requirements for construction features, document and drawing compliance, workmanship and physical conditions.
- c. Both methods shall be selected in line with the applicable verification strategies.

4.6.2.6 Demonstration

- a. Demonstration shall be used in qualification in combination with test and analysis as appropriate.
- b. Demonstration shall be conducted through observation with or without special test equipment or instrumentation, to verify characteristics such as human factors engineering features, services, access features, transportability, etc.

4.6.3 Verification tools

- a. The verification programme shall be implemented with the support of appropriate verification tools (i.e. ground support equipment, simulators, analytical tools, test facilities, etc.); maximum care shall be devoted to the design and verification of these tools because verification results strictly depend on their quality.
- b. Verification tools shall be standardized to improve commonality and reusability at different levels.

4.6.4 Verification implementation

- a. The verification process shall be implemented through the following main steps:
 - Definition of the overall verification philosophy.
 - Top-down verification requirement generation and associated verification planning.
 - Bottom-up execution of Review of Design/Analysis/Test/Inspection/Demonstration
 - Verification control and reporting.
- b. Proper implementation of the verification process shall be assured through a basic set of documents which typically consists of:
 - Verification matrices associated with specifications.
 - System and lower level Verification Plans.
 - Test requirement specification as a System Support Specification.
 - System and lower level Verification Control Documents (VCD's).
 - Integration and Test Specifications/Procedures.
 - Verification Reports.
- c. The verification process shall be controlled day by day in order to prevent potential problems, reduce risks of cost increase and schedule slip, and give visibility on the verification process to the end-customer.

The use of a verification data base, linked with the requirement data base, is recommended to minimise repetitive work with the possibility of errors, and improve the effectiveness of the overall process.

Requirement traceability is a prerequisite for a nominal verification control activity.

4.7 System engineering interfaces

4.7.1 Management

- a. System Engineering management as defined in clause 4.2.1 shall exchange inputs and outputs with Project Management in order to provide to and receive from the Project Management all necessary technical data for the decision process at System level.
- b. In particular System Engineering shall work in close relationship with Management for matters regarding :
 1. Planning (see clause 4.2.2), with reference to Master Phasing Plan and associated detailed plans to assess, define and control the phasing of activities and monitor milestone events and forecasts
 2. Cost, to supply estimates of activities/resources and monitor accounted activities and trends
 3. Configuration Control, to support finalisation of technical baselines through Configuration Control Boards (CCBs) and properly implement configuration management procedures relevant to product identification, control and accounting.
 4. Procurement (clause 4.2.12), to assure availability of adequate technical data for items to be produced, technical monitoring and control of supplier's activities and products and definition of proper acceptance procedures
 5. Change Management (clause 4.2.13) to coordinate each change proposal, define technical implications, support planning and budgeting of change and commit to finalised released proposal
 6. Risk Management (clause 4.2.11), to allow risk assessments and the risk management policy selection and implementation as in the requirements of ECSS-M-00.

4.7.2 Product assurance

Product Assurance and Systems Engineering activities shall be interfaced in such a way as to ensure reciprocal timely availability of inputs, especially regarding:

- The implementation of the PA requirements in the Technical Specifications, namely Dependability and Safety, EEE Parts, Materials and Processes;
- Verification Requirements;
- Requirement Traceability;
- Assessment of the proposed design solutions, namely :
 - * System Architecture
 - * Functional Architecture
 - * Technology Trade-offs
 - * Materials, Parts and Processes
 - * Safety features
- The conduct of :
 - * Risk assessment studies
 - * Criticality Analyses
 - * Logistic Support Analyses, Maintenance rules (hardware & software)
- Critical Process assessments
- Evaluation of hardware and software verification process/status
- Acceptance Process
 - * Nonconformance treatment

4.7.3 Production

System Engineering shall ensure that all points of interface between System Engineering and Production responsibility are duly supported by communication, cooperation and provision of inputs between the two organisations.

This relates in particular to :

- Incorporation of Design inputs into Manufacturing, AIV and Operations Documents;
- Involvement of Production in evaluations of the design solutions for produceability, testability, cost trade offs;
- Preparation, execution and evaluation of development tests, i.e. tests supporting a prototype design improvement process based on iterative loops of manufacture, test and evaluation when theoretical design work and simulation are not sufficient;
- Development and qualification of manufacturing processes;
- Adjustment and validation of assembly and handling procedures;
- Nonconformance evaluation and disposition (hardware and software)
- Approval by System Engineering of the :
 - * Manufacturing Plan
 - * Assembly, Integration and Test Plan
 - * Test Procedures, including test set-ups
 - * Work Items
 - * Integration Reports
 - * Test Reports
 - * Software test support tools
 - * Automated Test Procedures
- Approval by Production of :
 - * Verification Plan
 - * Test Specifications including set-up
 - * Manufacturing Drawings

4.7.4 Operations & logistics

4.7.4.1 Operations engineering

- a. System Engineering shall regularly support Operations Engineering activity by providing :
 - design feedbacks and implementation policy associated with operations requirements
 - correlation between system performance and operations requirements
 - command and measurement characteristics associated with system equipment
 - engineering (design, interfaces, and configuration) requirements and constraints to be satisfied by the Operations plans and procedures
- b. Conversely, Operations Engineering shall regularly support System Engineering activity by providing :
 - operations scenarios, objectives and requirements for implementation in System design
 - command and measurements list

- operations feedback and implementation policy associated with Engineering requirements and constraints to be satisfied by the Operations plans and procedures

The focus of interaction varies depending on the phase of the project :

Phase A: Operations Engineering to provide operations principles, mission scenarios and functional requirements.

System Engineering to provide preliminary architecture, performances and configuration implementing mission scenarios and functional requirements.

Phase B: Operations Engineering to provide consolidated operations and functional requirements.

System Engineering to provide consolidated architecture, performances and configuration implementing mission scenarios and functional requirements.

Phase C/D: System Engineering to provide requirements and constraints to be implemented in operations plan and procedures.

Operations Engineering to provide feedbacks and implementation policy associated to engineering requirements and constraints

Phase E: Engineering support to Launch Site Operations and Mission Execution.

4.7.4.2 Operations verification

Interface activities in the area of operations verification shall be supported by System Engineering :

- Establishment of operations verification test requirements
- Operations qualification and acceptance, in terms of functional verification, procedures and operational data verification, integrated mission simulation
- Operations verification and testing.

The focus of interaction varies depending on the phase of the project :

Phase B: Establishment of operations verification concepts/general requirements; concept and requirements implementation by System Engineering

Phase C/D: Preparation of Operations verification plan and requirements; integration of plan requirements in the AIV Plan; Operations verification and testing.

4.7.4.3 Operations documentation

Interfaces with Operations documentation shall be supported in :

- a. Users Manual preparation (this is typically under control of Operations but includes sections/data provided by Engineering)
- b. Accommodation Handbooks preparation (this is typically under control of Engineering but includes sections/data provided by Operations)

4.7.4.4 Integrated logistics support

ILS, within the System Engineering process, is a disciplined, unified and iterative approach to the management and technical activities necessary to integrate support considerations into system and equipment design; to develop support requirements that are related to supportability and readiness objectives and to design; to acquire the required support.

System Engineering shall take into account and process the inputs and requirements generated by the Integrated Logistics Support (ILS).

For ILS requirements standard ECSS-M-70 (Integrated Logistic Support) applies.

4.7.4.5 Logistic analyses

- a. Logistic Analyses, by which the logistics support necessary for a new system is identified and evaluated during the Development phase, shall be conducted at System Engineering level.
- b. An essential part shall be represented by the Logistic Support Analysis that operates in :
 - The initial determination and establishment of logistics criteria as an input to System design.
 - The evaluation of various design & support alternatives.
 - The identification and generation of logistics source data for the development and/or provisioning of logistics support elements.
 - Establishment of a Reference Logistics Source Data Database (LSA Record System)

LSA activities are supported and complemented by a set of different analytical methodologies such as:

- Maintenance analysis
- Reliability Centred Maintenance analysis
- Level of Repair analysis
- Logistics Modelling
- Supply Support analyses
- Packaging, Handling, Shipment and Transportation analyses

Specific requirements

The following clauses include System Engineering requirements that are specific to each programme phase and consist of a measurable task or output.

The table is not intended to list all detail tasks/outputs exhaustively nor to be an overconstraining scheme ; the right/responsibility rests with the project to identify and tailor all tasks and outputs responding to the project's specific requirements and constraints.

It represents however a coherent and balanced checklist of key tasks and outputs typical of a nominal project profile available as a primary reference for setting up of project planning, to which it provides consistency and focus.

Programme phases and phase definitions are defined in accordance with Standard ECSS-M-30, as are Reviews.

5.1 System engineering required inputs

For each Phase, the inputs of Table 1 shall be available to allow a System Engineering process to take place.

Table 1: Typical Inputs for System Engineering

Phase	Inputs
0	<ul style="list-style-type: none"> - Mission Concepts - User Needs
A	<ul style="list-style-type: none"> - Phase A System SOW - Mission Requirement Document - Other Complementary Customer Requirements
B	<ul style="list-style-type: none"> - Phase B System SOW - Customer System Requirement Document and Applicable Documents - Phase A Documentation (including as a minimum : System Architectural Report, Mission Analysis Report, System Layout, System Budgets, Dependability and Safety Report, Critical Technology Report, Operations and Logistic Concept, Development and Verification Philosophy) - Phase B System Proposal
C	<ul style="list-style-type: none"> - Phase C/D System and Lower Levels SOW's - Phase B Documentation (including as minimum : System and Subsystem Spec's, Preliminary EQ Spec's, System Design Definition File, Interface Control Documents, Discipline Analysis Reports, Preliminary Verification/ P.A./ Configuration Control/ Operations/ Project Management/ System Engineering Management Plans, System Engineering Drawings, Subsystem Layouts - Phase C/D System and Lower Level Proposals
D	<ul style="list-style-type: none"> - Phase C Documentation (including as a minimum : System and Lower Level Design Definition Files, System and Lower Level Discipline Analysis Reports, System and Lower Level Budgets, System and Lower Level Verification/ P.A./ Conf. Control/ Operations/ Project Management/ System Engineering Management Plans, P.A. Technical Reports, Configuration Items Data Lists, Preliminary Verification Control Documents at System and Lower Levels, and Test, Inspection, Demonstration, and Review of Design Reports).
E/F	<ul style="list-style-type: none"> - Phase E/F SOW - Phase E/F System and Lower Levels Proposals - Phase D Documentation (including as a minimum : System User Manual, Operations and Logistic Analysis Reports, System and Lower Level Acceptance Data Packages, Verification Control Documents, Verification Reports, Flight Operations Procedures, Logistic Support Procedures)

NOTE PA = Product Assurance
SOW = Statement of Work

5.2 System engineering integration & control

Phase	Typical Tasks	Typical Output
O	<ol style="list-style-type: none"> 1. Set up the appropriate S E. organisation to perform this phase 2. Identify precisely mission objectives and environmental constraints 3. Transform mission objectives into system's specification 4. Identify possible System's concepts 5. Identification of possible risks and critical aspects 6. Provide inputs to programmatics (cost, schedule) trade-offs 7. Project development outline 	<p>Requirement trade off vs mission objectives Major risks and proposed risk reduction actions (new R&D, redefine requirements...) Possible candidate Systems Possible organisation for the next phase Programmatic prediction (cost critical path...) Project development outline</p>
A	<ol style="list-style-type: none"> 1. Set up the appropriate S E organisation to perform this phase and draft for future phases 2. Study possible candidate Systems, associated risks and trade studies, involving manufacturing 3. Cost estimation 4. S E capability studies 	<p>Preliminary SEMP Proposed candidate Systems Risk reduction plan Proposed industrial organisation with S E capability Cost objectives and design to cost management plan</p>
B	<ol style="list-style-type: none"> 1. Set up the project S E organisation for phase B, C, and D and out-line E 2. Control the working of the S E organisation 3. Update Life Cycle Cost estimations 4. Review of technical data on resource records 	<p>SEMP Status of risk reduction actions Procurement, manufacturing, test management plan Cost estimation status</p>

Continued.

Phase	Typical Tasks	Typical Output
C/D	<ol style="list-style-type: none"> 1. Complete or update the S E organisation 2. Control its working 3. Control changes at System level 4. Prepare and conduct System Reviews 5. Support make or buy studies 6. Prepare S E support to operation 	<p>Status of risk reduction actions</p> <p>Updated SEMP</p> <p>Manufacturing, Assembly and Test Plan</p> <p>Cost estimation update</p> <p>System Review data packages</p> <p>S E operational support plan</p> <p>Qualified System</p> <p>System technical documentation and Hardware/Software deliverables</p>
E	<ol style="list-style-type: none"> 1. Control the S E support to utilization 2. Design and develop and control the necessary changes 3. Feed back, lessons learnt from anomalies 	<p>Status of qualification</p> <ul style="list-style-type: none"> - anomalies and corrective action - changes - logistic support updates
F	<ol style="list-style-type: none"> 1. Safe orbit parking 2. Shut down procedures 	

NOTE R&D = Research and Development
S E = System Engineering
SEMP = System Engineering Management Plan

5.3 Requirement engineering

Phase	Typical Tasks	Typical Output
O	<ul style="list-style-type: none"> - Make definition of Preliminary programme requirements through the complete life cycle (i.e. mission, operations, performance, support, human factors, quality factors, environment, interfaces, etc.) - Validate preliminary requirements baseline 	<ul style="list-style-type: none"> - Mission Requirement Document
A	<ul style="list-style-type: none"> - Assess end-customer requirements in terms of non-compliance and requirements sensitivity - Define requirement management approach - Provide inputs for the preliminary SEMP 	<ul style="list-style-type: none"> - Requirement Assessment Report - Inputs to preliminary SEMP
B	<ul style="list-style-type: none"> - Plan and organise requirement management activities - Provide inputs for the SEMP - Analyse customer requirements - Generate System and Support Specifications - Allocate requirements to lower levels - Generate preliminary lower assembly level Specifications - Generate Specification Tree - Prepare IRD's and preliminary ICD's (for internal and external Interfaces) - Populate requirement data base with traceability data - Check traceability with respect to customer requirements - Prepare Traceability Report 	<ul style="list-style-type: none"> - System Specification - Preliminary lower level specifications - Specification tree - Interface Requirement Documents - Preliminary Interface Control Documents - Requirement Traceability Report - Requirement data base

Continued.

Phase	Typical Tasks	Typical Output
C	<ul style="list-style-type: none"> - Update System Specifications - Finalise lower level Specifications - Maintain requirements through the req. data base - Start processing requirements changes (Project Directives, Requests for Work, Requests for Deviation) - Perform check of traceability status 	<ul style="list-style-type: none"> - System & lower level Specifications - Interface Requirement Documents - Interface Control Documents - Requirement Traceability Report - Status of req. changes - Requirement data base
D	<ul style="list-style-type: none"> - Maintain requirements through the req. data base - Support maintenance of interfaces through the ICD system - Processing and tracking of Req.'s changes 	<ul style="list-style-type: none"> - Requirements data including changes - Requirement data base
E/F	<ul style="list-style-type: none"> - Make record of requirement feed backs from mission performance 	

NOTE ICD = Interface Control Document
 IRD = Interface Requirement Document
 SEMP = System Engineering Management Plan

5.4 Analysis

Phase	Typical Tasks	Typical Output
0	<ul style="list-style-type: none"> - mission analysis - assessment of operating constraints - preliminary function analysis of the System - preliminary evaluation of system design concepts and critical aspects - organisation costs and schedules first assessment - project development outline assessment - general risk approach analysis 	<p>Inputs to:</p> <ul style="list-style-type: none"> - mission definition - conceptual design reference and trade-offs - preliminary System baseline - technological needs and status - first life cycle product analysis - planning critical path analysis - Dependability and Safety goals
A	<ul style="list-style-type: none"> - analysis of System requirements - System functional trade-offs - technology assessment versus design choices, critical elements analysis - input to Dependability and Safety analysis - preliminary ground segment analysis - margin analysis (mission, product, design), in particular the trade offs between performance levels, cost and schedule targets shall be established 	<p>Inputs to:</p> <ul style="list-style-type: none"> - System baseline and specification - functional requirements - Technology development and procurement plan - Product life cycle definition - SEMP for phase B

Continued.

Phase	Typical Tasks	Typical Output
B	<ul style="list-style-type: none"> - analysis of System designs in terms of performance cost and schedule targets and presentation to management for selection of best compromise - assessment of technologies for selection of early development or critical choices (breadboard) - analysis of manufacturing production and operation costs - reliability and safety assessment - in-orbit environmental aspects assessment and analysis of test requirement - model philosophy trade-offs for defining development plan - analysis of the logistics necessary for fulfilling the mission (ground segment evaluation) - low level requirement analysis - cost assessment - analysis of compatibility of the system interface specifications 	<p>Inputs to:</p> <ul style="list-style-type: none"> - SEMP for phase C/D - Design Justification File (DJF) - risk analysis - cost analysis - System, subsystem and critical equipment Specifications - ground segment Specification - interface specifications - verification requirements - technology trade-offs
C	<ul style="list-style-type: none"> - finalise mission analysis including conditions and cost of operations - analysis of development tests (breadboard, technologies, margins) - analysis of operations and cost - perform periodic assessment of the verification analysis of verification tools - assessment of the requirement specification - input to complete Dependability and Safety analysis 	<p>Inputs to:</p> <ul style="list-style-type: none"> - equipment Specification - ICD's - technology trade offs - test analysis reports - Dependability and Safety analysis - Mission analysis

Continued.

Phase	Typical Tasks	Typical Output
D	<ul style="list-style-type: none"> - analysis of the ground qualification process - perform periodic assessment of the verification programme - analysis of verification acceptance - analysis report of qualification and acceptance - analysis of functional and operational margins - analysis of in-orbit failure recovery for operational handbook 	<ul style="list-style-type: none"> - Qualification and Acceptance Analysis Reports - functional and operational margins analysis report
E/F	<ul style="list-style-type: none"> - analysis of in-flight qualification with reference to mission and operational requirements - analysis of in-orbit flight data - analysis of ground segment performance - support the failure investigation 	<ul style="list-style-type: none"> - in-orbit performance analysis report - lessons learned

NOTE ICD = Interface Control Document
SEMP = System Engineering Management Plan
VCD = Verification Control Document

5.5 Design and configuration

Phase	Typical Tasks	Typical Output
O	<ul style="list-style-type: none"> - Establishment of System design concepts 	<ul style="list-style-type: none"> - Conceptual System design
A	<ul style="list-style-type: none"> - Establishment of System design baseline - Technology assessment 	<ul style="list-style-type: none"> - System Design Baseline - Technology Plan
B	<ul style="list-style-type: none"> - Identify Interfaces of Assemblies - Generate Budgets - Select standard components - Examine technologies - Material selection, Make or Buy - Complete preliminary drawings for each subsystem 	<ul style="list-style-type: none"> - Preliminary System and Subsystem Drawings - Interface Control Document - Budgets - For Critical S/S : Simulation or Breadboard Models - For Critical Technologies : feasibility
C	<ul style="list-style-type: none"> - Balancing of the design taking into account cost, schedule, performance and risk for the life cycle - Finalisation of the physical architecture as an integrated detailed design for people, products and processes - Check design compatibility with external Interfaces 	<ul style="list-style-type: none"> - Detailed Design for the Start of Manufacture of Flight Hardware - Technological Readiness - Process Documentation, Material Specification, Tools and Handling Procedures verified
D	<ul style="list-style-type: none"> - Updating of flight standard design - Maintenance of documentation 	<ul style="list-style-type: none"> - Completed Flight Standard Design Baseline. - Completed Process Documentation, Handling Procedures, Material Specification etc.. - As-Built Status and Items

5.6 Verification

Phase	Typical Tasks	Typical Output
0	<ul style="list-style-type: none"> - Support to definition of technological aspects and development concept, including verifiability 	<ul style="list-style-type: none"> - Input to development documentation
A	<ul style="list-style-type: none"> - Support requirement assessment - Define verification methods and associated verification strategies - Define model philosophy - Prepare Hardware Matrix including qualification status - Generate a verification philosophy (preliminary plan) - Provide inputs to development philosophy for the preliminary SEMP - Coordinate possible lower level contributions - Support the generation of phase B planning and cost estimate 	<ul style="list-style-type: none"> - Input to Requirement Assessment Report - Input to preliminary S E Management Plan - Preliminary Verification Plan - Input to Phase B planning & cost estimate
B	<ul style="list-style-type: none"> - Support analysis of customer requirements - Support generation of System Specification - Prepare system verification matrices - Prepare Test Requirement Specification - Support requirement allocation & traceability - Support generation of preliminary lower level Specifications and relevant verification matrices - Prepare system Verification Plan and Verification Control Documents (VCD) - Coordinate the preparation of preliminary lower level Verification Plans and VCD's - Initiate the set-up of verification data base - Provide input for the SEMP - Support the preparation of programmatic documentation - Support the generation of phase C/D planning and cost estimate 	<ul style="list-style-type: none"> - Input to System and lower level Specifications in particular Verification Matrices) - Test Req. Specification - System Verification Plan - System VCD - Verification data base - Preliminary lower level Verification Plans & VCD's - Input to System SEMP - Input to programmatic documentation - Input to phase C/D planning and cost

continued

Phase	Typical Tasks	Typical Output
<p>C</p>	<ul style="list-style-type: none"> - Support updating of System and lower level Specifications - Update Test Requirement Specifications - Finalise System and lower level Verification plans - Update System and lower level VCD's - Perform periodic assessment of the verification programme (Verification Control Board) - Maintain Verification Data Base - Monitor lower level qualification verification activities - Support System and lower level Reviews (PDR, Test Readiness Review, TRB) - Review and approve lower level verification documentation - Generate first System Int. & Test Specifications and Procedures - Coordinate and monitor system verification activities - Perform System and lower level Int. & Test on development model(s) - Start System and lower level Int. & Test on qualification model(s) - Monitor definition and procurement of verification tools 	<ul style="list-style-type: none"> - Input to final System and lower level Spec's - Final System and lower level Verification Plans - System and lower level Int. & Test Specifications and Procedures for Development/Qualification models - Verification data base - System and lower level Development Models - System and lower level Qualification Models - Verification tools

continued

Phase	Typical Tasks	Typical Output
D	<ul style="list-style-type: none"> - Update and complete system and lower level VCD's - Perform periodic assessment of the verification programme (VCB) - Maintain verification data base - Monitor lower level verification acceptance activities - Support system and lower level Reviews (Qualification Review, Final Acceptance Review) - Review and approve lower level verification documentation - Coordinate and monitor system verification activities - Complete system and lower level Int. & Test Specifications/Procedures - Complete System and lower level qualification and acceptance activities - Generate system and lower level Verification Reports for qualification and acceptance - Provide input to phase E/F documentation - Support the generation of phase E/F planning and cost estimate - Monitor procurement of verification models 	<ul style="list-style-type: none"> - System and lower level VCD's - System and lower level Verification Reports - System and lower level Int. & Test Specification and Procedure for qualification and flight models - Verification data base - Input to phase E/F documentation - Input to phase E/F planning and cost estimate - System and lower level flight models - Verification tools
E/F	<ul style="list-style-type: none"> - Support mission operations and disposal activities for verification aspects - Maintain verification data base - Monitor system verification during pre-launch, on-orbit, post-landing phases - Generate System verification reports for above phases - Update System VCD - Support System Reviews (Launch Readiness Review, Commissioning Review, End of Mission) - Coordinate possible verification support from lower levels - Support the assessment of operations performances and associated failure investigations 	<ul style="list-style-type: none"> - Verification Reports - VCD - Input to operation assessment - Verification data base

NOTE PDR = Preliminary Design Review
 S E = System Engineering
 SEMP = System Engineering Management Plan
 TRB = Test Review Board
 VCB = Verification Control Board
 VCD = Verification Control Document

(This page is intentionally left blank)

Annex A (informative)

DRD: system engineering management plan

Purpose :

Defines and describes approach to and details of System Engineering activities to be performed by the Contractor and his lower tier contractors

Delivery at :

Proposal, SRR, PDR

Summary of Contents/Preparation Information :

The contractor Plan shall comply with Standard ECSS-E-10 "System Engineering of Space Programmes".

The Plan shall cover all Engineering activities to be performed within the applicable contractual time and responsibility boundaries.

It shall highlight key engineering methods and tools to be applied and describe interfaces to external activities.

This Plan shall also reference and make use of the lower tier Engineering Management Plans and provide a coherent and consistent planning document for the entire Contractor programme.

The Plan Contents List shall be tailored to the specific needs of a Programme based on the attached model.

TYPICAL CONTENTS LIST

1	INTRODUCTION
1.1	Scope
1.2	Applicability
2	APPLICABLE DOCUMENTS
3	PROGRAMME OVERVIEW
3.1	Objectives and Constraints
3.2	Project Phases and Reviews
3.3	Technical Organisation and Responsibility Allocation
3.3.1	System
3.3.2	Subsystems
3.3.3	Assemblies and Units
3.3.4	Software Products

3.3.5	Relations to Subsystem, Assembly, Unit Software and Services Contractors
3.3.6	Purchaser and Contractor Relations
3.4	Master Schedule
4	APPROACHES & TECHNIQUES
4.1	System Engineering Integration & Control
4.1.1	System Engineering Management
4.1.2	Engineering Discipline Integration
4.1.3	Engineering Data Base
4.1.4	Interface Management
4.1.5	Budget and Margin Philosophy
4.1.6	Technology
4.1.7	Post Delivery Support
4.1.8	Cost Effectiveness
4.1.9	Risk Management
4.1.10	Procurement Support approach
4.1.11	Engineering Capability Assessment
4.2	Requirement Engineering
4.2.1	Specifications
4.2.2	Requirement Process
4.2.3	Requirement Management
4.3	Analyses
4.3.1	System Analyses
4.3.2	Functional Analysis & Allocation
4.3.3	Analysis Tools & Models
4.4	Design & Configuration
4.4.1	Design Process
4.4.2	Architecture
4.4.3	Configuration
4.4.4	Design Tools
4.5	Verification
4.5.1	Verification Process
4.5.2	Verification Strategy
4.5.3	Verification Tools
4.5.4	Verification Implementation
4.6	System Engineering Interfaces
4.6.1	Management <ul style="list-style-type: none">- Planning- Documentation & Data Exchange- Procurement- Change Management
4.6.2	Product Assurance <ul style="list-style-type: none">- Dependability- Safety
4.6.3	Production
4.6.4	Operations & Logistics

-
- 5 DISCIPLINE SPECIFICS**
- 5.1 System Engineering Integration Level
- Payload
 - Human Factor Engineering
 - Environment
 - Serviceability
 - Microgravity Control
 - etc.
- 5.2 Mechanical
- Structures
 - Mechanisms
 - Fracture Control
 - Mechanical Ground Support Equipment
 - etc.
- 5.3 Propulsion & Reaction Control System
- 5.4 Thermal-Environmental
- Thermal Control
 - Environmental Control & Life Support
 - Contamination Control
 - Fluid Ground Support Equipment
 - etc.
- 5.5 Avionics
- Electrical Power Generation, Distribution & Storage
 - Electro-Magnetic Compatibility
 - Data Management
 - Optics
 - Communications
 - Harness
 - Electric Ground Support Equipment
 - etc.
- 5.6 Controls
- AOCS
 - Robotics
 - Docking/Berthing
 - etc.
- 5.7 Software
- Flight Software
 - Ground Software
 - Simulation
 - etc.
- 6 CRITICAL TECHNOLOGIES**

(This page is intentionally left blank)

Annex B (informative)

Organisation of system engineering Level 3 standards

System Engineering level 3 standards cover specific aspects of System Engineering of either a procedural or a technical nature, and are believed to result in more economical or more compliant products if implemented with an optimum, standardized approach.

The plan of these standards is therefore not meant to cover, even in the long term, the total scope of System Engineering activities to a greater level of detail than ECSS-E-10, but only those aspects where detail standardization is economical and not overconstraining.

Except for the overall System Engineering process, Table B-1 groups standards per System Engineering function because a path per function is recommended for the screening of technical implementation requirements in a programme's organisation phase.

Table B-1: Level 3 System Engineering Standards

Number	Title	Scope
ECSS-E-10-01	System Engineering Process	Theory of System Engineering (generic, not limited to space applications) : <ul style="list-style-type: none"> - System Engineering building blocks - Dynamics of the typical process "engine"
System Engineering Integration and Control		
ECSS-E-10-101	Standard practice for interface management	Guideline to the organisation of interface management : <ul style="list-style-type: none"> - interface requirement documents - interface control documents - formal tools and mechanisms
ECSS-E-10-102	System Engineering capability assessment	System Engineering capability, maturity measurement model, model description
ECSS-E-10-103	Engineering data base requirements	Self-explanatory

Continued

Table B-1: Level 3 System Engineering Standards (continued)

Number	Title	Scope
ECSS-E-10-104	Environmental engineering guidelines	Guidelines for a correct interdisciplinary approach to environmental requirement assembly and design solution
ECSS-E-10-105	Natural and induced environments in space	Objective models for each type of space environment, e.g. radiation, sun, debris, atmosphere, etc.
ECSS-E-10-106	Human factors for space systems	Statistics of human measures and performance for all activities and environments associated with space
ECSS-E-10-107	Human system integration	Guidelines for the implementation of design selections respectful of human factors, in any item associated with physical human interface
ECSS-E-10-108	Human-computer interface for space systems	Self-explanatory
ECSS-E-10-109	Design to cost	Definitions and methodologies to derive technical requirements against limiting and firm cost constraints
Requirements		
ECSS-E-10-201	Specification practice	Guidelines to structure technical specifications of all levels and spell out requirement
ECSS-E-10-202	Requirement traceability principles	Requirement traceability principles mechanics and tool requirements
Analysis		
ECSS-E-10-301	Functional analysis	Principles and methodologies of the functional analysis
ECSS-E-10-302	Mathematical Models	System level requirements of mathematical models developed for system analyses
Design		
ECSS-E-10-401	Coordinate system and reference level for space vehicles	Self-explanatory
ECSS-E-10-402	Drawing system	Requirements for the selection and setting up of a drawing system
ECSS-E-10-403	Design requirements for CAE interfaces	Self-explanatory
ECSS-E-10-404	Guide to the software architectural design	Guidelines to develop a project's software architecture as part of an integrated system approach

Continued

Table B-1: Level 3 System Engineering Standards (continued)

Number	Title	Scope
Verification		
ECSS-E-10-501	Verification guidelines for manned and unmanned spacecraft	Self-explanatory
ECSS-E-10-502	Test requirements for space equipment	Self-explanatory
ECSS-E-10-503	Analysis, review of design and inspection requirements for space equipment	Self-explanatory
ECSS-E-10-504	Requirements for verification tools, Ground Support Equipment and facilities	Self-explanatory
ECSS-E-10-505	Requirements for assembly and integration	Self-explanatory
ECSS-E-10-506	Environmental test methods	Self-explanatory

(This page is intentionally left blank)

Annex C (informative)

System engineering documentation definitions

Analysis procedure

This document lists all the requirements to be verified by analysis, grouping them in categories detailing the Verification Plan activity sheets, with planning of the execution and a definition of the associated procedures.

Analysis report

This document describes, for each analysis, assumptions, utilised methods, software and results and contains evidence to show that the relevant requirements are satisfied.

Drawing Tree

A drawing tree reflect the drawings associated with the elements.

Hardware Matrix

The matrix identifying for each equipment the related qualification status and the required models.

Integration & Test Procedure

This document provides detailed step-by-step instructions to the Int. & Test teams for conducting the int. and test activities in agreement with the Int. & Test Specification requirements.

Integration & Test Specification

This document is prepared for each major integration and test activity described in the Verification Plan task sheets with the aim of giving detailed integration and test requirements.

Interface Control Document (ICD)

A document which contains the current baseline of detailed system internal and external interfaces, with reference to the IRD requirements.

It controls the interface requirement evolution and reflects in principle the detailed status of the interested interfaces against which each interface requirement will be verified.

Interface Requirement Document (IRD)

Type of specification dedicated to internal and external system interface requirements.

It describes of essential functional, performance, and physical requirements and constraints at a common boundary between two or more functions or physical items.

It drives the interface management activities.

Specification Tree

The hierarchical structure of all the specifications applicable to a system and its constituents in the transition from customer needs to the complete set of products and services that satisfy those needs.

Specification Preparation and Format Instructions

Self-explanatory

Test Requirement Specification

This document is a system support specification applicable to all verification levels containing the general test requirements in terms of type of test, sequences, margins, durations, tolerances, screening policy and methodology.

Verification Control Document (VCD)

This document lists all the requirements to be verified with the selected methods in the applicable phases at the defined levels and traces during the phase C/D, how and when each requirement is planned to be verified and is actually verified. The VCD may be an output from the Verification Data Base.

Verification Matrix

Matrix associating to each requirement the selected verification methods for the different verification levels in the applicable verification phases.

Verification Plan

This document is the master plan for the project verification process and demonstrates how the requirements will be verified by a coherent implementation approach. The plan will cover the environmental test aspects.

Verification Report

This document gives evidence that the verification activities have been properly performed describing results and associated evaluation.

It could be either test, analysis, Review Of Design, inspection report or a combination of them in the case where more than one of the methods is utilised to verify a requirement or a specific set of requirements.