

ECSS E 20 series, tutorial

F. Tonicello

TEC-E

ESA-ESTEC

rev1.6

COPYRIGHT NOTICE:

By using the ECSS Training material, developed by ESA, you agree to the following conditions:

1. The training shall take place at your premises and shall be addressed to your staff (internal participants);
2. In case of a training to be given to external participants, the prior ESA written authorisation shall be requested;
3. The ESA Copyright shall always be mentioned on all Training Material used for the purpose of the training and participants shall acknowledge the ESA ownership on such a Copyright;
4. The Training material shall not be used to generate any revenues (i.e. the training and Training Material shall be "free of charge" excl. any expenses for the training organisation);
5. Only non-editable PDF files of the Training Material can be distributed to the participants (nor power point presentations);
6. Any deficiency identified in the Training Material shall be reported to the ECSS secretariat;
7. If the Training Material is modified or translated, the ESA Copyright on such edited Training Material shall be clearly mentioned. A copy of the edited Training Material shall be delivered to ESA for information.
8. You shall always hold harmless, indemnify and keep ESA indemnified against any and all costs, damages and expenses incurred by ESA or for which ESA may become liable, with respect to any claim by third parties related to the use of the Training Material.

SCOPE

- Understanding of key requirements
- Develop a better familiarity with ECSS E20 series
- Better capability to interface with ESA on electrical matters
- Better capability to evaluate deviations and waivers with proper knowledge of underlying rationale

Coverage

- ECSS-E-ST-20C,
Electrical and electronic,
in this presentation called “STD”
- E-ST-20-20C (E-HB-20-20A),
Electrical design and interface
requirements for power supply
- ECSS-E-ST-20-06C,
Spacecraft Charging
- ECSS-E-ST-20-07C,
Electromagnetic Compatibility
- ECSS E-ST-20-08C Rev. 1,
Photovoltaic Assemblies and Components
- ECSS E-ST-20-01A (Multipaction design and
test) is not covered, dealing it with RF issues

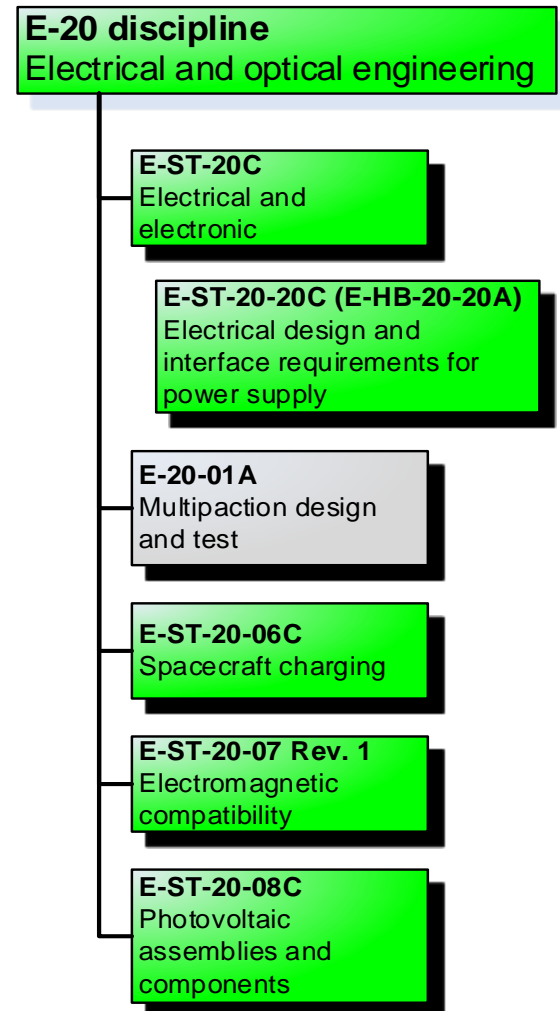

ECSS-E-ST-20C, Electrical and electronic

TEC-EP

ESA-ESTEC
rev1.1

1. Brief history

From the PSS-02-10 to the ECSS-E -ST-20C

1992: Power Standard and Rationale for the Power Standard
ESA PSS-02-10 Vol 1 and 2

1999: ECSS Standard, Electrical and Electronic
ECSS-E-20A

2008: ECSS Standard, Electrical and Electronic
ECSS-E-ST-20C

General remarks:

-> Strong heritage from Power domain

-> Update every 7/9 years so far

-> These documents include a large number of lessons learnt of previous projects

1. Electronics and power subsystem, key principles
 - a. Electronics for space
 - b. Space power subsystem
2. Key categories of requirements
 - a. Reliability
 - b. Functionality
 - c. Performance
3. Why/when/how to use the STD
4. Presentation of the main chapters
5. Key STD Definitions
6. Key STD requirements
7. Conclusions

- 1. Electronics and power subsystem, key principles**
 - a. Electronics for space**
 - b. Space power subsystem**
2. Key categories of requirements
 - a. Reliability
 - b. Functionality
 - c. Performance
3. Why/when/how to use the STD
4. Presentation of the main chapters
5. Key STD Definitions
6. Key STD requirements
7. Conclusions

1. Electronics for space
 - a. Peculiarities! = > comparison with terrestrial electronics
 - b. Additional peculiarity for power subsystem

ECSS E ST 20C, Electronics for space and for terrestrial purposes



	Space application	Terrestrial application
Radiation	<p>Total Dose Irradiation and Single Event Effects are key drivers.</p> <p>Radiation hardened or at least radiation tolerant components shall be used.</p>	<p>Total dose irradiation is negligible and Single Event Effects are rare due to the screen by the Earth atmosphere</p>
Thermal dissipation	<p>Conduction/radiation only.</p> <p>A component running at 40°C in a terrestrial environment might produce case temperatures exceeding 200°C in vacuum.</p>	<p>Convection / forced air is commonly used to keep electronic components under acceptable temperatures</p>
Lifetime	<p>Typically, very extended (up to 18 years operation in telecom satellites)</p>	<p>Typically limited (few years design goal)</p>
Reliability/failure tolerance	<p>Generally, no repair capability during lifetime</p> <p>Important de-rating needs (ECSS-Q-30-11C)</p>	<p>Generally repair is easily feasible: change parts, components</p>
Main design drivers for power electronics	<p>Design mainly driven by reliability and performances (efficiency, mass, volume)</p>	<p>Main driver are usually cost and compactness</p>

Power Generation

- Provide the power required by the spacecraft from launch until the mission completion
- Usually a solar array for near sun satellite applications, sometimes a Radio-Isotope Thermoelectric generator (RTG) for spacecrafts that have to operate at great distances from the sun

Energy Storage

- Store energy during sunlight
- Ensure a continuous source of electrical power during eclipses
- Complement the power source as needed (e.g. peak power demands, manoeuvres)

Power Conditioning

- Provide autonomous control of the power generation and energy storage
- Condition the power bus to a defined voltage range
- Provide command and telemetry capability for health check and control

Power Distribution

- Distribute the power to all the spacecraft loads
- Provide load switching capabilities
- Protect the power lines to avoid failure propagation between loads and EPS

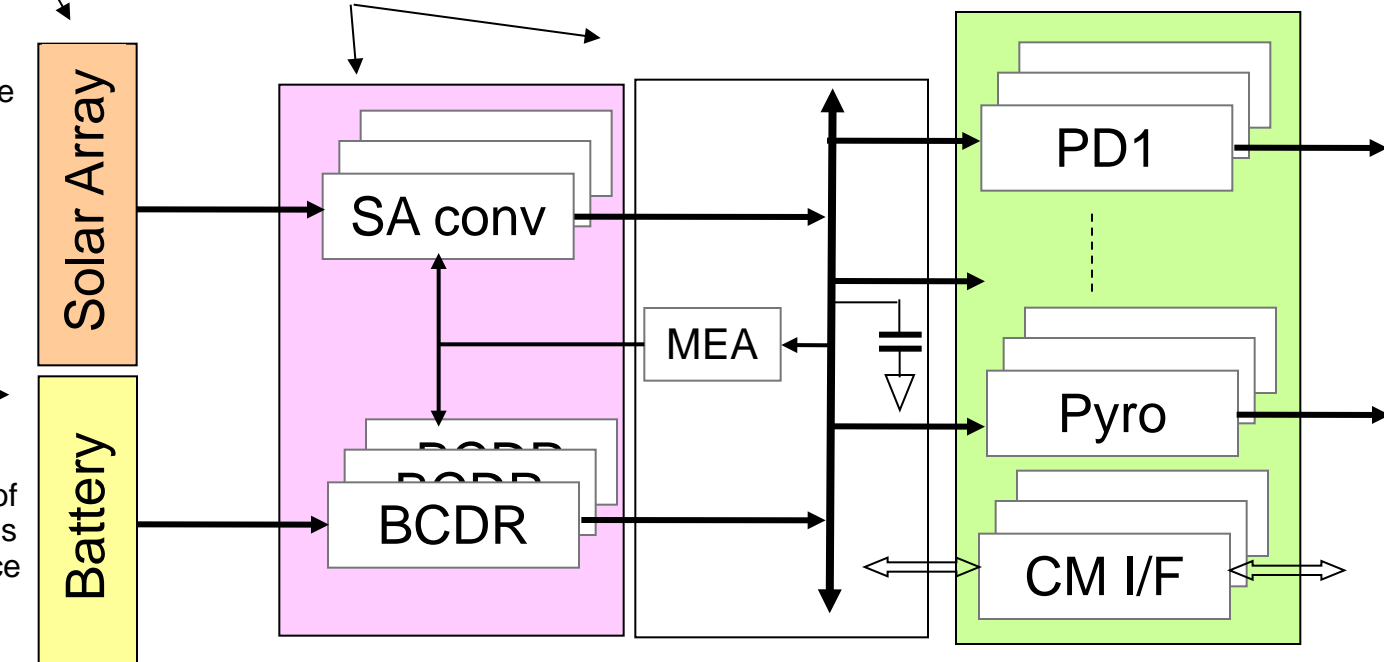

ECSS E ST 20C, Conventional Space Power Generation and Storage Technologies



Technology	Conversion Technique	Maturity	Typical Application
Photovoltaic Conversion	Photovoltaic Solar Arrays	++	Manned earth orbiting platforms. Earth orbiting spacecraft Planetary missions anywhere between Mercury and Jupiter orbits
Electrochemical	Primary batteries Secondary batteries Fuel Cells	++ ++ +	Manned earth orbiting platforms. Earth orbiting spacecraft Planetary missions anywhere between Mercury and Jupiter orbits
Mechanical	Flywheel	-	
Nuclear	Radioisotope thermoelectric generators (US) Reactors (URSS)	+ (US/Russia) -	Outer planet/Deep Space exploration Manned moon and planetary exploration and rovers

ECSS E ST 20C, Solar array (1/5) - Space vs terrestrial solar cell

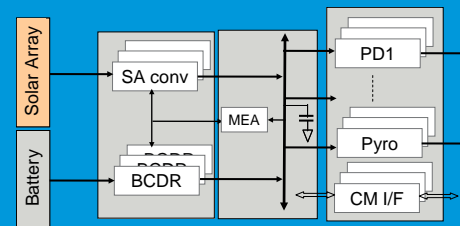

Space application	Terrestrial application
<p>Sun spectrum is unfiltered (AM0)</p> <p>Electron and proton radiation cause degradation (also micrometeorites, man-made debris, UV, failure rates of components and electrical connections)</p> <p>Mass is important since launch costs are high (around 15-20k euros per kilo)</p> <p>Solar generator area is important. In particular a high efficiency cell (MJ)</p> <ul style="list-style-type: none"> - Require less panels/mechanism - Less attitude control effort <p>Note: if cell efficiency is less than ~12%, even a zero cost solar cell is not a commercially viable solution Only high efficiency multi-junction cells are cost effective at subsystem and system level</p>	<p>Sun spectrum is filtered by the earth's atmosphere and UV is attenuated by atmosphere and optics</p> <p>No particle radiation</p> <p>Mass is not an issue</p> <p>Many material technologies are potentially cost effective</p> <ul style="list-style-type: none"> - cheap, low efficiency flat plate - GaAs based in tracking concentrator systems

ECSS E ST 20C, Solar array (2/5) - Characteristic of a solar cell

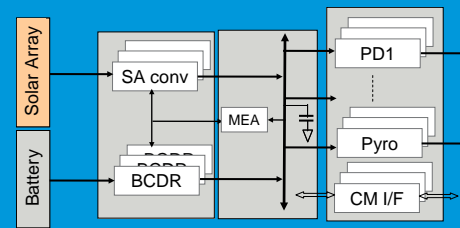

Convention:
I-V curves are mirrored
at the x-axis

Power curve:

$$P = I \cdot V$$

I_{SC} : short circuit current

V_{OC} : open circuit voltage

P_{MPP} : maximum power
point

FF: Fill factor

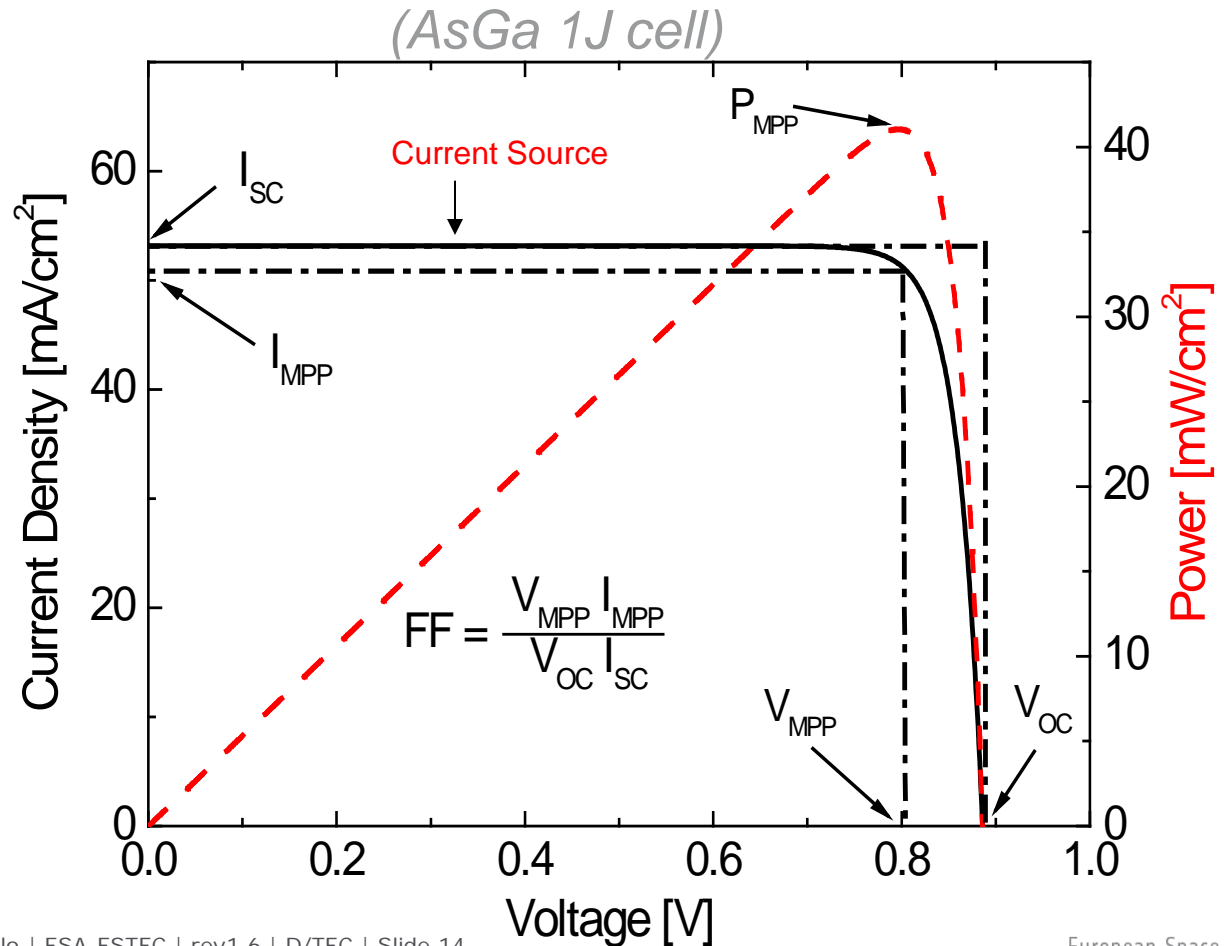

ECSS E ST 20C, Solar array (3/5) - What affects the I-V Curve?

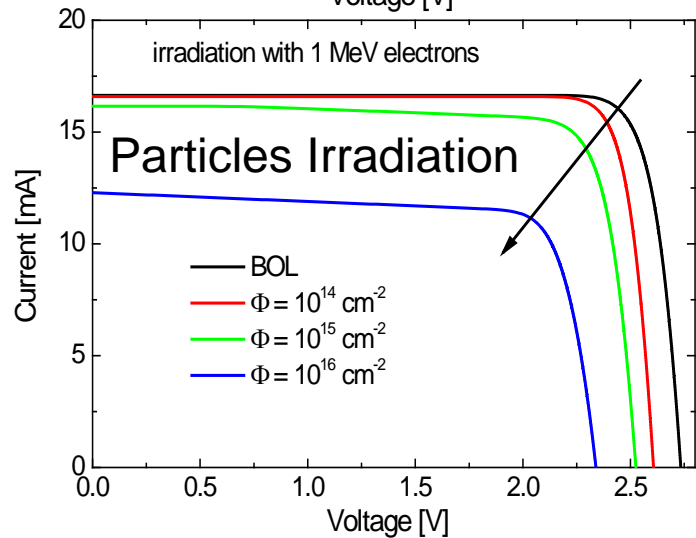
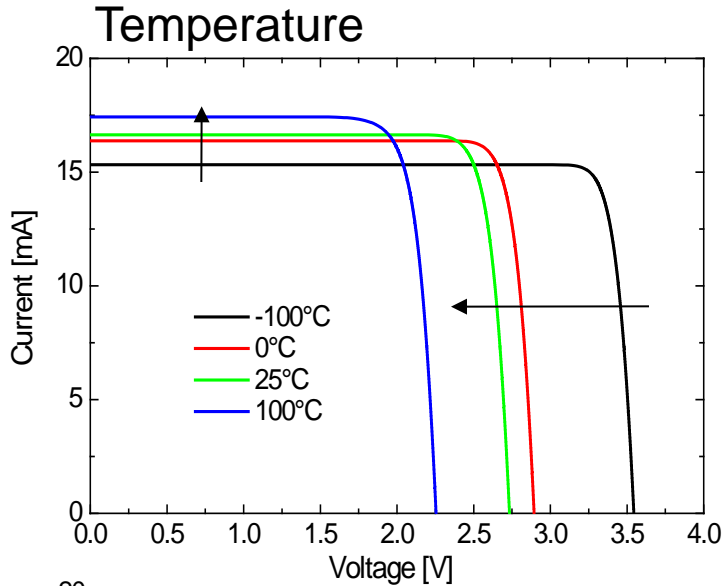
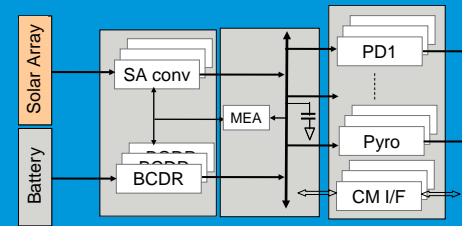

PV Technology

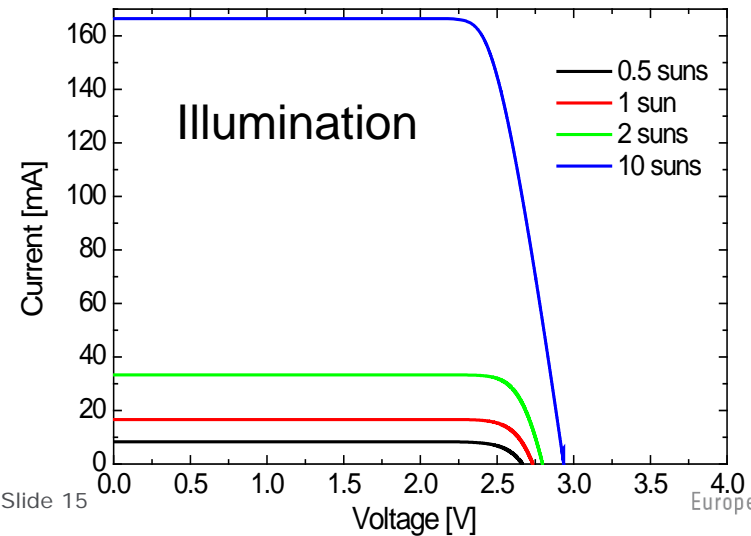
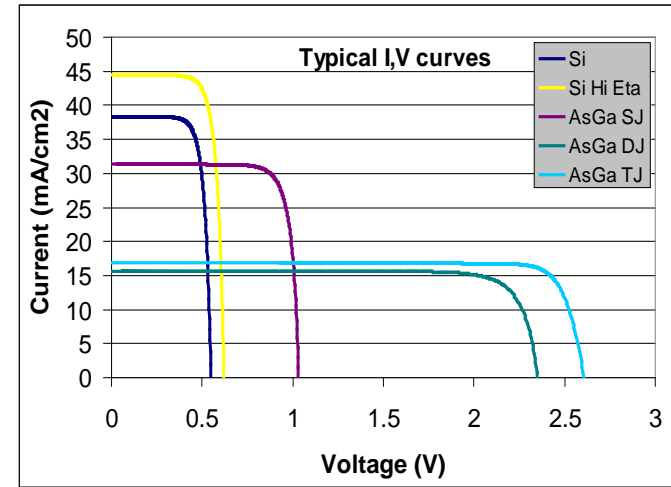

ECSS E ST 20C, Solar array (4/5) - State-of-the-art 3J solar cell

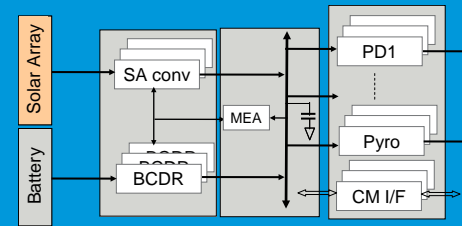

Material: GaInP/GaInAs/Ge
2 cells on 4" wafer
Dimensions: 4 x 8 cm² with
cropped corners (30.18 cm²)

Thickness: 150 ± 20 μm

Area: 30.18 cm²

av. weight: ≤ 86 mg/cm²

av. efficiency (BOL): 29.5 %

av. efficiency (EOL at
1E15e/cm²-1MeV eq.): 26.5 %

⇒ high remaining factor of 0.89
(after 15 years in GEO)

3G30% by Azur Space



29.5 % · 1367 W/m² · 30.18 cm² ≈ **1.2 W**
Assembly:

- cells assembled in strings connected
- strings connected in parallel (=section)
- failures contained in one string (use of diodes)

Efficiency evolution (fully qualified product)

30% in 2014

32% in 2015

35% in 2016-2017

European Space Agency

ECSS E ST 20C, Solar array (5/5) - Typical numbers

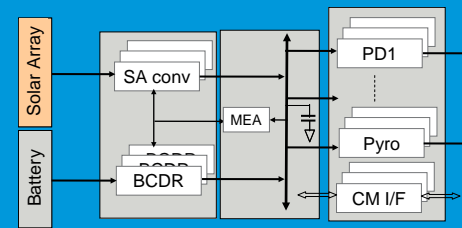

	distance AU	illumination W/m2	temperature °C
mercury	0.387099	9123	238
venus	0.723	2615	101
earth	1	1367	45
mars	1.52	592	-15
jupiter	5.2	51	-134
saturn	9.54	15	-170
uranus	19.18	4	-200
neptune	30.07	2	-215
pluto	39.44	1	-222

1. Temperatures shown are simple approximation for a GaAs based solar array wing perpendicular to the sun – not intended to be very accurate
2. NB combination of intensity + temperature + radiation is important !!
3. beyond Jupiter => too dark for solar power !

ECSS E ST 20C, (rechargeable) batteries (1/3)

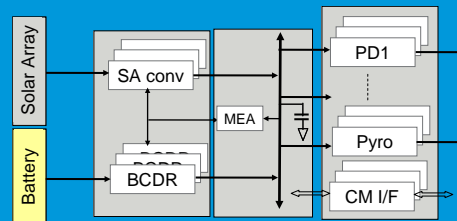

European Li-Ion Battery Suppliers

2 suppliers / 2 approaches

SAFT (F): *Developing specific cells for Space Applications*

- 40 and 50 Ah (140 and 180 Wh) Li ion cells qualified
- High Rate Cells for Vega (VL8P cells)
- 5 Ah Prismatic cell MP176065 qualified for LEO missions and Launcher (Vega)
- VES16 cells qualified (16 Wh), based on same chemistry as 40Ah cell, and using a simplified balancing system (SBS) on each individual cell.



10S8P
VES16 –
1300 Wh
at C/3
(20°C)

ABSL – Energysys (UK) : *use commercial small cells for Space missions*

- Pioneered small lithium-ion cell battery approach using 1.5 Ah SONY 18650HC commercial cells. Qualified for numerous science, earth observation and microsattellites. Cell is now obsolete, replaced by SONY 18650HCM and later by ABSL18650NL (from other from other battery cells manufacturers)
- High Rate Cells for Launchers (ABSL18650 HR)

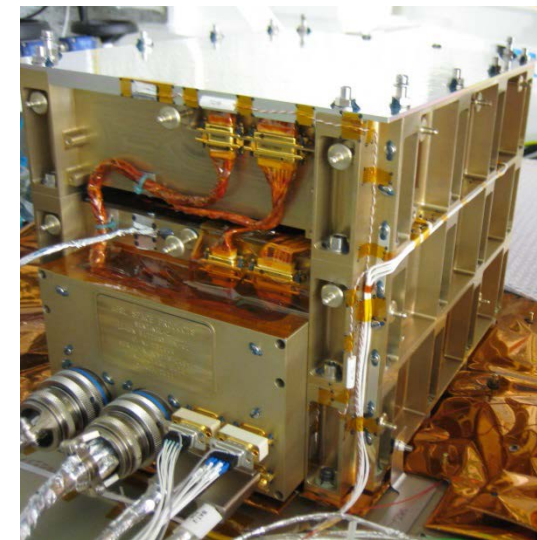

Sentinel 2, ABSL 18650HC
Flight Model

European Space Agency

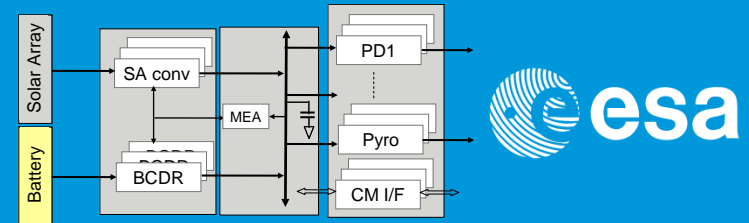

Cells Assembly

Cells mounted in series to build up voltage output.
Cells/strings mounted in parallel to fit the energy/capacity requirement.

Redundancy Approach: A cell might fail open or short

Small cells approach:

- Individual cell overcurrent/overcharge protections
- Strings in parallel without interconnections.
- Cells matched & battery charge management done at battery level
- One additional spare string for tolerance to the failure of any cell
- Cell individual balancing circuitry if necessary (e.g VES16)

Large cells approach:

- Cells in parallel interconnected
- Individual charge management/balancing capability for each group of cells in parallel
- By-pass protection for each group of parallel cells
- One additional group of cells in series for tolerance to the failure of any cell

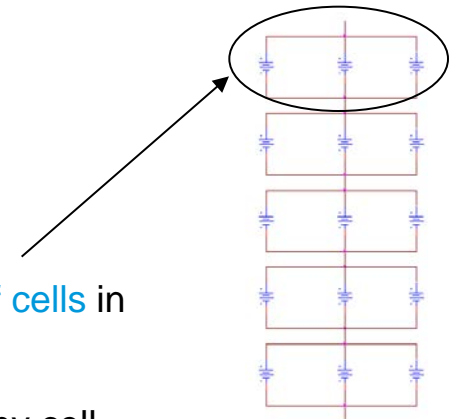
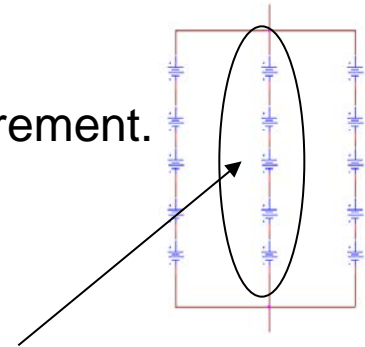

ECSS E ST 20C, (rechargeable) batteries (3/3)

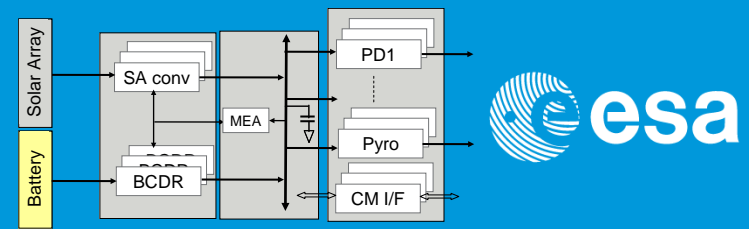

Li-Ion Battery Charge technique & performance degradation

- Charge technique:
 - Limit Charge Rate: $C/4 \Leftrightarrow C/2$
 - Followed by Voltage Tapering at Veoc (4.05-4.1V/cell)
- Limiting discharge depending on mission calendar and cycling requirements:
 - Low number of charge/discharge cycles => Higher DoD allowed (GEO typ. max 70%)
 - High number of charge/discharge cycles => Lower DoD allowed (LEO typ. max 30%)

Cycling Degradation

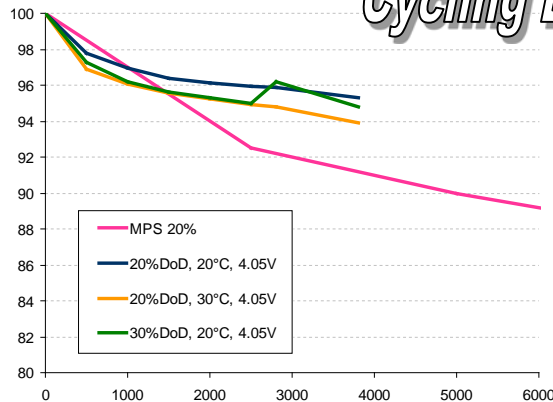

Retained capacity upon LEO continuous cycling of SAFT VES16 (compared to SAFT MPS176065 cell)

Ageing Degradation

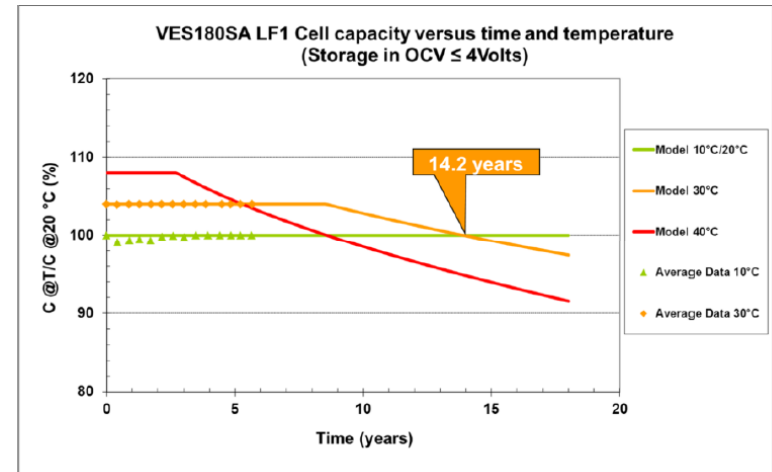

ECSS E ST 20C, Electrical Power Sub-System, peculiarities

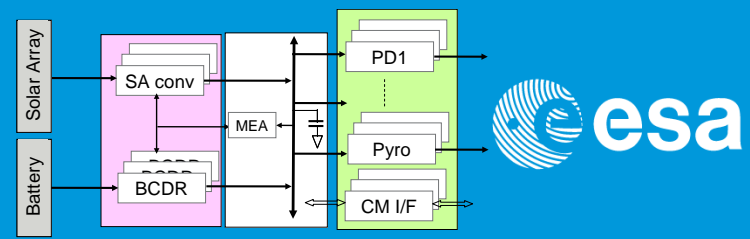

Failure tolerance

- Once launched, (usually) **no repair** is possible
- The rule:
"No single component failure shall result in a significant loss of spacecraft operation."
has a very important consequence for the **redundancy**, **reliability** and **performance** aspects of the power-system design.
- A controlled reduction of power capability might be allowed after a Single Point Failure (e.g. loss of one SA section) or a full **Single Point Failure Free (SPFF)** approach can be required.
 - for manned missions this requirement is enlarged such that double failures shall be tolerated without impacting the safety of astronauts.
- **Modular concepts** are introduced (hot or cold redundancy schemes)
 - Separation of critical sub-circuits (both mechanically and electrically)
 - Redundant connectors on critical lines
- Additional features incorporated in each module to **avoid failure propagation** due to short circuits, over current, over voltage conditions.

Autonomy

- The power system shall **not** be controlled by an "intelligence" whose circuits are supplied by the power system itself

ECSS E ST 20C, Electrical Power Sub-System, conditioning part, typical topologies

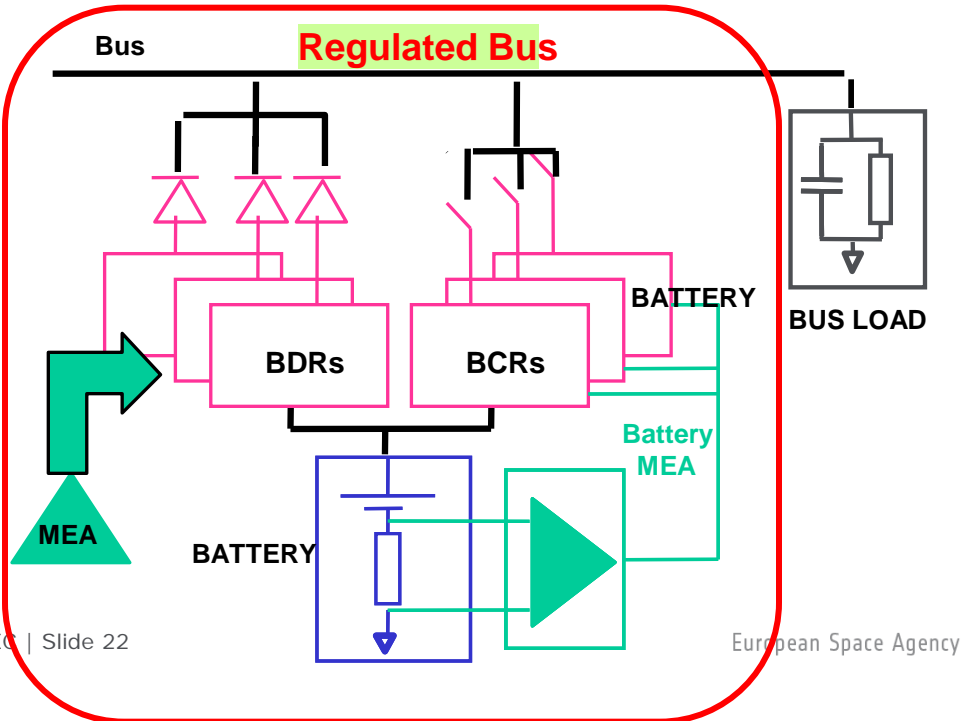
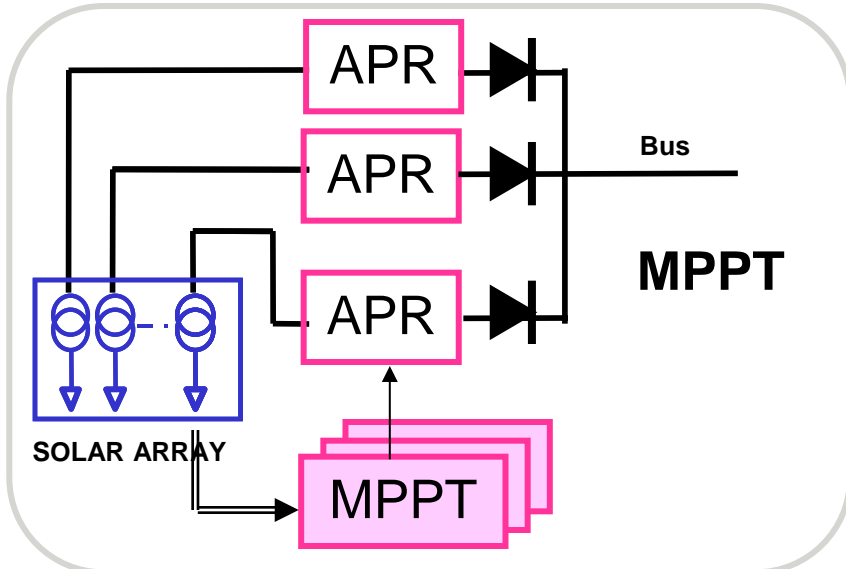
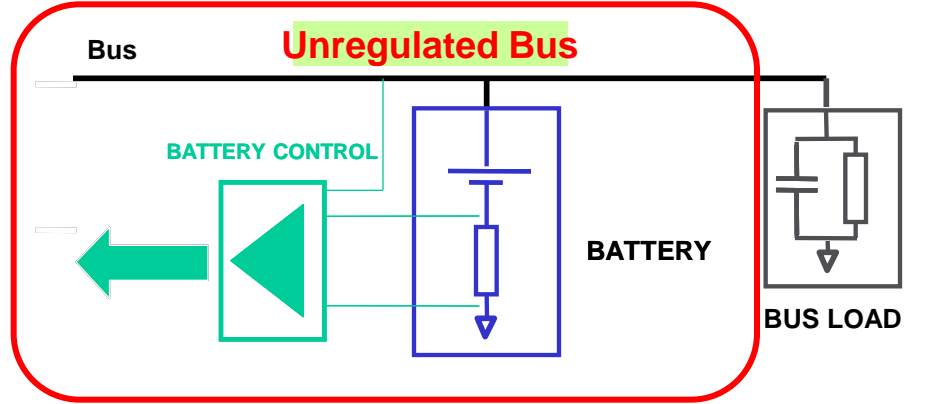
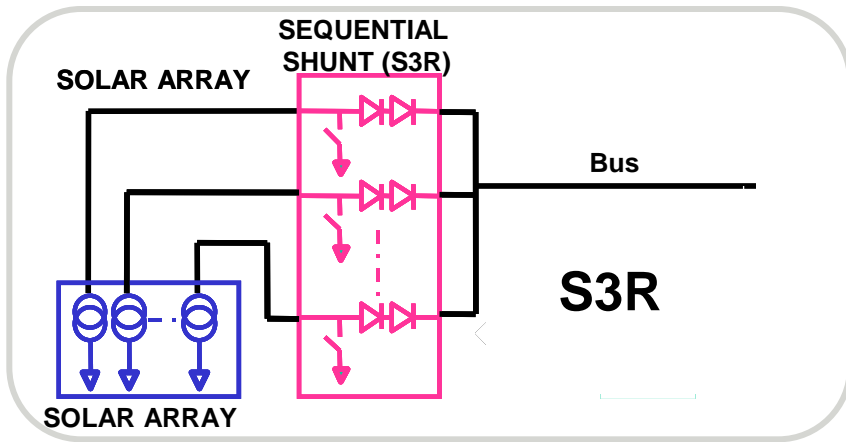
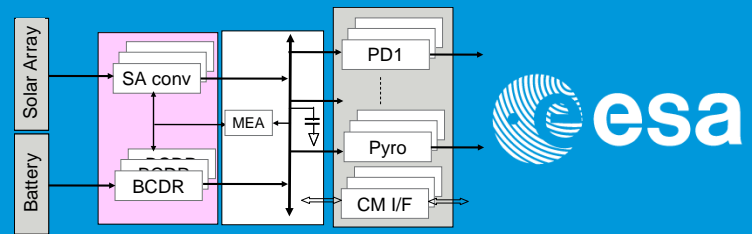

ECSS E ST 20C , Electrical Power Sub-System - distribution part (1/3)

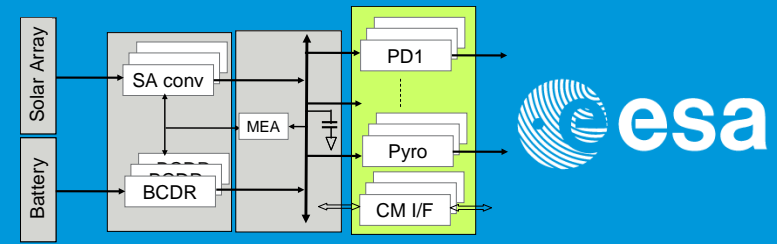

➤ Fuses

One shot device: no reset function, uncertainties of the fusing conditions wrt current & time.

The power system needs to be able to absorb the heavy transient resulting from a fuse blowing event.

=> Typically used in high recurrent telecom satellites platforms

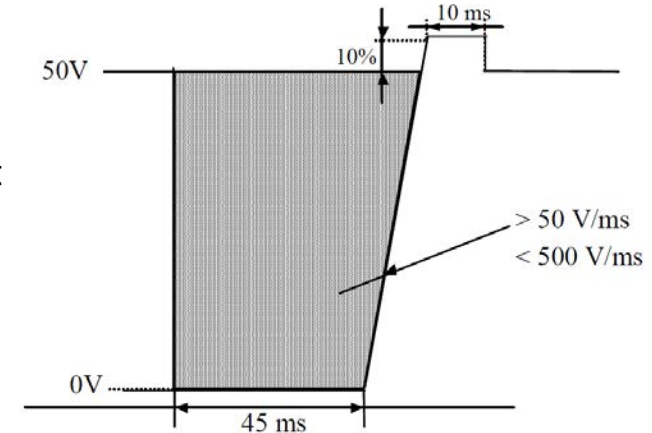

➤ Latching Current Limiters

The **LCL** is a solid state switch provided with **current limitation** (from a fraction of an Amp to several Amps).

It normally works in saturated mode (e.g. it presents a **small resistance in series** with the load current).

The voltage drop is kept typically within 1% of the nominal Main Bus voltage level.

In case of an overload on the line, the current limitation feature enters quickly into action, and the line is opened if the **overload duration** exceeds the **trip off time** (some ms to tens of ms).

The LCLs are usually protecting the **non essential loads**.

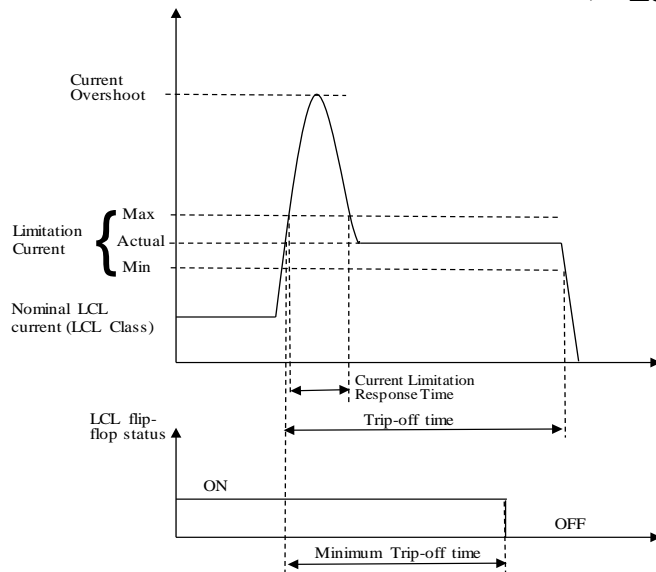

ECSS E ST 20C , Electrical Power Sub-System – distribution part (2/3)

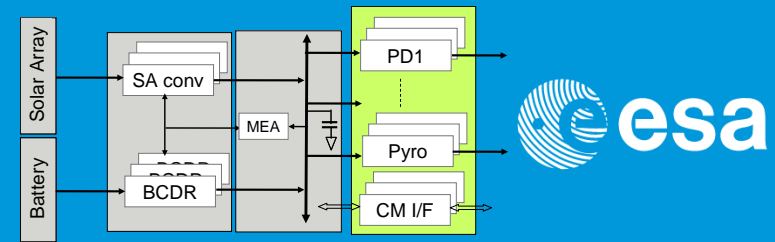

➤ Foldback Current Limiters (FCLs)

The FCL is a solid state device provided with a **foldback current limitation**. It is not a switching device and normally works in saturated mode (as the LCL).

In case of an overload on the line, the current is reduced according to the foldback characteristic.

The FCLs are usually protecting the **essential loads** (receivers, decoders in the on board data handling)

The present trend is to substitute FCLs with Retriggerable LCLs (RLCLs) especially for dissipation reasons in case of overload.

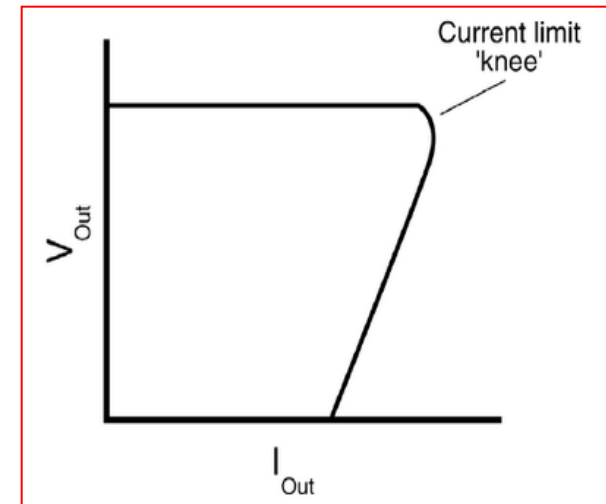

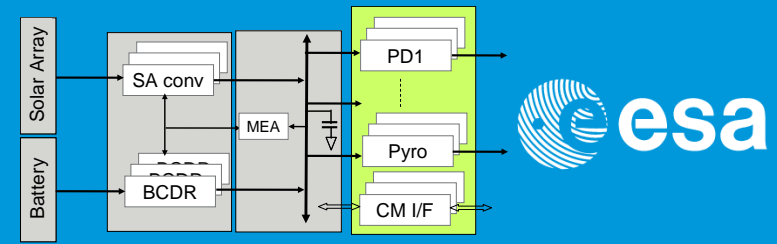

➤ Retriggerable Latching Current Limiters (RLCLs)

The **RLCL** is an LCL provided with retrigger capability.

It works in the same way described for LCL, but after the trip off event is automatically restarting if the overload persists.

The RLCLs are usually protecting the **essential loads**.

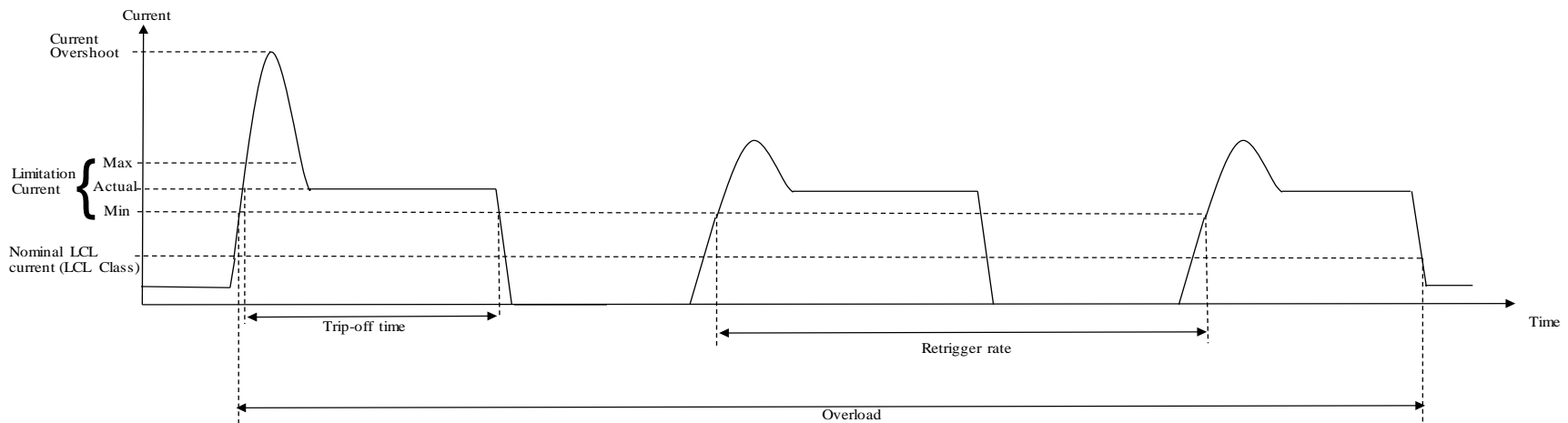

ECSS E ST 20 20C & relevant HB, (standard) interfaces for power distribution based on LCLs and RLCLs

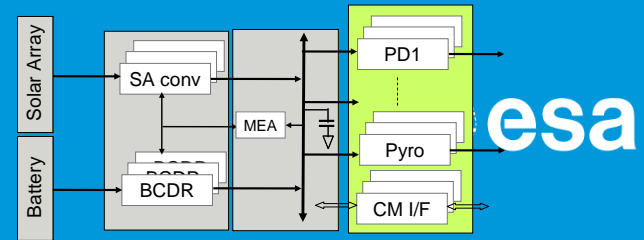

➤ parenthesis... first level three standard - STD - (and handbook! - HB -) to be mentioned:

ECSS E ST 20 20C & relevant ECSS E HB 20 20A, Electrical design and interface requirements for power supply

- In reality, both the STD and the HB deal specifically with (standard) interfaces for power distribution based on LCLs and RLCLs
 - Standard “plugs” power for all users on board of institutional spacecrafts!
 - **Product oriented** standard: enables availability of power distribution “products” with defined characteristics (classes & other features)
 - **Agreed** with Large System Integrators and Equipment Manufacturers!

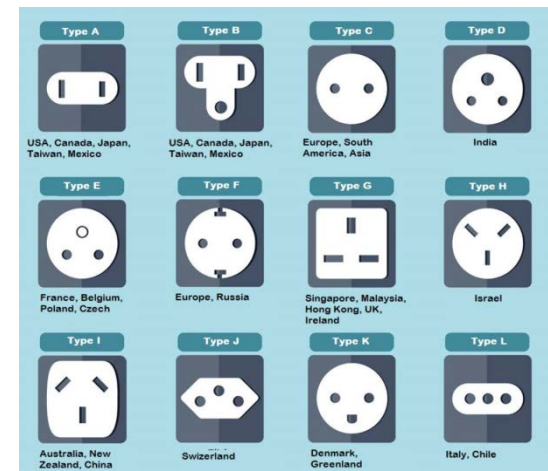

STD

- a. Conventional ECSS standard document...
- b. but with **summary synoptic table** (Requirement Mapping table, see Figure 6 below)
- c. Requirements grouped under following categories
 - **Functional, source** (section 5.2)
 - **Functional, load** (section 5.3)
 - **Performance, source** (section 5.4)
 - **Performance, load** (section 5.5)



Reference	Text of the requirement	Feature	Sub-feature	Conditions	Applicability	Applicability level	Verification
5.2.18.1.1a	The RLCL state shall automatically be recovered to ON conditions after a spurious switch OFF.	Noise immunity	RLCL spurious switch OFF	Nominal	RLCL	Equipment	RoD, 
5.2.18.2.1a	Spurious disable of RLCL retriggering memory cell and of RLCL ON/OFF status memory cell shall not result in the loss of the relevant load.		RLCL spurious effects	Nominal	RLCL	Equipment	RoD, 

Figure 6, Example of requirements mapping (from STD, Annex A)

HB

- a. **Explanatory** document (principles of operation, important issues)
- b. **Justification** of STD requirements
- c. **Key aspects**: interactions LCL and load (at start up, overload, switch-off conditions, both in time and in frequency domain, considering normal operational conditions but also failure cases)
- d. For the **system engineers**, this document explains the detailed issues at circuit level and the impacts of the requirements for the design of LCLs.

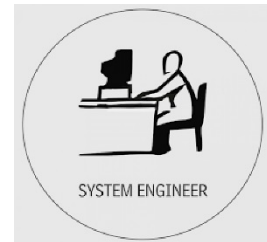

For **design engineers**, this document gives insight and understanding on the rationales of the requirements on their designs.

- a. For missions traditionally provided with power distribution and protection by LCLs/RLCLs (science, earth observation, navigation)
- b. for power systems, and in general for satellites, required to be **Single Point Failure Free**.
- c. to the main bus power distribution by LCLs/RLCLs to **external** satellite loads (no internal power system protections)

Table 1 - Reference Power Bus Specifications

Power Bus type :		REGULATED BUS [V]		UNREGULATED BUS [V]	
		28V	50V	28V	50V
Nominal DC Bus Voltage Range at regulation point	Min	28 -1%	50 -1%	22	32
	Max	28 +1%	50 +1%	38	52
Nominal DC Bus Voltage Range at load side	Min	28 -5%	50 -5%	22	38
	Max	28 +1%	50 +1%	38	52
Abnormal DC Bus voltage range	Min	0	0	0	0
	Max (fault tolerance)	N/A	N/A	40	55
	Max (fault emission)			38	52
Nominal Bus ripple voltage	Max	Acc. to ECSS-E-ST-20C		Up to ± 500 mVpp in the range of 30 Hz to 50 MHz.	
Nominal Bus voltage transients	Max	Acc. to ECSS-E-ST-20C		$\pm 1,4$ V for load steps of 50%, with $dI/dt=1A/\mu s$	$\pm 2,5$ V for load steps of 50%, with $dI/dt=1A/\mu s$
Abnormal Bus voltage transients	Max	0 to 34 max	0 to 60 max	Within Power Bus abnormal DC limits	

Other assumptions:

- maximum qualification temperature of the host unit is 70°C
- MB voltage derivative from 0 to 0.1V/ μs

ECSS-E-ST&HB-20-20C – LCL classes



Table 2: LCL classes

	LCL class									LCL class								
	1	2	3	4	5	6	8	10		1	2	3	4A	4B	5	6	8	10
Regulated Bus voltage [V]	28									50								
Unregulated Bus voltage [V]	22 to 38									32 to 52								
Class current [A]	1	2	3	4	5	6	8	10		1	2	3	4	4	5	6	8	10
Min limitation current [A]	1,1	2,2	3,3	4,4	5,5	6,6	8,8	11		1,1	2,2	3,3	4,4	4,4	5,5	6,6	8,8	11
Max limitation current [A]	1,4	2,8	4,2	5,6	7	8,4	11,2	14		1,4	2,8	4,2	5,6	5,6	7	8,4	11,2	14
Trip-off min [ms]	10	10	6	6	4	2	2	1,5		10	6	4	2	4	2	2	2	1,5
Trip-off max [ms]	20	20	12	12	8	4	4	3		20	12	8	4	8	4	4	4	3
Max load capacitance [µF]																		
Regulated bus	272	545	490	653	545	327	436	408		152	183	183	122	244	152	183	244	229
Unregulated bus	203	405	365	486	405	243	324	304		148	178	178	118	237	148	178	237	222

Table 3: RLCL classes

	RLCL class					RLCL class				
	0,5	1	2A	2B		0,5	1A	1B	2	
Regulated Bus voltage [V]	28					50				
Unregulated Bus voltage [V]	22 to 38					32 to 52				
Class current [A]		0,5	1	2	2		0,5	1	1	2
Min limitation current [A]		0,55	1,1	2,2	2,2		0,55	1,1	1,1	2,2
Max limitation current [A]		0,7	1,4	2,8	2,8		0,7	1,4	1,4	2,8
Trip-off min [ms]		10	10	4	10		10	4	6	4
Trip-off max [ms]		20	20	8	20		20	8	12	8
Max load capacitance [µF]										
Regulated bus		136	272	218	545		76	61	91	122
Unregulated bus		101	203	162	405		74	59	89	118

Table 4: HLCL classes

Characteristic	HLCL class									HLCL class								
	1	2	3	4	5	6	8	10	1	2	3	4	5	6	8	10		
Regulated Bus voltage [V]	28									50								
Unregulated Bus voltage [V]	22 to 38									32 to 52								
Class current [A]	1	2	3	4	5	6	8	10	1	2	3	4	5	6	8	10		
Min limitation current [A]	1,1	2,2	3,3	4,4	5,5	6,6	8,8	11	1,1	2,2	3,3	4,4	5,5	6,6	8,8	11		
Max limitation current [A]	1,4	2,8	4,2	5,6	7	8,4	11,2	14	1,4	2,8	4,2	5,6	7	8,4	11,2	14		
Trip-off min [ms]	0,5	0,5	0,5	0,5	0,5	0,5	0,5	0,5	0,5	0,5	0,5	0,5	0,5	0,5	0,5	0,5		
Trip-off max [ms]	2	2	2	2	2	2	2	2	2	2	2	2	2	2	2	2		
Max parasitic capacitance [μ F]																		
Regulated bus	1	1	1	1	1	1	1	1	1	1	1	1	1	1	1	1		
Unregulated bus	1	1	1	1	1	1	1	1	1	1	1	1	1	1	1	1		

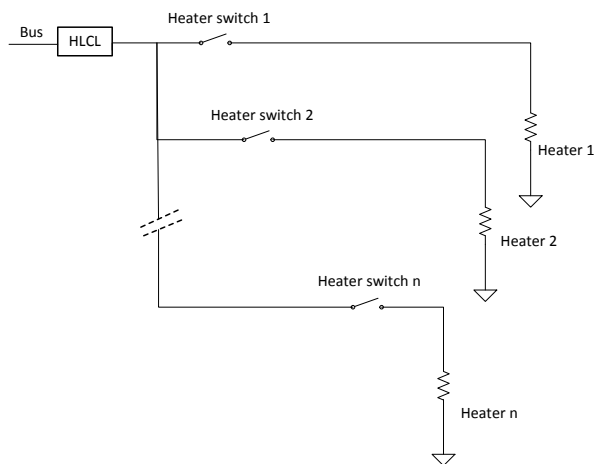

HLCL, or Heater (group) LCL

Figure 4, HLCL application

1. Electronics and power subsystem, key principles
 - a. Electronics for space
 - b. Space power subsystem
- 2. Key categories of requirements**
 - a. Reliability**
 - b. Functionality**
 - c. Performance**
3. Why/when/how to use the STD
4. Presentation of the main chapters
5. Key STD Definitions
6. Key STD requirements
7. Conclusions

1. Reliability

- a. In broad sense...
- b. Capability of equipment/subsystem/system to fulfil the required function after failures
- c. “Failure” management
- d. Management of redundancies and protections

1. Reliability

- a. In broad sense...
- b. Capability of equipment/subsystem/system to fulfil the required function after failures
- c. “Failure” management
- d. Management of redundancies and protections

Example...

STD req.4.2.1.w:

“The spacecraft electrical system shall be single point failure free (or double point failure free for manned mission), regardless of any occurrence of non destructive SEEs.”

1. Functionality

- a. Capability of equipment/subsystem/system to fulfil or serve the purposes for which it was designed, through design, manufacturing and verification phases

1. Functionality

- a. Capability of equipment/subsystem/system to fulfil or serve the purposes for which it was designed, through design, manufacturing and verification phases

Example...

STD req.4.1.3.b:

“All executable commands shall be explicitly acknowledged by telemetry.”

1. Performance

- a. Capability of equipment/subsystem/system to meet the specified scientific or engineering target, through design, manufacturing and verification phases

1. Performance

- a. Capability of equipment/subsystem/system to meet the specified scientific or engineering target, through design, manufacturing and verification phases

Example...

STD req.5.7.2.i:

“With a fully regulated bus in nominal operation the bus voltage transients shall:

- 1. for load transients of up to 50% of the nominal load not exceed 1% of its nominal value.***
- 2. for any source and load transients remain within 5% of its nominal value.”***

Why is that important to classify requirements according to

Reliability

Functionality

Performance?

The reason is that requirements on

- **Reliability** requirements are hidden design drivers, and their verification might be easily overlooked!
- **Functionality** might cover non obvious features of the equipment/subsystem/system, and it might also be easy that proper verification is overlooked
- **Performance** dictate the necessary engineering/scientific targets for mission success... but their verification can hardly be forgotten

1. Exercise

Identify in the STD

- a. One requirement on **reliability**
- b. One requirement on **functionality**
- c. One requirement on **performance**

=> Discussion

1. Electronics and power subsystem, key principles
 - a. Electronics for space
 - b. Space power subsystem
2. Key categories of requirements
 - a. Reliability
 - b. Functionality
 - c. Performance
- 3. Why/when/how to use the STD**
4. Presentation of the main chapters
5. Key STD Definitions
6. Key STD requirements
7. Conclusions

ECSS E ST 20C, why/when/how to use the STD



In general...

Why?

- a. Maybe it is a repetition, but it may be worth doing it ... the STD shall be applied **to enhance the chances of success** (e.g. to meet the specific performance, functionality and reliability targets of your electronic units and power subsystem).

When?

- a. The application of STD within ESA is indeed recommended **at the beginning of a satellite development** if a classical, top down approach is used to determine system requirements from mission ones, and subsystem/unit level requirements from higher level ones
- b. In case of subsystem/unit level “stand alone” R&D development the STD application is recommended **at the very beginning of the R&D development** itself (e.g. when TRL level is still low – below 4 or 5) because many of the requirements thereby contained are design drivers
- c. In case of off-the-shelf subsystem/unit level procurement, the STD application is recommended at the **negotiation phase**.

In general...

When (continued)?

- d. Do not forget that the STD may become useful in case of disputes with large system integrators and sub-contractors at any time, especially when critical deviations and non conformances appear as a result of HW test!

... keep it in your drawer...

How?

- a. A **compliance matrix** shall be produced to identify compliance status to each requirement, with **specific justification for any partial or non compliance**.

ECSS E ST 20C, why/when/how to use the STD

In particular...

... in the STD each requirement is specified **when, how, and where** it shall be verified (with reference to satellite classical procurement approach)

-> Example p51 of the ECSS EST20C.



Page 51

Table 5-3: General verification of electrical power requirements

Requirement	At the following verification points	Verification methods	Recorded in
	SRR: System requirements review PDR: Preliminary design review CDR: Critical design review TRR: Test readiness review TRB: Test review board DRB: Delivery review board AR: Acceptance review X: Preliminary formal verification point	RoD: Review of design T: Test A: Analysis INS: Inspection NOTES: RoD includes review of documentation	[1] Electrical ICD (including SAR ICD and Battery ICD). [2] Budget documents (e.g. Power, Energy, Processor, and memory budgets) [3] DDF or DJF [4] GDIR [5] Tests Reports [6] Specification [7] User manual
5.2.1a	PDR	RoD	[2]
5.2.2.1a	SRR	RoD, A, T	[3][5]
5.2.2.2a	PDR	RoD, A	[2][3]
5.2.2.2b	PDR	RoD, A	[2][3]
5.2.2.2c	PDR	RoD	[2]
5.2.2.2d	PDR	RoD	[3]
5.2.2.2e	PDR, AR	RoD, A	[2]
5.2.2.2f	PDR	RoD, A	[2][3]
5.3a	PDR	RoD	[3]
5.3b	PDR	RoD, A	[3]
5.3c	PDR	RoD, A	[3]
5.3d	PDR	RoD, A	[3]
5.4a	SRR	RoD	[1][4][6]
5.4b	PDR	RoD	[1][4][6]
5.4c	AR	A, T	[3][5]
5.4d	PDR	RoD	[1][4][6]
5.4e	PDR	A	[3]
5.5.2a	PDR	A	[2]
5.5.2b	PDR	A	[3]
5.5.2c	PDR	RoD, A, T	[3][5]
5.5.2d	PDR	RoD, A	[3]
5.5.2e	PDR	RoD, A	[3]
5.5.2f	PDR	T	[5]

1. Electronics and power subsystem, key principles
 - a. Electronics for space
 - b. Space power subsystem
2. Key categories of requirements
 - a. Reliability
 - b. Functionality
 - c. Performance
3. Why/when/how to use the STD
- 4. Presentation of the main chapters**
5. Key STD Definitions
6. Key STD requirements
7. Conclusions

ECSS E ST 20C, presentation of the main chapters

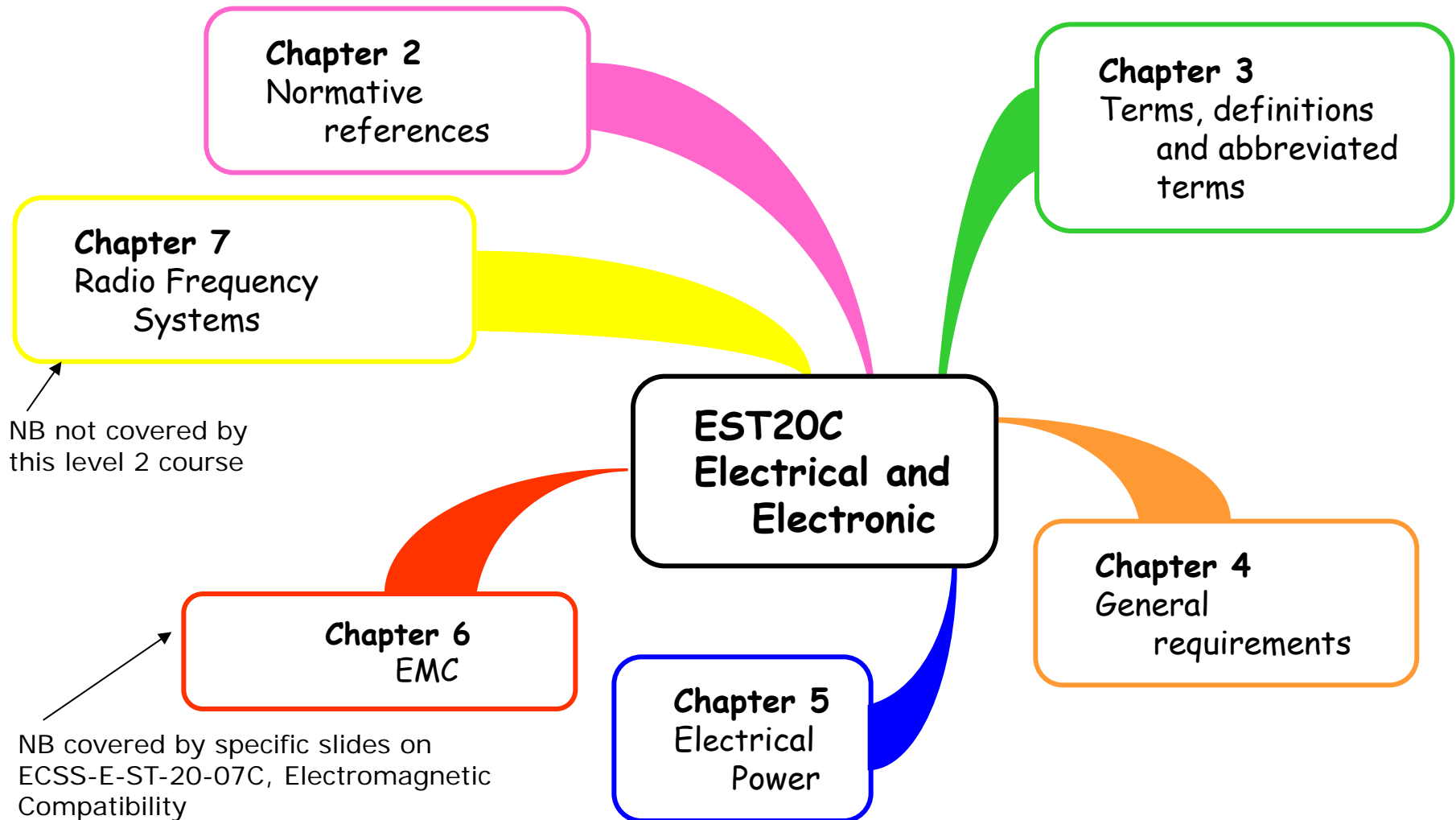

ECSS E ST 20C, presentation of the main chapters



Chapter 2
Normative references

Chapter 3
Terms, definitions and abbreviated terms

- Definitions used in the requirements
- Abbreviated terms commonly used during meetings and documents

EST20C
Electrical and Electronic

Chapter 7
Radio Frequency Systems

- Antennas
- RF Power
- Passive Inter-modulation

Chapter 4
General requirements

- Electrical Interfaces
- Generic Electrical Design

Chapter 6
EMC

- EMC Requirements in term of design
- System / equipment requirements

Chapter 5
Electrical Power

- Power subsystem / Budgets
- Failure containment / redundancy
- Electrical Power Interfaces
- Energy generation / Energy Storage
- Power Conditioning / Control / Distribution / Protection

• **Spacecraft requirements**

1. Electronics and power subsystem, key principles
 - a. Electronics for space
 - b. Space power subsystem
2. Key categories of requirements
 - a. Reliability
 - b. Functionality
 - c. Performance
3. Why/when/how to use the STD
4. Presentation of the main chapters
- 5. Key STD Definitions**
6. Key STD requirements
7. Conclusions

- Only some key definitions are hereby explained, they have been chosen according to specific issues making them that special...
 - a. depth of discharge (DoD)
 - b. double insulation
 - c. essential function
 - d. high priority telecommand
 - e. high voltage
 - f. single point failure free

Depth of Discharge (or DoD, 3.2.11)

- refers to battery technology.
- it is defined as

*ampere-hour removed from an initially fully charged battery expressed as a percentage of the **nominal nameplate capacity***

- nominal nameplate capacity is in turn defined (3.2.29) as
capacity stated by the manufacturer of an energy storage cell or battery, given in ampere-hours.

It is not necessarily equal to any measurable capacity.

Nameplate capacity

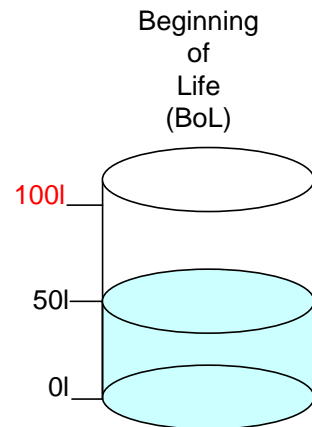

Ageing makes the bucket... shrink!

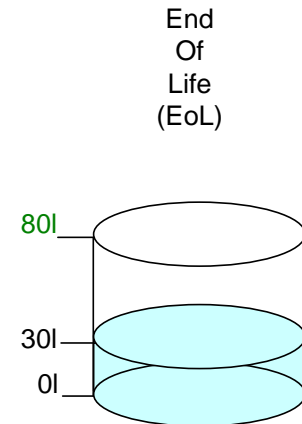
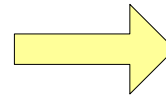

$$\text{DoD} = (100l - 50l) / 100l = 50\%$$

$$\text{DoD} = (80l - 30l) / 100l = 50\%$$

... but the % of actually removed volume is

$$(80l - 30l) / 80l = 62.5\% !!$$

Be careful to

1. use DoD properly !!!
2. ensure that your interlocutor (Prime, power system or battery manufacturer, etc) understands it and possibly uses the same DoD definition to avoid misunderstandings

Double Insulation (3.2.12)

- refers to electrical/electronic items.
- it is defined as

barrier between conductors or elements of an electronic circuit such that after any credible single failure, conductors or elements of an electronic circuit are still insulated from each other

- The following additional definition, although not present in the STD, can be useful

Critical lines are those electrical lines requiring, in case of failures, double insulation (either reciprocal or with respect to another conductor) to avoid catastrophic effects or other undesirable consequences

- *Repeat of the main DI definition:*
 - *“barrier between conductors or elements of an electronic circuit such that **after any credible single failure**, conductors or elements of an electronic circuit are still insulated from each other”*
- *Importance of identifying the credible single failure!*
- *Risk = Severity* Probability*
- *Dependant on technology, interface, manufacturing, handling (or mishandling), operator’s mistakes and accidents, cleanliness...*

1. Applicability of Double Insulation requirements

- a. to prevent **single** insulation failures* that may generate or propagate anomalies with critical consequences (catastrophic or anyhow unacceptable consequences) at mission level.
- b. Not only **flight** equipment, but also ground support equipment to exclude dramatic effects of single insulation failures affecting flight hardware (through connection interfaces)

2. DI is a overhead...

it shall be applied only when and where it is needed... on “critical lines” of course



Adobe Acrobat
Document

* SPFF (Single Point Failure Free) approach generally applies

Essential Function (3.2.19)

- refers generally to electrical/electronic items, but it could be extended to other items
- it is defined as

function without which the operator cannot recover the spacecraft (following any conceivable on-board or ground-based failure), the spacecraft cannot be commanded, the spacecraft permanently loses attitude and orbit control, the spacecraft consumables (e.g. fuel and energy) are depleted to such an extent that more than 10% of its lifetime is affected, or the safety of the crew is threatened

Essential Function (3.2.19)

- Which are essential functions in the terms expressed by the STD?
 - easily identifiable if the “function” **corresponds** to a unit:
satellite receivers, transmitters, OBDH, battery, etc
 - less obvious when the “function” is **internal** to a unit:
Solar Array Regulator (SAR), Battery Charge and Discharge Regulators (BCR, BDR), Main Error Amplifier in the PCDU, but also Reconfiguration Module or Decoder in CDMU.

High Priority (tele)Command (HPC, 3.2.23)

- refers to electrical/electronic items
- it is defined as

command originated from ground and issued by the telecommand decoder for essential spacecraft functions without main on board software intervention

- It is important to stress that it is the sort of command that needs to be actuated *without any software intervention*, HPC's are normally used in contingency cases to access redundancy of essential functions as per previous definition

High Voltage (HV, 3.2.23)

- refers to electrical/electronic items or wires/harness
- it is defined as

AC or DC voltage at which partial discharges, corona, arcing or high electrical fields can occur

- To understand the underlying phenomena, and to know which are the threats of HV in space applications, watch the following:

[Paschen movie](#)

Single Point Failure Free (SPFF)

- Unfortunately it is not in the list of definitions, it appears in req. 4.2.1w (specifically discussed later in this presentation)
- In STD it refers to any electrical/electronic item, but it can be applied to any spacecraft part
- SPFF is intended as

the quality of a item that is able to maintain its functionality and performance after any single (internal) failure

Single Point Failure Free (SPFF), discussion

- The way any electrical/electronic item would maintain its functionality and performance after any single failure is by *redundancy* and *protections*

- What is important to mention in reference to the SPFF definition is
 - a. Which are the “failures” we want to be robust against?*

 - b. Is it **autonomous reconfiguration** of the SPFF item applicable ?*

Single Point Failure Free (SPFF), which “failures”?

- In theory, **any** possible failure shall be covered
- But any sensible person understands that this is **practically impossible to achieve** (a requirement shall be always verifiable...)
- The way the problem is resolved by dependability is to refer to a practical set of failure cases, which are **defined at EEE component level***
- **Note that this is the basis of the electrical reliability of our spacecrafts!**
- The very important messages here are the following
 - Please adopt a EEE components failure mode catalogue for any project you might be involved (STD req.5.11.2b)*
 - Please support the availability of FMECA performed at component level for any essential electrical/electronic unit which you might review or procure (STD req.5.11.2c)*

* See annex G of ECSS-Q-ST-30-02C



Single Point Failure Free (SPFF) approach, is it *autonomous reconfiguration* applicable?

- That is an important point to be clarified as soon as possible in the life cycle of a space mission
- In the case of a new satellite procurement, define the strategy of autonomy versus failures possibly in the Mission Requirement Document (MRD) or in the System Requirement Specification (SRS)
- Other implications of autonomy vs SPFF approach are discussed in relation to req. 4.2.1w.

1. Electronics and power subsystem, key principles
 - a. Electronics for space
 - b. Space power subsystem
2. Key categories of requirements
 - a. Reliability
 - b. Functionality
 - c. Performance
3. Why/when/how to use the STD
4. Presentation of the main chapters
5. Key STD Definitions
6. **Key STD requirements ...**
....NB, only a small, non exhaustive set of key requirements!
7. Conclusions

Reliability, Functionality, Performance

Table of contents

Where we are...

Change log	3
1 Scope.....	8
2 Normative references	9
3 Terms, definitions and abbreviated terms.....	10
3.1 Terms from other standards	10
3.2 Terms specific to the present standard	10
3.3 Abbreviated terms	15
4 General requirements.....	17
4.1 Interface requirements	17
4.1.1 Overview.....	17
4.1.2 Signals interfaces	17
4.1.3 Commands	18
4.1.4 Telemetry.....	19
4.2 Design	20
4.2.1 Failure containment and redundancy	20
4.2.2 Data processing.....	22
4.2.3 Electrical connectors	22
4.2.4 Testing.....	23
4.2.5 Mechanical: Wired electrical connections.....	24
4.2.6 Dependability.....	24
4.3 Verification.....	25
4.3.1 Provisions	25
4.3.2 Documentation	25

Key requirement #1

4 General requirements

4.2 Design

4.2.1 Failure Containment and redundancy

1. In the case of hot redundant essential functions, either latching protection shall not be used, or it shall have an autonomous periodic reset.

Explanation:

The requirement typically applies to the overload/current protection features saving the main bus from load failure, when the load is an essential function operating in hot redundancy (for example, the reconfiguration or command decoder in the CDMU).

In this case, the overload protection cannot be a latching type, on the contrary you might risk to lose one side (M or R) of the critical function with catastrophic consequences due to spurious EMC, ESD, SEE triggering.

Key requirement #2

4 General requirements

4.2 Design

4.2.1 Failure Containment and redundancy

1. Override of critical onboard autonomous functions shall be implemented only if a safety interlock is implemented which prevents the activation of the override feature on both main and redundant functions.

Explanation:

By default, and to avoid errors that would be fatal to the mission, an automatism shall be implemented that switches ON (or does not allow the switch OFF) the redundant side of a critical on board autonomous function when the main side is switched OFF.

Example

The switches commanding ON/OFF the (two essential) receivers in the spacecraft.

Key requirement #3

4 General requirements

4.2 Design

4.2.1 Failure Containment and redundancy

w. The spacecraft electrical system shall be single point failure free (or double point failure free for manned mission), regardless of any occurrence of non destructive SEEs.

Explanation:

By default, any ESA satellite is considered as SPFF (DPFF for manned missions).

SEEs might cause the spurious activation of protections that would affect essential functions (as for example the Battery Discharge Regulator in a power system) and this shall not be considered as a failure case.

Pause... again on SPFF approach

The approach towards failure management on ESA satellites is a very important *technological, design* and *cost/schedule* driver.

It is extremely important that the approach is **agreed** with the Prime **as soon as applicable** (e.g. at system requirement review)

SPFF is our standard option, but this does not mean that it could not be waived

Key requirement #4

4 General requirements

4.2 Design

4.2.3 Electrical connectors

a. A connector carrying source power or external test connectors on units shall have no contact areas exposed to possible short circuit during mating and de-mating process.

Issue:

Sometimes (e.g. for a battery) the power is necessarily exposed on both sides!

In this case, round-type connectors are preferred over "D" types. There are also other interesting options (see ESCC Detail Specification No. 3401/081 to 084)

In the picture you see to a flight battery connector, damaged because of wrong mating.



Pause... again on connectors

4 General requirements

4.2 Design

4.2.3 Electrical connectors

- Two requirements* address the dreadful **loss of a critical connector**... the main issue is to establish a clean and robust verification and validation approach of the relevant fixation to be sure that it would not happen during launch and flight (on the contrary, use round connectors with locking mechanism)

*

m. The following shall be performed for any connector the loss of which can lead to the loss of the mission:

- 1. Document the connector in the single point failure list***
- 2. Verify its integrity up to the highest spacecraft integration level***

n. The accidental de-mating of connectors (where it is a realistic case) or any internal connector failure shall not lead to catastrophic consequences.

On redundancy testing

4 General requirements

4.2 Design

4.2.4 Testing

- Some requirements** address the **(necessary) testing of redundancies** and of some protections that are **contained within a unit**. The redundancies test is essential to be sure that your SPFF approach is alive at the time you launch the spacecraft!
- Note that these **testing requirements** are **design drivers**, since you need to be able to “inject” stimuli simulating a failure.

** See next chart...

On redundancy testing

4 General requirements

4.2 Design

4.2.4 Testing

* *

d. The functionality shall be provided to test the redundant function of a closed unit.

g. The redundancy of parts and functions, which failure can lead to the loss of the mission or human injury, shall be verified by test simulating the failure event.

h. Stimuli points on equipment and payload shall not provoke unwanted operation.

i. The protection of functions, which failure can lead to the loss of the mission or human injury, shall be verified by test simulating the failure event.

m. Redundant functions and protection functions within a unit shall be verified by test at unit level.

2. Exercise

What if... I do not follow requirements 4.2.4 d,g,h,l,m previously mentioned?

=> Discussion

Where we are...

5 Electrical power	29
5.1 Functional description	29
5.2 Power subsystem and budgets	29
5.2.1 General	29
5.2.2 Provisions	29

- 5.2 Power subsystem and budgets
 - 5.2.2 Provisions
 - 5.2.2.2 Engineering process

A set of requirements (a. to d.) is dedicated to **power and energy budgets**, to be produced and maintained **both** for **peak** and for **average** power demand.

They are important but intuitively easy to understand (so no specific discussion).

ECSS E ST 20C, energy generation, key requirements



Where we are...



ECSS-E-ST-20C
31 July 2008

5.3	Failure containment and redundancy	30
5.4	Electrical power interfaces	31
5.5	Energy generation	31
5.5.1	Solar cell, coverglass, SCA and PVA qualification	31
5.5.2	Solar array specification and design.....	31
5.5.3	Solar array power computation.....	33
5.5.4	Solar array drive mechanisms	35
5.6	Electrochemical Energy Storage	35
5.6.1	Applicability.....	35
5.6.2	Batteries	35
5.6.3	Battery cell.....	37
5.6.4	Battery use and storage	38
5.6.5	Battery safety.....	38

The key requirements that relate to function and performance are intuitively easy to understand

- a solar array has to generate power
- aspects which have to be addressed in the power calculation are itemised

The key requirements relating to **reliability** require some more thought....

The electrical components included in order to assure reliability are:

- **Bleed resistor**
- **Blocking diodes**
- **Shunt diodes**
- **Redundant connections**

Key requirement #5

5.5 Energy generation

5.5.2 Solar array specification and design

e) NOTE Good practices in accordance with the present state of the art, are to:

...

- *implement string blocking diodes*

...

Explanation:

- Blocking diodes prevent flow of current from the bus to the solar array in case the string output voltage is less than the bus voltage.

Example:

- A string is unable to maintain the bus voltage in photovoltaic mode e.g. due to partial shadow. In the absence of a blocking diode, this string would sink power.

Key requirement #6

5.5 Energy generation

5.5.2 Solar array specification and design

i. In the flight configuration, bleeding resistors shall be implemented.

Explanation:

- Bleed resistors limit flow of current from the solar array to ground in case of short to the solar array panel substrate
- They also limit differential charging between solar panel and spacecraft body e.g. due to different secondary electron emission rates

Example:

- Failure of insulation between solar cells and panel substrate e.g. due to micrometeorite impact

Key requirement #7

5.5 Energy generation

5.5.2 Solar array specification and design

q. Solar cells shall be protected against any deleterious reverse bias conditions.

Explanation:

- For triple-junction cells, each cell must be protected by a dedicated **by-pass diode** since unprotected reverse bias operation would usually cause component failure. The reverse voltage of the cell is limited to the forward voltage of the by-pass diode junction.

Example:

- Within one string which is operating in photovoltaic mode, one cell is partially shadowed and forced to operate in reverse-bias in order to conduct the string current

ECSS E ST 20C, electrochemical energy storage, key requirements



Where we are...



ECSS-E-ST-20C
31 July 2008

5.3	Failure containment and redundancy	30
5.4	Electrical power interfaces	31
5.5	Energy generation	31
5.5.1	Solar cell, coverglass, SCA and PVA qualification	31
5.5.2	Solar array specification and design.....	31
5.5.3	Solar array power computation.....	33
5.5.4	Solar array drive mechanisms	35
5.6	Electrochemical Energy Storage	35
5.6.1	Applicability.....	35
5.6.2	Batteries	35
5.6.3	Battery cell.....	37
5.6.4	Battery use and storage	38
5.6.5	Battery safety.....	38
5.7	Power conditioning and control	39
5.7.1	Applicability.....	39
5.7.2	Spacecraft bus.....	39
5.7.3	Battery Charge and Discharge Management	42

The key requirements that relate to function and performance are intuitively easy to understand

- An electrochemical cell has to store the energy
- An electrochemical cell has to provide energy when the solar power is not available or not sufficient during all the mission phases

Reliability is related to the cell construction and the battery assembly.

A lot of care has to be paid on the **expected** versus **qualified** environmental conditions, and on integration aspects.

ECSS E ST 20C, electrochemical energy storage, key requirements

Key requirement #8

5.6 Electrochemical energy storage

5.6.3 Battery cell

g. The battery supplier shall inform the customer of any change in design, materials or process from cells which have experienced life testing or flight.

Explanation:

A review of the cell construction is necessary before starting an overview of the battery construction and to consider the failure modes of the battery. Any change in materials, processes, design can have impacts on the reliability.

Example:

Any change in tabs or protection devices like PTC will affect the reliability of the cell

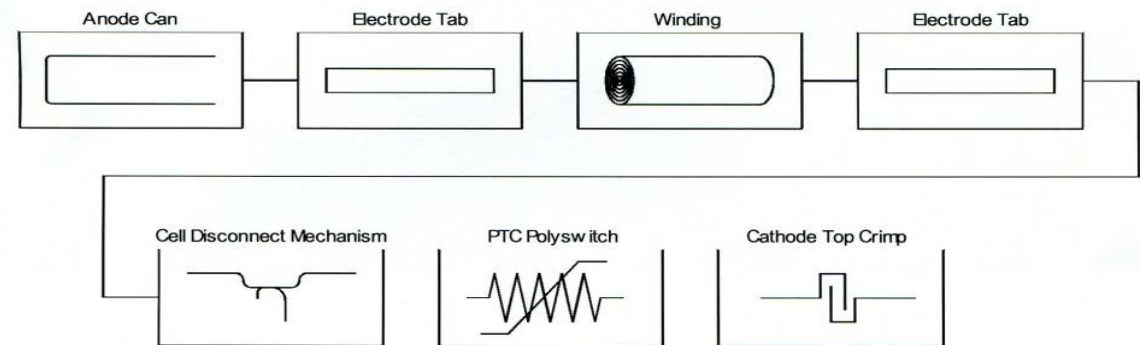

Figure 3-1: Cell Reliability Block Diagram

Key requirement #9

5.6 Electrochemical Energy Storage

5.6.2 Batteries

a. Batteries shall be designed to support the spacecraft through the launch sequence, including all anticipated contingencies and through all foreseen losses of solar energy during the mission, including those resulting from failures.

Explanation:

Batteries must meet requirements in all phases of the mission. It is very important to find worst cases that are leading to battery sizing. If a mission phase is overlooked, battery sizing may be incorrect.

Example:

LEOP, safe mode might be the battery **sizing driver** *more* than nominal operational mode

Key requirement #10

5.6 Electrochemical Energy Storage

5.6.2 Batteries

m. Battery Thermal design shall ensure that

1. maximum and minimum qualification temperature of cell operation under intended cycling conditions are not exceeded

...

Explanation:

If cells are cycled outside their temperature range, their performance is affected in term of cycle life, rate capability

Example:

Rate (Ah) capability at 0°C is different from the rate capability at 15-20°C

ECSS E ST 20C, electrochemical energy storage, key requirements



1. AIT

- Live battery connector was allowed to touch the wall of TV chamber

2. Is the battery flight worthy?

- How do you ensure the cell was not overdischarged?
- Were PTC (resettable cell protection against high current, external shorts) activated? if yes, how to be sure these PTC are exactly identical as previously and will play fully their role in the future?
- Impacts on reliability?
- Impacts on performance?

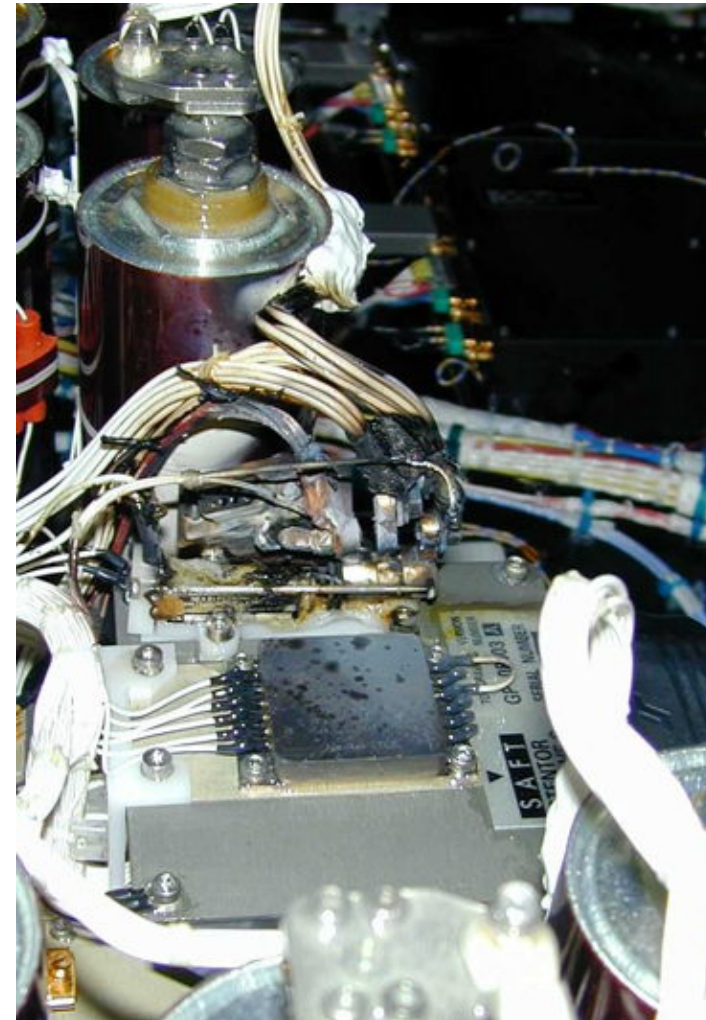

Key requirement #11,12,13

5.6 Electrochemical Energy Storage

5.6.4 Battery use and storage

- c. Flight batteries should not be used for ground operations to prevent any possible damage and subsequent degradation of life performance.***
 - **i.e. Battery simulators should be used whenever possible.**
 - At most flight batteries need only be used for mechanical and thermal vacuum testing

- f. Any cell, which has experienced an electrical, mechanical, or thermal level outside the qualification range shall be flagged and tracked***
- g. Any cell, which has experienced an electrical, mechanical, or thermal level outside the qualification range should be forbidden for flight.***
 - It is not always easy to assess impacts on reliability and performance at EoL when a cell has been tested outside its qualification range.
 - Flying such a cell represents a risk that must be assessed before declaring the battery flight-worthy.

Key requirement #14

5.6 Electrochemical Energy Storage

5.6.2 Batteries

- I. A logbook shall be maintained by the supplier for each flight battery starting with the 1st activation after battery assembly...*

NOTE The logbook is used for the following purposes:

- to ensure compliance with storage, handling and operational requirements before launch (e.g. maximum time allowed at upper temperature limits, correct scheduling of maintenance activities);
- to allow verification of flight worthiness.
- special care has to be paid to external current discharge paths during integration phases.

Be careful to properly **fill in the logbook**.

It will help to assess battery health status, especially in case of an anomaly during testing.

Logbook is overlooked and usually... empty, if it even exists!

ECSS E ST 20C, power conditioning and control, key requirements



Where we are...

5.6	Electrochemical Energy Storage	35
5.6.1	Applicability	35
5.6.2	Batteries	35
5.6.3	Battery cell	37
5.6.4	Battery use and storage	38
5.6.5	Battery safety	38
5.7	Power conditioning and control	39
5.7.1	Applicability	39
5.7.2	Spacecraft bus	39
5.7.3	Battery Charge and Discharge Management	43
5.7.4	Bus under-voltage or over-voltage	44
5.7.5	Power converters and regulators	44
5.7.6	Payload interaction	46
5.8	Power distribution and protection	46
5.8.1	General	46
5.8.2	Harness	48
5.9	Safety	49
5.10	High voltage engineering	50
5.11	Verification	50
5.11.1	Provisions	50
5.11.2	Documentation	50

ECSS E ST 20C, power conditioning and control, key requirements



The power conditioning and control electronics part of the power subsystem has to accomplish the following

- shall **condition, control, monitor and distribute** electrical power from the solar generator to the spacecraft users
- shall **manage battery charge / discharge** to fulfill satellite power demands throughout all mission phases in the presence of all environments actually encountered
- shall be **capable of operating continuously** under all operational conditions of the mission including contingency situations. No damage or degradation shall result from intermittent or cycled operation
- shall provide **adequate status monitoring and telecommand interfaces** necessary to operate the sub-system and permit evaluation of its performance (during ground testing and in-flight operations) and failure detection and recovery.

ECSS E ST 20C, power conditioning and control, key requirements



The power conditioning and control electronics subject that is required by the STD has the following features:

- a. It is **SPFF** versus its functional and performance requirements in all phases of the mission including integration ones
 - Req. 5.7.2 a,b,e,f,r,s; 5.7.3 b,c,i; 5.7.4 d,e; 5.7.6 b,d; 5.8.1 a,c,d,i,j,k
- b. In its basic features, it is **fully autonomous** and **self-contained**
 - Req. 5.7.2 c,d; 5.7.3 g,h; 5.7.4 c
- c. It is **able to start from either of** irrespective if the other is able to
 - Req. 5.7.2 q
- d. It respects **stringent performance** compatibility issues with power source
 - Req. 5.7.2 g,h,i,k,m,n,o,p; 5.7.3 a; 5.8.2 e,f; 5.10 b,c,d,e

The background idea is to have a subsystem for which protection and recovery is implemented in hardware (as ultimate resort before loss of mission or other catastrophic effects).

This applies especially for ESA projects...

ECSS E ST 20C, power conditioning and control, key requirements



Key requirement #15

5.7 Power conditioning and control
5.7.2 Spacecraft bus

a. At the point of regulation, the impedance mask of a fully regulated bus, operating with one source shall be below the impedance mask shown in Figure 5.1.

Explanation:

The requirement is strictly related with the dynamic transient performances required from a regulated bus (see 5.7.2i). In particular,

- the **plateau** of the impedance (from 100Hz to 10KHz) is derived from a simple calculation, in order to allow a maximum 1% main bus voltage fluctuation for a load modulation up to 50%.
- The behaviour **over 10KHz** results from the bandwidth limitation of the power subsystem voltage control loop (assumed to be 10KHz) and the effect of the capacitor bank at high frequencies.
- the behaviour **below 100Hz** results from assumed proportional-integral power subsystem voltage control loop (with a zero at 100Hz) and the residual effect of the connection resistance from regulation point to output connector at frequencies below 10Hz.

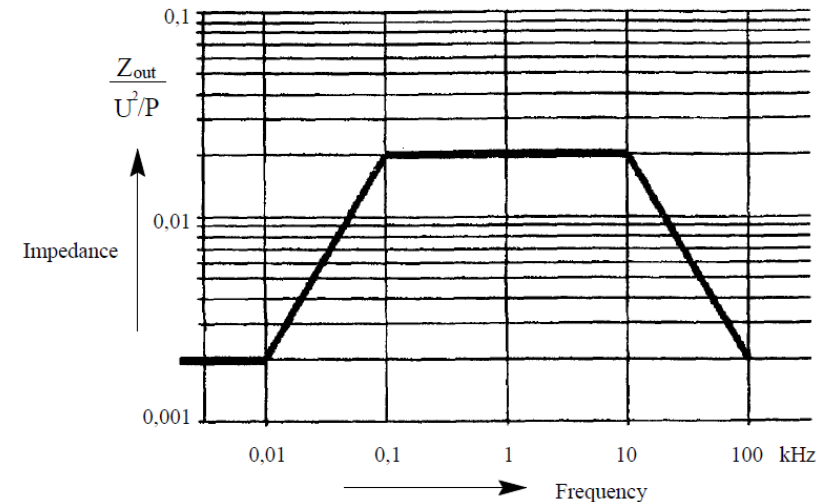

3. Exercise

What if... I do not respect the impedance mask requirement 5.7.2a?

=> Discussion

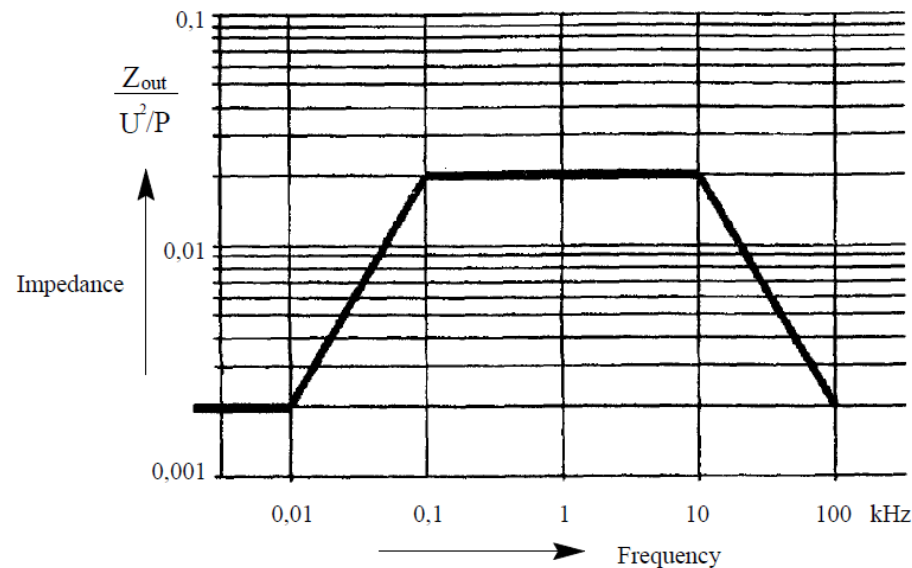

U = Nominal regulated output voltage (Volt)

P = Power capability (Watt)

Key requirement #16

5.7 Power conditioning and control

5.7.3 Battery Charge and Discharge Management

a. Battery chargers shall be designed to ensure charging of a battery discharged down to zero volts.

Explanation:

Unfortunately this requirement might be misunderstood... the correct meaning is that the battery chargers shall be **able to recharge a battery** that is **completely drawn** (e.g. that it has been depleted to a negligible state of charge).

The reason of this requirement is to be sure that our satellites can indeed recover from a major power loss (dead bus case, see SOHO experience)... it is a minor design request can save from disaster!

Key requirement #17

5.7 Power conditioning and control

5.7.4 Bus under-Voltage or over-voltage

c. The ultimate non-essential load disconnection circuit shall be implemented as a full hard-wired chain from sensor to actuator.

Explanation:

As previously explained, there should be a hardware safety net to save the mission from disaster, like there are hard-wired braking possibility in a car provided with a servo-braking system.

Over this hard limit, there are no prescription on how load disconnection shall be performed.

More details are given in the attached file

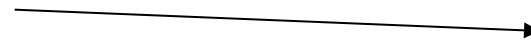

UV protections

ECSS E ST 20C, power conditioning and control, key requirements



Key requirement #18

5.8 Power distribution and protection
5.8.1 General

b. Whenever two or more blocks are connected in cascade, the stability of the cascade between each source block and load block shall be ensured by:

- 1. meeting the Nyquist criterion or,***
- 2. demonstrating that $|Z_{Source}| \ll |Z_{Load}|$ by one decade***

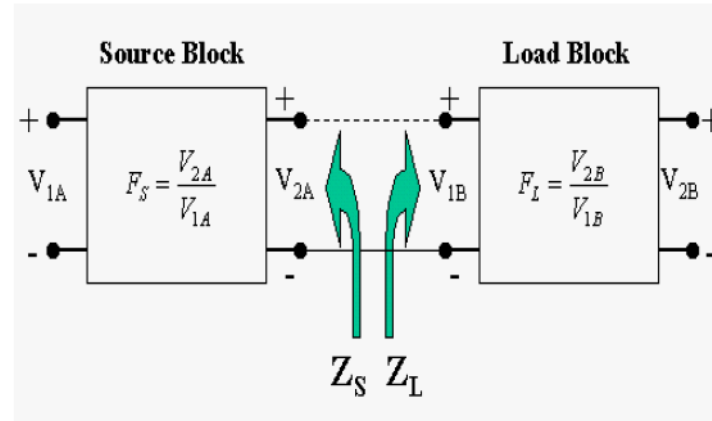

$$F_{SL} = \frac{F_S F_L}{1 + H_m}$$
$$H_m = \frac{Z_{Source}}{Z_{Load}}$$

Explanation:

The requirement applies to all power source –load combinations that you might encounter within or outside the power subsystem (SA-PCDU, BATT-PCDU, LCL-Load, etc). Starting from the assumption that both source and load block do meet stability requirements, it is *not necessary true* that their cascade would be stable.

Stability is a must (on the contrary our system will not behave as expected and additional stress on components, unexpected failures and failure propagation patterns would appear).

More details in the attached file.



Stability of
cascaded blocks

What happens if 5.8.1b is not ... *verified*:

We are not sure that stability is met!

ECSS-E-ST-20-06C, Spacecraft Charging

TEC-EES

ESA-ESTEC
rev1.0

1. Document

ECSS-E-ST-20-06C Spacecraft Charging, issue 11 July 2008
Part of ECSS-E-ST-20C Electrical and Electronic engineering

2. Scope of the document

- Applicable to all spacecrafts, subject to tailoring
- Covers the electrical charging of spacecraft and surfaces due to the space environment (not ground or atmospheric effects)
- Gives requirements to assess, and avoid or acceptably minimize hazardous effects of spacecraft charging

Space is not empty.

- It is filled with 'plasma' (electrons and ions) of low density but high temperature ($\sim 1 \times 10^8 \text{K}$ or 10keV in GEO)
- Even higher energy particles ($\sim \text{MeV}$) are in the radiation belts
- The environment varies with location and 'space weather'

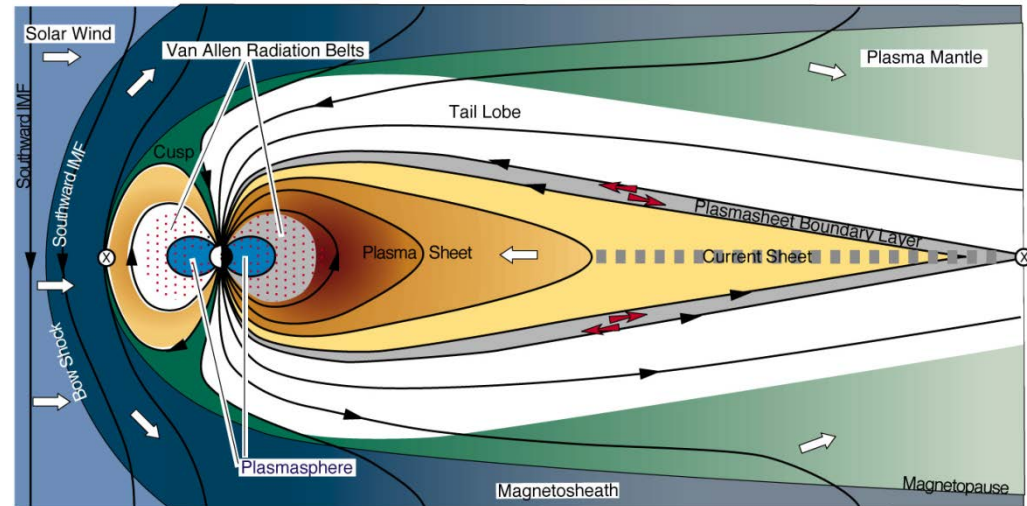

These charged particles stick to the spacecraft, charging it electrically.

Sparks (electrostatic discharges) from one charged surface to another interfere with and damage electrical circuits and components.

- **Many** spacecraft **failures** and **anomalies** have resulted.

Both the environment and materials play a role in spacecraft charging

1. ECSS-E-ST-10-04C Space Environment standard describes the aspects of the space environment that have a crucial influence on spacecraft charging. In particular:
 - a. **Plasma** – ions and electrons, 0eV to ~50keV
 - b. **Energetic particle radiation**, ~100keV to ~5MeV
 - c. Sunlight – ejects negative charge by photoemission
2. Materials differ in terms of **conductivity** and yield of **secondary emission** and **photo-emission**.

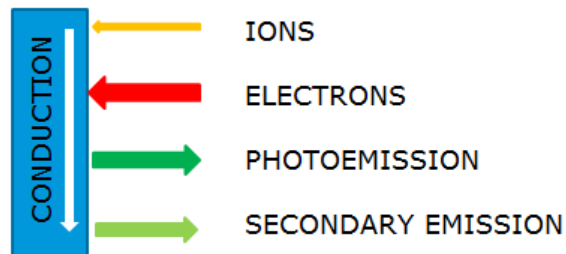

Surface potential arises from the **total current** from electrons, ions, photoemission, secondary emission, conducted current and more...

Important: Different surfaces reach different potentials.

Most critical engineering concerns

1. Surface charging due to charge accumulation on **external** surfaces. High levels of differential potential may lead to Electrostatic Discharge (ESD).
2. **Internal** charging due to more energetic penetrating electrons. ESDs may be generated within the spacecraft Faraday cage and in close proximity to vulnerable components.
3. ESDs on the **solar array** can cause secondary arcing

Additional concerns include

1. Current leakage and power loss effects on solar arrays
2. Environment modification. Can be a critical problem for scientific plasma measurements
3. Electric propulsion interactions with the environment
4. Electrostatic tethers current collection and voltage generation

See clauses 6 to 11 of the standard for detailed requirements

'Platinum' requirements

1. Dielectric materials at not more than -1kV w.r.t. conductors (6.2.1)
2. Dielectric materials at not more than +100V w.r.t. conductors (6.2.1)
3. Internal electric field not more than 10MV/m (6.2.1)
4. An ESD on the solar array shall not lead to a sustained arc (7.2.3.1)

Other requirements are principally derived from these, including:

- Grounding of conductors
- Selection of leaky insulators
- Selection of high photo/secondary emission yield materials
- Testing of solar arrays

ECSS E ST 20 06C, Spacecraft Charging, Protection programme



There needs to be a **plan** for assessments **to demonstrate that requirements are met** (Clause 5)

Requirements may be shown to be satisfied in the design by:

- Simple analyses e.g. $\text{voltage} = \text{worst-case current} \times \text{resistance}$
- Computer simulation of spacecraft charging
- Laboratory testing under vacuum irradiation

The design must be verified by measurement, inspection and testing e.g. checking the grounding of MLI thermal blankets

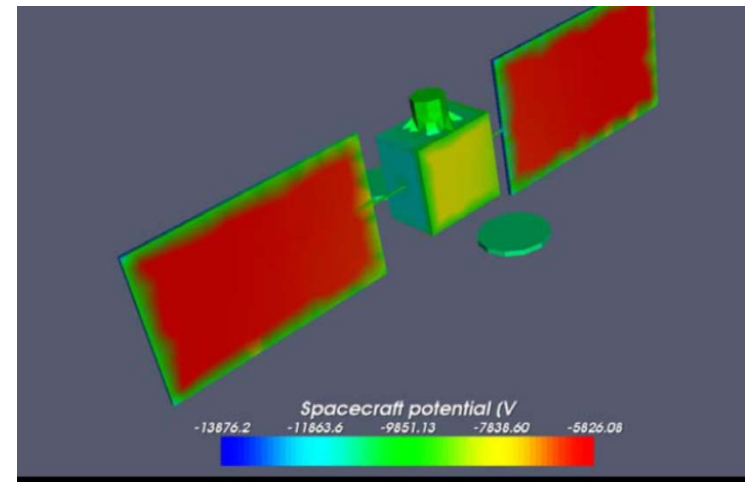

ECSS E ST 20 06C, Spacecraft Charging, Tailoring



- Different requirements apply in different orbits because of their different environments (Annex B)
- LEO
 - Surface charging (clause 6) **for scientific s/c only**
 - Solar array ESD effects (clause 7)
 - High-voltage interactions (clause 8)
- PEO
 - Surface charging (clause 6) **with some relaxation**
 - Solar array ESD effects (clause 7)
 - High-voltage interactions (clause 8)
- MEO/GEO
 - Surface charging (clause 6)
 - Solar array ESD effects (clause 7)
 - **Internal parts and materials** (clause 9)

- Special requirements apply for
 - Electrodynamic Tethers - (clause 10)
 - Electric propulsion – (clause 11)
- Interplanetary missions and non-Earth planetary environments
 - Not specifically covered by the standard but the 'platinum' requirements are still relevant

ECSS-E-ST-20-07C Rev. 1

Electro-magnetic compatibility

TEC-EEE
ESA-ESTEC
Issue 1.0

ECSS-E-ST-20-07C Rev. 1

Electromagnetic compatibility, introduction



E-20 discipline Electrical and optical engineering

E-ST-20C
Electrical and electronic

E-20-01A
Multipaction design and test

E-ST-20-06C
Spacecraft charging

E-ST-20-07 Rev. 1
Electromagnetic compatibility

E-ST-20-08C
Photovoltaic assemblies and components

ECSS-E-ST-20-07C Rev. 1
7 February 2012



Space engineering

Electromagnetic compatibility

Documents of interest

- **ECSS-E-ST-20C (Ch. 6)**, called "20C" in this presentation
- **ECSS-E-ST-20-07C Rev. 1**, called "20-07C" in this presentation

ECSS-E-ST-20-07C Rev. 1

Electromagnetic compatibility, introduction



1. Additional documents of interest

ECSS-E-HB-20-07A, EMC handbook

Throughout the presentation, the requirements further discussed in the EMC handbook (ECSS-E-HB-20-07A) are tagged with [HB] + relevant section #.

HB

ECSS-E-ST-20-07C Rev. 1

Electromagnetic compatibility, brief history



Brief history

Birth of the ECSS-E-ST-20-07C Rev. 1

1999: ECSS Standard, Electrical and Electronic

ECSS-E-20A: one chapter (Ch. 6) is about EMC

2004: Introduction of “level 3” ECSS standards,
appointment of a WG drafting the ECSS-E-20-07A

2008: ECSS Standard, Electromagnetic Compatibility

Release of the ECSS-E-ST-20-07C (new reference)

2012: ECSS Standard, Electromagnetic Compatibility

Release of the **ECSS-E-ST-20-07C Rev. 1**

General remarks:

- Some heritage from US DoD military standards
- Most heritage from European space projects EMC requirements (but correcting recurrent anomalies)
- “General system EMC requirements” are still in the **ECSS-E-ST-20C, Ch. 6**

General system requirements are in the ECSS-E-ST-20C, chapter 6

E-ST-20C
Electrical and
electronic

1. Key requirement #1 (20C, clause 6.2.1 Overall EMC programme)

HB
5.1

- a. *The supplier shall establish an overall EMC programme*
- b. *The EMC programme shall allow verifying that:*
 - *design and management controls are organised to achieve EMC control*
 - *verification at spacecraft-level is planned and carried out*

2. Key requirement #2 (20C, clause 6.2.2 EMC control plan)

HB
5.1.4

- a. *As part of the EMC programme, the supplier shall write an EMC control plan (“EMCCP”) for the PDR.*
- b. *The EMC control plan shall apply to every item of equipment and subsystem in the project.*



3. Key requirement #3 (20C, clause 6.3.2.2 EMC with the launch system)

- a. The EM environment seen by the spacecraft ("S/C") & the EMC requirements during pre-launch and launch phases shall be according to applicable launchers user's manuals ("UM")*

E-ST-20C
Electrical and
electronic

NOTE: Specific EMC requirements during pre-launch & launch phases are in a contractual Interface Control Document established between launcher and S/C.

4. Key requirement #4 (20-07C, clause 5.3.3 in Ch. 5 Verification)

- a. If the S/C is not powered during launch, EMC testing with the launch system need not be performed.*
- b. If the S/C is powered during launch, the E-field RE requirements specified in the Launcher UM, including intentional transmission, shall be verified.*
- c. If a S/C RF Tx is operating under fairing, the following shall be verified:*
- 1. EMISM [margin] w.r.t the susceptibility threshold of the EEDs.*
 - 2. EMISM w.r.t the spacecraft RF receivers' susceptibility threshold (if operational) or damage threshold (otherwise).*
- d. The EMISM between the launch system RF emissions and the spacecraft RF receivers' damage threshold shall be verified.*

E-ST-20-07C Rev. 1
Electromagnetic
compatibility



HB
5.3.1.4

HB
5.3.2.4.1

5. Key requirement #5 (20C, clause 6.3.5 Intra-system EMC)

E-ST-20C
Electrical and
electronic

- a. The space system shall operate without performance degradation in the electromagnetic environment due to on-board sources (intentional or not).*

6. Key requirement #6 (20-07C, clause 4.2.8 Intra-system EMC)

- a. Intra-system EMC shall be achieved by:*

E-ST-20-07C Rev. 1
Electromagnetic
compatibility

- 1. allocation of equipment-level EMI requirements documented in the EMCCP, including:*
- a) limits on conducted and radiated emission*
 - b) limits on susceptibility*

NOTE: Recommended limits are in Annex A for equipment and subsystems.

NOTE 1: in the Annex A of the ECSS-E-ST-20-07C Rev. 1, emission and susceptibility limits are **not normative** but **informative**, so part of early project work is to decide on a set of consistent limits.

HB
5.1.2

NOTE 2: it is recommended to identify possible compatibility issues as early as the first half of phase B and to derive ad hoc requirements.

HB
5.1.3

Detailed system requirements are in the 20-07C, Ch. 4.2

E-ST-20-07C Rev. 1
Electromagnetic
compatibility

7. Key requirement #7 (20-07C, clause 4.2.13.2 Cable shields)

a. *Bonding of cable shields shall be as follows:*

1. *Bonding to chassis ground is performed at both ends:*

- a) *through the equipment connector body,*
- b) *using backshell that provides for circumferential bonding of shields, or using a halo-ring.*

b. *Overshields shall be bonded to chassis ground:*

1. *at both ends,*
2. *using a 360° direct contact.*

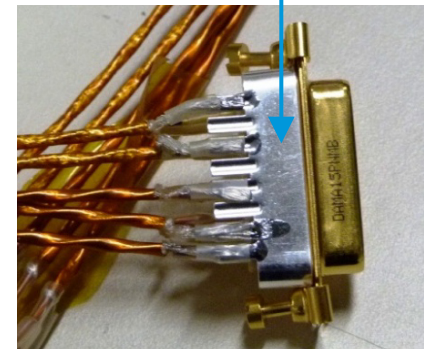
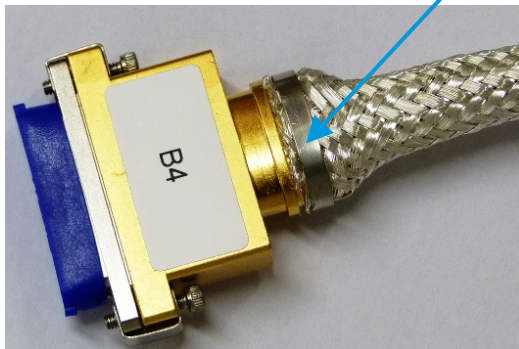

HB
5.2.4

ECSS-E-ST-20-07C Rev. 1, Equipment and subsystem test procedures



Equipment and subsystem level EMC test procedures [methods] are specified in the 20-07C, chapter 5.4

E-ST-20-07C Rev. 1
Electromagnetic
compatibility

Limits in the 20-07C are informative | **Test methods are normative**

HB
4

HB
5.1.2.3

Informative limit, Annex A	Title of test procedure	Verification clause
A.2	CE on power leads, differential mode, 30 Hz to 100 kHz (1st part)	5.4.2
A.2	CE on power leads, differential mode, 100 kHz to 100 MHz (2nd part)	5.4.3
A.3	CE on power leads, in-rush currents	5.4.3.4
A.4	CE on power and signal leads, common mode, 100 kHz to 100 MHz	5.4.3
A.5	<i>CE on antenna ports</i>	<i>Project specific</i>
A.6	DC magnetic field emission	5.4.4.4
A.7	<i>RE, low-frequency magnetic field</i>	<i>Project specific</i>
A.8	<i>RE, low-frequency electric field</i>	<i>Project specific</i>
A.9	RE, electric field, 30 MHz to 18 GHz	5.4.6
A.10	CS, power leads, differential mode, 30 Hz to 100 kHz.	5.4.6.4
A.11	CS, power and signal leads, common mode, 50 kHz to 100 MHz	5.4.7.4
A.12	CS, power leads, short spike transients	5.4.9
A.13	RS, magnetic field, 30 Hz to 100 kHz	5.4.9.4
A.14	RS, electric field, 30 MHz to 18 GHz	5.4.10.4
A.15	Susceptibility to electrostatic discharge	5.4.11.4

1. For the qualification of equipment, Emission & Susceptibility **limits** in the 20-07C are only informative (contrary to the test methods that are normative), so they all have to be defined.
2. It is always necessary to tailor RE and RS requirements to the characteristics of **RF transmitters and receivers** on-board:
 - a. RE requirements to the frequency band of RF receivers, and to the maximum acceptable interference level (HB 5.1.3.2.2.a)
 - b. RS requirements to the frequency band of RF transmitters, and to the transmitted power level (HB 5.1.3.2.2.b)

HB
5.1.2

HB
5.1.3

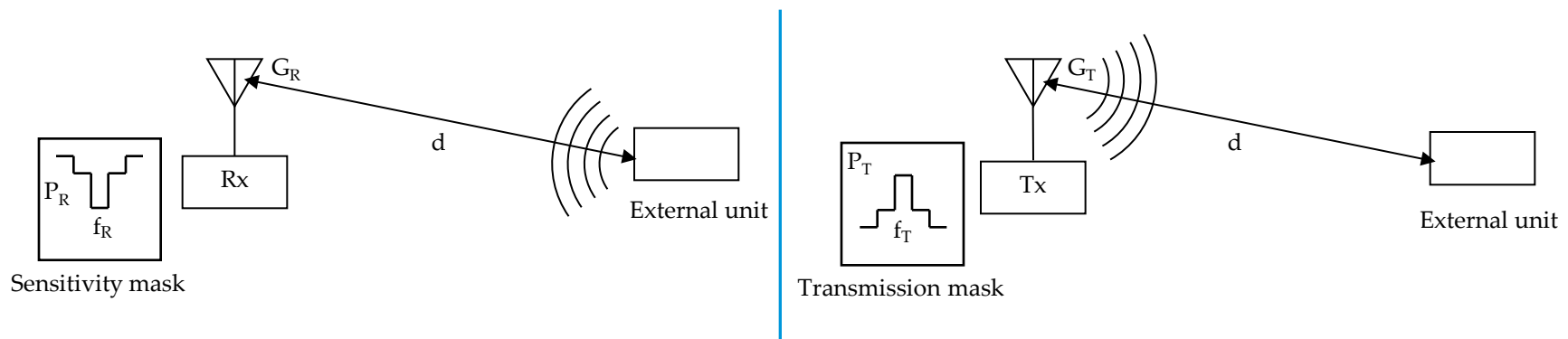

ECSS-E-ST-20-07C Rev. 1, Example of tailoring (and apportioning)

Tailoring and apportioning of DC magnetic requirements

1. Design AND verification methods have to be specified as part of a **magnetic cleanliness** programme
2. Magnetic moment requirements are apportioned according to:
 - a. Equipment **location**
 - b. Equipment **size**
 - c. **Technology**

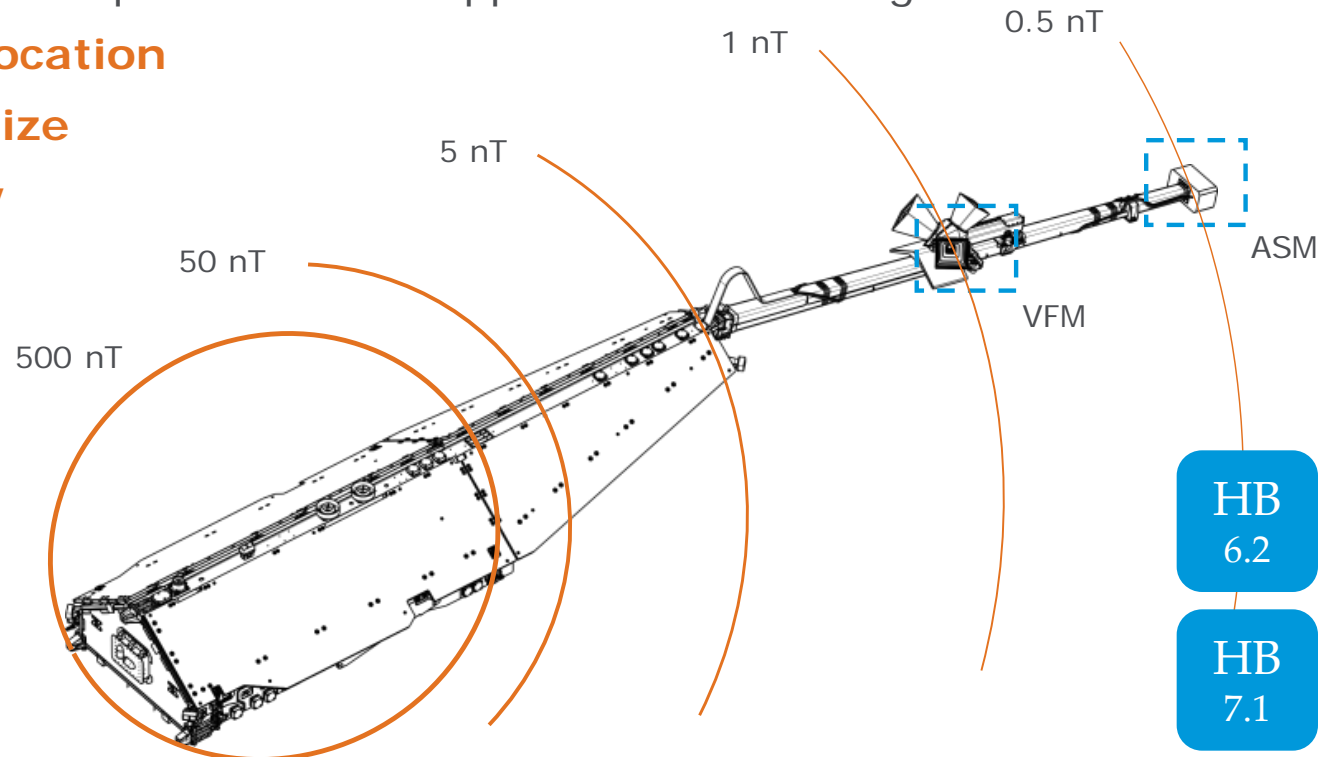

HB
6.2

HB
7.1

ECSS E-ST-20-08C Rev. 1

Photovoltaic Assemblies and Components

TEC-EPG
ESTEC
27/11/2012

1. This Standard outlines the requirements for the **qualification, procurement, storage and delivery** of the **main assemblies and components** of the space **solar array electrical layout**: photovoltaic assemblies, solar cell assemblies, bare solar cells, coverglass and protection diodes.
2. This standard **does not** cover the particular **qualification** requirements for a **specific mission**.
3. Rules for the flow of technical requirements from a project solar array specification are defined down to component level to guarantee that lower level components and sub-assemblies are qualified according to specifications.
4. On the other hand, the qualification of a specific level of assembly is based on the use of qualified components and sub-assemblies at lower levels.
5. Therefore, the qualification programme assures that the specific sub-assembly or component meets the requirements defined for a particular application.
6. Engineering and qualification requirements at higher solar array integration levels (panels & wings) are specified in ECSS-E-ST-20C and ECSS-E-ST-10-03C.

The Photo Voltaic Assembly (**PVA**) coupon is the power generating network, which includes **all electrical components**, integrated **on a flight representative solar array substrate**.

PVA coupons shall be submitted to the following qualification programme to demonstrate:

Fatigue Thermal cycling: The life fatigue compatibility of all electrical connections between the different components. Includes Thermal Vacuum (TV) and Ambient Pressure Thermal Cycling testing (APTC).

Long term storage: The endurance in a real-life environment against standard environmental conditions using accelerated tests. Includes Humidity and Temperature testing.

ESD: The use of adequate design rules to reduce risk of ESD.

Four point Bending test: That the compression and tension stress do not exceed the limits specified for the thermal conditions corresponding to the design dimensioning case.

Critical points: Electrical network stability under TV, definition of APTC temperature profile & number of cycles and definition of main ESD test parameters (primary discharge duration and S/C and SA capacitances)

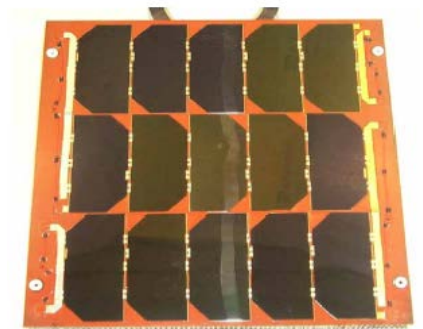

PVA Coupon – Front Side

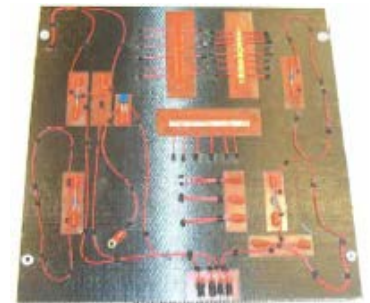

PVA Coupon – Rear Side

The **SCA** is the assembly of the **bare solar cell**, integrated (welded or soldered) **interconnectors** and bonded **coverglass** with transparent resin.

SCAs shall be submitted to the following qualification programme to demonstrate:

Front/rear interconnector adherence: The interconnectors adherence strength after thermal cycling (Interconnector pull tests)

BOL performance data and UV exposure: The solar generator sizing Beginning Of Life performance data and UV exposure compatibility.

EOL performance data: The solar generator sizing with End Of Life performance data. (Electron irradiation tests).

Surface conductivity and humidity: The SCA surface conductivity stability at EOL (after humidity and electron irradiation tests).

Life Test: The SCA power generation stability under worst case operation conditions for long duration.

Critical points: UV exposure coverglass glue transmission losses and high fragility of bare cells with front interconnectors to be submitted to pull tests. Activation energy for life test conditions definition

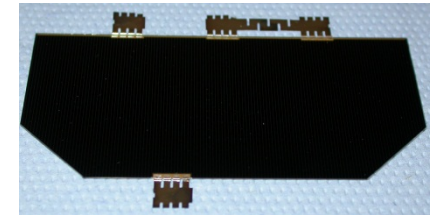

SCA – Front Side

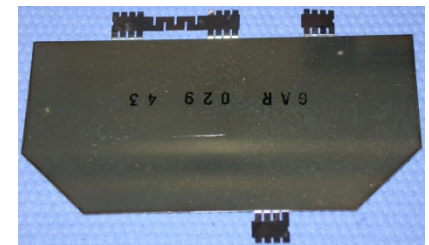

SCA – Rear Side

Bare Solar Cell Qual. Level

The **bare solar cells** is a semiconductor based component that generates electrical power under illumination.

Bare solar cells shall be submitted to the following qualification programme to demonstrate:

Front/rear contact adherence: The interconnector welding/soldering compatibility of the solar cell metallic electrical contacts.

BOL performance data: The solar generator sizing Beginning Of Life performance data.

EOL performance data (Electrons): The solar generator sizing End Of Life performance data for mono-energetic electron irradiation doses.

Extended storage simulation: The endurance of solar cell coatings and metallic electrical contacts in real-life environment against standard environmental conditions using accelerated tests.

EOL performance data (Protons): The proton radiation damage coefficients or characterize for EOL condition on specific mission.

Critical points: Electrical contacts and coatings stability under humidity and solar cells handling (fragile) during testing.

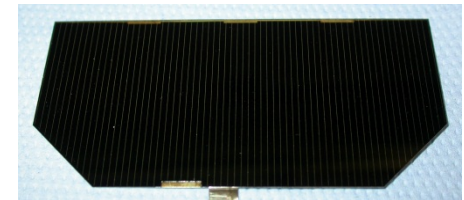

Bare cell – Front Side

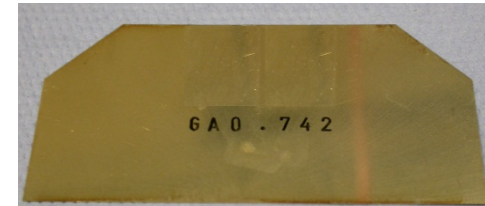

Bare cell – Rear Side

The **coverglass** is a component that protects the solar cell from the space environment. Coverglasses shall be submitted to the following qualification programme to demonstrate:

Physical characterization of substrate material: The uncoated glass in air transmission and electro-optical properties.

Mechanical & BOL performance data characterizations: The transmission into air and glue, electro-optical, thermo-optical and mechanical properties.

Coating adherence: The coating stability under boiling water test.

Humidity and temperature coating stability: The extended storage simulation with thermal cycling.

UV exposure: The coating stability under UV radiation.

Electron irradiation: Coating/glass stability under electron irradiation.

Proton irradiation: Coating/glass stability under proton irradiation.

Breaking strength: The glass strength to breakage.

Critical points: Coatings stability under humidity and UV exposure and coverglass handling (fragile) during testing.

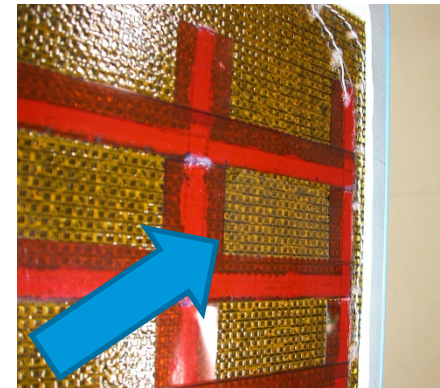

Coverglass ready for thermal cycling test

Solar cell protection diode Qual. Level

The protection diode is a component that connected in anti-parallel to the cell prevents electrical cell operation in reverse mode. Integral protection diodes (IPDs) are part of the solar cell structure and External Protection Diode (EPDs) are a separate component.

Protection diodes shall be submitted to the following qualification programme to demonstrate:

Electron irradiation and switching: stability under EOL conditions and robustness against electrical transients on ground and in-orbit.

Extended storage simulation: The endurance of metallic electrical contacts in real-life environment against standard environmental conditions using accelerated tests.

Contact adherence and ESD: The interconnector welding/soldering compatibility of the diode contacts and robustness against human body electrostatic discharges.

Life Test: The stability under worst case operation for long duration. For IPDs some of these tests are done at bare or SCA level.

Critical points: Diode of activation energy for life test conditions definition. Acceptance test electrical requirements.

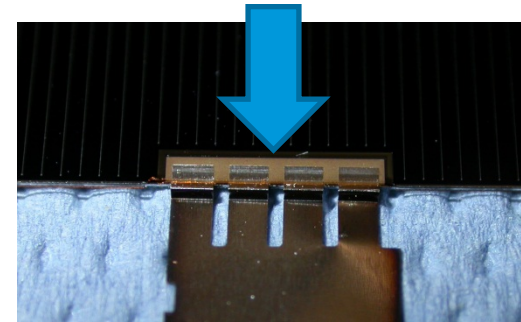

IPD Integral protection diode, with interconnector.

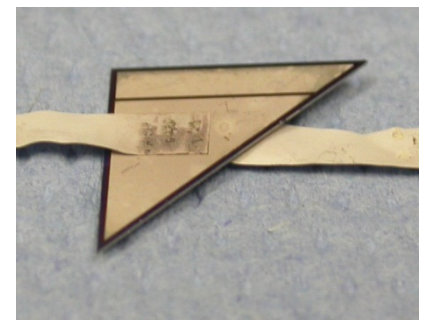

EPD External protection diode, with interconnector.

Example of Tailoring (1)



A generic **qualification** programme for a PVA technology from a specific supplier was carried-out fully in accordance to ECSS-E-ST-20-08C requirements for a **GEO** mission (15 years).

The same supplier shall carry-out the following **delta-qualification** programme to qualify a similar PVA technology (same bare solar cell, same protection diode, same coverglass, different interconnector, different solar array substrate) for a **LEO** mission (5 years):

PVA Coupon:

- Fatigue thermal cycling test to be performed on dedicated coupon according to the mission temperature profile and number of cycles.
- Four point bending test to be performed.
- ESD (more stringent in GEO) and Humidity (Storage) are covered by generic qualification.

SCA:

- Front and rear interconnector adherence after thermal cycling to be performed.
- EOL performance data to be performed (generic qualification has a different radiation level).
- BOL performance data to be performed due to a different interconnector material and UV exposure is covered by the generic qualification.
- Surface conductivity and humidity are not performed on coverglass without conductive coatings.
- Life test to be performed because of the different interconnector material (different soldering and welding parameters).

Bare Solar Cell:

- Front/rear contact adherence to be performed due to different interconnector material.
- BOL performance data covered by generic qualification.
- EOL performance data (Electrons) is covered by the LEO SCA delta-qualification (see above).
- Extended storage simulation shall be performed due to the different thermal cycling environment.
- EOL performance data (Protons) covered by generic qualification.

Protection diode:

- Electron irradiation and switching to be performed as electron radiation is different and the electrical transients on ground and in-orbit maybe different for the LEO mission.
- Extended storage simulation shall be performed due to the different thermal cycling environment
- Contact adherence and ESD to be performed because of different interconnector material. Human body ESD is covered by generic qualification.
- Life test to be performed because of the different interconnector material (different soldering and welding parameters).

Coverglass:

- Physical characterization of substrate material, Mechanical & BOL performance data characterizations, Coating adherence, UV exposure, Proton Irradiation and breaking strength are covered by generic qualification.
- Humidity and temperature coating stability to be performed due to the different thermal cycling environment.
- Electron irradiation is covered by generic qualification as the GEO radiation level is higher than for LEO.

The E 20 STD's have been briefly presented.

- **Key principles and definitions,**
- **key categories of requirements,**
- **some of the key requirements and some hints on tailoring**

have been presented, together with the basic ideas that inspired the E 20 STD's chapters and the relevant requirements.

For more details and for support on the utilisation of the STD's, please refer to ESA-ESTEC

- **TEC-EP division (power systems) and specifically**
 - **TEC-EPG for power generators (solar arrays)**
 - **TEC-EPB for energy (electrochemical) storage**
 - **TEC-EPM for power management and distribution (electrical and electronics)**
- **TEC-EPS for space environment and effects (spacecraft charging)**
- **TEC-EPE for electromagnetic compatibility**

Thanks for the attention!

I wanted specially to thank Evelyne Simon (TEC-EPB) and Stephen Taylor, Emilio Fernandez Lisbona (TEC-EPG) for their contribution in this presentation

Ferdinando Tonicello

TEC-E, Power Management and Distribution Lead Engineer

Ferdinando.Tonicello@esa.int

Tel. +31.71.565.5442

ECSS E 20 series tutorial, acronym list



APR	Array Power Regulator	EPD	External Power Diode	Pyro	Pyrotechnic (device)
APTC	Ambient Pressure Temperature Cycling	EPS	Electrical Power System	R&D	Research & Development
ASM	Absolute Scalar Magnetometer (SWARM satellite)	ESA	European Space Agency	RE	Radiated Emission
BATT	Battery	ESD	Electro Static Discharge	RF	Radio Frequency
BCDR	Battery Charge and Discharge Regulator	FF	Fill Form	RLCL	Retriggerable Latching Current Limiter
BCR	Battery Charge Regulator	GEO	Geostationary Earth Orbit	RS	Radiated Susceptibility
BDR	Battery Discharge Regulator	HPC	High Power Command	S/C	Spacecraft
BOL	Beginning Of Life	HV	High Voltage	S3R	Serial and Sequential Shunt Regulator
CDMU	Central Data Management Unit	I/F	Interface	SA	Solar Array
CE	Conducted Emission	IPD	Internal Protection Diode	SAR	Solar Array Regulator
CM	Command Module	LCL	Latching Current Limiter	SCA	Solar Cell Assembly
CS	Conducted Susceptibility	LEO	Low Earth Orbit	SEE	Single Event Effect
DOD	Depth Of Discharge	LEOP	Low Earth Orbit Phase	SPFF	Single Point Failure Free
DPFF	Dual Point Failure Free	MEA	Main Error Amplifier	SPIS	Spacecraft Plasma Interaction Software
ECSS	European Cooperation for Space Standardisation	MEO	Medium Earth Orbit	SRS	System Requirement Specification
EED	Electro Explosive Device	MRD	Mission Requirement Document	STD	Standard
EEE	Electrical, Electronic, and Electro-mechanical	OBDH	On Board Data Handling	TV	Thermal Vacuum
EMC	Electro Magnetic Compatibility	PCDU	Power Control and Distribution Unit	UM	User Manual
EMCCP	Electro Magnetic Compatibility Control Plan	PD	Power Distribution	UV	Undervoltage
EMI	Electro Magnetic Interference	PEO	Polar Earth Orbit	VFM	Vector Field Magnetometer (SWARM satellite)
EMISM	Electro Magnetic Interference Safety Margin	PTC	Positive Temperature Coefficient (resistor)		
EOL	End Of Life	PVA	Photo Voltaic Assembly		