



Space engineering

Structural factors of safety for spaceflight hardware

Foreword

This Standard is one of the series of ECSS Standards intended to be applied together for the management, engineering, product assurance and sustainability in space projects and applications. ECSS is a cooperative effort of the European Space Agency, national space agencies and European industry associations for the purpose of developing and maintaining common standards. Requirements in this Standard are defined in terms of what shall be accomplished, rather than in terms of how to organize and perform the necessary work. This allows existing organizational structures and methods to be applied where they are effective, and for the structures and methods to evolve as necessary without rewriting the standards.

This Standard has been prepared by the ECSS-E-ST-32-10C Rev.2 Working Group, reviewed by the ECSS Executive Secretariat and approved by the ECSS Technical Authority.

Disclaimer

ECSS does not provide any warranty whatsoever, whether expressed, implied, or statutory, including, but not limited to, any warranty of merchantability or fitness for a particular purpose or any warranty that the contents of the item are error-free. In no respect shall ECSS incur any liability for any damages, including, but not limited to, direct, indirect, special, or consequential damages arising out of, resulting from, or in any way connected to the use of this Standard, whether or not based upon warranty, business agreement, tort, or otherwise; whether or not injury was sustained by persons or property or otherwise; and whether or not loss was sustained from, or arose out of, the results of, the item, or any services that may be provided by ECSS.

Published by: ESA Requirements and Standards Division
ESTEC, P.O. Box 299,
2200 AG Noordwijk
The Netherlands

Copyright: 2019 © by the European Space Agency for the members of ECSS

Change log

| | |
|--|---|
| ECSS-E-ST-32-10A | Never issued |
| ECSS-E-ST-32-10B | Never issued |
| ECSS-E-ST-32-10C 31 July 2008 | First issue |
| ECSS-E-ST-32-10C Rev.1 6 March 2009 | First issue revision 1 |
| ECSS-E-ST-32-10C Rev.2 15 May 2019 | <p>First issue revision 2</p> <p>Changes with respect to ECSS-E-ST-32-01C Rev.1 (6 March 2009) are identified with revision tracking.</p> <p>The changes are based on TA approved Change Requests.</p> <p>Added requirements:</p> <ul style="list-style-type: none">• 4.3.2.1e; 4.3.2.2b. <p>Modified requirements:</p> <ul style="list-style-type: none">• 4.1.2a NOTE moved to end (editorial); 4.3.2.1b, c and d (editorial); Table 4-3; Table 4-4. <p>Editorial corrections:</p> <ul style="list-style-type: none">• Update of Foreword• Nomenclature added• Change of “thermal induced loads” to “thermally induced loads”• Bibliography updated• Interleaved Notes moved to the end of requirement: 4.1.2a; |

Table of contents

| | |
|--|-----------|
| Change log | 3 |
| 1 Scope | 6 |
| 2 Normative references | 8 |
| 3 Terms, definitions and abbreviated terms | 9 |
| 3.1 Terms and definitions | 9 |
| 3.2 Terms specific to the present standard | 9 |
| 3.3 Abbreviated terms..... | 10 |
| 3.4 Nomenclature | 10 |
| 4 Requirements | 12 |
| 4.1 Applicability of structural factors of safety | 12 |
| 4.1.1 Overview..... | 12 |
| 4.1.2 Applicability..... | 12 |
| 4.1.3 General..... | 12 |
| 4.1.4 Design factor for loads | 13 |
| 4.1.5 Additional factors for design | 14 |
| 4.2 Loads and factors relationship | 15 |
| 4.2.1 General..... | 15 |
| 4.2.2 Specific requirements for launch vehicles | 18 |
| 4.3 Factors values | 19 |
| 4.3.1 Test factors | 19 |
| 4.3.2 Factors of safety | 20 |
| Annex A (informative) Qualification test factor for launch vehicles | 25 |
| Bibliography | 27 |
| Figures | |
| Figure 4-1: Logic for Factors of Safety application..... | 17 |
| Figure 4-2: Analysis tree..... | 18 |

Tables

| | |
|---|----|
| Table 4-1: Relationship among (structural) factors of safety, design factors and additional factors | 17 |
| Table 4-2: Test factor values | 19 |
| Table 4-3: Factors of safety for metallic, FRP, sandwich, glass and ceramic structural parts..... | 21 |
| Table 4-4: Factors of safety for joints, inserts and connections..... | 22 |
| Table 4-5: Factors of safety for buckling..... | 23 |
| Table 4-6: Factors of safety for pressurized hardware | 24 |

1 Scope

The purpose of this Standard is to define the Factors Of Safety (FOS), Design Factor and additional factors to be used for the dimensioning and design verification of spaceflight hardware including qualification and acceptance tests.

This standard is not self standing and is used in conjunction with the ECSS-E-ST-32, ECSS-E-ST-32-02 and ECSS-E-ST-33-01 documents.

Following assumptions are made in the document:

- that recognized methodologies are used for the determination of the limit loads, including their scatter, that are applied to the hardware and for the stress analyses;
- that the structural and mechanical system design is amenable to engineering analyses by current state-of-the-art methods and is conforming to standard aerospace industry practices.

Factors of safety are defined to cover chosen load level probability, assumed uncertainty in mechanical properties and manufacturing but not a lack of engineering effort.

The choice of a factor of safety for a program is directly linked to the rationale retained for designing, dimensioning and testing within the program. Therefore, as the development logic and the associated reliability objectives are different for:

- unmanned scientific or commercial satellite,
- expendable launch vehicles,
- man-rated spacecraft, and
- any other unmanned space vehicle (e.g. transfer vehicle, planetary probe)

specific values are presented for each of them.

Factors of safety for re-usable launch vehicles and man-rated commercial spacecraft are not addressed in this document.

For all of these space products, factors of safety are defined hereafter in the document whatever the adopted qualification logic: proto-flight or prototype model.

For pressurized hardware, factors of safety for all loads except internal pressure loads are defined in this standard. Concerning the internal pressure, the factors

of safety for pressurised hardware can be found in ECSS-E-ST-32-02. For loads combination refer to ECSS-E-ST-32-02.

For mechanisms, specific factors of safety associated with yield and ultimate of metallic materials, cable rupture factors of safety, stops/shaft shoulders/recess yield factors of safety and limits for peak Hertzian contact stress are specified in ECSS-E-ST-33-01.

Alternate approach

The factors of safety specified hereafter are applied using a deterministic approach i.e. as generally applied in the Space Industry to achieve the structures standard reliability objectives. Structural safety based on a probabilistic analysis could be an alternate approach but it has to be demonstrated this process achieves the reliability objective specified to the structure. The procedure is approved by the customer.

This standard may be tailored for the specific characteristics and constraints of a space project in conformance with ECSS-S-ST-00.

2

Normative references

The following normative documents contain provisions which, through reference in this text, constitute provisions of this ECSS Standard. For dated references, subsequent amendments to, or revision of any of these publications, do not apply. However, parties to agreements based on this ECSS Standard are encouraged to investigate the possibility of applying the more recent editions of the normative documents indicated below. For undated references, the latest edition of the publication referred to applies.

| | |
|-----------------|--|
| ECSS-S-ST-00-01 | ECSS system – Glossary of terms |
| ECSS-E-ST-10-02 | Space engineering – Verification |
| ECSS-E-ST-10-03 | Space engineering – Testing |
| ECSS-E-ST-32 | Space engineering – Structural general requirements |
| ECSS-E-ST-32-02 | Space engineering – Structural design and verification of pressurized hardware |

Terms, definitions and abbreviated terms

3.1 Terms and definitions

For the purpose of this Standard, the terms and definitions from ECSS-S-ST-00-01, ECSS-E-ST-10-02, ECSS-ST-E-10-03, and ECSS-E-ST-32 apply.

3.2 Terms specific to the present standard

3.2.1 local design factor (K_{LD})

factor used to take into account local discontinuities and applied in series with FOSU or FOSY

3.2.2 margin policy factor (K_{MP})

factor, specific to launch vehicles, which includes the margin policy defined by the project

3.2.3 model factor (K_M)

factor which takes into account the representativity of mathematical models

3.2.4 project factor (K_P)

factor which takes into account at the beginning of the project the maturity of the design and its possible evolution and programmatic margins which cover project uncertainties or some growth potential when required

3.2.5 prototype test

test performed on a separate flight-like structural test article

3.2.6 protoflight test

test performed on a flight hardware

3.2.7 test factors (K_A and K_Q)

factors used to define respectively the acceptance and the qualification test loads

3.2.8 ultimate design factor of safety (FOSU)

multiplying factor applied to the design limit load in order to calculate the design ultimate load

3.2.9 yield design factor of safety (FOSY)

multiplying factor applied to the design limit load in order to calculate the design yield load

3.3 Abbreviated terms

For the purpose of this standard, the abbreviated terms from ECSS-S-ST-00-01 and the following apply.

| Abbreviation | Meaning |
|--------------|---|
| AL | acceptance test load |
| DLL | design limit load |
| DUL | design ultimate load |
| DYL | design yield load |
| FOS | factor of safety |
| FOSU | ultimate design factor of safety |
| FOSY | yield design factor of safety |
| FRP | fibre reinforced plastics |
| GSE | ground support equipment |
| KA | acceptance test factor |
| KQ | qualification test factor |
| LCDA | launch vehicle coupled dynamic analysis |
| LL | limit load |
| N/A | not applicable |
| QL | qualification test load |
| S/C | spacecraft |

3.4 Nomenclature

The following nomenclature applies throughout this document:

- The word “shall” is used in this Standard to express requirements. All the requirements are expressed with the word “shall”.
- The word “should” is used in this Standard to express recommendations. All the recommendations are expressed with the word “should”.

NOTE It is expected that, during tailoring, recommendations in this document are either converted into requirements or tailored out.

- The words “may” and “need not” are used in this Standard to express positive and negative permissions, respectively. All the positive permissions are expressed with the word “may”. All the negative permissions are expressed with the words “need not”.

- d. The word “can” is used in this Standard to express capabilities or possibilities, and therefore, if not accompanied by one of the previous words, it implies descriptive text.

NOTE In ECSS “may” and “can” have completely different meanings: “may” is normative (permission), and “can” is descriptive.

- a. The present and past tenses are used in this Standard to express statements of fact, and therefore they imply descriptive text.

4 Requirements

4.1 Applicability of structural factors of safety

4.1.1 Overview

The purpose of the factors of safety defined in this Standard is to guarantee an adequate level of mechanical reliability for spaceflight hardware.

4.1.2 Applicability

ECSS-E-ST-32-10_0110001

- a. The factors specified in clauses 4.1.4, 4.1.5 and 4.3 shall be applied for:
1. Structural elements of satellites including payloads, equipment and experiments.
 2. The expendable launch vehicles structural elements.
 3. Man-rated spacecraft structures including payloads, equipments and experiments.

NOTE These factors are not applied for the GSE sizing and qualification.

ECSS-E-ST-32-10_0110002

- b. The factors in clauses 4.1.4, 4.1.5 and 4.3 shall be applied for both the design and test phases as defined in Figure 4-1.

4.1.3 General

ECSS-E-ST-32-10_0110003

- a. Design factor and additional factors values shall be agreed with the customer.

4.1.4 Design factor for loads

4.1.4.1 General

ECSS-E-ST-32-10_0110004

- a. For determination of the Design Limit Load (DLL) the Design Factor shall be used, this is defined as the product of the factors defined hereafter.

NOTE Robustness of the sizing process is considered through the Design Limit Loads (DLL).

4.1.4.2 Model factor

ECSS-E-ST-32-10_0110005

- a. A "model Factor" K_M shall be applied to account for uncertainties in mathematical models when predicting dynamic response, loads and evaluating load paths.

NOTE 1 The model factor is applied at every level of the analysis tree system (Figure 4-2) where predictive models are used. It encompasses the lack of confidence in the information provided by the model, e.g. hyperstaticity (uncertainty in the load path because of non accuracy of the mathematical model), junction stiffness uncertainty, non-correlated dynamic behaviour.

NOTE 2 While going through the design refinement loops, K_M can be progressively reduced to 1,0 after demonstration of satisfactory correlation between mathematical models and test measurements.

NOTE 3 For launch vehicles, at system level, K_M is also called "system margin".

ECSS-E-ST-32-10_0110006

- b. K_M value shall be justified.

NOTE Justification can be performed based on relevant historical practice (e.g. typical values of 1,2 are used for satellites at the beginning of new development and 1,0 for internal pressure loads for pressurized hardware), analytical or experimental means.

4.1.4.3 Project factor

ECSS-E-ST-32-10_0110007

- a. A specific "project factor" K_P shall be applied to account for the maturity of the program (e.g. stability of the mass budget, well identified design) and the confidence in the specification given to the project (this factor

integrates a programmatic margin e.g. for growth potential for further developments).

NOTE The value of this factor is generally defined at system level and can be reduced during the development.

ECSS-E-ST-32-10_0110008

- b. K_F value shall be justified.

NOTE Justification can be performed based on relevant historical practice or on foreseen evolutions.

4.1.4.4 Qualification test factor

ECSS-E-ST-32-10_0110009

- a. The qualification factor K_Q shall be applied for satellites.

NOTE For satellites, the qualification loads are part of the specified loads and are accounted for in the dimensioning process. This is different for launch vehicles for which Q_L are consequences of the dimensioning process.

4.1.5 Additional factors for design

4.1.5.1 Overview

All the analysis complexity or inaccuracies and uncertainties not mentioned in clause 4.1.4 are taken into account with the following additional factors.

4.1.5.2 Local design factor

ECSS-E-ST-32-10_0110010

- a. A "local design factor", K_{LD} shall be applied when the sizing approach or the local modelling are complex.

NOTE This factor accounts for specific uncertainties linked to the analysis difficulties or to the lack of reliable dimensioning methodology or criteria where significant stress gradients occur (e.g. geometric singularities, fitting, welding, riveting, bonding, holes, inserts and, for composite, lay-up drop out, sandwich core thickness change, variation of ply consolidation as a result of drape over corners).

ECSS-E-ST-32-10_0110011

- b. K_{LD} values shall be justified.

NOTE 1 Justification can be performed based on relevant historical practice, analytical or experimental means.

NOTE 2 For satellites, a typical value of 1,2 is used in the following cases:

- Composite structures discontinuities;
- Sandwich structures discontinuities (face wrinkling, intracell buckling, honeycomb shear);
- Joints and inserts.

NOTE 3 The use of a local design factor does not preclude appropriate engineering analysis (e.g. K_{LD} does not cover the stress concentration factors) and assessment of all uncertainties.

4.1.5.3 Margin policy factor

ECSS-E-ST-32-10_0110012

- a. A “margin policy” factor K_{MP} shall be applied for launch vehicles.

NOTE This factor, used to give confidence to the design, covers (not exhaustive list):

- the lack of knowledge on the failure modes and associated criteria.
- the lack of knowledge on the effect of interaction of loadings.
- the non-tested zones.

ECSS-E-ST-32-10_0110013

- b. K_{MP} values shall be justified.

NOTE 1 Justification can be performed based on relevant historical practice, analytical or experimental means.

NOTE 2 K_{MP} can have different values according to the structural area they are dedicated to.

4.2 Loads and factors relationship

4.2.1 General

ECSS-E-ST-32-10_0110014

- a. Q_L , A_L , D_{LL} , D_{YL} , and D_{UL} , for the test and the design of satellite, expendable launch vehicles, pressurized hardware and man-rated system shall be calculated from the L_L as specified in Figure 4-1 and Table 4-1.

NOTE 1 As a result of the launch vehicle-satellite coupled dynamic load analysis (LCDA) performed during the project design and verification phases, the knowledge of the LL can be modified during the course of the project, leading to a final estimation of the loads LL_{final} . Then for final verification, it is used as a minimum:

$$QL = KQ \times LL_{final} \quad \text{for qualification, and}$$

$$AL = KA \times LL_{final} \quad \text{for acceptance}$$

NOTE 2 The yield design factor of safety (FOSY) ensures a low probability of yielding during loading at DLL level.

NOTE 3 The ultimate design factor of safety (FOSU) ensures a low probability of failure during loading at DLL level.

ECSS-E-ST-32-10_0110015

- b. The application logic for factors of safety as given in Figure 4-1 shall be applied in a “recursive” manner from system level to subsystem level or lower levels of assembly.

ECSS-E-ST-32-10_0110016

- c. DLL computed at each level shall be used as LL for analysis at their own level to compute the DLL for the next lower levels of assembly.

NOTE This is graphically shown in Figure 4-2.

ECSS-E-ST-32-10_0110017

- d. For satellite, KQ shall be used only at system level in order to avoid repetitive application of qualification margins.

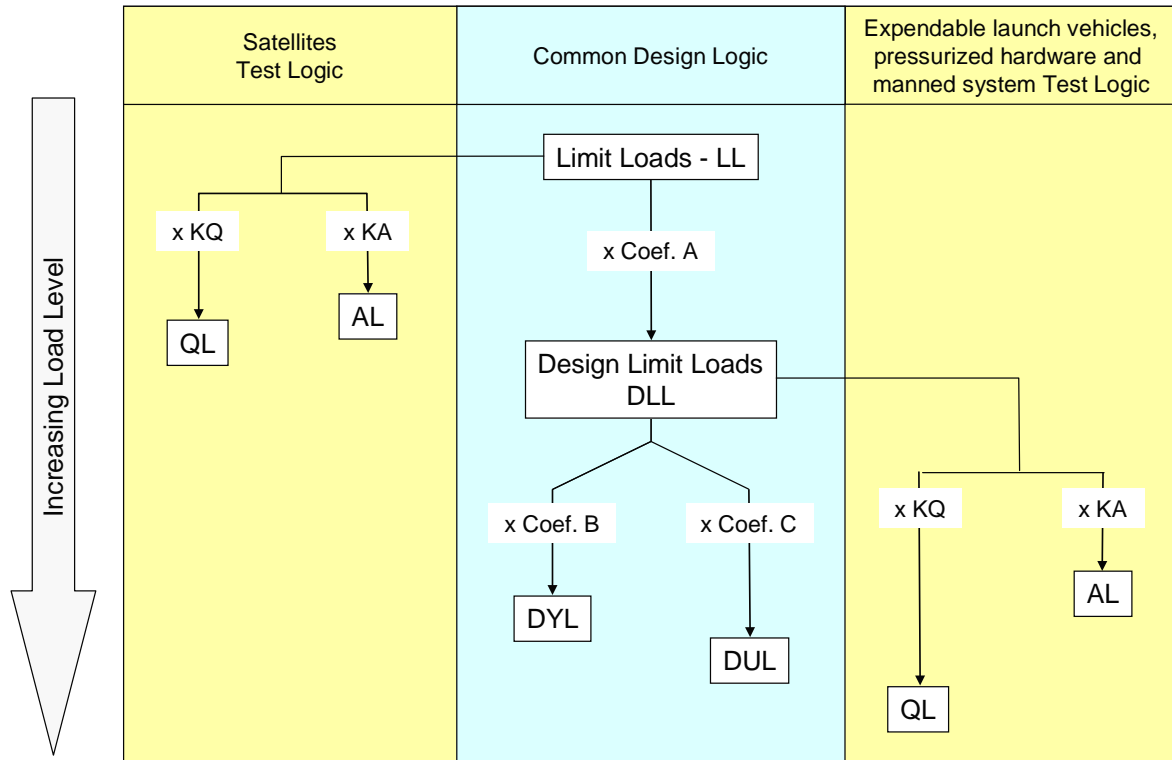

ECSS-E-ST-32-10_0110027

Figure 4-1: Logic for Factors of Safety application

ECSS-E-ST-32-10_0110028

Table 4-1: Relationship among (structural) factors of safety, design factors and additional factors

| Coefficient | Satellite | Launch vehicles and pressurised hardware | Man-rated systems |
|-------------------------------|-----------------------------|--|-----------------------|
| Coef A or Design factor | $K_Q \times K_P \times K_M$ | $K_P \times K_M$ | $K_P \times K_M$ |
| Coef B | $FOS_Y \times K_{LD}$ | $FOS_Y \times K_{MP} \times K_{LD}$ | $FOS_Y \times K_{LD}$ |
| Coef C | $FOS_U \times K_{LD}$ | $FOS_U \times K_{MP} \times K_{LD}$ | $FOS_U \times K_{LD}$ |

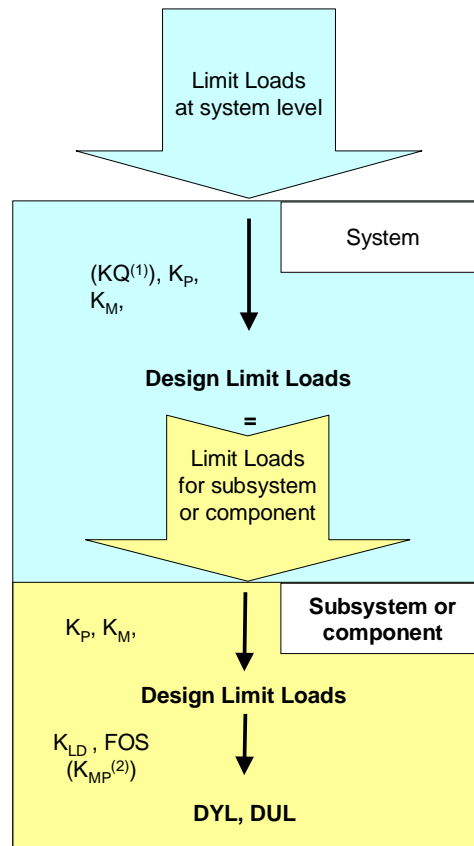

KQ⁽¹⁾: for satellite
K_{MP}⁽²⁾: for launch vehicles

Figure 4-2: Analysis tree

4.2.2 Specific requirements for launch vehicles

ECSS-E-ST-32-10_0110018

- a. The QL shall be defined with a corrected KQ.

NOTE 1 The correction takes into account manufacturing variability and difficulties of having test conditions fully representative of flight conditions.

NOTE 2 The commonly used method for defining the corrected KQ is presented in Annex A for information.

4.3 Factors values

4.3.1 Test factors

ECSS-E-ST-32-10_0110019

- a. The test factors KQ and KA shall be selected from Table 4-2.

ECSS-E-ST-32-10_0110029

Table 4-2: Test factor values

| Load type | Requirements | | | Comments |
|---|--|-----------------------------|--------------|---|
| | Vehicle | KQ | KA | |
| Global flight loads | Satellite | 1,25 ^a | 1 | Typical value to be considered for dimensioning are $J_p=1,05$ to $1,1$ |
| | Launch vehicle | 1,25 ^{corrected b} | 1 or J_p^c | |
| | Man-rated S/C | Launch loads | 1,4 | 1,2 |
| | On orbit loads | 1,5 | | |
| Internal pressure | in conformance with ECSS-E-ST-32-02 ⁱ | | | Applicable for satellite and launch vehicles |
| Dynamic local loads ^d | Satellite | 1,25 ^{a, e} | 1 | |
| | Launch vehicle | 1,25 ^e | N/A | |
| Hoisting loads ^f | Satellite | 2 | N/A | |
| Hoisting loads ^g (fail safe) | Satellite | 1 | N/A | |
| Storage and transportation loads | Satellite | 2 | N/A | |
| | -local transportation and storage loads | | | |
| | -other transportation loads | 1,4 | | |
| Thermal loads ^h | Satellite | 1 | 1 | |
| | Launch vehicle | 1 | 1 | |

a A higher value can be specified by the Launch vehicle Authority or the customer.

b See clause 4.2.2.

c J_p is the proof factor for pressurized structure.

d Local loads are system level loads computed e.g. on units, appendages, equipments, fixtures during dynamic analyses.

e The value applies for qualification tests under local load conditions. A higher value can be specified for specific purposes.

f National laws can specify higher values.

g Fail safe means in case of loss of one of the hoisting slings. In this case, the limit load (LL) is determined by using peak dynamic load due to the failure of the hoisting sling.

h Thermal loads (i.e. mechanical load of thermo elastic origin) are taken with a qualification/acceptance factor equal to 1 by using temperature and gradients levels at qualification/acceptance levels where the qualification/acceptance level temperature includes thermal prediction uncertainty plus a qualification/acceptance temperature margin.

i KQ is defined as "Burst Factor" and KA is defined as "Proof Factor" in ECSS-E-ST-32-02.

4.3.2 Factors of safety

4.3.2.1 Metallic, FRP, sandwich, glass and ceramic structural parts

ECSS-E-ST-32-10_0110020

- a. The factor of safety for metallic, FRP, sandwich, glass and ceramic structural parts shall be selected from Table 4-3.

ECSS-E-ST-32-10_0110021

- b. For satellites and man-rated spacecraft, the factors provided in Table 4-3 shall apply for all additive loads including thermally induced loads.

ECSS-E-ST-32-10_0110022

- c. For satellites and man rated spacecraft, when loads including thermally induced loads are relieving, both FOSU and FOSY shall be 1,0 or less.

NOTE See ECSS-E-ST-32.

ECSS-E-ST-32-10_0110023

- d. For expendable launch vehicles, FOSU and FOSY associated with thermally induced loads shall be 1,0.
- e. For glass and ceramic structural parts the value for the FOSU verification by analysis only shall be agreed between the customer and the developer for each specific application.

NOTE NASA SSP 52005 specifies a figure of 5,0 for unpressurized glass and ceramics parts (analysis only).

Table 4-3: Factors of safety for metallic, FRP, sandwich, glass and ceramic structural parts

| Structure type | Vehicle | Requirements | | | |
|--|-------------------------------------|--------------|-----------------------|------------------------------------|------------------------------------|
| | | FOSY | FOSU | FOSY verification by analysis only | FOSU verification by analysis only |
| Metallic parts | Satellite | 1,1 | 1,25 | 1,25 | 2,0 |
| | Launch vehicle | 1,1 | 1,25 | See Note ^c | 2,0 |
| | Man-rated S/C Launch On Orbit | 1,25 1,1 | 1,4 1,5 | 1,25 ^d | 2,0 2,0 ^d |
| FRP parts (away from discontinuities) | Satellite | N/A | 1,25 | N/A | 2,0 |
| | Launch vehicle | N/A | 1,25 | N/A | 2,0 |
| | Man-rated S/C Launch On Orbit | N/A N/A | 1,5 2,0 | N/A N/A | See Note ^c |
| FRP parts (discontinuities) ^a | Satellite | N/A | 1,25 | N/A | 2,0 |
| | Launch vehicle | N/A | 1,25 | N/A | 2,0 |
| | Man-rated S/C | N/A | 2,0 ^b | N/A | See Note ^c |
| Sandwich parts: - face wrinkling - intracell buckling - honeycomb shear | Satellite | N/A | 1,25 | N/A | 2,0 |
| | Launch vehicle | N/A | 1,25 | N/A | 2,0 |
| | Man-rated S/C | N/A | 1,4 | N/A | See Note ^c |
| Glass and ceramic structural parts | Satellite | N/A | 2,5 | N/A | 5,0 |
| | Launch vehicle | N/A | See Note ^c | N/A | See Note ^c |
| | Man-rated S/C | N/A | 3,0 | N/A | 5,0 ^e |

^a e.g.: holes, frames, reinforcements, steep change of thickness.

^b This value is for consistency with NASA-STD-5001 and already include a KLD factor.

^c No commonly agreed value within the space community can be provided.

^d Values are consistent with NASA SSP 52005 Rev.F, table 5.1.2-1.

^e See requirement 4.3.2.1e: "For glass and ceramic structural parts the value for the FOSU verification by analysis only shall be agreed between the customer and the developer for each specific application."

4.3.2.2 Joints, inserts and connections

ECSS-E-ST-32-10_0110024

- a. The factor of safety for joints, inserts and connections shall be selected from Table 4-4.
- b. For expendable launch vehicles, FOSU and FOSY to failure, gapping and sliding, associated with thermally induced loads shall be 1,0.

ECSS-E-ST-32-10_0110031

Table 4-4: Factors of safety for joints, inserts and connections

| Structure type | Vehicle | Requirements | | | |
|---|-----------------------------|-----------------------|-------------------|------------------------------------|------------------------------------|
| | | FOSY | FOSU | FOSY verification by analysis only | FOSU verification by analysis only |
| Joints and inserts: ^a - Failure - Gapping/Sliding (Safety Critical) ^d - Gapping/Sliding (other) | Satellite | 1,1 | 1,25 | 1,25 | 2,0 |
| | | N/A | | N/A | |
| | | 1,1 | | 2,0 | |
| | Launch vehicle ^e | 1,1 | 1,25 | N/A | N/A |
| | | N/A | | 2,0 | |
| | | 1,1 | | 2,0 | |
| | Man-rated S/C | See Note ^c | 1,4 1,4 1,4 | See Note ^c | See Note ^c |
| | | 1,4 | | 2,0 | |
| | | 1,25 | | 2,0 | |
| Elastomer system and elastomer to structure connection ^b | Satellite | See Note ^c | 2,0 | See Note ^c | See Note ^c |
| | Launch vehicle | See Note ^c | 2,0 | See Note ^c | See Note ^c |
| a These factors are not applied on the bolts preload – see threaded fasteners guidelines handbook (ECSS-E-HB-32-23). b Analysis and test are performed to show that the possible non linear dynamic behaviour of the elastomer does not jeopardize the satellite strength and alignment. c No commonly agreed value within the space community can be provided. d For Safety Critical Structures definition applicable to man rated s/c see NASA SSP 52005 e See requirement 4.3.2.2b: "For expendable launch vehicles, FOSU and FOSY to failure, gapping and sliding, associated with thermally induced loads shall be 1,0." | | | | | |

4.3.2.3 Buckling

ECSS-E-ST-32-10_0110025

- a. The factor of safety for global and local buckling shall be selected from Table 4-5.

NOTE The factor of safety does not cover the knock down factors commonly used in buckling analyses - see Buckling handbook (ECSS-E-HB-32-24).

ECSS-E-ST-32-10_0110032

Table 4-5: Factors of safety for buckling

| Vehicle | Requirements | | | |
|----------------|-----------------------|------|------------------------------------|------------------------------------|
| | FOSY | FOSU | FOSY verification by analysis only | FOSU verification by analysis only |
| Satellite | See Note ^a | 1,25 | See Note ^a | 2,0 |
| Launch vehicle | | | | |
| - Global | N/A | 1,25 | See Note ^a | 2,0 |
| - Local | 1,1 | 1,25 | | 2,0 |
| Man-rated S/C | See Note ^a | 1,4 | See Note ^a | N/A |

a No commonly agreed value within the space community can be provided.

4.3.2.4 Pressurized hardware

ECSS-E-ST-32-10_0110026

- a. The factor of safety for pressurized hardware, engine feeding lines, and tank pressurisation lines shall be selected from Table 4-6 for the mechanical loads except the internal pressure.

NOTE 1 For internal pressure loadings and loads combination, see ECSS-E-ST-32-02.

NOTE 2 Pressurized hardware is defined in ECSS-E-ST-32-02.

Table 4-6: Factors of safety for pressurized hardware

| Vehicle | Requirements | | | |
|--|--------------|------|------------------------------------|------------------------------------|
| | FOSY | FOSU | FOSY verification by analysis only | FOSU verification by analysis only |
| Satellite | 1,1 | 1,25 | See Note ^a | See Note ^a |
| Launch vehicle | 1,1 | 1,25 | See Note ^a | See Note ^a |
| Man-rated S/C | 1,25 | 1,4 | See Note ^a | See Note ^a |
| a No commonly agreed value within the space community can be provided. | | | | |

Annex A (informative)

Qualification test factor for launch vehicles

In European launch vehicle programs, the QL to be implemented during the test is defined with a corrected KQ factor, derived by location and failure mode.

- KQ is modified by correcting factors such as:

$$KQ = (FOSY \times K_{\min} \times K_{\text{adj}} + K_T) \times \frac{1}{K_\theta \times K_\sigma} \text{ for loading at yield load}$$

$$KQ = (FOSU \times K_{\min} \times K_{\text{adj}} + K_T) \times \frac{1}{K_\theta \times K_\sigma} \text{ for loading at ultimate load}$$

- Taking into account the following points:
 - The actual thickness of qualification model versus thickness used for sizing. This is done through the use of the correcting factor K_{\min} which accounts for the effect of the thickness on the structure strength. It corresponds to the ratio of the thickness measured on the test specimen to the dimensioning thickness.
 K_{\min} is only applicable to metal structures, for other structures, $K_{\min}=1.0$ is used.
 - The adjacent structure's influence on the stress field between flight and test conditions. This is done through the use of the correcting factor K_{adj} which accounts for the influence of adjacent structures not present during static tests.
 - If the adjacent flight structures are simulated during static tests, $K_{\text{adj}}=1.0$ is used.
 - Else wise, K_{adj} is deduced as the ratio of the stress state (σ_{flight}) computed in flight configuration to the stress state computed in test configuration (σ_{test}) increased by the overflux factor used for the design.

$$K_{\text{adj}} = \max(1,0, \frac{\sigma_{\text{flight}}}{\sigma_{\text{test}}} \times k_{\text{overflux}})$$

- Effect of thermal gradient stress. This is done through the use of the correcting factor K_T which is defined as the ratio of the increase in the stress due to the local thermal gradient to the stress corresponding to no local thermal gradient.

- The effect of temperature on mechanical characteristics (Young's modulus, strength...). This is done through the use of the correcting factor K_{θ} which is the ratio of the mechanical characteristics considered at flight operating temperature $C_{\theta \text{ flight}}$ to the ones at test temperature $C_{\theta \text{ test}}$.

$$K_{\theta} = \frac{C_{\theta \text{ flight}}}{C_{\theta \text{ test}}}$$

- The influence of A-values for sizing and more probable values for the material constitutive of the qualification model. This is done through the use of the correcting factor K_{σ} . If $f(C_i)$ is the function translating the effect of characteristic C_i on the failure mode, the correcting factor K_{σ} is defined as the ratio of $f(C_i)$ for the characteristic value used for design to $f(C_i)$ for the characteristic value of the tested specimen.

$$K_{\sigma} = \frac{f(C_{i \text{ design}})}{f(C_{i \text{ test}})}$$

If several characteristics C_1, C_2, \dots are affecting the considered failure mode, K_{σ} is defined as:

$$K_{\sigma} = \frac{f(C_{1 \text{ design}})}{f(C_{1 \text{ test}})} \times \frac{f(C_{2 \text{ design}})}{f(C_{2 \text{ test}})} \times \dots \times \frac{f(C_{n \text{ design}})}{f(C_{n \text{ test}})}$$

The correcting factors are defined and agreed with the customer.

Bibliography

| | |
|--|---|
| ECSS-S-ST-00 | ECSS system – Description, implementation and general requirements |
| ECSS-E-HB-32-23 | Space engineering – Threaded fasteners handbook |
| ECSS-E-HB-32-24 | Space engineering – Buckling handbook. |
| NASA-STD-5001 (21 June 1996) | Structural design and test factors of safety for spaceflight hardware |
| NASA SSP 52005 Rev.F (August 2014) | Payload flight equipment requirements and guidelines for safety critical structures |
| A5-SG-1-X-10-ASAI (issue 5.12, April the 8 th ; 2003) | Structure design, dimensioning and test specifications |