



Space product assurance

**Detection of organic contamination
of surfaces by infrared
spectroscopy**

Foreword

This Standard is one of the series of ECSS Standards intended to be applied together for the management, engineering, product assurance and sustainability in space projects and applications. ECSS is a cooperative effort of the European Space Agency, national space agencies and European industry associations for the purpose of developing and maintaining common standards. Requirements in this Standard are defined in terms of what shall be accomplished, rather than in terms of how to organize and perform the necessary work. This allows existing organizational structures and methods to be applied where they are effective, and for the structures and methods to evolve as necessary without rewriting the standards.

This Standard has been prepared by the ECSS Executive Secretariat reviewed and approved by the ECSS Technical Authority.

Disclaimer

ECSS does not provide any warranty whatsoever, whether expressed, implied, or statutory, including, but not limited to, any warranty of merchantability or fitness for a particular purpose or any warranty that the contents of the item are error-free. In no respect shall ECSS incur any liability for any damages, including, but not limited to, direct, indirect, special, or consequential damages arising out of, resulting from, or in any way connected to the use of this Standard, whether or not based upon warranty, business agreement, tort, or otherwise; whether or not injury was sustained by persons or property or otherwise; and whether or not loss was sustained from, or arose out of, the results of, the item, or any services that may be provided by ECSS.

Published by: ESA Requirements and Standards Division
ESTEC, P.O. Box 299,
2200 AG Noordwijk
The Netherlands

Copyright: 2019 © by the European Space Agency for the members of ECSS

Change log

<p>ECSS-Q-70-05A 31 August 2005</p>	<p>First issue Transforming ESA PSS-01-705 into an ECSS Standard</p>
<p>ECSS-Q-70-05B</p>	<p>Never issued</p>
<p>ECSS-Q-ST-70-05C 6 March 2009</p>	<p>Second issue</p>
<p>ECSS-Q-ST-70-05C Rev.1 15 October 2019</p>	<p>Second issue Revision 1 Major changes between ECSS-Q-ST-70-05C (6 March 2009) and this version are:</p> <ul style="list-style-type: none"> • Update of the Standard to include the European Regulation "Registration, Evaluation, Authorisation and Restriction of Chemicals (REACH)" leading to addition of requirements and addition of informative Annex I "REACH exemption documentation" • Implementation of ECSS Change Requests • Update of clause 3.1 "Terms defined in other standards" • Update of clause 3.3 "Abbreviated terms" • Clause 3.4 "Nomenclature" added • Informative Annex I "REACH exemption documentation" added <p><u>Detailed Change Record:</u></p> <p>Added requirements:</p> <ul style="list-style-type: none"> • 5.1.1h. <p>Modified requirements:</p> <ul style="list-style-type: none"> • 5.1.1a (comma added); 5.1.1e.; 5.1.5.1c Note 3; Table 5-1 (Footnote "c" added). Interleaved Notes moved to end of requirement: 5.1.5.2c; 5.1.6a; 5.2.2a; 5.2.3.2a; 5.4.3.2c. <p>Deleted requirements:</p> <ul style="list-style-type: none"> • none <p>Editorial changes:</p> <ul style="list-style-type: none"> • Spelling of term "cleanroom" corrected in document seven times • Interleaved Notes moved to the end of requirement for: 5.1.5.2c; 5.1.6a; 5.2.2a; 5.2.3.2a; 5.4.3.2c.

	<ul style="list-style-type: none">• Table B-2: Footnote “a” added• Annex A.2.2 “Special remarks”: PUID number added to Recommendation and applied correct style.
--	---

Table of contents

Change log	3
Introduction	8
1 Scope	9
2 Normative references	10
3 Terms, definitions and abbreviated terms	11
3.1 Terms defined in other standards	11
3.2 Terms specific to the present standard	11
3.3 Abbreviated terms.....	13
3.4 Nomenclature	14
4 Principles	16
5 Requirements	17
5.1 Preparatory activities	17
5.1.1 Hazard, health and safety precautions	17
5.1.2 Facilities.....	18
5.1.3 Materials	19
5.1.4 Handling.....	19
5.1.5 Equipment.....	19
5.1.6 Miscellaneous items.....	21
5.2 Procedure for sampling and analysis	21
5.2.1 Summary	21
5.2.2 Direct method.....	21
5.2.3 Indirect method	22
5.3 Reporting of calibration and test data.....	26
5.4 Quality assurance.....	26
5.4.1 Data	26
5.4.2 Nonconformance.....	27
5.4.3 Calibration.....	27

5.4.4	Traceability	32
5.4.5	Training.....	32
5.5	Audit of measurement equipment	34
5.5.1	General.....	34
5.5.2	Audit of the system (acceptance)	34
5.5.3	Annual regular review (maintenance) of the system.....	35
5.5.4	Special review.....	35
Annex A (normative) Calibration and test results – DRD.....		36
Annex B (informative) Selection criteria for equipment and accessories for performing the infrared analysis of organic contamination.....		38
Annex C (informative) Calibration of infrared equipment.....		43
Annex D (informative) Interpretation of infrared spectra.....		49
Annex E (informative) The use of molecular witness plates for contamination control.....		54
Annex F (informative) Collecting molecular contamination from surfaces by wiping and rinsing		59
Annex G (informative) Contact test		64
Annex H (informative) Immersion test.....		66
Annex I (informative) REACH exemption documentation.....		68
Bibliography.....		74
 Figures		
Figure 5-1: Sampling and analysis procedure flow chart.....		25
Figure C-1 : Example for a calibration curve.....		47
Figure C-2 : Measurement of peak heights.....		47
Figure D-1 : Characteristic spectrum of bis (2-ethylhexyl) phthalate		50
Figure D-2 : Characteristic spectrum of a long chain aliphatic hydrocarbon.....		50
Figure D-3 : Characteristic spectrum of poly (dimethylsiloxane)		50
Figure D-4 : Characteristic spectrum of poly (methylphenylsiloxane).....		51
Figure E-1 : Witness plate holder and witness plate used for organic contamination control		54
Figure E-2 : Example of a witness plate information sheet		58
Figure F-1 : Example of a sample information form		63

Tables

Table 5-1: Standard materials used for the IR analysis.....	27
Table B-1 : Important properties of common window materials used for infrared spectroscopy	41
Table B-2 : Examples of compound references and suppliers	42
Table C-1 : Volumes to be applied from stock solutions and respective target amounts	46
Table C-2 : Example results of the direct calibration method	47
Table D-1 : Assignment of infrared absorption bands for the four main groups of contaminants.....	51

Introduction

One or more of the following organic substances can contaminate spacecraft materials and hardware, as well as vacuum chambers:

- Volatile condensable products of materials out-gassing under vacuum.
- Volatile condensable products of off-gassing materials.
- Back-streaming products from pumping systems.
- Handling residues (e.g. human grease).
- Residues of cleaning agents.
- Non-filtered external pollution.
- Creep of certain substances (e.g. silicones).

There are several methods for identifying organic species, such as mass spectrometry, gas chromatography and infrared spectroscopy, or a combination of these methods. Infrared spectroscopy, which is the most widely used, is a simple, versatile and rapid technique providing high resolution qualitative and quantitative analyses. The technique is therefore baseline for the present Standard.

1 Scope

This Standard defines test requirements for detecting organic contamination on surfaces using direct and indirect methods with the aid of infrared spectroscopy.

The Standard applies to controlling and detecting organic contamination on all manned and unmanned spacecraft, launchers, payloads, experiments, terrestrial vacuum test facilities, and cleanrooms.

The following test methods are covered:

- Direct sampling of contaminants
- Indirect sampling of contaminants by washing and wiping

Several informative annexes are included to give guidelines to the following subjects:

- Qualitative and quantitative interpretation of spectral data
- Calibration of infrared equipment
- Training of operators
- Use of molecular witness plates
- Collecting molecular contamination
- Contact test to measure the contamination transfer of materials
- Immersion test to measure the extractable contamination potential of materials
- Selection criteria for test equipment

This standard may be tailored for the specific characteristics and constraints of space project in conformance with ECSS-S-ST-00.

2

Normative references

The following normative documents contain provisions which, through reference in this text, constitute provisions of this ECSS Standard. For dated references, subsequent amendments to, or revision of any of these publications do not apply. However, parties to agreements based on this ECSS Standard are encouraged to investigate the possibility of applying the more recent editions of the normative documents indicated below. For undated references, the latest edition of the publication referred to applies.

ECSS-S-ST-00-01	ECSS system – Glossary of terms
ECSS-Q-ST-10	Space product assurance – Product assurance management
ECSS-Q-ST-10-09	Space product assurance – Nonconformance control system
ECSS-Q-ST-20	Space product assurance – Quality assurance
ECSS-Q-ST-70-01	Space product assurance – Contamination and cleanliness control

3

Terms, definitions and abbreviated terms

3.1 Terms defined in other standards

- a. For the purpose of this Standard, the terms and definitions from ECSS-S-ST-00-01 apply, in particular for:
 1. acceptance
 2. analysis
 3. assembly
 4. batch
 5. cleanliness
 6. cleanroom
 7. component
 8. conformance
 9. contaminant
 10. critical
 11. outgassing
 12. qualification
- b. For the purpose of this Standard, the terms and definitions from ECSS-Q-ST-70-01 apply, in particular:
 1. controlled area

3.2 Terms specific to the present standard

3.2.1 absorbance, *A*

logarithm to the base 10 of the reciprocal of the transmittance

[ASTM-E-131]

NOTE The term absorbance is also widely used for the negative log of the ratio of the final to the incident intensities of processes other than

transmission, such as attenuated total reflection and diffuse reflection.

3.2.2 absorption

transfer of infrared energy to the molecules present within the pathway of the radiation

3.2.3 absorptivity

absorbance divided by the product of the concentration of the substance and the sample path length

NOTE 1 Absorptivity = $A/(lC)$, where A is the absorbance, C is the concentration of the substance and l is the sample path length. The unit normally used are cm for l , and kg m^{-3} for C .

NOTE 2 The equivalent IUPAC term is “specific absorption coefficient”.

[adapted from ASTM-E-131]

3.2.4 attenuated total reflection

reflection that occurs when an absorbing coupling mechanism acts in the process of total internal reflection to make the reflectance less than unity

[ASTM-E-131]

3.2.5 diffuse reflection

reflection in which the flux is scattered in many directions by diffusion at or below the surfaces

[ASTM-E-131]

3.2.6 Fourier transformation

mathematical process used to convert an amplitude-time spectrum to an amplitude-frequency spectrum or vice versa

[ASTM-E-131]

3.2.7 infrared spectroscopy

spectroscopy in the infrared region of the electromagnetic spectrum, i.e. with wavelength range from approximately 0,78 μm to 1000 μm (wave number range 12820 cm^{-1} to 10 cm^{-1})

[adapted from ASTM-E-131]

3.2.8 molar absorptivity, ϵ

product of the absorptivity and the molecular weight of the substance

NOTE The equivalent IUPAC term is “molar absorption coefficient”.

[adapted from ASTM-E-131]

3.2.9 radiant power, P

amount of energy transmitted in the form of electromagnetic radiation per unit time

NOTE 1 Unit for radiant power is Watts.

NOTE 2 Radiant power should not be confused with intensity (I), which is the radiant energy emitted within a time period per unit solid angle (measured in Watts per steradian).

3.2.10 reflectance, R

ratio of the radiant power reflected by the sample to the radiant power incident on the sample

[ASTM-E-131]

3.2.11 specific area

diameter of the infrared beam at the window location

NOTE It is expressed as the ratio of the beam diameter over the area. For example, 7 mm/0,38 cm², 10 mm/0,79 cm² or 12 mm/1,13 cm².

3.2.12 transmittance, T

ratio of the radiant power transmitted by the sample to the radiant power incident on the sample

[ASTM-E-131]

3.2.13 wave number, $\bar{\nu}$

number of waves per unit length

NOTE 1 The unit for wave number is cm⁻¹. In terms of this unit, the wave number is the reciprocal of the wavelength, λ (where λ is expressed in cm).

NOTE 2 The wave number is normally used as the X-axis unit of an IR spectrum.

[adapted from ASTM-E-131]

3.3 Abbreviated terms

For the purpose of this Standard, the abbreviated terms from ECSS-S-ST-00-01 and the following apply:

Abbreviation	Meaning
ASTM	American Society for Testing and Materials
ATR	attenuated total reflection
AU	absorbance unit

Abbreviation	Meaning
DOP	dioctylphthalate, synonym bis (2-ethylhexyl) phthalate
DRIFT	diffuse reflection infrared Fourier transform
DTGS	deuterated triglycine sulphate IR detector
ECHA	European Chemicals Agency
ESD	electrostatic discharge
FTIR	Fourier transform infrared (spectrometry)
IES	Institute of Environmental Sciences
IPA	isopropyl alcohol
IR	Infrared
IUPAC	International Union of Pure and Applied Chemistry
ISO	International Organization for Standardization
MCT	mercury cadmium telluride IR detector
NVR	non-volatile residue
PTFE	Polytetrafluoroethylene
QCM	quartz crystal microbalance
REACH	Registration, Evaluation, Authorisation and Restriction of Chemicals (European Regulation)
RI	refractive index
S/N	signal to noise ratio
UV	Ultraviolet
VCM	volatile condensable material

3.4 Nomenclature

The following nomenclature applies throughout this document:

- The word “shall” is used in this Standard to express requirements. All the requirements are expressed with the word “shall”.
- The word “should” is used in this Standard to express recommendations. All the recommendations are expressed with the word “should”.

NOTE It is expected that, during tailoring, recommendations in this document are either converted into requirements or tailored out.

- The words “may” and “need not” are used in this Standard to express positive and negative permissions, respectively. All the positive permissions are expressed with the word “may”. All the negative permissions are expressed with the words “need not”.

- d. The word “can” is used in this Standard to express capabilities or possibilities, and therefore, if not accompanied by one of the previous words, it implies descriptive text.

NOTE In ECSS “may” and “can” have completely different meanings: “may” is normative (permission), and “can” is descriptive.

- e. The present and past tenses are used in this Standard to express statements of fact, and therefore they imply descriptive text.

4 Principles

Infrared qualitative analysis is carried out by functional group identification, or by comparison of the IR absorption spectra of unknown materials with those of known reference materials, or both. It is therefore possible to determine structural information about the molecules of contaminants. In some cases, the source of the contamination can be detected.

Infrared quantitative analysis of levels of contaminants is based on the Lambert-Beer's (henceforth referred to as Beer's) law and requires calibration.

Infrared spectroscopy monitoring is used to verify that the stringent contamination and cleanliness controls applied to spacecraft materials and associated equipment are met. The most common methods for measuring contamination are:

- **Direct methods**
IR-transparent windows used as witness plates (e.g. CaF₂, ZnSe, Ge) are placed in situ, for example, inside a vacuum facility, [cleanroom](#) or spacecraft. Contamination of the windows is then analysed (without further treatment) using an IR spectrophotometer.
- **Indirect methods**
The contaminants on the surface to be tested are collected by means of a concentration technique, for example by washing or wiping a larger surface. Such a surface can also be a witness plate, which is removed after exposure and treated in the same way. The resultant contaminated liquid or tissue is then processed, and finally an IR-transparent or a reflective window containing the contaminants is analysed with the aid of an IR spectrophotometer.

The direct method has demonstrated higher reliability because the sample does not require transfer from the witness plate and therefore reducing the error for quantification. The indirect method allows sample concentration and can therefore provide higher sensitivity.

5 Requirements

5.1 Preparatory activities

5.1.1 Hazard, health and safety precautions

ECSS-Q-ST-70-05_0540001

- a. Unavoidable hazards to personnel, equipment and materials shall be controlled by risk management procedures and kept to a minimum.

ECSS-Q-ST-70-05_0540002

- b. Hazardous substances, items and operations shall be isolated from other activities.

ECSS-Q-ST-70-05_0540003

- c. Items and controls shall be located in order to prevent personnel to be exposed to hazards.

NOTE Typical hazards are electric shock, cutting edges, sharp points, and toxic atmospheres.

ECSS-Q-ST-70-05_0540004

- d. Warning and caution notes shall be included in instructions for operation, storage, transport, testing, assembly, maintenance and repair.

ECSS-Q-ST-70-05_0540005

- e. Hazardous items, equipment or facilities shall be clearly marked to instruct personnel to take the necessary precautions.

ECSS-Q-ST-70-05_0540006

- f. Before starting any operation, safety hazards shall be identified, and the necessary precautions taken to minimize risks.

NOTE For example, use of protection devices when chloroform is used.

ECSS-Q-ST-70-05_0540007

- g. Operations requiring safety suits and protection devices shall be initiated after the personnel involved have the required protection, including any specific protection devices available at the work-place.

ECSS-Q-ST-70-05_0540098

- h. Bis(2-ethylhexyl) phthalate used as reference standard in Table 5-1 shall only be utilised if the specific use has been authorised or it is exempted from authorisation.

NOTE 1 Bis(2-ethylhexyl) phthalate (EC number 204-211-0, CAS number 117-81-7) is on the REACH authorisation list with a sunset date 21st February 2015.

NOTE 2 REACH applies to the European Economic Area.

NOTE 3 The use of DOP for the purpose of this standard is considered exempted from REACH authorisation (see Annex I).

NOTE 4 Other hazardous substances can be affected by the REACH regulation imposing actions for legal compliance or the risk of obsolescence. Background information about the REACH regulation as well as general guidelines to manage obsolescence of Materials, Mechanical Parts and Processes are provided in ECSS-Q-HB-70-23.

5.1.2 Facilities

5.1.2.1 Cleanliness

ECSS-Q-ST-70-05_0540008

- a. The work area shall be clean and free of dust.

ECSS-Q-ST-70-05_0540009

- b. Air used for ventilation shall be filtered to prevent contamination of the work pieces.

5.1.2.2 Environmental conditions

ECSS-Q-ST-70-05_0540010

- a. The ambient conditions for the test, process and work areas shall be
1. Room temperature (22 ± 3) °C and,
 2. Relative humidity (55 ± 10) %.

NOTE Additional conditions can be imposed for critical operations.

5.1.3 Materials

ECSS-Q-ST-70-05_0540011

- a. Materials used in the process shall be stored in a controlled area in conformance with clause 5.1.2.

ECSS-Q-ST-70-05_0540012

- b. Limited-life materials shall be labelled with their shelf lives and dates of manufacture.

5.1.4 Handling

ECSS-Q-ST-70-05_0540013

- a. It shall be demonstrated that no additional contamination is introduced during the handling process.

NOTE 1 Contamination can be avoided by using tweezers and clean gloves, and ensuring that gloves and chemicals are compatible.

NOTE 2 Typically used gloves are of powder-free nylon, nitrile, latex, lint-free cotton.

5.1.5 Equipment

5.1.5.1 Infrared spectrophotometer

ECSS-Q-ST-70-05_0540014

- a. The spectrometer shall have the following specification:
1. Spectral range: At least, $4\,000\text{ cm}^{-1}$ – 600 cm^{-1} ($2,5\ \mu\text{m}$ - $16,7\ \mu\text{m}$).
 2. Resolution: 4 cm^{-1} .
 3. Absorbance of 0,0001 as detection limit for transmission methods.

ECSS-Q-ST-70-05_0540015

- b. Interferences of environmental components shall be eliminated

NOTE Major environmental interferences are caused by H_2O and CO_2 . Elimination of H_2O and CO_2 is possible by flushing with the proper gases or applying a vacuum.

ECSS-Q-ST-70-05_0540016

- c. Plates of infrared-transparent material shall be available.
- NOTE 1 Typical materials are NaCl, MgF₂, CaF₂, ZnSe, or Ge.
- NOTE 2 An ATR-attachment to the spectrophotometer can be used for direct analysis of the surfaces of materials.
- NOTE 3 The results of the ATR infrared spectrophotometer technique are dispersed and can therefore only be used for qualitative purposes.

5.1.5.2 Alignment of the sample holder**ECSS-Q-ST-70-05_0540017**

- a. The sample holder in the sample compartment of the infrared spectrometer shall be aligned for obtaining quantitative information.

ECSS-Q-ST-70-05_0540018

- b. The sample holder shall be aligned so that the infrared beam is positioned in the centre of the IR transparent window.

ECSS-Q-ST-70-05_0540019

- c. For alignment the following steps shall be performed:
1. A mask plate is made with an aperture of (1 – 2) mm diameter.
 2. This mask is placed in the window holder and pointed in the sample compartment of the spectrometer.
 3. The aperture of the instrument is set to 1 mm.
 4. By adjusting the position of the sample holder across the IR beam, the optimum position is determined.
 5. The sample holder is fixed at this position along the line of the IR-beam.
 6. Once the sample holder is aligned, the diameter of the beam is measured.
 7. Step 5.1.5.2c.6 is repeated from bottom, left and right.
 8. A square is formed on the holder, which marks the area where the IR beam passes through without touching the tape.
 9. The size of the square is measured and used in further calculations.

NOTE 1 to item 5: It is important to keep the sample holder at this position because in most equipment the focal point of the IR-beam is set to be in the sample compartment. This means that the beam diameter can be different if this position is changed.

NOTE 2 to item 6: The measurement of the diameter of the beam is performed by masking the window holder, using tape, from the top until the tape absorbs IR light

5.1.6 Miscellaneous items

ECSS-Q-ST-70-05_0540020

- a. The following items shall be used for acquiring and preparing the samples:
1. Pre-cleaned standard filter paper of 70 mm diameter.
 2. Piece of pre-cleaned foam rubber, approximately (50 × 30) mm.
 3. A PTFE film can be used to protect the foam rubber.
 4. Clean, powder-free and lint-free gloves.
 5. Spectral grade solvents.
 6. Petri dishes ranging in diameter from (50 - 70) mm.
 7. Glass rod or micro-syringe.
 8. Glass syringe.
 9. Tweezers.
 10. Infrared lamp.

NOTE 1 to item 1: For orientation on the cleaning process see F.2.3.

NOTE 2 to item 2: See F.2.3.

5.2 Procedure for sampling and analysis

5.2.1 Summary

A summary of the procedures contained in this clause is given in Figure 5-1.

5.2.2 Direct method

ECSS-Q-ST-70-05_0540021

- a. The following steps shall be performed for the determination of organic contamination by the direct method:
1. Position the infrared-transparent windows at or near critical locations.
 2. Verify that the witness plate is subjected to the same conditions that the location to be monitored.
 3. Before installation, record the spectrum of the cleaned, non-exposed window and retain for use as a background measurement.

4. Immediately after exposure, analyse the infrared-transparent windows with the IR spectrophotometer.

NOTE 1 to item 1: For example, inside the compartment, the chamber or the cleanroom to be monitored.

NOTE 2 To item 2: For a representative measurement these conditions are crucial, e.g. identical temperature and pressure.

NOTE 3 to item 4: A waiting period after exposure can cause false results due to creeping of some kinds of contaminants (e.g. silicones).

5.2.3 Indirect method

5.2.3.1 Preparatory activities

ECSS-Q-ST-70-05_0540022

- a. Surfaces shall be washed and wiped with solvents and tissues that are compatible with and do not damage the surface to be analysed.

NOTE 1 For example, solvation and swelling of any material that is not regarded as a contaminant.

NOTE 2 Scratching of the surface.

NOTE 3 IPA and chloroform (CHCl_3) are the most widely used solvents.

5.2.3.2 Washing process

ECSS-Q-ST-70-05_0540023

- a. For the washing process the following steps shall be applied:
 1. Place the contaminated solvent in a Petri dish, and evaporate it in a slightly tilted position with an infrared lamp until only a few droplets remain.
 2. Transfer the droplets to the IR-transparent window.
 3. Position the droplets on the window in an area corresponding to the beam shape of the IR spectrophotometer.
 4. Distribute the contaminant over the area of the IR transparent disk covered by the IR beam.

NOTE 1 to item 2: To avoid contamination and facilitate the work, a glass rod or a micro syringe is normally used for the transfer.

NOTE 2 to item 4: This step is also appropriate for contaminants or substances of low surface tension, which tend to concentrate in small spots (e.g. silicones). Concentration into small

spots can lead to a local saturation of the IR signal and thus to a subsequent underestimation of the overall concentration.

ECSS-Q-ST-70-05_0540024

- b. The window shall then be placed under the IR lamp until the solvent evaporates leaving a thin film of contaminant on the window.

ECSS-Q-ST-70-05_0540025

- c. For quantitative transfer, the transfer process shall be repeated three times.

ECSS-Q-ST-70-05_0540026

- d. Finally, the window shall be fitted to the IR spectrophotometer and aligned such that the beam of the IR spectrophotometer covers the contaminated area of the window

NOTE 1 For details of the alignment process see Annex C.

NOTE 2 For details of the washing process, see Annex F.

5.2.3.3 Wiping process

ECSS-Q-ST-70-05_0540027

- a. The tissue shall be pre-cleaned.

ECSS-Q-ST-70-05_0540028

- b. A blank analysis shall be performed in conformance with 5.2.3.3f and 5.2.3.3g until a background level of less than 5×10^{-7} g for any tissue size is obtained.

NOTE Cleaning can be performed by Soxhlet extraction or immersion in chloroform.

ECSS-Q-ST-70-05_0540029

- c. The cleaned tissue shall be stored/kept in a clean container.

ECSS-Q-ST-70-05_0540030

- d. The surface to be analysed shall be wiped eight times, twice in each of four directions, with either a wet or dry wipe, turning the tissue each time a little after each wiping direction.

ECSS-Q-ST-70-05_0540031

- e. Depending on the chosen type of wiping process (wet or dry), the following steps shall be performed:
1. For a wet wipe process

- (a) Fold with tweezers the pre-cleaned tissue in order to use it as a little "sponge";
 - (b) Wet with spectral grade IPA or chloroform;
 - (c) Hold the folded tissue with curved point tweezers;
 - (d) Store the tissue after wiping, when the solvent is evaporated in the transport container.
2. For a dry wipe process, cover the foam or rubber tube with a standard filter paper and a pre-cleaned tissue.

ECSS-Q-ST-70-05_0540032

- f. The tissue to be analysed shall be immersed for 10 minutes to 15 minutes in a known quantity of spectral grade solvent contained in a Petri dish of 70 mm diameter.

ECSS-Q-ST-70-05_0540033

- g. During the immersion time, the Petri dish shall be covered by a larger Petri dish in order to avoid evaporation of the solvent.

ECSS-Q-ST-70-05_0540034

- h. Handling it with tweezers, the tissue shall be rinsed with 0,5 cm of solvent on each side.

ECSS-Q-ST-70-05_0540035

- i. The Petri dish containing the contaminated solvent shall be processed in conformance with 5.2.3.2.

NOTE For details of the wiping process see Annex F.

Direct method

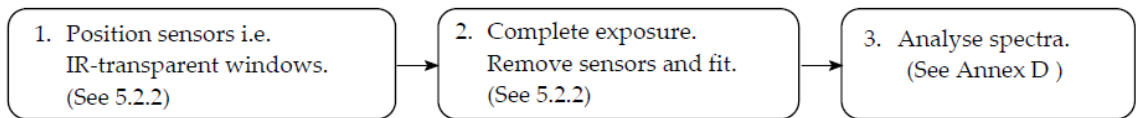

Indirect method

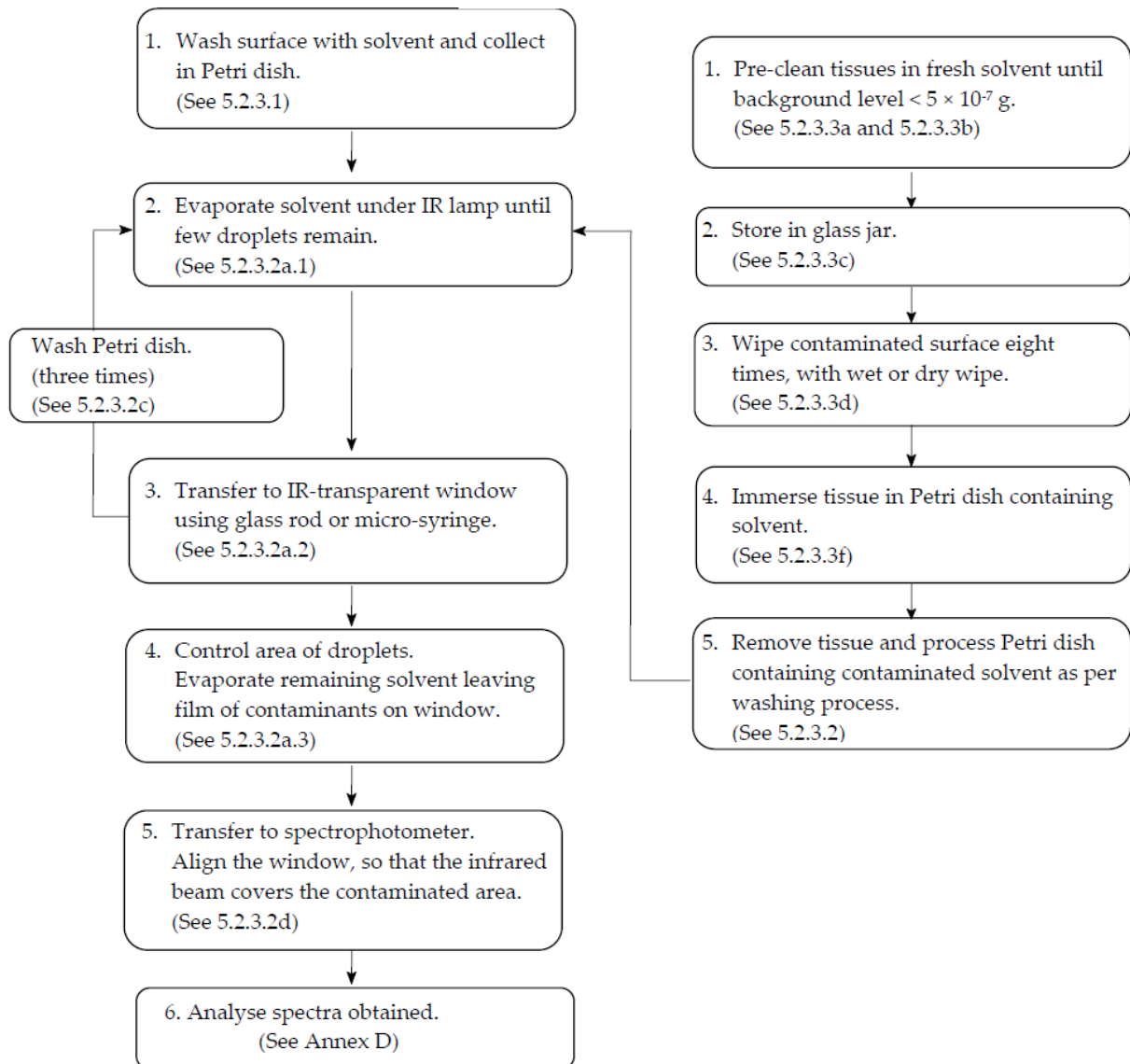

Figure 5-1: Sampling and analysis procedure flow chart

5.3 Reporting of calibration and test data

ECSS-Q-ST-70-05_0540036

- a. Calibration and test data shall be documented in conformance with Annex A – DRD.

ECSS-Q-ST-70-05_0540037

- b. The surface area for the direct methods shall be based on the diameter of the IR beam diameter at the position of the sample window.

ECSS-Q-ST-70-05_0540038

- c. For indirect methods the surface area shall correspond to the surface area washed or wiped.

ECSS-Q-ST-70-05_0540039

- d. For contact or immersion tests, the surface area shall correspond to the contact surface of the sample.

5.4 Quality assurance

5.4.1 Data

ECSS-Q-ST-70-05_0540040

- a. Quality assurance records and log sheets shall be retained for ten years after they have been established.

ECSS-Q-ST-70-05_0540041

- b. Log sheets shall include the following information:
 1. Trade names and batch numbers of the materials under test.
 2. Name of the manufacturer or supplier through whom the purchase was made.
 3. Summary of the preparation and conditioning schedule including the cleaning procedure.
 4. Any noticeable incident observed during the measurement.
 5. The obtained results.

5.4.2 Nonconformance

ECSS-Q-ST-70-05_0540042

- a. Any nonconformance that is observed during the measurement procedure shall be dispositioned in conformance to ECSS-Q-ST-10-09.

5.4.3 Calibration

5.4.3.1 General

ECSS-Q-ST-70-05_0540043

- a. Equipment shall be calibrated for obtaining quantitative information.

NOTE Calibration methods are described in Annex C.3.

ECSS-Q-ST-70-05_0540044

- b. Equipment shall be calibrated after alignment.

ECSS-Q-ST-70-05_0540045

- c. The supplier shall calibrate any measuring equipment to traceable reference standards.

ECSS-Q-ST-70-05_0540046

- d. The supplier shall record any suspected or actual equipment failure as a project nonconformance report in conformance to ECSS-Q-ST-10-09.

NOTE This is to ensure that previous results can be examined to ascertain whether or not re-inspection and retesting is necessary.

ECSS-Q-ST-70-05_0540047

- e. The standard materials used for the IR analysis as described in Table 5-1 shall be used.

ECSS-Q-ST-70-05_0540097

Table 5-1: Standard materials used for the IR analysis

Standard ^a	Chemical nature	Characteristic peaks (cm ⁻¹)
Paraffin oil ^b	Long chain aliphatic hydrocarbon	2920
Bis(2-ethylhexyl) phthalate (DOP) ^c	Aromatic ester	1735
Poly(dimethylsiloxane)	Methyl silicone	1260, 805
Poly(methylphenylsiloxane)	Methyl phenyl silicone	1260, 1120, 805

- ^a Standard materials should be of highest grade available, examples are given in Annex B.3.
- ^b The ratio of peak heights (peak to baseline) between CH₂ (2 925 cm⁻¹) and CH₃ (2 955 cm⁻¹) should be between 0,60 – 0,65.
- ^c [See Annex I for REACH exemption from authorisation.](#)

ECSS-Q-ST-70-05_0540048

- f. If different types of contaminants are frequently found, individual calibration curves for each type of contaminant shall be made upon customer's request.

ECSS-Q-ST-70-05_0540049

- g. The calibration curve that is produced using the direct method shall take into account the transfer efficiency factor when being used for the indirect method.

ECSS-Q-ST-70-05_0540050

- h. The transfer efficiency factor shall be determined by measuring the loss of signal due to the transfer step from the Petri dish to the window.

NOTE For experienced operators, this factor is almost 1, but for less experienced operators it can be significantly less. Operators are for this reason evaluated annually.

ECSS-Q-ST-70-05_0540051

- i. The standards materials used for the calibration lines shall be of high purity.

ECSS-Q-ST-70-05_0540052

- j. Chloroform used shall be of spectroscopic grade, having a non-volatile residue (NVR) < 5 µg/g.

ECSS-Q-ST-70-05_0540053

- k. The absorbance level of the NVR shall be lower than 0,000 1 AU in order to minimize disturbances.

ECSS-Q-ST-70-05_0540054

- l. NVR absorbance shall be determined by evaporating 10 ml of chloroform and recorded by means of IR spectroscopy.

ECSS-Q-ST-70-05_0540055

- m. The standards materials shall be conserved in a cool and dark area and the evaporation of chloroform limited by sealing the measuring flask.

5.4.3.2 Calibration method

ECSS-Q-ST-70-05_0540056

- a. The calibration shall be performed covering the required concentration range.

NOTE Typical range is 5×10^{-8} g/cm² to 5×10^{-6} g/cm².

ECSS-Q-ST-70-05_0540057

- b. Measurements shall be performed by transferring a defined volume from the standard stock solution directly onto the IR-window.

ECSS-Q-ST-70-05_0540058

- c. The following steps shall be followed:
1. The gas-tight syringe is filled with a defined volume from the standard stock solution.
 2. The droplets from the syringe are positioned in the centre of the IR-window, within the area where the IR beam covers the window. The window is placed above a circular mask that corresponds to the size of the IR beam, and viewed from above the window using a magnification device.
 3. The IR-window is positioned in the sample compartment of the spectrometer.
 4. The spectrum is recorded and the transmission loss for the respective standards is measured at the following wave numbers (see also Table 5-1):
 - (a) 2 920 cm⁻¹ for hydrocarbons,
 - (b) 1 735 cm⁻¹ for esters,
 - (c) 1 260 cm⁻¹ or 805 cm⁻¹ for methyl silicone,
 - (d) 1 260 cm⁻¹, 1 120 cm⁻¹ or 790 cm⁻¹ for methyl phenyl silicones.

NOTE 1 to item 1: Example of stock solution range as given in Table C-1.

NOTE 2 to item 1: A typical process for the preparation of standard solutions is described in C.3.2.

ECSS-Q-ST-70-05_0540059

- d. Each point shall be measured at least three times, possibly with different windows in order to eliminate systematic errors.

5.4.3.3 Calibration curve

ECSS-Q-ST-70-05_0540060

- a. The peak quantification shall be performed by measuring peak height or peak area.

NOTE An example of such measurement is given in C.3.3.

ECSS-Q-ST-70-05_0540061

- b. The calibration curve shall have a correlation coefficient higher than 0,98 for six sample points.

NOTE A typical calibration curve is shown in C.3.3.

ECSS-Q-ST-70-05_0540062

- c. The same method of quantification shall be used for the measurement of the contaminant to be analysed.

ECSS-Q-ST-70-05_0540063

- d. The detection limit of the analysis shall be calculated by using the S/N ratio at the specific wave number used for quantification.

ECSS-Q-ST-70-05_0540064

- e. The detection limit of the analysis shall be specified and reported in Mass/specific area.

ECSS-Q-ST-70-05_0540065

- f. For the direct method, the detection limit shall be three times the S/N ratio.

ECSS-Q-ST-70-05_0540066

- g. For the detection limit of the indirect method , the following shall be verified:
1. The surface area of the witness plate or wiped area.
 2. The NVR of the solvents used.
 3. The extractable materials from the tissues used for wiping is less than 5×10^{-7} g.
 4. The precision of the background correction for the NVR of the solvent and the tissue.

5.4.3.4 Calibration results

ECSS-Q-ST-70-05_0540067

- a. Contamination levels shall be expressed in terms of the contribution of the following four main group equivalents: hydrocarbons, esters, methyl silicones, and phenyl silicones.

ECSS-Q-ST-70-05_0540068

- b. The calculation shall be performed using their characteristic group frequencies in conformance with Table 5-1, and the peak maximum of the same vibration mode as for deriving the calibration curve.

NOTE 1 Unless the contaminant matches the calibration standard, quantification is always relative to the reference material and thus semi-quantitative.

NOTE 2 A different chemical environment from a functional group (e.g. substitution, or neighbouring group effects) can lead to shifts in the frequency of the respective vibration modes.

5.4.3.5 Limit of detection

ECSS-Q-ST-70-05_0540069

- a. The noise level of the equipment shall be measured at the wave numbers of the calibration standards (2920 cm^{-1} , 1730 cm^{-1} and 800 cm^{-1}).

ECSS-Q-ST-70-05_0540070

- b. The noise level shall be at least three times less than the signal in order to recognize a signal.

ECSS-Q-ST-70-05_0540071

- c. For indirect methods, the contribution of the following criteria shall be considered:
1. the purity of the solvents,
 2. the cleanliness of wipes,
 3. the transfer efficiency of residue.

ECSS-Q-ST-70-05_0540072

- d. For indirect methods, all solvents used shall have a NVR of less than 5 $\mu\text{g/g}$ and an infrared absorption of the NVR of less than 0,0005 AU ml^{-1} .

NOTE If the rinsing method is used (see Annex D and Annex E), a detection limit in the order of $10^{-8} \text{ g cm}^{-2}$ can be obtained depending on the

surface area analyzed (e.g. for a 15 cm² witness plate).

ECSS-Q-ST-70-05_0540073

- e. For the wiping method, the used tissue shall have a contamination potential of less than 5×10^7 g.

NOTE 1 For description of the wiping method see Annex F.

NOTE 2 With a wiped area of 100 cm², the detection limit of about 2×10^{-8} g cm⁻² can be reached.

5.4.4 Traceability

ECSS-Q-ST-70-05_0540074

- a. For traceability ECSS-Q-ST-20 shall apply.

5.4.5 Training

5.4.5.1 General

ECSS-Q-ST-70-05_0540075

- a. For training ECSS-Q-ST-20 shall apply.

5.4.5.2 Specific training

ECSS-Q-ST-70-05_0540076

- a. Trained and competent personnel shall be employed for all calibration and analysis operations.

ECSS-Q-ST-70-05_0540077

- b. A training programme shall be developed, maintained and implemented.

NOTE The training programme is set up to provide for excellence of workmanship and personnel skills as well as for thorough knowledge of the requirements detailed in this Standard.

ECSS-Q-ST-70-05_0540078

- c. Trained personnel performing calibration and analysis shall be certified.

ECSS-Q-ST-70-05_0540079

- d. The certification of personnel shall be based upon objective evidence of reproducibility and accuracy.

ECSS-Q-ST-70-05_0540080

- e. Personnel shall be retrained or re-assessed annually to maintain the required skills.

ECSS-Q-ST-70-05_0540081

- f. Certification status of personnel shall be recorded and maintained.

5.4.5.3 Training procedures**ECSS-Q-ST-70-05_0540082**

- a. Operators shall be trained by preparing a hydrocarbon standard solution by the following procedure:
1. A gas-tight syringe is filled with the standard solution containing an equivalent of 1×10^{-6} g analyte and put in the Petri dish.
 2. The sample is transferred drop-wise with the glass rod or micro-syringe from the Petri dish onto the IR-window within the area of the IR-beam.
 3. After all droplets are transferred to the window, the Petri dish is washed with a few droplets of fresh chloroform and transferred again according to step 2.
 4. Step 3 is repeated at least twice.
 5. The IR-transparent window is placed on the sample holder in the sample compartment of the pre-aligned spectrometer.
 6. The spectrum is recorded and the transmission loss for hydrocarbons at about 2920 cm^{-1} is measured.
 7. Steps 1 to 6 are repeated 10 times.

ECSS-Q-ST-70-05_0540083

- b. All 10 measurements shall be within 20 % of the average value.

NOTE Experienced operators are able to perform this test within 10 % of the average value.

ECSS-Q-ST-70-05_0540084

- c. Once the positioning or transfer of the solution can be performed within the accepted limits, the trainee operator shall start to produce the calibration curves.

NOTE For the calibration curves see Annex C.3.

5.5 Audit of measurement equipment

5.5.1 General

ECSS-Q-ST-70-05_0540085

- a. The customer shall perform the standard audit in conformance to ECSS-Q-ST-10 clause 5.2.3 "Project PA audits".

NOTE 1 The main purpose of this audit is to ensure the validity of test results by comparison of the test data on identical materials by different test houses.

NOTE 2 The infrared spectra from test houses for the projects of the customer, obtained in the manner laid down in this Standard, are only accepted for the projects of the customer if the test house is certified to perform the relevant procedure in this Standard.

5.5.2 Audit of the system (acceptance)

ECSS-Q-ST-70-05_0540086

- a. The customer's product assurance department shall audit the system after it has been built or purchased.

NOTE The audit is necessary before the system can be accepted for running qualification or quality control tests on materials for use in customer projects.

ECSS-Q-ST-70-05_0540087

- b. The initial audit shall consist of:
1. inspecting the apparatus and associated equipment,
 2. assessing the performance of a test on a defined set of materials,
 3. reporting the non-conformances, and
 4. reporting the audit findings.

ECSS-Q-ST-70-05_0540088

- c. The customer shall issue the certificate of conformance after a successful audit or renew it every three years after a successful audit.

5.5.3 Annual regular review (maintenance) of the system

ECSS-Q-ST-70-05_0540089

- a. The supplier shall perform an annual regular review which consists of:
 - 1. inspecting apparatus and associated equipment,
 - 2. evaluating the mutual comparability (testing),
 - 3. reporting the nonconformances, and
 - 4. reporting the audit findings.

ECSS-Q-ST-70-05_0540090

- b. For each nonconformance the supplier shall perform the following actions:
 - 1. determine the reasons for the nonconformance, and
 - 2. perform a further test in accordance with clause 5.5.2.

NOTE These actions are necessary before a certificate of conformance is renewed.

ECSS-Q-ST-70-05_0540091

- c. The supplier shall deliver the review report to all customers within six weeks after the end of the regular review or evaluation testing.

5.5.4 Special review

ECSS-Q-ST-70-05_0540092

- a. The supplier shall report all modifications of the apparatus or associated equipment.

ECSS-Q-ST-70-05_0540093

- b. The customer shall audit the modifications, if deemed necessary, before utilization of the modified system for the customer's project.

ECSS-Q-ST-70-05_0540094

- c. For major modifications, the supplier shall retest apparatus as described in clause 5.5.2.

Annex A (normative)

Calibration and test results – DRD

A.1 DRD identification

A.1.1 Requirement identification and source document

This DRD is called from ECSS-Q-ST-70-05, requirement 5.3a.

A.1.2 Purpose and objective

The purpose of the document is to present calibration evidences and the analysis results with respect to detected contamination.

A.2 Expected response

A.2.1 Scope and content

<1> Calibration evidences

ECSS-Q-ST-70-05_0540095

- a. The test laboratory shall provide calibration evidence of the quantification method in terms of:
1. date of last calibration,
 2. type and purity of standard materials,
 3. concentration ranges,
 4. detection limits,
 5. correlation coefficients of the calibration curves.

<2> Experiment results

ECSS-Q-ST-70-05_0540096

- a. The results obtained for each experiment shall be reported in terms of equivalent mass per surface area in units of g cm^{-2} for the four main groups:
1. hydrocarbons,
 2. esters,
 3. methyl silicones,
 4. phenyl silicones.

NOTE For each of the four main groups, the mass always corresponds to the type of standard material used for obtaining the calibration curve.

A.2.2 Special remarks

ECSS-Q-ST-70-05_0540099

- a. Spectral interpretation of the contamination is very beneficial for the identification of the potential sources and should be included in the report whenever possible.

Annex B (informative)

Selection criteria for equipment and accessories for performing the infrared analysis of organic contamination

B.1 Infrared spectrometers

B.1.1 General

The different types of infrared spectrometers and accessories used for performing the analysis of organic contamination are described in this Annex.

B.1.2 Dispersive infrared spectrometer

The dispersive infrared spectrometer uses one of the oldest principals in infrared spectroscopy. In dispersive infrared spectrometers, the light coming from the source, a black body emitter (e.g. a Globar), is dispersed by a grating and the energy per wavelength is measured by a detector using a slit.

The advantage of this type of spectrometer is that the sample and reference beam can be measured at the same time with almost no influence of the environment on the spectra.

The disadvantage is the use of a monochromator with slits.

The slit width defines the resolution and the noise on the signal. For a better resolution the slit width can be decreased, but because this means that less light goes through, the signal to noise ratio decreases.

Therefore, there is a trade-off between resolution and signal to noise ratio. Furthermore, the time to acquire a full spectrum can take several minutes (depending on wavelength interval), because each wavelength is measured individually.

This type of infrared spectrometer is now commonly replaced by the Fourier transform infrared spectrometer.

B.1.3 Fourier transform infrared (FTIR) spectrometer

The Fourier transform infrared spectrometer (FTIR) became more feasible with the availability of computers. It works using an interferometer (usually a Michelson interferometer) instead of a monochromator.

The principal is that the IR beam emitted from the source, a black body emitter (e.g. a Globar), is separated by a beam splitter into two paths. One path length is fixed and defined by a standing mirror, and the other is variable and defined by a moving mirror (moving forwards and backwards).

After reflection, the two beams recombine at the beam splitter by undergoing constructive and destructive interference. The resulting modulated signal is directed through the sample compartment to the detector.

The position of the moving mirror is measured by a He-Ne laser. The signal measured by the detector is correlated in time with the position of the mirror. This results in an interferogram with the highest signal intensity in the centre when both mirrors are at an equal distance from the beam splitter.

This interferogram is transformed into a spectrum by a computer using the fast Fourier transformation. One spectrum is produced by one full movement of the mirror. A computer is necessary to collect and transform the data online, and depending on the computational power, several spectra can be recorded per second.

The advantages of this type of spectrometer over the dispersive spectrometer are as follows:

- a. All wavelengths pass through the sample simultaneously, which means that a whole spectrum can be measured quickly in one go.
- b. The noise on the spectrum is reduced by acquiring a larger number of spectra.
- c. The amount of signal going through the sample is not limited by a slit, but is limited by the detector.
- d. The resolution of the spectrum is determined by the path length of the moving mirror.

The disadvantage of the FTIR is that the reference and the sample signal are collected separately. This means that the environment can have a significant influence on the results, e.g. in the region where there is water absorption.

B.1.4 Detectors

In the mid-IR range, two types of detectors are commonly used: the DTGS and the liquid nitrogen cooled MCT.

B.1.4.1. DTGS detector

The DTGS (deuterated triglycine sulphate) is a pyroelectrical detector that generates an electric charge on its surface when the temperature is changed. The scanning speed of this type of detector compared to the MCT detector is slower, however, it has a wider dynamic range. The spectral region depends on

the material of the window used, and corresponds to $9\,000\text{ cm}^{-1}$ - 400 cm^{-1} with KBr.

B.1.4.2. MCT detector

The MCT (mercury cadmium telluride) is a photo-conductive or photovoltaic detector and is based on the semi-conductivity of the materials used. Electrons are released when hit by photons (with energies higher than the respective band gap) and the changes in the conductivity are thus related to the intensity of the received infrared radiation. MCT detectors are cooled with liquid nitrogen.

MCT detectors have a very short response time, but the response is characterized by a gradual increase in response with increasing wavelength followed by a sudden sharp drop.

The other advantage of the MCT compared to the DTGS is the high response to lower light levels. This is the reason why MCT detectors are chosen with reflection units or accessories, because signals with low energy throughput can still be measured.

B.2 Accessories

B.2.1 Transmittance measurements

B.2.1.1. Window materials

For the mid-IR region there does not exist a “perfect” material for windows, and several trade-offs are made in terms of transmittance performance, ease of use and price. The following is a short summary of window materials that are commonly used. Table B-1 summarizes the important properties.

- a. Alkali metal halides (except fluorides): generally water soluble, low RI, and soft. Most commonly NaCl, KBr and CsI.
- b. Metal fluorides: low water solubility, low RI, most commonly CaF_2 , MgF_2 .
- c. Heavy metal halides: silver salts (AgCl , AgBr) are water resistant, transparent over the entire mid-IR, but weak and tend to cold flow. Thallium salts such as KRS-5 have an excellent spectral range and are very robust and have become a commonly used optical material, especially for ATR. The drawback is their high toxicity.
- d. Metal oxides: in general they represent all hard materials with a limited spectral range, e.g. MgO , $\alpha\text{-Al}_2\text{O}_3$, and ZrO_2 .
- e. Group II-IV chalcogenides: the two workhorses, ZnS and ZnSe are mechanically and chemically robust and for many applications (transmittive, ATR) the preferred material.

- f. Groups IV and III-V (diamond family): generally extremely hard and brittle, excellent resistance towards thermal shock. Diamond has superior IR transmittance (except the phonon band around 5 μm) and is most suitable for high-pressure cells. Si and Ge have extremely high RI, making them interesting for ATR applications, however, because of free thermal electrons they become opaque at elevated temperatures.

Table B-1: Important properties of common window materials used for infrared spectroscopy

Material	RI $n_{5\mu\text{m}}$	Wavelength range (μm)	T_{max} ($^{\circ}\text{C}$)	Incompatible with
NaCl	1,52	0,4 – 15	400	Water, glycols, high humidity
KBr	1,54	0,3 – 25	300	Water, alcohols, ether, humidity
CsI	1,74	0,3 – 70	200	Water, alcohols, humidity
CaF ₂	1,40	0,15 – 8	600	Ammonium salts, some concentrated acids
MgF ₂	1,34	0,15 – 8	500	Concentrated acids
AgCl	2,00	0,42 – 27	200	Oxidizers, chelators, concentrated chlorides
AgBr	~2,15	0,5 – 35	200	Oxidizers, chelators, concentrated chlorides
KRS-5	2,38	0,6 – 60	200	Methanol, chelators, strong bases
MgO	1,64	0,4 – 8	> 2 000	Concentrated acids, ammonium salts
⊙-Al ₂ O ₃	1,62	0,15 – 5	1 700	Concentrated acids and bases
ZrO ₂	2,13 ^a	0,36 – 7	> 1 000	HF, H ₂ SO ₄
ZnS	2,25	0,4 – 14	300	Strong oxidizers, some acids
ZnSe	2,43	0,5 – 20	300	Acids, strong concentrated bases
Diamond	2,39	0,22 – 4,3, > 5,4	> 700	Chromosulfuric acid
Si	3,42	1,06 – 6,7, > 30	300	HF + HNO ₃
Ge	4,02	2,0 – 17	100	Hot H ₂ SO ₄ , aqua regia

^a RI at 1 μm

B.2.1.2. Sampling techniques

There are several techniques for sampling gaseous, liquid, and solid materials. For further details refer to the Handbook of vibrational spectroscopy (see Bibliography).

B.2.2 Reflection accessories

There are several reflection techniques, e.g. attenuated total reflection (ATR), diffuse reflectance (DRIFT), grazing angle, integrating spheres, or microscopy. Some of these are also capable of yielding semi-quantitative information. These techniques are based on different theories and use procedures, which are not

within the scope of this Standard. For further details refer to the Handbook of vibrational spectroscopy (see Bibliography).

B.3 Examples of reference compounds for calibration

The compound references and suppliers given in Table B-2 are examples; equivalent or better grades from alternative suppliers can be used.

Table B-2: Examples of compound references and suppliers

Compound	Grade	Supplier
Hydrocarbons	Paraffin liquid for spectroscopy, Ultrasolv [®]	Merck
Esters	bis (2-ethylhexyl)phthalate >98% ^a	Merck
Methyl silicones	poly(dimethyl siloxane), DC 200 [®] fluid, 1000 centistokes	Dow Corning
Methylphenylsilicones	poly(methylphenylsiloxane), DC 710 [®] fluid, 500 centistokes	Dow Corning

^a See Annex I for REACH exemption from authorisation.

Annex C (informative)

Calibration of infrared equipment

C.1 Theory

C.1.1 Lambert-Beer's law

Lambert's law states that for parallel, monochromatic radiation that passes through an absorber of constant concentration, the radiant power decreases logarithmically as the path length increases arithmetically.

Beer's law states that the transmittance of a stable solution is an exponential function of the concentration of the absorbing solute. If both concentration and thickness are variable, the combined Lambert-Beer's law is expressed by equation (C-1):

$$A(\nu) = \varepsilon(\nu)l C \quad (\text{C-1})$$

where

$A(\bar{\nu})$ is the absorbance at wave number $\bar{\nu}$,

$\varepsilon(\bar{\nu})$ is the molar absorptivity at wave number $\bar{\nu}$,

l is the path length,

C is the molar concentration.

To quantify organic contamination, the absorbance is expressed as the mass of a standard material per surface area unit. The trend line is calculated from the calibration curve (see C.3).

Four materials should be used as a standard for the quantification (see Table C-1). These materials are characteristic of the most common contaminants (hydrocarbons, esters, methyl silicones and phenyl silicones).

For contaminants that are unknown but are similar to the standard materials, the relation between the mass and the absorption at a specific wavelength of a standard is used for the quantification. As a result, this method provides the mass of the contaminant in terms of an equivalent amount of the standard material. A method is quantitative, when the contaminant matches the standard materials, otherwise the method is semi-quantitative.

C.1.2 Dependency of equipment and operator

When an infrared-transparent window is used as a witness plate, the measurement is done directly on the window. This method is called the direct method. The amount of organic contamination measured depends on the area analysed, which corresponds to the diameter of the infrared beam.

For the indirect method the operator:

- a. transfers the washed contamination from the Petri dish to the infrared-transparent window, and
- b. positions the solvent containing the contaminants in the area of the infrared beam.

The efficiency of transfer and deposition is dependant on the operator. The training scheme is specified in clause 5.4.5.

C.2 Optimization of equipment

C.2.1 Noise reduction

C.2.1.1. Dispersive infrared

The signal to noise (S/N) ratio for a dispersive instrument is given as a function of the wavelength resolution. Low signal to noise means low resolution. This is due to the use of slits. The resolution is not the most important factor of the analysis and can be set for this type of equipment between 8 cm^{-1} and 16 cm^{-1} .

C.2.1.2. Fourier transform infrared

For FTIR equipment there are several aspects that can influence the S/N ratio. The signal to noise ratio given by the manufacturer is commonly determined at $2\ 100\text{ cm}^{-1}$. This is because the highest energy from the source is in this range and there is no interference of peaks from water vapour.

In most cases, a DTGS detector is favourable for high-energy measurements and it also has a wider dynamic range compared to an MCT.

The S/N is measured over three ranges:

1. $3\ 000\text{ cm}^{-1}$ - $2\ 800\text{ cm}^{-1}$,
2. $1\ 800\text{ cm}^{-1}$ - $1\ 500\text{ cm}^{-1}$,
3. 900 cm^{-1} - 700 cm^{-1} .

These three ranges correspond to lower energy levels. However, the range $3\ 000\text{ cm}^{-1}$ - $2\ 800\text{ cm}^{-1}$ contains peaks from water vapour which results in lower S/N levels than those defined by the manufacturer, but are in this case, more relevant for calculating the detection limits.

For an FTIR spectrometer, a resolution of 4 cm^{-1} is adequate; higher resolution results in more noise. The spectrum is derived from the ratio between a number

of sample scans and a number of background scans. The number of sample scans is usually equal to the number of background scans, but the S/N ratio of the background should not be lower than the one from the signal. The collected spectrum should not be smoothed to get a better S/N ratio.

When optimizing the S/N ratio the following applies:

- a. The optimum mirror speed and zero filling on.
- b. The optimum number of scans. The S/N ratio is improved by a factor of $\sqrt{\text{number of scans}}$. The limit is the stability of the equipment.
- c. The best apodization function and phase correction.
- d. The amount of energy to the detector should be kept below saturation point.
- e. If the energy to the detector is too high, the beam should not be made smaller by adjusting the aperture. This makes the spot on the sample smaller and thus makes it more difficult to position the contamination in the analysing area. Therefore, for example, germanium windows or maze filters are used to receive the optimum energy on the detector.

The manufacturer should be consulted for the optimum settings of the infrared spectrometer. The optimum protocols are stored and used for the actual measurements.

C.3 Calibration

C.3.1 General

The standard materials used for the IR analysis (see Table C-1) are used typically in a laboratory. If different types of contaminants are frequently found, individual calibration curves for each type of contaminant are made.

C.3.2 Preparation of calibration standards

The standards used for the IR-analysis are summarized in Table C-1. A typical process for the preparation of the standard is summarized below:

- a. A high purity reference material is chosen (examples are given in Table C-1).
- b. For the preparation of the stock solution, chloroform of spectroscopic grade, having a non-volatile residue (NVR) $< 5 \mu\text{g/g}$, is used. Before preparing the stock solution, the spectrum of the NVR from 10 ml of chloroform is recorded; the absorbance level is lower than 0,0001 AU.
- c. A stock solution is prepared from the reference standard with the appropriate concentration in chloroform (e.g. 25 mg in 250 ml for $C = 0,1 \text{ g l}^{-1}$). For wider concentration ranges, more than one stock solution can be prepared (e.g. solution A: 12,5 mg in 250 ml for $C = 0,05 \text{ g l}^{-1}$, and solution B: 25 mg in 50 ml for $C = 0,5 \text{ g l}^{-1}$).

- d. The standards are conserved in a cool and dark area and the evaporation of the chloroform is limited by sealing the measuring flask.

NOTE An example of recommended concentration ranges is given in Table C-1.

Table C-1: Volumes to be applied from stock solutions and respective target amounts

Stock solution	Volume (μl)	Target amount (g)
A	1,0	$5,0 \times 10^{-8}$
A	2,5	$1,3 \times 10^{-7}$
A	5,0	$2,5 \times 10^{-7}$
B	1,0	$5,0 \times 10^{-7}$
B	2,5	$1,3 \times 10^{-6}$
B	5,0	$2,5 \times 10^{-6}$
B	10,0	$5,0 \times 10^{-6}$

Alternative calibration methods include the use of an evaporation vacuum chamber containing a quartz crystal microbalance (QCM). The standard material is placed in an electrically heated cell and yields, through a small hole, a homogenous stream of contamination in direct view of a QCM and IR-window.

The QCM measures the contamination on the IR-windows with an accuracy of 10^{-9} g cm⁻². The IR-windows can be directly measured in the FTIR and used for calibration.

This QCM method can have drawbacks due to the differences in the view factor and the differences in the temperatures between the QCM and the IR-transparent window. As the process is performed in a vacuum, re-evaporation can affect the values.

C.3.3 Calibration curve

A graph can be plotted of all the values measured, with the absorbance ($A = \text{Log}(I_0/I)$) of the standard material versus mass. An example of a calibration curve for DOP, on a double logarithmic scale, is shown in Figure C-1.

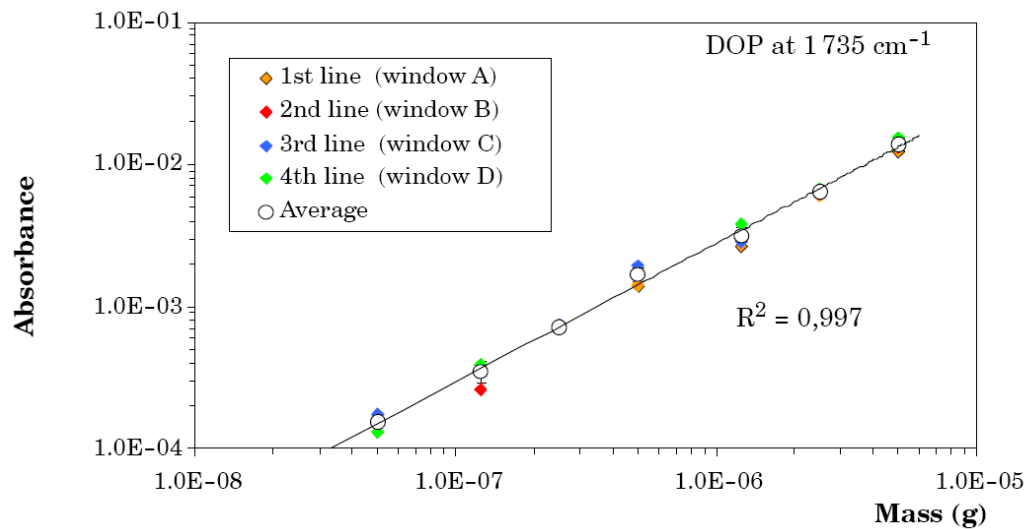

Figure C-1: Example for a calibration curve

It is important that the same method (e.g. peak height or peak area, or setting a base line) is used for the experiment and the calibration.

The best fit (usually a linear line or power curve) through the average points constitutes the calibration curve and can be used for quantification analysis.

The peak height can be measured using the method indicated in Figure C-2. An alternative method is to calculate the corresponding peak area.

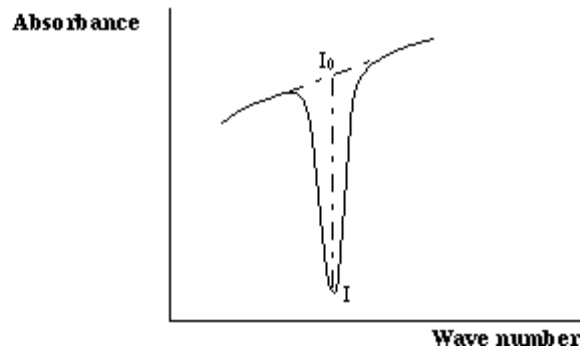

Figure C-2: Measurement of peak heights

As an example, Table C-2 shows the data obtained using the direct calibration method on a system with a beam diameter of 7 mm (0,38 cm²). The peaks at 1260 cm⁻¹ and 1 120 cm⁻¹ were selected, to be used with CaF₂ windows. These calibration lines are examples and are not generally applicable. Individual calibration lines are determined for each spectrometer, transfer process and operator.

Table C-2: Example results of the direct calibration method

Standard	Equation mass (g) =	Noise level (AU)	Detection limit (10 ⁻⁷ g)	Wave number (cm ⁻¹)
Paraffin	$5,55 \times 10^{-4} \times \text{absorbance}^{1,34}$	0,00015	0,1	2920
DOP	$7,72 \times 10^{-4} \times \text{absorbance}^{1,29}$	0,0001	0,1	1735

Standard	Equation mass (g) =	Noise level (AU)	Detection limit (10⁻⁷g)	Wave number (cm⁻¹)
DC 200	$3,66 \times 10^{-4} \times \text{absorbance}^{1,14}$	0,0001	0,2	1260
DC 710	$5,84 \times 10^{-3} \times \text{absorbance}^{1,38}$	0,0001	0,3	1120

Annex D (informative)

Interpretation of infrared spectra

D.1 Qualitative interpretation of spectra

The different types of contamination present can be determined by examining the absorption bands of the spectra obtained from the analyses. Contamination in spacecraft and vacuum chambers commonly comprises mixtures of several contaminants. This makes it more difficult to identify the type and origin of the contamination. The “Micro-VCM” materials screening method (ECSS-Q-ST-70-02) provides infrared spectra of the volatile condensable products released from the materials tested and these can be used as standards in contamination monitoring tests.

Past experience of numerous analyses has indicated that in general the contaminants can be divided into four main groups:

- a. hydrocarbons,
- b. esters,
- c. methyl silicones,
- d. phenyl silicones

See Figure D-1 to Figure D-3 for example spectra for these four main groups. The main IR absorption bands for each group are attributed in Table D-1.

The ester band at about $1\,735\text{ cm}^{-1}$ and the confirmatory bands between $1\,300\text{ cm}^{-1}$ and $1\,100\text{ cm}^{-1}$ indicate the type of ester (aryl or alkyl ester of aromatic or aliphatic acid). For a phthalate ester (mostly used as a plasticizer) the typical bands are the doublet at $1\,600\text{ cm}^{-1}$ and $1\,580\text{ cm}^{-1}$ with intensities of about 1:11 of the $1\,735\text{ cm}^{-1}$ band. For human grease the ester or acid doublet at $1\,735\text{ cm}^{-1}$ and $1\,710\text{ cm}^{-1}$ are typical. Alkyl or aryl esters have also typical bands in the hydrocarbon region as indicated in Table D-1.

Methyl and phenyl silicones have different IR spectra, but both have bands at about 805 cm^{-1} . From the ratio of the bands at $1\,430\text{ cm}^{-1}$ and 790 cm^{-1} , the contribution of the phenyl silicones to the 805 cm^{-1} band can be calculated for defined compounds. Methyl and phenyl silicones generally do not have a band at $2\,925\text{ cm}^{-1}$ or at $1\,735\text{ cm}^{-1}$.

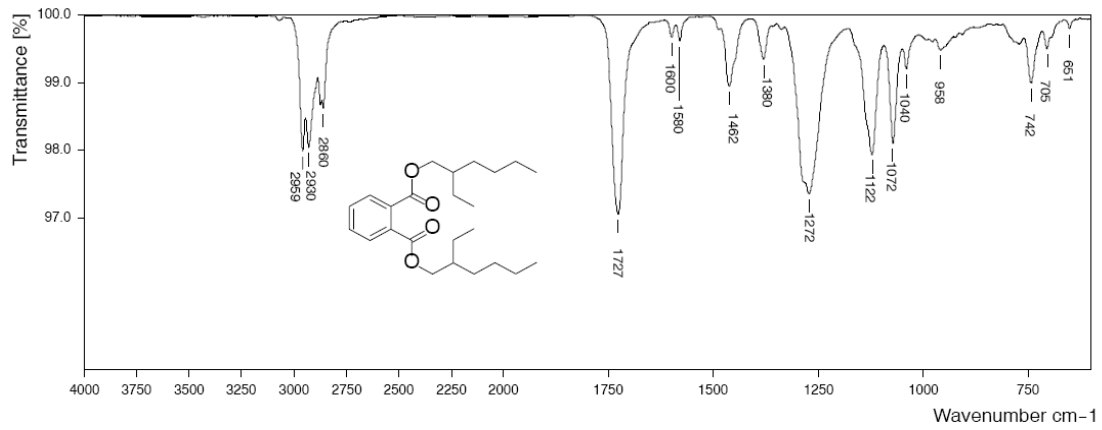

Figure D-1: Characteristic spectrum of bis (2-ethylhexyl) phthalate

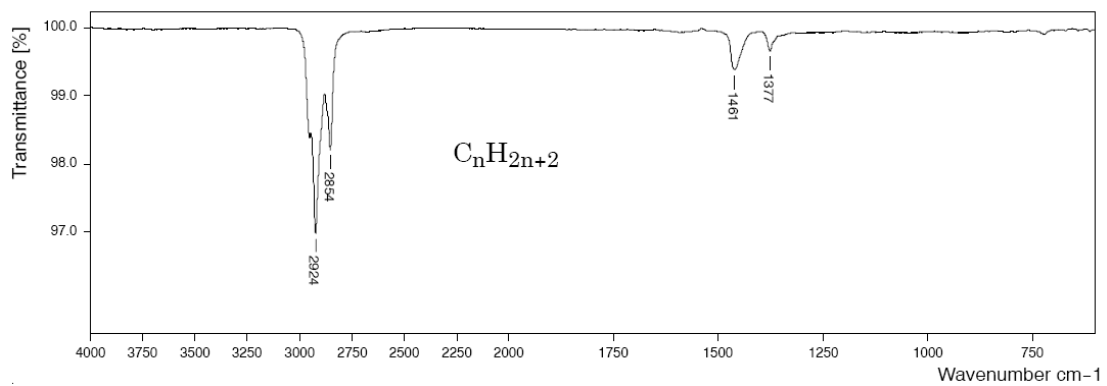

Figure D-2: Characteristic spectrum of a long chain aliphatic hydrocarbon

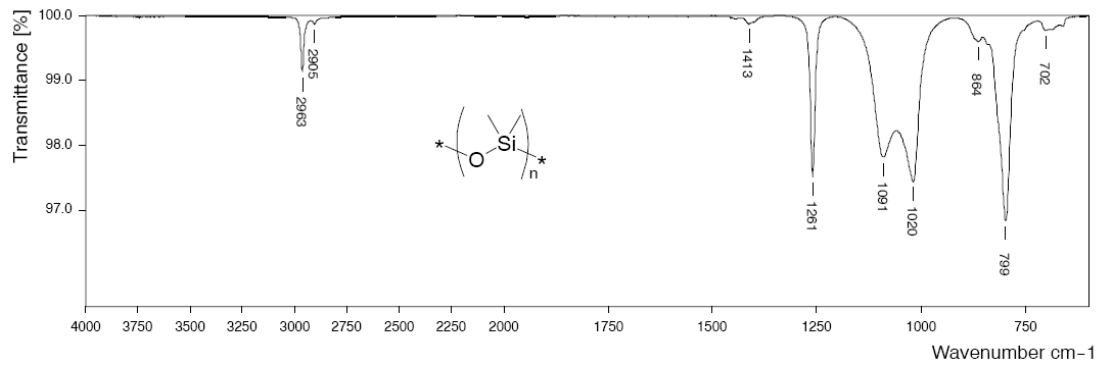

Figure D-3: Characteristic spectrum of poly (dimethylsiloxane)

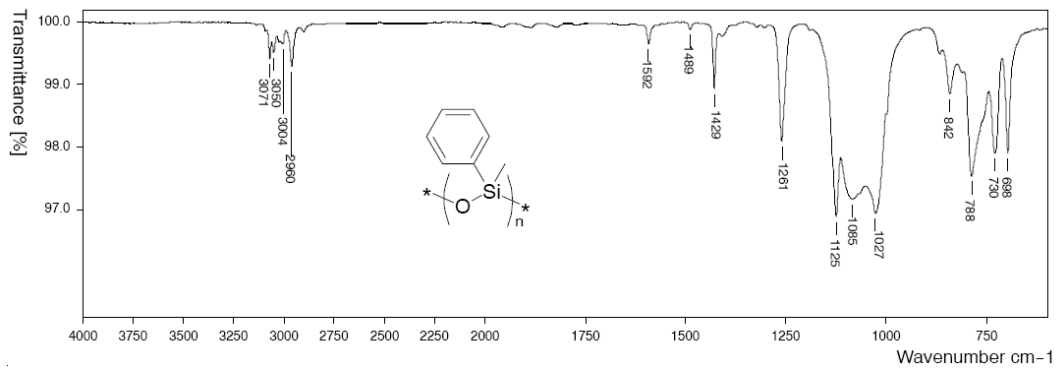

Figure D-4: Characteristic spectrum of poly (methylphenylsiloxane)

Table D-1: Assignment of infrared absorption bands for the four main groups of contaminants

Type of contaminant	Characteristic wave number (cm ⁻¹)	Functional group	Signal strength ^a	Remarks
Hydrocarbons	3 000 - 2 850	Alkanes (CH, CH ₂ , CH ₃)	s	2 or 3 bands, stretching
	3 100 - 3 020	Alkenes	m	Stretching
	1 470 - 1 440	-CH ₃	ms	Asymmetric deformation
	1 390 - 1 370	-CH ₃	m	Symmetric deformation
Esters	1 750 - 1 735	C=O	s	Stretching (saturated ester)
	1 300 - 1 050	C-O	s	Stretching
Methyl silicones	1 280 - 1 255	Si-CH ₃	vs	CH ₃ deformation
	1 130 - 1 000	Si-O-Si	s	Asymmetric stretching
	860 - 760	Si-CH ₃	vs	Si-C stretching or CH ₃ rocking ^b
Methyl phenyl silicones	1 280 - 1 255	Si-CH ₃	vs	CH ₃ deformation
	1 130 - 1 000	Si-O-Si	s	Asymmetric stretching
	1 125 - 1 100	Si-Aryl	vs	
	860 - 760	Si-CH ₃	vs	Si-C stretching or CH ₃ rocking ^b

^a Strength of signal: vs = very strong, s = strong, ms = medium to strong, m = medium.

^b One methyl: 765 cm⁻¹; two methyls: 855 cm⁻¹ and 800 cm⁻¹; three methyls: 840 cm⁻¹ and 765 cm⁻¹.

D.2 Quantitative interpretation of spectra

The quantitative interpretation of IR spectra is not always simple. In some cases, the exact type of contamination is unknown, and insufficient material is available to make a calibration curve.

The quantification in infrared spectroscopy is based on the Lambert Beer's law, in which a relationship is made between the absorbance and the concentration of a compound at a specific wavelength (equation (D-1)).

$$\text{Absorbance} = \log\left(\frac{1}{T}\right) = \log\left(\frac{I_0}{I}\right) = \varepsilon_{\lambda} l C \quad (\text{D-1})$$

where

- T is the transmittance
- I_0 is the intensity of incident light
- I is the intensity of transmitted light
- ε_{λ} is the molar absorption coefficient at a given wavelength ($l \text{ mol}^{-1} \text{ cm}^{-1}$)
- l is the path length (cm)
- C is the molar concentration (mol l^{-1})

To quantify organic contamination, the absorbance is expressed as the mass of a standard material per surface area unit. The trend line (ideally linear) is calculated from the calibration points.

$$\text{Absorbance} = f(\text{Mass}) \approx \text{Constant} \times \text{Mass} \quad (\text{D-2})$$

$$\text{Surface contamination} = \frac{\text{Absorbance}}{\text{Surface area}} \quad (\text{D-3})$$

Calibration curves are derived from pure standard materials characteristic of the four main groups of contaminants (for examples see Figure D-1 to Figure D-4) unless the contaminant matches the calibration standard, quantification is always relative to the reference material and thus semi-quantitative.

Contamination levels are expressed in terms of the presence of the four main groups: hydrocarbons, esters, methyl silicones, and phenyl silicones. Calculations are performed using their characteristic group frequencies (see the detailed procedure in Annex C), whereas the peak maximum of the same vibration mode is selected as used for deriving the calibration curve.

The selected absorbance yields the mass of the contaminant via the calibration curve (equation (D-2)) in units of corresponding grams of the standard material. This is subsequently expressed in terms of mass per surface area unit (equation (D-3)) for the analysed region.

If a new contaminant is encountered, it can be quantified by performing an individual calibration curve (if a standard material is available).

New calibration curves are established for each different spectrophotometer.

For highly outgassing materials, quantitative information can also be obtained from the "Micro-VCM" infrared spectra since the accuracy of the weight of the contamination can be measured to about 10 μg .

D.3 Acceptance criteria

The acceptance criteria are normally defined by the customer. General guidelines for cleanliness and contamination control are given in ECSS-Q-ST-70-01.

Annex E (informative)

The use of molecular witness plates for contamination control

E.1 General

In this Annex, the handling and use of molecular witness plates is described. It is written as a practical guide. The method used to analyse the plates corresponds to the infrared method.

E.2 Design of the witness plates

Stainless steel polished plates can be used to verify the cleanliness level of satellite hardware by being exposed adjacent to it, or they can be used to monitor the deposition of contamination in a test area such as cleanrooms and vacuum chambers.

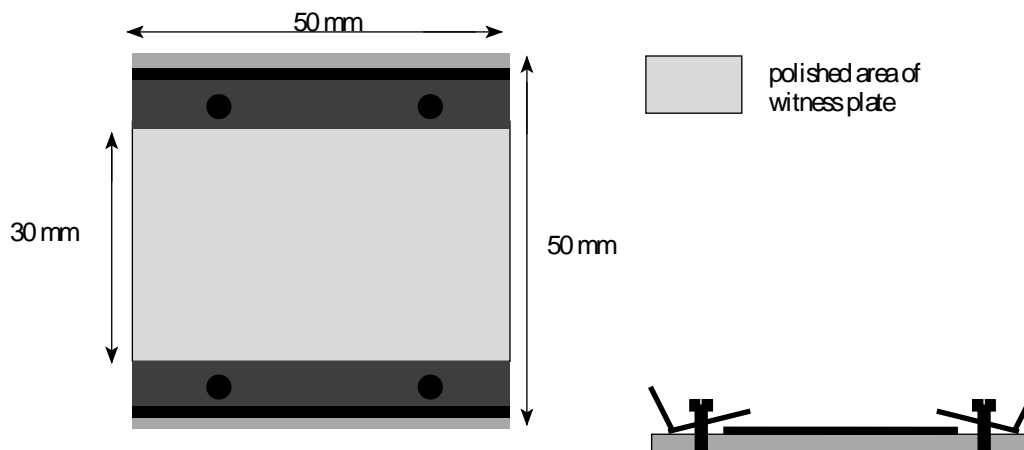

Figure E-1: Witness plate holder and witness plate used for organic contamination control

Use witness plates of (50 × 30) mm (as shown in Figure E-1) for handling, it is fixed onto a stainless steel or aluminium holder of (50 × 50) mm with fixed upstanding bolts that are used for mounting the witness plate.

E.3 Cleaning the witness plates

E.3.1 General

Witness plates are cleaned by the provider of the witness plates.

E.3.2 Materials

- a. Chloroform of spectroscopic grade with NVR < 5 µg/g and stabilized with ethanol.
- b. Glass Syringe: 10 ml, plunger coated with PTFE.
- c. Transport container, preferably metal.
- d. Tweezers.
- e. Solvent resistant clean gloves.
- f. Tissue, cotton, lint free.
- g. Ultrasonic bath.

E.3.3 Procedure

- a. Clean the polished stainless steel witness plate and holder in an ultrasonic bath with a suitable solvent, to remove excessive contamination, and rinsed with de-mineralized water or spectroscopic grade solvents. For low levels of contamination UV-O3 cleaning can be used as an alternative.
- b. Clean the witness plate with a tissue and chloroform.
- c. Handle the witness plate using tweezers and rinsed with chloroform three times using a syringe held at an angle of 60°.
- d. The last droplet of chloroform at the bottom of the plate can be tapped off against the tissue.
- e. Rinse the holder with chloroform in the same way as the witness plate (using tweezers).
- f. Reassemble the holder and witness plate without touching the surface of the polished plate.

E.4 Storage and transport of witness plates

- a. After cleaning, store the witness plates in a pre-cleaned box (e.g. metal).
- b. Ensure that the box does not cause any detectable contamination on the witness plates.
- c. Pack the box in a clean ESD bag. The bag does not contain any volatile organic processing aids, e.g. slipping agents that can cause molecular contamination.

- d. Ensure that the following criteria apply for the packaging:
 1. Absence of organic coating on the inside of the box.
 2. Absence of open holes.
 3. Tightness of the lid.
 4. If it is a lid to be taped, an adhesive tape with low out-gassing values (e.g. polyimide tape with acrylic adhesive) should be used.
 5. The contact surface between the box and the lid is not painted.
 6. The clean bag in which the box is packed is sealed or closed airtight.
- e. Transport the plates at a temperature between 10 °C and 30 °C.
- f. Ensure that the plates are not stored in the vicinity of high out-gassing materials or water.
- g. Ensure that the packaging is opened in a clean environment by qualified personnel.

E.5 Handling of witness plates

- a. Fix the witness plate onto a holder.
- b. Ensure that the surface of the witness plate is not touched and not breathed upon.
- c. Handle the witness plate holder by the upstanding edges with tweezers or with gloves of [cleanroom](#) quality.
- d. Ensure that the witness plate is not used when it is stored, unused, for more than two months, and that after such a period the witness plate is sent back to the supplier.

E.6 Exposure of witness plates

- a. Molecular contaminants consist of organic molecules that are condensable under an ambient environment. When molecules are adsorbed onto a surface, the surface temperature, the environmental pressure, as well as the vapour pressure of the contaminant, influence the time that the molecule is resident on the surface.
- b. To obtain representative results during the exposure experiment, the witness plate is subjected to the same conditions as the hardware.
- c. Witness plates should be placed in, for example, vacuum systems or cleanrooms, at locations around the hardware and near potential sources of contamination, e.g. in the vicinity of soldering or other “dirty” activities.
- d. The cleanliness acceptance levels are defined in ECSS-Q-ST-70-01. For vacuum systems the acceptance limits are given for a representative

blank test over a period of at least 24 hours. The acceptance level for **cleanrooms** is defined after an exposure of one week. For a continuous verification in a **cleanroom**, one of the following exposure sequences can be applied:

- Method 1
 - (a) Two witness plates are placed adjacent to each other at the same location.
 - (b) Plate 1, the (accumulated) witness plate, is the witness for the total exposure time. Plate 2, is replaced weekly (weekly requirements according to ECSS-Q-ST-70-01), every two weeks, or monthly.
 - (c) Plate 2 is analysed to verify the cleanliness for the exposed period (a week, two weeks, month).
 - (d) If contamination is evident from plate 2, then plate 1, the accumulated witness plate, can be analysed to confirm the results of plate 2.
 - (e) If there was no contamination problem during the total exposure time, plate 1 can be analysed to quantify the accumulated contamination levels.
- Method 2
 - (a) Two witness plates are placed adjacent to each other at the same location.
 - (b) One of the witness plates, plate 1, is analysed after exposure for one week and replaced by a new one.
 - (c) The second witness plate, plate 2, is exposed for two weeks, then analysed and replaced by a new witness plate 2.
 - (d) If there is a contamination problem, witness plate 2 can be analysed in order to confirm the results of witness plate 1.
- e. After exposure, the witness plate is packed immediately and sent as soon as possible to the laboratory that performs the analysis. The NVR should be analysed according to this Standard, not later than 4 weeks after the end of the exposure experiment.
- f. When applying long exposure times to witness plates, there is a proportional accumulation of contaminants when the contamination rate is expressed in time units, which are different from the exposure times.

E.7 Witness plate information sheet

A witness plate information sheet should be filled in and a logbook kept for all witness plates that are used for contamination detection. This information sheet is sent with the packed witness plate to the laboratory for analyses. An example of a witness plate information sheet is given in Figure E-2.

Annex F (informative)

Collecting molecular contamination from surfaces by wiping and rinsing

F.1 Introduction

F.1.1 General

Wiping and rinsing is the only method for verifying contamination levels on non-witnessed surfaces. This Annex describes the methods for cleaning, necessary tools, and the wiping and rinsing process.

F.1.2 Wiping methods

There are two wiping methods: a dry and a wet method. The dry wiping method can be used, in most cases, on painted surfaces and on plastic foils. The wet wiping method is only used on surfaces that are compatible with the solvents. Typical solvents are spectroscopic grade IPA or chloroform.

The wiping method can be used to indicate the level of contamination of a specific surface. When comparing the results of measuring contamination from wipes or using witness plates, the witness plates provide, in most cases, more reliable results for the following three reasons:

- a. The transfer of contaminants from the surface using the wiping method is never 100 %. This is especially critical if the contaminants have poor solubility or are cross-linked e.g. by UV-induced deposition.
- b. The wiping method has a higher background signal in FTIR than the witness plate analysis; therefore a surface of about 100 cm² should be wiped (if possible). However, for highly contaminated surfaces it should be taken into account that the large amount of material on the IR-transparent window can lead to a saturation of the signal.
- c. The results of wiping a coated or a plastic surface indicate contamination at that area, including the dissolved surface material.

The higher background signal of the wipes can be corrected by subtracting the spectrum of a blank wipe and from the solvent NVR.

F.1.3 Rinsing method

The rinsing method can only be used when the rinsing solvent can be collected directly or by being absorbed in a clean tissue, and when the surface is compatible to the solvent used.

In most cases the rinsing method has a lower background signal compared to the wiping method. Another advantage of rinsing over wiping is that wiping can damage sensitive surfaces because the surface has been “touched” using some force.

F.2 Preparations

F.2.1 General

The tissues used for wiping are prepared by the tissue provider. The user should not perform any cleaning on the tissue.

F.2.2 Materials for wiping and rinsing

- a. Tweezers: 145 mm curved 45°
- b. Tweezers: 145 mm straight.
- c. Glass Syringe: 10 ml, plunger coated with PTFE (for rinsing and wiping).

NOTE Plastic syringes are not being used because the rubber plunger contains silicone.
- d. Lens tissue, cleaned, e.g. tissue paper for cleaning optical glasses, size 100 mm × 150 mm.
- e. Petri dish: 70 mm diameter (for rinsing).
- f. Glass bottle with lid, cleaned.
- g. Plastic lids often supplied with glass bottles can contain some mould release agent on the surface. If they are not be properly cleaned, it cannot be ensured that cross-contamination is prevented.
- h. Chloroform of spectroscopic grade, NVR < 5 µg/g.
- i. Isopropyl alcohol (2-propanol) of spectroscopic grade, NVR < 5 µg/g.
- j. Acetone of spectroscopic grade, NVR < 5 µg/g.

F.2.3 Cleaning of filter papers, foam rubbers and tissues

The tissues are cleaned as follows:

- a. Cut tissues into the appropriate dimensions for wiping. e.g. pieces of 100 mm × 50 mm.
- b. Place the tissues in a Soxhlet extraction unit.

- c. Perform extraction by using acetone for four hours.
- d. Replace the solvent with chloroform, extract for 12 h, replace with fresh chloroform and extract for another 12 h.
- e. After extraction, analyse a representative tissue according to 5.2.3.3.
- f. If the tissue contains more than 5×10^{-7} g contamination (corrected for solvent background), continue extraction until an acceptable background level is achieved.
- g. Store the cleaned tissues in a special container or directly in a clean glass bottle.

F.2.4 Cleaning of bottles and Petri dish

Glass bottles are cleaned by rinsing the bottle with the appropriate solvents (the final solvent being chloroform) and dried by holding it upside down.

Petri dishes are cleaned in the same way as glass bottles. If the lid is made of polyethylene, the caps can contain a slipping agent used during production. This can be removed with clean isopropyl alcohol and chloroform.

F.2.5 Controlling the quality of the solvent

The quality of the solvent used for cleaning the materials and for the wiping procedure is evaluated as follows:

- a. A known quantity of solvent (e.g. 10 ml) is evaporated and the residue weighed using a micro-balance.
- b. Furthermore, an infrared analysis is performed, conforming to this Standard, to establish the necessary data for spectral corrections.

A quick check of the purity of the solvents can be performed by dripping a few droplets from the filled syringe onto a clean witness plate and visually observing the residue on the surface after evaporation. If the residue is visible to the naked eye, the solvent cannot be used.

NOTE Since contamination levels lower than 10^{-6} g cm⁻² are hardly visible to the naked eye, this visual method can only be performed by experienced people.

F.3 Performing the wipe and rinse method

F.3.1 Wiping method

The wiping method consists of the following steps:

- a. Clean a syringe and two pairs of tweezers with relevant solvents and finally with chloroform before use.

- b. Remove a cleaned tissue from the transport container using the straight tweezers.
- c. Fold the tissue a few times, using both tweezers, until it can be used as a little “sponge”.
- d. Hold the folded tissue with the curved tweezers and wipe the several times in four directions. When performing a wet wipe, the tissue is moistened with the solvent prior to wiping.
- e. After wiping, leave the tissue until all the solvent has evaporated. The tissue is then placed in the glass bottle, the lid closed, the bottle numbered, and the NVR analysed according to this Standard.
- f. The location wiped, the total area, the solvent used, and the type of surface wiped are recorded. See F.4 for a sample information form.

F.3.2 Rinsing method

The rinsing method consists of the following steps:

- a. Clean the Petri dish that is used as the solvent collector and a syringe with the relevant solvents (and finally chloroform).
- b. The surface area to be cleaned can be rinsed gently using the syringe containing the solvent without wetting surrounding areas. The solvent is collected directly in the Petri dish.
- c. Leave the collected solvent in the Petri dish to evaporate and analyse the NVR according to this Standard.
- d. If NVR is part of the test. A second Petri dish containing the residue of a known amount of clean solvent should also be analysed.
- e. The amount of solvent used, the type of solvent, the location that has been rinsed, the type of surface and the area rinsed are recorded. See F.4 for a sample information form.

F.4 Sample information form

When the wiping and rinsing procedures are performed, a record is kept of the sample identification and all the information relevant for the analysis. This information is sent to the laboratory that performs the analysis. An example of a sample information form is given in Figure F-1.

Annex G (informative)

Contact test

G.1 Introduction

The contact test is performed in order to measure the contamination transfer of materials, which can come into contact with spacecraft hardware. Examples of these materials include: packaging materials, shielding materials such as covers and gloves, or materials that are not intended for use under vacuum. The use of the contact test for molecular contamination control is described.

The contact test is also used to verify the contamination transfer from materials, which can come in contact with spacecraft hardware. The samples are placed in direct contact with aluminium foils and compressed with a force of about 100 N cm^{-2} for 1 h, which is comparable to manual pressure.

G.2 Contact test

G.2.1 Materials and equipment

- a. Chloroform of spectroscopic grade, $\text{NVR} < 5 \mu\text{g/g}$.
- b. Glass Syringe: 10 ml, plunger coated with PTFE.
- c. Petri dish: ranging in diameter from 50 mm to 70 mm.
- d. Tweezers.
- e. Aluminium foil: approximately $16 \mu\text{m}$ thick.
- f. Two aluminium plates of at least $100 \text{ mm} \times 100 \text{ mm}$ surface area and 5 mm thickness.
- g. Hydraulic press capable of applying a force of 10 kN.

G.2.2 Procedure

The procedure consists of the following steps:

- a. Cut the aluminium foil into pieces that are the same size as the aluminium plates (about $100 \text{ mm} \times 100 \text{ mm}$).
- b. Cut the sample into pieces of $100 \text{ mm} \times 100 \text{ mm}$. Provide traceability of gloves and bags with inner and outer sides.

NOTE Smaller samples can be used if they are adjusted to ensure that the same pressure is applied.

- c. Clean the aluminium plates with the syringe containing chloroform. The plates are marked as A and B.
- d. Clean the aluminium foils with chloroform until no contamination can be measured using the infrared method. Handle the foils only with tweezers.
- e. Place the aluminium foil with the glossy side up on the aluminium plate A. The glossy side is in contact with the sample.
- f. Place the first sample on the clean aluminium foil. Record the orientation of the sample to this first foil (inner or outer side) side.
- g. On top of the sample, place another clean aluminium foil with the glossy side towards the sample. This results in one sample sandwiched between two aluminium foils.
- h. Place the aluminium plate B on top of the sandwiched sample.
- i. Place the package with the two aluminium plates between the hydraulic press and apply a force that corresponds to a pressure on the sample of 100 N cm^{-2} for 1 h. For example, if the size of the sample is $100 \text{ mm} \times 100 \text{ mm}$, the force is 10 kN.
- j. After 1 h release the pressure and remove the aluminium plate B.
- k. Rinse the side of the aluminium foil that was in contact with the sample with chloroform.
- l. Collect the chloroform in a Petri dish.
- m. Analyse the NVR.

Annex H (informative)

Immersion test

H.1 Introduction

An immersion test consists in measuring the extractable contamination potential of materials that can come in contact with spacecraft hardware

This Annex explains the immersion test in detail. It is performed for measuring the extractable contamination potential of materials that can come into contact with spacecraft hardware. This includes, for example, packaging materials, gloves, shielding materials such as covers, wipes or other cleaning materials, which are not intended to be used under vacuum. The use of the immersion test for molecular contamination control is described.

The immersion test is developed to verify the potential extractable contamination from materials with solvents. The samples are submerged in a NVR solvent for 15 minutes and the extracted contaminants are analysed. The most common NVR solvent is chloroform, however some materials can be chemically attacked by it. The types of contaminants that are expected are, for example, organic antistatic additives, slipping agents, mould release agents, or residual monomers from polymerization processes.

H.2 Immersion test

H.2.1 Materials and equipment

- a. Spectroscopic grade solvent with NVR < 5 µg/g: Examples include chloroform, isopropyl alcohol (IPA), hexane, mixture of 1,1,1-trichloroethane : ethanol = 3:1 (ASTM E 1560).
- b. Glass syringe: 10 ml, plunger coated with PTFE.
- c. Petri dish: ranging in diameter from 50 mm - 70 mm.
- d. Tweezers.

H.2.2 Procedure

The procedure consists of the following steps:

- a. Cut the sample into small parts, for example, thin films to 30 mm × 30 mm, or wires to 30 mm length.
- b. Place the sample into a Petri dish and immerse with 3 ml of NVR solvent.
- c. Cover the Petri dish with a lid for 15 min.
- d. Take the sample out of the solvent and rinse with 1 ml of NVR solvent on both sides.
- e. Analyse the NVR.

NOTE Gravimetric determination of the NVR can be performed if applicable.

Annex I (informative)

REACH exemption documentation

I.1 Introduction

This Annex provides the exemption documentation for the use of bis (2-ethylhexyl) phthalate (EC number 204-211-0, CAS number 117-81-7) within the scope of this standard, according to REACH Articles 56(3)1 and 3(23) “use in Scientific Research and Development”.

The purpose of this documentation is to detail and confirm the requirements for the exemption from REACH authorisation under Title VII of Regulation (EC) No 1907/2006 of the European Parliament and of the Council of 18 December 2006 concerning the Registration, Evaluation, Authorisation and Restriction of Chemicals (REACH) for the substance use(s) specified herein. The documentation can be used to show compliance with the REACH authorisation provisions, in relation to the use described, to REACH competent authorities and other third parties.

I.2 Scope of exemption justification

I.2.1 Overview

The purpose of this Annex is to define the scope of the exemption documentation in terms of substance, use and legal entity(ies) (downstream user(s)).

I.2.2 Substance

Substance name:	Bis(2-ethylhexyl) phthalate (SEHP), synonym dioctylphthalate (DOP)
EC Number:	204-211-0
CAS Number:	117-81-7
Intrinsic property(ies) from REACH authorisation list:	Toxic for reproduction (category 1B)
Sunset date:	21 st February 2015

I.2.3 Description of uses

The Substance is used as a reference standard material for detection of organic contamination on surfaces by infrared spectroscopy. This method is used to verify that the stringent contamination and cleanliness control requirements applied to spacecraft materials and associated equipment are met.

The Standard prescribes exclusively laboratory use of the substance in minute quantities for establishing a calibration line for quantification of molecular contamination levels of surfaces. The use of the substance as a standard material is mandatory according to clause 5.4.3.1 and Table 5-1.

I.2.4 Legal entity(ies)

This documentation covers the described use of the mentioned Substance(s) by legal entities based in the European Economic Area using the Substance according to the Standard. Entities wishing to rely on this documentation are reminded to follow the safety instructions in the supplier's safety data sheet and any applicable local rules and guidelines in their country.

I.3 Exemption clause

According to REACH Article 56(3)1 an exemption from the authorisation requirement applies to the use of substances in scientific research and development (SRD), i.e. any scientific experimentation, analysis or chemical research carried out under controlled conditions in a volume less than one tonne per year; (REACH Article 3(23)).

The terms "scientific experimentation, analysis or chemical research" and "under controlled conditions" are not further defined in the REACH legal text, and therefore require further interpretation.

I.4 Fulfilment of exemption conditions

I.4.1 Overview

The fulfilment of exemption conditions is based on a comparison of the actual use patterns with the legal terms as interpreted by ECHA and national competent authorities. Based on these interpretations the fulfilment of the exemption conditions is detailed hereafter for REACH Article 3(23).

I.4.2 Interpretation: Any scientific experimentation, analysis or chemical research

I.4.2.1. Analytical activities such as monitoring and quality control.

For example routine quality control or release tests in laboratory scale using the substance as extraction solvent or analytical standard.

The substance is used as analytical standard for detection of organic contamination of surfaces by infrared spectroscopy according to the ECSS standard ECSS-Q-ST-70-05. The Standard prescribes exclusively laboratory use of the substance in minute quantities for establishing a calibration line for quantification of molecular contamination levels of surfaces. The use of the substance as a standard material is mandatory according to clause 5.4.3.1 and Table 5-1, as the material is characteristic of the most common organic esters (see Annex C.1.1).

I.4.3 Interpretation: Carried out under controlled conditions

I.4.3.1. Explicit requirements set out by the competent authorities

No explicit requirements are identified.

I.4.3.2. Applicable EU, national, regional or local legislation on environmental protection or health and safety at work that the use is compliant with

Entities wishing to rely on this documentation are reminded to follow the safety instructions in the supplier's safety data sheet and any applicable local rules and guidelines.

I.4.3.3. Intrinsic Annex XIV property(ies)

The Substance is included in Annex XIV because it is classified as toxic for reproduction (category 1B), i.e. because it is hazardous for human health. It has also been identified on the candidate list for the additional reasons of being of equivalent level of concern due to its endocrine disrupting properties (Article 57 f – environment and human health).

I.4.3.4. Handling steps (technological processes)

This can include activities such as change of drums, testing of materials compatibility, loading, off-loading, cleaning/decontamination of equipment, waste treatment, and disposal. Please recall the REACH definition of "use" of a substance meaning "any processing, formulation, consumption, storage, keeping, treatment, filling into containers, transfer from one container to

another, mixing, production of an article or any other utilisation" (REACH Article 3(24)).

It is mainly the transfer of a small amount (as below) into a flask and dilution with a solvent. The most practical approach is to do that by weight, i.e. the operator puts about 25 mg of DOP with a Pasteur pipette into the flask. The actual concentration of the solution is calculated from the actual mass rather than trying to get exactly 25 mg. Key handling steps include:

- Preparation of calibration standard according to Annex C.3.2. A typical solution contains 25 mg of the Substance in 250 mL chloroform. From there 1-10 µL are taken with a gas-tight syringe for measurement.
- Transfer of calibration standard onto IR transparent window according to clause 5.4.3 of the ECSS-Q-ST-70-05, the transfer of the above solution via syringe is described in detail under 5.4.3.2c of the ECSS-Q-ST-70-05.
- A calibration curve contains 5 different concentrations at minimum, each in triplicate so 15 times syringe transfer from solution to IR transparent window.
- The windows are re-usable, i.e. the DOP is rinsed with a solvent into a waste container.

I.4.3.5. Containment of the substance during use

The following containment devices are used (in chronological order) to contain the Substance during use and thus prevent/minimize exposure of workers and the environment:

- The bottle containing DOP is kept closed until transferred, once the right amount of DOP is in the flask both can be closed and transferred again.
- It is important to perform the dissolution of the DOP with solvent in a fume hood, as far as required by local rules and guidelines. The same applies to the transfer of the droplets onto the window.

Furthermore, the Standard prescribes:

- in requirement 5.1.1b that "*Hazardous substances (such as the Substance), items and operations shall be isolated from other activities*".
- in requirement 5.1.3a that "*Materials used in the process shall be stored in a controlled area*". Requirement 5.4.3.1m further provides that "*The standard materials (such as the Substance) shall be conserved in a cool and dark area and the evaporation of chloroform limited by sealing the measuring flask*".

I.4.3.6. Exposure control

The procedure is intended for calibration of an analytical method and thereby already at the level of trace amounts. Residual exposure to operators can be minimised by performing the application of the calibration solution onto the window in a fume hood. Environmental exposure is controlled by usage of waste containers for chemicals.

I.4.3.7. Personal Protective Equipment (PPE)

The following requirements prescribe that:

- Requirement 5.1.1f *“Before starting any operation, safety hazards shall be identified, and the necessary precautions taken to minimize risks, for example use of protection devices when chloroform is used”*.
- Requirement 5.1.1g *“Operations requiring safety suits and protection devices shall be initiated after the personnel involved have the required protection, including any specific protection devices available at work-place”*.

Examples of PPE used during Substance handling include: standard good laboratory practice is applied

I.4.3.8. Special procedures applied before cleaning and maintenance

Not applicable: The life-cycle is application, measurement and cleaning.

I.4.3.9. Other risk management standards (if any)

The following requirements describe hazard, health and safety precautions:

- Requirement 5.1.1a: *“Unavoidable hazards to personnel, equipment and materials shall be controlled by risk management procedures and kept to a minimum”*.
- Requirement 5.1.1c: *“Items and controls shall be located in order to prevent personnel to be exposed to hazards”*.
- Requirement 5.1.1e: *“Hazardous items, equipment or facilities shall be clearly marked to instruct personnel to take the necessary precautions”*.

Cleanliness requirements are set out in clause 5.1.2.1.

Quality assurance records and log sheets shall be retained for ten years. The log sheets shall include among others (see clause 5.4.1):

- *“Trade names and batch numbers of the materials under test*
- *Name of the manufacturer or suppliers through whom the purchase was made*
- *Summary of the preparation and conditioning schedule including the cleaning procedure”*.

Training (clause 5.4.5)

- *“Trained and competent personnel shall be employed for all calibration and analysis operations.*
- *A training programme shall be developed, maintained and implemented.*
- *Trained personnel performing calibration and analysis shall be certified”*.

Users are required to comply with the safety instructions in the REACH safety data sheets provided by the Substance supplier.

I.4.4 Interpretation: In a volume less than one tonne per year

I.4.4.1. Per substance per legal entity (sum up volumes of multiple use sites, laboratories or analyses within the same entity)

About 30 mg/year, if the guidelines of ECSS are followed. A maximum of few 100 mg/year can be possible, if different flask volumes and dilution series are used.

I.5 Conclusion

The use of the given Substance in accordance with ECSS-Q-ST-70-05 and its clause 4 in particular is exempted from REACH authorisation according to REACH Articles 56(3)1 and 3(23).

Entities wishing to rely on this documentation are reminded to follow the safety instructions in the supplier's safety data sheet and any applicable local rules and guidelines in their country.

It is important to update the REACH exemption documentation in case of relevant revisions of ECSS-Q-ST-70-05.

Bibliography

- | | |
|-----------------|--|
| ECSS-S-ST-00 | ECSS system – Description, implementation and general requirements |
| ECSS-Q-ST-70-02 | Space product assurance – Thermal vacuum outgassing test for the screening of space materials |
| ASTM E 131 | Standard terminology relating to molecular spectroscopy |
| ASTM E 1560 | Standard test method for gravimetric determination of non-volatile residue from cleanroom wipers |
- Handbook of Vibrational Spectroscopy; Chalmers, J.M., Griffiths, P.R., Eds.; John Wiley & Sons Ltd., Chichester, UK, 2002
- Analytical Chemistry Handbook, J.A. Dean; McGraw-Hill, New York, USA, 1995