



Space engineering

Electromagnetic compatibility

This draft is distributed to the ECSS community for Public Review.

NOTE: Only the modified parts are subject of the Review. Comments to not modified parts will be treated as new Change Requests.

(Duration: 8 weeks)

Start of Public Review: 19 March 2021

End of Public Review: 14 May 2021

DISCLAIMER (for drafts)

This document is an ECSS Draft Standard. It is subject to change without any notice and may not be referred to as an ECSS Standard until published as such.

**ECSS Secretariat
ESA-ESTEC
Requirements & Standards Division
Noordwijk, The Netherlands**

Foreword

This Standard is one of the series of ECSS Standards intended to be applied together for the management, engineering, product assurance and sustainability in space projects and applications. ECSS is a cooperative effort of the European Space Agency, national space agencies and European industry associations for the purpose of developing and maintaining common standards. Requirements in this Standard are defined in terms of what shall be accomplished, rather than in terms of how to organize and perform the necessary work. This allows existing organizational structures and methods to be applied where they are effective, and for the structures and methods to evolve as necessary without rewriting the standards.

This Standard has been prepared by the ECSS-E-ST-20-07C Rev. 2 Working Group, reviewed by the ECSS Executive Secretariat and approved by the ECSS Technical Authority.

Disclaimer

ECSS does not provide any warranty whatsoever, whether expressed, implied, or statutory, including, but not limited to, any warranty of merchantability or fitness for a particular purpose or any warranty that the contents of the item are error-free. In no respect shall ECSS incur any liability for any damages, including, but not limited to, direct, indirect, special, or consequential damages arising out of, resulting from, or in any way connected to the use of this Standard, whether or not based upon warranty, business agreement, tort, or otherwise; whether or not injury was sustained by persons or property or otherwise; and whether or not loss was sustained from, or arose out of, the results of, the item, or any services that may be provided by ECSS.

Published by: ESA Requirements and Standards [Section](#)
ESTEC, P.O. Box 299,
2200 AG Noordwijk
The Netherlands

Copyright: [2021](#)© by the European Space Agency for the members of ECSS

Change log

Change log for Draft development	
Previous Steps	
ECSS-E-ST-20-07C- Rev.2draft1(27February2020)+PUID _LT_19_November_2020.docx	Updated draft from L. Trougnou.
ECSS-E-ST-20-07C Rev. 2 Draft 1 19 November 2020	ES edit of WG Draft from 19 Nov 2020 Editorial changes with impact marked with Comments.
ECSS-E-ST-20-07C- Rev.2draft1(27February2020)+PUID_LT_ 12_February_2021	Draft for Review (DFR) submitted to ES
ECSS-E-ST-20-07C Rev.2-DIR1 26 February 2021	Parallel Assessment 5-19 March 2021
Current step	
ECSS-E-ST-20-07C Rev.2-DIR1 26 February 2021	Public Review 19 March – 14 May 2021
Next Steps	
DIR + impl. DRRs	Draft with implemented DRRs
DIR + impl. DRRs	DRR Feedback
DIA	TA Vote for publication
DIA	Preparation of document for publication (including DOORS transfer for Standards)
	Publication
Change log for published Standard (to be updated by ES before publication)	
ECSS-E-ST-20-07A	Never issued
ECSS-E-ST-20-07B	Never issued
ECSS-E-ST-20-07C 31 July 2008	First issue

ECSS-E-ST-20-07C Rev. 1 7 February 2012	First issue Revision 1
ECSS-E-ST-20-07C Rev.2-DIR1 26 February 2021	<p>First issue Revision 1</p> <p>Changes with respect to ECSS-E-ST-20-07C Rev. 1 (7 February 2012) are identified with revision tracking.</p> <p>Overview of changes:</p> <ul style="list-style-type: none">• _____ <p>Added requirements:</p> <ul style="list-style-type: none">• _____ <p>Modified requirements:</p> <ul style="list-style-type: none">• _____ <p>Deleted requirements:</p> <ul style="list-style-type: none">• _____ <p>Editorial changes:</p> <ul style="list-style-type: none">• _____

Table of contents

Change log	3
Introduction	10
1 Scope	11
2 Normative references	12
3 Terms, definitions and abbreviated terms	13
3.1 Terms from other standards.....	13
3.2 Terms specific to the present standard	14
3.3 Abbreviated terms.....	16
4 Requirements	18
4.1 General system requirements	18
4.2 Detailed system requirements	18
4.2.1 Overview.....	18
4.2.2 EMC with the launch system	18
4.2.3 Lightning environment.....	19
4.2.4 Spacecraft charging and effects	19
4.2.5 Spacecraft DC magnetic emission	20
4.2.6 Radiofrequency compatibility	21
4.2.7 Hazards of electromagnetic radiation	21
4.2.8 Intrasystem EMC	22
4.2.9 EMC with ground equipment	22
4.2.10 Grounding	22
4.2.11 Electrical bonding requirements	23
4.2.12 Shielding (excepted wires and cables)	25
4.2.13 Wiring (including wires and cables shielding)	25
5 Verification	28
5.1 Overview	28
5.1.1 Introduction	28
5.1.2 Electromagnetic effects verification plan	28
5.1.3 Electromagnetic effects verification report.....	28
5.2 Test conditions	28
5.2.1 Measurement tolerances.....	28

5.2.2	Test site	29
5.2.3	Ground plane	31
5.2.4	Power source impedance.....	32
5.2.5	General test precautions	34
5.2.6	EUT test configurations.....	35
5.2.7	Operation of EUT	39
5.2.8	Use of measurement equipment	40
5.2.9	Emission testing.....	42
5.2.10	Susceptibility testing.....	44
5.2.11	Calibration of measuring equipment.....	47
5.2.12	Power bus voltage.....	48
5.2.13	Photographic data	48
5.3	System level	49
5.3.1	General	49
5.3.2	Safety margin demonstration for critical or EED circuits	49
5.3.3	EMC with the launch system	49
5.3.4	Lightning	50
5.3.5	Spacecraft and static charging	50
5.3.6	Spacecraft DC magnetic field emission	50
5.3.7	Intra–system electromagnetic compatibility	51
5.3.8	Radiofrequency compatibility	51
5.3.9	Grounding	51
5.3.10	Electrical bonding.....	51
5.3.11	Wiring and shielding.....	52
5.4	Equipment and subsystem level test procedures	52
5.4.1	Overview	52
5.4.2	CE, power leads, differential mode, 30 Hz to 100 kHz.....	52
5.4.3	CE, power and signal leads, 50 kHz to 100 MHz.....	55
5.4.4	CE, power leads, inrush current	58
5.4.5	DC Magnetic field emission, magnetic moment.....	61
5.4.6	RE, electric field, 30 MHz to 18 GHz	64
5.4.7	CS, power leads, 30 Hz to 100 kHz.....	69
5.4.8	CS, bulk cable injection, 50 kHz to 100 MHz.....	72
5.4.9	CS, power leads, transients	76
5.4.10	RS, magnetic field, 30 Hz to 100 kHz.....	80
5.4.11	RS, electric field, 30 MHz to 18 GHz	83
5.4.12	Susceptibility to wire-coupled electrostatic discharges (legacy method).....	91

5.4.13	Susceptibility to wire-coupled electrostatic discharges (current injection probe method).....	97
5.4.14	Susceptibility to electrostatic discharges into the chassis	100
5.4.15	CE, power leads, time domain	104

Annex A (informative) Subsystem and equipment limits..... 107

A.1	Overview	107
A.2	CE on power leads, differential mode, 30 Hz to 100 MHz	107
A.3	CE on power leads, in-rush currents	109
A.4	CE on power and signal leads, common mode, 100 kHz to 100 MHz	109
A.5	<<deleted>>	110
A.6	DC magnetic field emission	110
A.6.1	General	110
A.6.2	Characterization	110
A.6.3	Limit	111
A.7	RE, low-frequency magnetic field.....	111
A.8	RE, low-frequency electric field.....	111
A.9	RE, electric field, 30 MHz to 18 GHz.....	112
A.10	CS, power leads, differential mode, 30 Hz to 100 kHz	112
A.11	CS, power and signal leads, common mode, 50 kHz to 100 MHz	113
A.12	CS, power leads, short spike transients	114
A.13	RS, magnetic field, 30 Hz to 100 kHz.....	115
A.14	RS, electric field, 30 MHz to 18 GHz.....	116
A.15	Susceptibility to electrostatic discharge.....	117

Figures

Figure 4-1: Bonding requirements	24
Figure 5-1: RF absorber loading diagram	30
Figure 5-2: Line impedance stabilization network schematic	33
Figure 5-3: General test setup	35
Figure 5-4: Typical calibration fixture	41
Figure 5-5: Conducted emission, 30 Hz to 100 kHz, measurement system check	54
Figure 5-6: Conducted emission, 30 Hz to 100 kHz, measurement setup.....	55
Figure 5-7: Conducted emission, measurement system check	56
Figure 5-8: Conducted emission, measurement setup in differential mode	56
Figure 5-9: Conducted emission, measurement setup in common mode.....	57
Figure 5-10: Inrush current: measurement system check setup.....	59
Figure 5-11: Inrush current: measurement setup	59

Figure 5-12: Smooth deperm procedure	64
Figure 5-13: Electric field radiated emission. Basic test setup	66
Figure 5-14: Electric field radiated emission. Antenna positioning	67
Figure 5-15: Electric field radiated emission – Multiple antenna positions	67
Figure 5-16: CS, power leads, measurement system check set-up	70
Figure 5-17: CS, power leads, signal injection	71
Figure 5-18: Bulk cable injection, calibration set-up	75
Figure 5-19: Signal test waveform	75
Figure 5-20: CS, power and signal leads, bulk cable injection	76
Figure 5-21: CS, power leads, differential mode transients, calibration setup	77
Figure 5-22: CS, power leads, differential mode transients, injection setup	78
Figure 5-23: <<deleted>>	78
Figure 5-24: CS, power leads, common mode transients, calibration setup	79
Figure 5-25: CS, power leads, common mode transients, probe injection setup	79
Figure 5-26: Measurement system check configuration of the radiating system	81
Figure 5-27: Basic test setup	82
Figure 5-28: <<deleted>>	86
Figure 5-29: Example of electric field calibration test setup	87
Figure 5-30: RS Electric field – Multiple test antenna positions	88
Figure 5-31: <<deleted>>	88
Figure 5-32: Spacecraft charging ESD susceptibility test	93
Figure 5-33: Susceptibility to ESD: calibration configuration	94
Figure 5-34: Susceptibility to ESD: test equipment configuration	95
Figure 5-35: Example of compliant discharge current shape	96
Figure 5-36: Test setup for calibration of test waveform	98
Figure 5-37: Typical ESD pulse measured during calibration (3 A/div, 4 ns/div)	99
Figure 5-38: Wire-coupled ESD test setup (current injection probe method)	99
Figure 5-39: Discharge current verification setup	102
Figure 5-40: Ideal contact discharge current waveform at 8 kV	103
Figure 5-41: Conducted emission, power leads, time domain: measurement setup	105
Figure A-1 : Power leads, differential mode conducted emission limit ...	108
Figure A-2 : Common mode conducted emission limit	110
Figure A-3 : Radiated electric field limit	112
Figure A-4 : Conducted susceptibility limit, frequency domain	113

Figure A-5 : Calibration level at the measurement port of the calibration fixture 114

Figure A-6 : CS, voltage spike in percentage of test bus voltage 115

Figure A-7 : Radiated susceptibility limit 116

Tables

Table 5-1: Absorption at normal incidence.....30

Table 5-2: Bandwidth and measurement time42

Table 5-3: Maximum step sizes for susceptibility tests.....46

Table 5-4: Correspondence between test procedures and limits52

Table A-1 : Equipment: susceptibility to conducted interference, test signal 114

Introduction

Electromagnetic compatibility (EMC) of a space system or equipment is the ability to function satisfactorily in its electromagnetic environment without introducing intolerable electromagnetic disturbances to anything in that environment.

The space system is designed to be compatible with its external natural, induced, or man-made electromagnetic environment. Natural components are lightning for launchers, the terrestrial magnetic field for space vehicles. Spacecraft charging is defined as voltage building-up of a space vehicle or spacecraft units when immersed in plasma. Electrostatic discharges result from spacecraft charging with possible detrimental effects. External man-made interference, intentional or not, are caused by radar or telecommunication beams during ground operations and the launching sequence. Intersystem EMC also applies between the launcher and its payload or between space vehicles.

Intrasystem EMC is defined between all electrical, electronic, electromagnetic, and electromechanical equipment within the space vehicle and by the presence of its self-induced electromagnetic environment. It comprises the intentional radiated electromagnetic fields and parasitic emission from on-board equipment. Both conducted and radiated emissions are concerned. An electromagnetic interference safety margin is defined at system critical points by comparison of noise level and susceptibility at these points.

1 Scope

EMC policy and general system requirements are specified in ECSS-E-ST-20.

This ECSS-E-ST-20-07 Standard addresses detailed system requirements (Clause 4), general test conditions, verification requirements at system level, and test methods at subsystem and equipment level (Clause 5) as well as informative limits (5.4.14.4d.6).

Associated to this standard is ECSS-E-ST-20-06 “Spacecraft charging”, which addresses charging control and risks arising from environmental and vehicle-induced spacecraft charging when ECSS-E-ST-20-07 addresses electromagnetic effects of electrostatic discharges.

Annexes A to C of ECSS-E-ST-20 document EMC activities related to ECSS-E-ST-20-07: the EMC Control Plan (Annex A) defines the approach, methods, procedures, resources, and organization, the Electromagnetic Effects Verification Plan (Annex B) defines and specifies the verification processes, analyses and tests, and the Electromagnetic Effects Verification Report (Annex C) document verification results. The EMEVP and the EMEVR are the vehicles for tailoring this standard.

This standard may be tailored for the specific characteristic and constrains of a space project in conformance with ECSS-S-ST-00-02.

2**Normative references**

The following normative documents contain provisions which, through reference in this text, constitute provisions of this ECSS Standard. For dated references, subsequent amendments to, or revision of any of these publications do not apply, However, parties to agreements based on this ECSS Standard are encouraged to investigate the possibility of applying the more recent editions of the normative documents indicated below. For undated references, the latest edition of the publication referred to applies.

ECSS-S-ST-00-01	ECSS system - Glossary of terms
ECSS-E-ST-20	Space engineering - Electrical and electronic
ECSS-E-ST-20-06	Space engineering - Spacecraft charging
ECSS-E-ST-33-11	Space engineering - Explosive systems and devices
ECSS-E-ST-50-14	Space engineering – Spacecraft discrete interfaces
IEC 61000-4-2 (Edition 1.2)	Electromagnetic compatibility (EMC) - Part 4-2: Testing and measurement techniques - Electrostatic discharge immunity test

Terms, definitions and abbreviated terms

3.1 Terms from other standards

For the purpose of this Standard, the terms and definitions from ECSS-S-ST-00-01 apply, in particular for the following terms:

- critical item**
- customer**
- equipment**
- item**
- launcher, launch vehicle**
- mission**
- requirement**
- safety critical function**
- supplier**
- spacecraft, space vehicle**
- subsystem**
- system**
- test**
- verification**

For the purposes of this Standard, the following terms have a specific definition contained in ECSS-E-ST-20:

- conducted emission**
- electromagnetic compatibility**
- electromagnetic compatibility control**
- electromagnetic interference**
- electromagnetic interference safety margin**
- emission**
- high-voltage**
- lightning indirect effects**
- radiated emission**
- radiofrequency**
- susceptibility**

susceptibility threshold

For the purposes of this document, the following terms have a specific definition contained in ECSS-E-ST-20-06:

electrostatic discharge (ESD)

secondary arc

For the purposes of this document, the following term has a specific definition contained in ECSS-E-ST-33-11:

electro-explosive device (EED)

3.2 Terms specific to the present standard

3.2.1 ambient level

level of radiated and conducted signal, and noise that exist at the specified test location and time when the equipment under test is not operating

NOTE E.g. atmospherics, interference from other sources, and circuit noise or other interference generated within the measuring set compose the “ambient level”.

3.2.2 antenna factor

factor that, when properly applied to the voltage at the input terminals of the measuring instrument, yields the electric or magnetic field strength

NOTE 1 This factor includes the effects of antenna effective length, mismatch, and transmission losses.

NOTE 2 The electric field strength is normally expressed in V/m and the magnetic field strength in A/m or T.

3.2.3 common mode voltage

voltage difference between source and receiver ground references

3.2.4 contact discharge method

method of testing in which the electrode of the high-voltage test generator is held in contact with the discharge circuit, and the discharge actuated by a discharge switch

3.2.5 electromagnetic environmental effects

impact of the electromagnetic environment upon equipment, systems, and platforms

NOTE It encompasses all electromagnetic disciplines, including electromagnetic compatibility; electromagnetic interference, electromagnetic vulnerability, hazards of electromagnetic radiation

to personnel, electro-explosive devices, volatile materials, and natural phenomena effects.

3.2.6 field strength

resultant of the radiation, induction and quasi-static components of the electric or magnetic field

NOTE The term “electric field strength” or “magnetic field strength” is used, according to whether the resultant, electric or magnetic field, respectively, is measured.

3.2.7 ground plane

metal sheet or plate used as a common reference point for circuit returns and electrical or signal potentials

3.2.8 improper response

subsystem or equipment response which can be either inadvertent or unacceptable

3.2.9 inadvertent response

proper subsystem functional response (within normal range of limits) actuated by electromagnetic interference, but occurring at other than the normal operational cycle, which in turn causes improper response to the total space system

3.2.10 line impedance stabilization network (LISN)

network inserted in the supply leads of an apparatus to be tested which provides, in a given frequency range, a specified source impedance for the measurement of disturbance currents and voltages and which can isolate the apparatus from the supply mains in that frequency range

3.2.11 not operating

condition wherein no power is applied to the equipment

3.2.12 overshield

shield surrounding a bundle or a shielded cable

3.2.13 passive intermodulation product

generation of a signal at frequency $f = n \cdot f_1 + m \cdot f_2$ from two signals at frequencies f_1 and f_2 , where n and m are positive or negative integers, by a passive device, usually an electrical contact

3.2.14 port

place of access to a device or network where energy can be supplied or withdrawn, or where the device or network variables can be observed or measured

3.2.15 power quality requirements

requirements which define the conducted voltage noise or impedance the power user can expect

NOTE Noise e.g. from load regulation, spikes, and sags.

3.2.16 soft magnetic material

ferromagnetic material with a coercivity smaller than 100 A/m

3.2.17 spurious emission

electromagnetic emission from the intended output terminal of an electronic device, but outside of the designed emission bandwidth

3.2.18 test antenna

antenna of specified characteristics designated for use under specified conditions in conducting tests

3.2.19 unit

equipment that is viewed as an entity for purposes of analysis, manufacturing, maintenance, or record keeping

NOTE E.g. hydraulic actuators, valves, batteries, and individual electronic boxes such as on-board computer, inertial measurement unit, reaction wheel, star tracker, power conditioning unit, transmitters, receivers, or multiplexers.

3.3 Abbreviated terms

For the purpose of this standard, the abbreviated terms of ECSS-S-ST-00-01 and the following apply:

Abbreviation	Meaning
AC	alternating current
ACS	attitude control system
AM	amplitude modulation
AWG	American wire gauge
BCI	bulk cable injection
CE	conducted emission
CS	conducted susceptibility
CW	continuous wave
DC	direct current
EED	electro-explosive device
EGSE	electrical ground support equipment
EHF	extremely high frequency (30 GHz-300 GHz)
EMC	electromagnetic compatibility

EMCAB	electromagnetic compatibility advisory board
EMCCP	electromagnetic compatibility control plan
EMEVP	electromagnetic effects verification plan
EMEVR	electromagnetic effects verification report
EMI	electromagnetic interference
EMISM	electromagnetic interference safety margin
ESD	electrostatic discharge
EUT	equipment under test
HV	high voltage
ICD	interface control document
LEO	low Earth orbit
LF	low frequency
LISN	line impedance stabilization network
MGSE	mechanical ground support equipment
PAM	pulse amplitude modulation
PCM	pulse coded modulation
RE	radiated emission
RF	radio frequency
r.m.s.	root-mean-square
RS	radiated susceptibility
SHF	super-high frequency (3 GHz-30 GHz)

4 Requirements

4.1 General system requirements

EMC policy and general system requirements, and the spacecraft charging protection program are specified in ECSS-E-ST-20 Electromagnetic Compatibility clause and EMC Plan DRD.

4.2 Detailed system requirements

4.2.1 Overview

This clause 4.2 defines the requirements for design and realization at system level. They are the basis for definition of activities of the EMC programme to ensure space-system-level compatibility with minimum impact to programme, cost, schedule, and operational capabilities.

4.2.2 EMC with the launch system

4.2.2.1 Overview

General system requirements for “EMC with the launch system” are defined in ECSS-E-ST-20.

4.2.2.2 Detailed system requirements

ECSS-E-ST-20-07_0080001

- a. Overload capability of the spacecraft RF receivers during the pre-launch and launch phases with or without fairing, shall be demonstrated by the spacecraft supplier.

NOTE 1 It is expected the electromagnetic environment generated by companion payloads is assessed by the launching company and addressed in the User’s Manual.

NOTE 2 A conductive fairing is likely to cause resonances and cavity effects.

ECSS-E-ST-20-07_0080002

- b. Spacecraft equipment shall not exhibit any malfunction, degradation of performance or deviation beyond the tolerance indicated in its individual specification after being exposed, even not operating, to the electromagnetic environment from the launcher and launch site.

NOTE Most of spacecraft equipment is not operating during launch. During the launching sequence spacecraft transmitters and receivers (platform and payload) can be either in OFF- or ON-state depending on the launch vehicle.

ECSS-E-ST-20-07_0080003

- c. The electromagnetic interference safety margin (EMISM) of safety critical equipment shall be applied to equipment in ON-state during prelaunch and launch phase and to EEDs.

4.2.3 Lightning environment

4.2.3.1 Overview

Protection of the space system against both direct and indirect effects of lightning can be a combination of operational avoidance of the lightning environment and electrical overstress design techniques.

4.2.3.2 Requirements to the space system

ECSS-E-ST-20-07_0080004

- a. Assessment of risk, on the launch pad inside the protected area, for the space system and its equipment against direct and indirect effects of lightning before lift-off, shall be performed.

ECSS-E-ST-20-07_0080005

- b. The spacecraft supplier shall obtain from the launching company the electromagnetic environment imposed on the launcher payloads in case of lightning.

4.2.4 Spacecraft charging and effects

4.2.4.1 Overview

Mitigation of risks related to spacecraft charging results of a combination of rules and methods preventing voltage build-up and so minimizing the occurrence of ESD, and techniques for controlling EMI from residual ESD.

ECSS-E-ST-20 addresses management of spacecraft charging protection and system-level performance under effects of spacecraft charging and related ESD or secondary arcs.

ECSS-E-ST-20-06 addresses charging control and risks arising from spacecraft charging and other environmental effects on the spacecraft's electrical behaviour.

4.2.4.2 EMI control requirements to system and equipment in relation with ESD

ECSS-E-ST-20-07_0080006

- a. Analysis or tests at system level shall be performed for assessing the threat at subsystem or equipment level.

NOTE Analysis or tests can be defined in the time or frequency domain. They are expected to evaluate the coupling level from the ESD source to critical points.

ECSS-E-ST-20-07_0080007

- b. EMI control from residual ESD shall be performed by a combination of shielding and passive or active filtering techniques, implemented on the main structure, at subsystem level or inside equipment.

ECSS-E-ST-20-07_0080008

- c. EMI control efficiency shall be verified by test at subsystem or equipment level.

4.2.5 Spacecraft DC magnetic emission

4.2.5.1 Spacecraft with susceptible payload

ECSS-E-ST-20-07_0080009

- a. As part of the EMCCP, a magnetic cleanliness control plan shall document:
1. magnetic control guidelines
 2. emission limits to magnetic sources
 3. a magnetic budget
 4. specific test methods applied to equipments for emission measurement and characterization

NOTE The test method described in 5.4.5 providing a dipole model can be inadequate and replaced by a multiple dipole model or a spherical harmonics model.

4.2.5.2 Attitude control system (ACS)

ECSS-E-ST-20-07_0080010

- a. As part of the EMCCP, a magnetic budget shall be maintained providing:
1. Three-axes components of the space vehicle magnetic dipole (component decreasing with the inverse cube law with distance).

2. If the solar array is rotating in the space vehicle axes, separate evaluation for the main body and the solar array.
3. When the space vehicle is using a magnetic sensor as part of the ACS, evaluation of the magnetic induction at its location.

NOTE 1 to item 1: Typical values lie in the range 1 Am² or less for small spacecraft to much more than 10 Am² for large spacecraft.

NOTE 2 to item 3: The angular deviation is the basic requirement; however, the requirement is generally expressed in terms of modification of the natural field strength at the sensor location. For LEO spacecraft if the error on each axis is less than 1 μ T, the modification of the direction is kept less than 20 milliradians.

ECSS-E-ST-20-07_0080011

- b. The specified maximum magnetic field value shall comprise the remanent magnetization (magnets, electro-magnets in off-state, or residual perm-up due to hysteresis of soft materials), the induced magnetization of soft materials by the geomagnetic field, and the momentum of current loops.

4.2.6 Radiofrequency compatibility

ECSS-E-ST-20-07_0080012

- a. Spurious emissions requirements at antenna ports shall be specified for RF compatibility purpose by the spacecraft supplier.

ECSS-E-ST-20-07_0080013

- b. When specifying limits and frequency ranges, the following issues shall be included:
 1. sensitivity of possible victim receiver subsystems including out-of-band response,
 2. no limits apply to transmit frequencies and information carrying modulation bandwidths,
 3. highest and lowest intentional frequency used by space system receivers,
 4. antenna port attachments, gain/loss characteristics.

4.2.7 Hazards of electromagnetic radiation

Assessment of hazards to electromagnetic radiation is a part of the process specified in ECSS-Q-ST-40-02 "Hazard analysis", clause "Hazard analysis requirements".

4.2.8 Intrasystem EMC

ECSS-E-ST-20-07_0080014

- a. Intrasystem EMC shall be achieved by:
1. allocation of equipment-level EMI requirements documented in the EMCCP, including:
 - (a) limits on conducted and radiated emission,
 - (b) susceptibility [test limits](#).

ECSS-E-ST-20-07_0080015

2. control of conducted and radiated propagation paths, [as](#) defined by clauses 4.2.10 to 4.2.13.

NOTE to item 1: Recommended data is defined in 5.4.14.4d.6 [for equipment and subsystems](#).

4.2.9 EMC with ground equipment

ECSS-E-ST-20-07_0080016

- a. The EGSE and MGSE used for spacecraft integration and ground testing shall:
1. [not degrade the EMC performance of the spacecraft during AIT;](#)
 2. [be specified to have a known and controlled impact on grounding and isolation when used together with the spacecraft.;](#)
 3. [not impair the ability to verify the EMC performance of the spacecraft during ground testing.](#)

NOTE to item 2: This includes GSE interconnecting elements, such as harness or piping.

ECSS-E-ST-20-07_0080017

- b. The EGSE shall be immune to signals used for spacecraft susceptibility tests.

4.2.10 Grounding

4.2.10.1 Overview

As specified in ECSS-E-ST-20, a controlled ground reference concept is defined for the space system. Structural elements, antenna and RF reference grounds, power and signal returns, shields and cable shields, safety grounds, EGSE grounds are considered.

4.2.10.2 Requirements

ECSS-E-ST-20-07_0080018

- a. A system-level grounding diagram shall be established including the EGSE.

ECSS-E-ST-20-07_0080019

- b. A ground reference shall be identified for each power, signal, or RF source or receiver.

ECSS-E-ST-20-07_0080020

- c. An upper value of common mode voltage shall be specified considering:
1. power quality requirements defined in ECSS-E-ST-20 for “Spacecraft bus”,
 2. type of detectors and sensitivity,
 3. characteristics of analogue signal monitor receiver circuit, in accordance with ECSS-E-ST-50-14, Table 5-2 d,
 4. characteristics of bi-level signal monitor receiver circuit, in accordance with ECSS-E-ST-50-14, clause Table 6-2 e,
 5. hazards due to fault currents internal to the space vehicle or between the space vehicle and its EGSE.

ECSS-E-ST-20-07_0080021

- d. When power and signal share common paths (wire or structure), the magnitude of ground impedance shall be limited over the affected signal spectrum.

NOTE Non-exclusive techniques for reducing the impedance are decrease of common path length, decrease of wire and ground impedance, filters on common paths.

4.2.11 Electrical bonding requirements

4.2.11.1 Overview

Bonding requirements are a mean for fulfilling grounding requirements.

Normative provisions are specified in clause [4.2.11.2](#) and illustrated in [Figure 4-1](#).

NOTE Bonding requirements for charging control are specified in ECSS-E-ST-20-06 “Electrical continuity”, including surfaces and structural and mechanical parts.

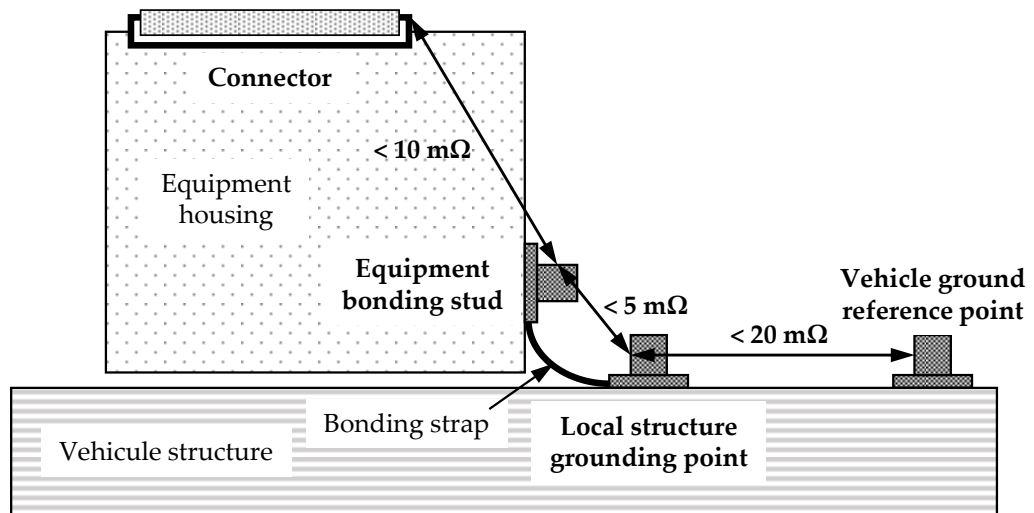

Figure 4-1: Bonding requirements

4.2.11.2 Normative provisions

ECSS-E-ST-20-07_0080023

- a. A vehicle [ground reference point](#) shall be [defined on the vehicle structure](#), as a reference point [for bonding verification](#).

ECSS-E-ST-20-07_0080024

- b. An equipment bonding stud connected to the unit housing shall be provided as a ground reference at equipment level.

ECSS-E-ST-20-07_0080025

- c. Each unit housing shall be bonded to the nearby [local structure grounding point](#) from the equipment bonding stud.

ECSS-E-ST-20-07_0080026

- d. The DC resistance between the equipment bonding stud and the [local structure grounding point](#) shall be less than 5 m Ω .

ECSS-E-ST-20-07_0080027

- e. The [loop](#) inductance between the equipment bonding stud and the nearby spacecraft structure shall be less than 30 nH.

ECSS-E-ST-20-07_0080028

- f. The DC resistance between [each and every local structure grounding point](#) and the vehicle [ground reference](#) point shall be less than 20 m Ω .

ECSS-E-ST-20-07_0080232

- g. The DC resistance between the equipment bonding stud and each connector housing shall be less than 10 m Ω .

ECSS-E-ST-20-07_0080030

- h. Bonds shall be capable to carry the fault currents determined by analysis at system level, without fusing, burning, or arcing.

ECSS-E-ST-20-07_0080031

- i. If the structure is used as the return current path, bonding provisions shall be such that DC and AC voltage drops along power paths comply with clause 4.2.10.2c.

4.2.11.3 External grounds**ECSS-E-ST-20-07_0080032**

- a. The functionality of connecting grounding cables for charge equalization shall be provided on space systems.

NOTE Charge equalization is needed prior to implementing other procedures or the application of power across the interface.

4.2.12 Shielding (excepted wires and cables)**4.2.12.1 Overview**

When shielding is used to control EMC with the environment, it can be provided by the basic space vehicle structure designed as a "Faraday cage", by enclosures of electronics boxes, or by cable or bundle overshields.

4.2.12.2 Requirement**ECSS-E-ST-20-07_0080033**

- a. Electronics units and cables external to the basic space vehicle structure shall have individual shields providing attenuation to EMI.

NOTE It is important to consider apertures used for pressure drop during ascent and for outgassing.

4.2.13 Wiring (including wires and cables shielding)**4.2.13.1 Classification of cables****ECSS-E-ST-20-07_0080034**

- a. Categorisation of harness and separate routings for wires of different categories shall be defined as follows:
 - 1. applicable to critical lines as defined in ECSS-E-ST-20, Clause "Electromagnetic interference safety margin".

2. made on the basis of the characteristics of the signals on the wire (and hence the interference generated), and on the susceptibility of the circuit to EMI.

ECSS-E-ST-20-07_0080035

- b. Wires falling into one category shall be assembled into a same bundle.

ECSS-E-ST-20-07_0080036

- c. Bundles of different categories shall be separated either by a separation distance of 5 cm from the outer circumference or by a metallic screen when they are routed on parallel paths.

NOTE Overshields or spacecraft walls can be used to fulfil the requirement.

ECSS-E-ST-20-07_0080037

- d. Wires and cables shall be marked in such a manner that personnel can visually identify the EMC category for each wire or cable.

4.2.13.2 Cable shields

ECSS-E-ST-20-07_0080038

- a. Cable shields shall not be used as an intentional current carrying conductor, except coaxial cables in radiofrequency circuits and high-speed data links using coaxial cables.

ECSS-E-ST-20-07_0080039

- b. Cable shields, other than overshields, shall have an insulated sheath to prevent uncontrolled grounding.

ECSS-E-ST-20-07_0080040

- c. Connectors used to carry shielded wires shall not use a nonconductive finish.

ECSS-E-ST-20-07_0080041

- d. The bonding of cable shields shall be done as follows:
 1. Bonding to chassis ground is performed at both ends:
 - (a) through the equipment connector body,
 - (b) using a backshell or a dedicated intermediate metal part.

NOTE 1 This is intended to prevent grounding of the shields inside the equipment through a connector ground pin, which favour the propagation of interference.

NOTE 2 Example halo ring is example of dedicated intermediate metal part.

2. <<deleted>>

ECSS-E-ST-20-07_0080042

- e. Overshields shall be bonded to chassis ground:
 - 1. at both ends,
 - 2. using a 360° [connection](#).

ECSS-E-ST-20-07_0080264

- f. [<<deleted>>](#)

5 Verification

5.1 Overview

5.1.1 Introduction

This Clause specifies general conditions for EMC testing, requirements for verification at system level and detailed procedures for unit and subsystem level testing.

5.1.2 Electromagnetic effects verification plan

The electromagnetic effects verification plan (EMEVP) provides the instruction for conducting all activities needed to verify electromagnetic effects requirements. This document defines the approach, methods, procedures, and specific test conditions. The content is specified in the EMEVP DRD of ECSS-E-ST-20. The EMEVP is the vehicle for tailoring procedures and test conditions.

5.1.3 Electromagnetic effects verification report

The electromagnetic effects verification report (EMEVR) documents activities and report analysis or test results in relation with the verification of the electromagnetic effects. It is established based on the electromagnetic effects verification plan (EMEVP). The content of the EMEVR is defined in the EMEVR DRD of ECSS-E-ST-20 supplemented by specific requirements defined hereafter in 0 and 5.4.

5.2 Test conditions

5.2.1 Measurement tolerances

ECSS-E-ST-20-07_0080044

- a. The tolerance for EMC testing shall be as follows:
 1. Distance: ± 5 %
 2. Frequency: ± 2 %
 3. Amplitude, measurement receiver: ± 2 dB
 4. Amplitude, measurement system (includes measurement receivers, transducers, cables, connectors): ± 3 dB

5. Time (waveforms): $\pm 5\%$
6. Resistors: $\pm 5\%$
7. Capacitors: $\pm 20\%$

5.2.2 Test site

5.2.2.1 Overview

Shielded enclosures or unshielded sites are used for testing.

Shielded enclosures prevent external environment signals from contaminating emission measurements and susceptibility test signals from interfering with electrical and electronic items near the test facility.

In unshielded sites, the tests are performed during times and conditions when the electromagnetic ambient is at its lowest level.

5.2.2.2 Shielded enclosures

ECSS-E-ST-20-07_0080045

- a. The enclosures shall be large such that the EUT arrangement requirements of 5.2.6 and antenna positioning requirements described in the individual test procedures are satisfied.

ECSS-E-ST-20-07_0080046

- b. RF absorber material shall be used when performing electric field radiated emissions or radiated susceptibility testing to reduce reflections of electromagnetic energy and to improve accuracy and repeatability.

NOTE Example of RF absorber material are carbon impregnated foam pyramids, and ferrite tiles.

ECSS-E-ST-20-07_0080047

- c. The RF absorber shall be placed above, behind, and on both sides of the EUT, and behind the radiating or receiving antenna as shown in Figure 5-1.

ECSS-E-ST-20-07_0080048

- d. Minimum performance of the material shall be as specified in Table 5-1.

NOTE The manufacturer's specification of their RF absorber material (basic material only, not installed) can be used.

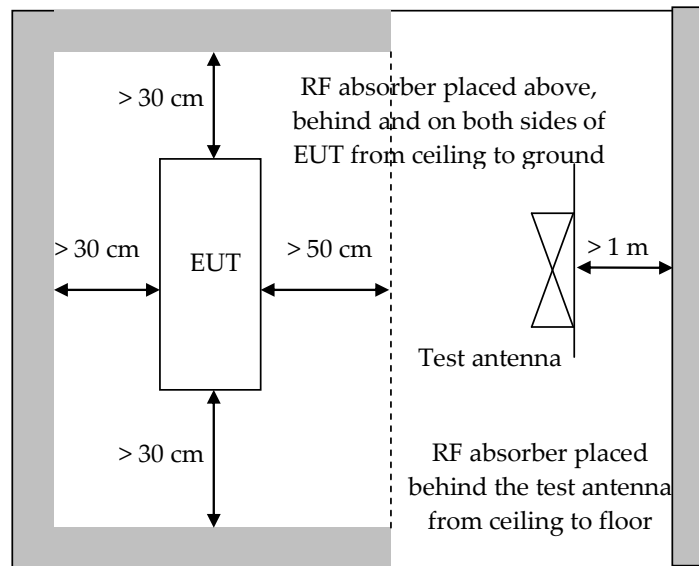

ECSS-E-ST-20-07_0080233

Figure 5-1: RF absorber loading diagram

ECSS-E-ST-20-07_0080234

Table 5-1: Absorption at normal incidence

Frequency	Minimum absorption
80 MHz – 250 MHz	6 dB
above 250 MHz	10 dB

5.2.2.3 Ambient electromagnetic level

ECSS-E-ST-20-07_0080049

- a. The ambient electromagnetic level shall be measured with the EUT not operating and all auxiliary equipment turned on.

ECSS-E-ST-20-07_0080050

- b. During testing, at least one of the following conditions shall be met:
1. the ambient is at least 6 dB below the individual test limits,
 2. the EUT complies with the individual test limits,
 3. it is shown that recorded data exceeding the limits cannot be generated by the EUT (emission tests) or cannot sensitize the EUT (susceptibility tests).

ECSS-E-ST-20-07_0080051

- c. Background plots shall be reported for each test configuration unless all recorded data is at least 6 dB below the individual test limits.

5.2.2.4 Ambient conducted level**ECSS-E-ST-20-07_0080052**

- a. Ambient conducted levels on power leads shall be measured with the leads disconnected from the EUT and connected to a resistive load that draws the same rated current as the EUT.

5.2.3 Ground plane**5.2.3.1 General****ECSS-E-ST-20-07_0080053**

- a. If the actual installation is known, the EUT shall be installed on a ground plane that simulates the actual installation.

ECSS-E-ST-20-07_0080054

- b. If the actual installation is unknown or multiple installations are expected, then the EUT shall be installed on a metallic ground plane.

ECSS-E-ST-20-07_0080055

- c. Ground planes shall be 2 m² or larger in area with the smaller side no less than 75 cm.

ECSS-E-ST-20-07_0080056

- d. When a ground plane is not present in the actual EUT installation, the EUT shall be placed on a non-conductive table.

NOTE In such a case, test methods are specific and are likely to differ from the ones in the present standard.

5.2.3.2 Metallic ground plane**ECSS-E-ST-20-07_0080057**

- a. When the EUT is installed on a metallic ground plane, the ground plane shall have a DC surface resistance not larger than 0,1 m Ω per square.

ECSS-E-ST-20-07_0080058

- b. The DC resistance between metallic ground planes and the shielded enclosure shall be 2,5 m Ω or less.

ECSS-E-ST-20-07_0080059

- c. The metallic ground planes shall be electrically bonded to the floor or wall of the basic shielded room structure at least once every 1 m.

ECSS-E-ST-20-07_0080060

- d. The metallic bond straps shall be solid and maintain a five-to-one ratio or less in length to width.

ECSS-E-ST-20-07_0080061

- e. Metallic ground planes used outside a shielded enclosure shall extend at least 1,5 m beyond the test setup boundary in each direction.

5.2.3.3 Composite ground plane

ECSS-E-ST-20-07_0080062

- a. When the EUT is installed on a conductive composite ground plane, the surface resistivity of the actual installation shall be used.

ECSS-E-ST-20-07_0080063

- b. Composite ground planes shall be electrically bonded to the enclosure with means suitable to the material.

5.2.4 Power source impedance

ECSS-E-ST-20-07_0080064

- a. The impedance of power sources providing input power to the EUT shall be controlled by Line Impedance Stabilization Networks (LISNs) for all measurement.

ECSS-E-ST-20-07_0080065

- b. LISNs shall not be used on output power leads.

ECSS-E-ST-20-07_0080066

- c. The LISNs shall be located at the power source end of the exposed length of power leads specified in 5.2.6.6.

ECSS-E-ST-20-07_0080067

- d. The LISN circuit shown in Figure 5-2 shall be used.

NOTE 1 The LISN can be split in several cases, one per power lead.

NOTE 2 The series inductances represent the inductances of the wiring; the series resistances represent the resistances of the wiring and of the central protections.

- NOTE 3 The 50 Ω resistors result in 100 Ω at high frequency, similar to the characteristic impedance of the line.
- NOTE 4 The feed-through capacitors provide a short-circuit at high frequency and make the LISN symmetrical.
- NOTE 5 The large capacitor (between 1 mF and 10 mF) provides sufficiently low impedance at low frequency, and a reserve a charge.

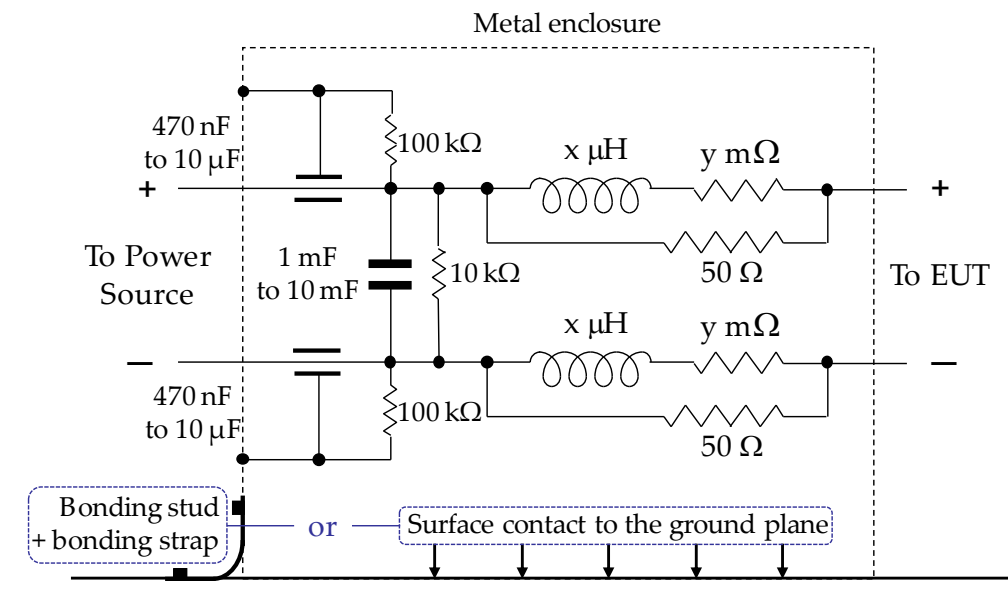

ECSS-E-ST-20-07_0080235

Figure 5-2: Line impedance stabilization network schematic

ECSS-E-ST-20-07_0080068

- e. If no value is specified $x = 2 \mu\text{H}$ and $y = 0,1 \Omega$ shall be used.

NOTE The x and y values, respectively the inductance and the resistance inserted in each lead are expected in the EMEVP.

ECSS-E-ST-20-07_0080069

- f. Magnetic coupling between inductors shall be avoided.

ECSS-E-ST-20-07_0080070

- g. If the return line is grounded at the power source in the actual installation (star distribution), the return line of the LISN shall be grounded on the power source side.

ECSS-E-ST-20-07_0080071

- h. If structure return is used in the actual installation of the relevant space segment element, the return input of the LISN shall be grounded and the return output of the LISN be left open.

ECSS-E-ST-20-07_0080072

- i. The LISN impedance shall be measured at least annually under the following conditions:
 - 1. the impedance, measured between the power output lead on the EUT side of the LISN and the metal enclosure of the LISN,
 - 2. an unterminated power input terminal on the power source side of the LISN.

ECSS-E-ST-20-07_0080xxx

- j. The LISN shall either be electrically bonded to the ground plane by surface metal-to-metal contact or connected to the ground plane by one or several bonding straps.

ECSS-E-ST-20-07_0080xxx

- k. The LISN should be electrically bonded to the ground plane by surface metal-to-metal contact.

ECSS-E-ST-20-07_0080xxx

- l. The DC resistance between the metal enclosure of the LISN and the ground plane shall be less than 2,5 mΩ.

5.2.5 General test precautions

5.2.5.1 Safety

ECSS-E-ST-20-07_0080073

- a. Clause 4.2.7 shall apply for tests involving high electromagnetic power or high voltage test equipment.

5.2.5.2 Excess personnel and equipment

ECSS-E-ST-20-07_0080074

- a. Only the equipment and the personnel used to perform the test shall be present in the test area or enclosure.

5.2.5.3 Overload precautions

ECSS-E-ST-20-07_0080075

- a. Checks shall be performed to assure that an overload condition does not exist.

NOTE Measurement receivers and transducers are subject to overload, especially receivers without preselectors and active transducers.

- b. Overload condition shall be corrected.

NOTE This can be done by instrumentation changes.

5.2.6 EUT test configurations

5.2.6.1 General

ECSS-E-ST-20-07_0080077

- a. The general test setup for the EUT shall be configured as specified in Figure 5-3 and maintained during all testing.

NOTE For radiated tests, it is desirable to have the LISN outside of the shielded room.

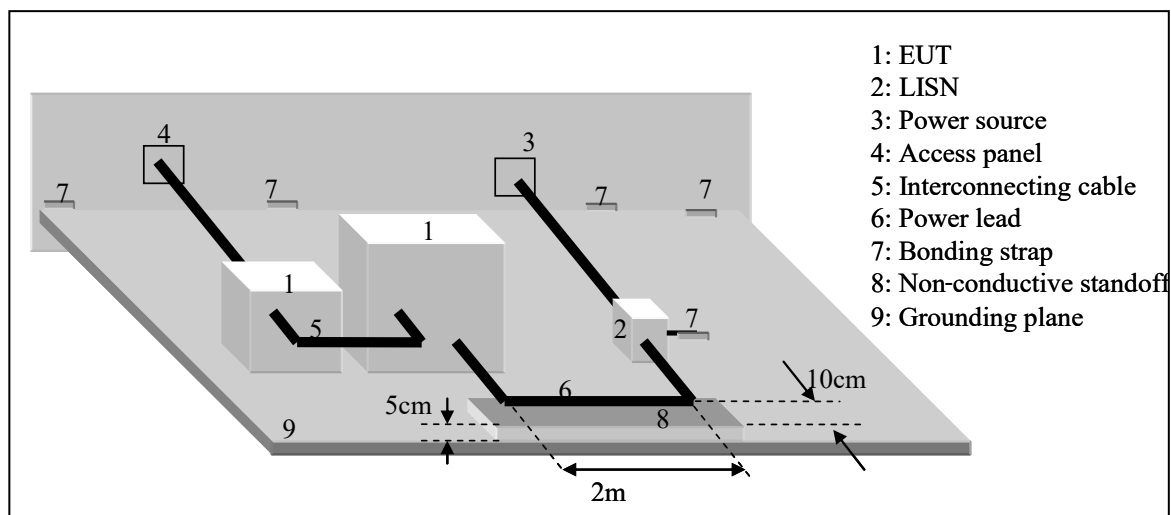

ECSS-E-ST-20-07_0080236

Figure 5-3: General test setup

5.2.6.2 Bonding of EUT

ECSS-E-ST-20-07_0080078

- a. Only the provisions included in the design of the EUT shall be used to bond units.

5.2.6.3 Shock and vibration isolators

ECSS-E-ST-20-07_0080079

- a. EUTs shall be secured to mounting bases having shock or vibration isolators if such mounting bases are used in the actual installation

ECSS-E-ST-20-07_0080080

- b. The bonding straps furnished with the mounting base shall be connected to the ground plane.

ECSS-E-ST-20-07_0080081

- c. When mounting bases do not have bonding straps, bonding straps shall not be used in the test setup.

5.2.6.4 Safety grounds

ECSS-E-ST-20-07_0080082

- a. When external terminals, connector pins, or equipment grounding conductors are available for safety ground connections and are used in the actual installation, they shall be connected to the ground plane.

NOTE Arrangement and length are specified in 5.2.6.6.

5.2.6.5 Orientation of EUTs

ECSS-E-ST-20-07_0080083

- a. EUTs shall be oriented such that surfaces that produce maximum radiated emissions and respond most readily to radiated signals face the measurement antennas.

ECSS-E-ST-20-07_0080084

- b. Bench mounted EUTs comprising interconnecting cables shall be located (10 ± 2) cm from the front edge of the ground plane.

5.2.6.6 Construction and arrangement of EUT cables

5.2.6.6.1 General

ECSS-E-ST-20-07_0080085

- a. Electrical cable assemblies shall [be the same as in the actual installation, in terms of twisting, shielding, and shield terminations.](#)

NOTE Details on the cable construction used for testing are defined in the EMEVP DRD of ECSS-E-ST-20, and maintained in the EMEVR DRD of ECSS-E-ST-20.

ECSS-E-ST-20-07_0080086

- b. Shielded cables or shielded leads (including power leads and wire grounds) within cables shall be used only if they have been specified in installation requirements.
- c. [Connector savers can affect the test results, in particular radiated emission test results, and therefore shall either not be used, or be chosen or modified in such a way as to ensure shield continuity.](#)

5.2.6.6.2 Interconnecting leads and cables

ECSS-E-ST-20-07_0080087

- a. Individual leads shall be grouped into cables in the same manner as in the actual installation.

ECSS-E-ST-20-07_0080088

- b. Up to 10 m, interconnecting cable lengths in the setup shall be the same as in the actual installation.

ECSS-E-ST-20-07_0080089

- c. If a cable is longer than 10 m in the actual installation, the cable length in the set up shall be between 10 m and the actual length.

ECSS-E-ST-20-07_0080090

- d. The cable arrangement shall be such that it satisfies the following conditions:

1. At least the first 2 m (except for cables that are shorter in the actual installation) of each interconnecting cable associated with each enclosure of the EUT are run parallel to the front boundary of the setup.
2. Remaining cable lengths are routed to the back of the setup and placed in a zigzagged arrangement.

ECSS-E-ST-20-07_0080091

- e. When the setup includes more than one cable, individual cables shall be separated by 2 cm measured from their outer circumference.

ECSS-E-ST-20-07_0080092

- f. For bench top setups using ground planes, the cable closest to the front boundary shall be placed 10 cm from the front edge of the ground plane.

ECSS-E-ST-20-07_0080093

- g. All cables shall be supported 5 cm above the ground plane (except for interconnecting cables between enclosures of the EUT that are higher in the actual installation).

h. Intermediate grounding points of overall cable bundles shields existing in the actual installation shall not be implemented in the EMC test set-up.

i. For signal cable bundles, the overall shield, if present, and the individual shields should be bonded to the test set-up boundary to the EGSEs, either to the relevant edge of the metallic ground plane or to the access panel between the control room and the test chamber.

5.2.6.6.3 Input power leads

ECSS-E-ST-20-07_0080094

- a. Two metres of input power leads (including neutrals and returns) shall be routed parallel to the front edge of the setup in the same manner as the interconnecting leads.

ECSS-E-ST-20-07_0080095

- b. Each input power lead, including neutrals and returns, shall be connected to a LISN.

ECSS-E-ST-20-07_0080096

- c. Power leads that are bundled, as part of an interconnecting cable in the actual installation, shall be configured in the same fashion for the 2 m exposed length and then shall be separated from the bundle and routed to the LISNs.

ECSS-E-ST-20-07_0080097

- d. After the 2 m exposed length, the power leads shall be terminated at the LISNs in such a manner that the total length of power lead from the EUT electrical connector to the LISNs shall not exceed 2,5 m.

ECSS-E-ST-20-07_0080098

- e. All power leads shall be supported 5 cm above the ground plane.

ECSS-E-ST-20-07_0080099

- f. If the power leads are twisted in the actual installation, they shall be twisted up to the LISNs.

5.2.6.7 Electrical and mechanical interfaces

ECSS-E-ST-20-07_0080100

- a. Either the actual equipment from the platform installation or loads that simulate the electrical properties present in the actual installation shall terminate electrical input or output interfaces.

NOTE Example of these electrical properties are impedance, grounding and balance.

ECSS-E-ST-20-07_0080101

- b. Signal inputs shall be applied to the electrical interfaces to exercise EUT circuitry.

ECSS-E-ST-20-07_0080102

- c. EUT with mechanical outputs shall be loaded under expected conditions.

ECSS-E-ST-20-07_0080103

- d. When variable electrical or mechanical loading is present in the actual installation, testing shall be performed under expected worst-case conditions.

ECSS-E-ST-20-07_0080104

- e. When active electrical loading is used, it shall be ensured that the active load meets the ambient requirements of 5.2.2 when connected to the setup, and that the active load does not respond to susceptibility signals.

NOTE Example of active electrical loading is the test set.

ECSS-E-ST-20-07_0080105

- f. Antenna ports on the EUT shall be terminated with shielded, matched loads if the RF link is not used during the test.

5.2.7 Operation of EUT

5.2.7.1 General

ECSS-E-ST-20-07_0080106

- a. During emission measurements, the EUT shall be placed in the operating mode, which produces maximum emissions.

ECSS-E-ST-20-07_0080107

- b. During susceptibility testing, the EUT shall be placed in its most susceptible operating mode.

ECSS-E-ST-20-07_0080108

- c. When the EUT has several available modes (including software controlled operational modes), the number of modes to be tested for emission and susceptibility shall be such that all circuitry is evaluated.

NOTE It is expected that the customer defines or agrees operating modes.

5.2.7.2 Operating frequencies for tuneable RF equipment

ECSS-E-ST-20-07_0080109

- a. Measurements shall be performed with the EUT tuned to not less than three frequencies within each tuning band, tuning unit, or range of fixed channels, consisting of one mid-band frequency and a frequency within $\pm 5\%$ from each end of each band or range of channels.

5.2.7.3 Operating frequencies for spread spectrum equipment

ECSS-E-ST-20-07_0080110

- a. Operating frequency requirements for two major types of spread spectrum equipment shall be as follows:
 1. frequency hopping: measurements are performed with the EUT utilizing a hop set which contains a minimum of 30 % of the total possible frequencies, and the hop set is divided equally into three segments at the low, mid, and high end of the EUT operational frequency range,
 2. direct sequence: measurements are performed with the EUT processing data at the highest possible data transfer rate.

5.2.7.4 Susceptibility monitoring

ECSS-E-ST-20-07_0080111

- a. The EUT shall be monitored during susceptibility testing for indications of degradation or malfunction.

NOTE This monitoring is normally accomplished using built-in-test, visual displays, aural outputs, and other measurements of signal outputs and interfaces.

ECSS-E-ST-20-07_0080112

- b. If EUT performance is monitored through installation of special circuitry in the EUT, the modifications shall not influence test results.

5.2.8 Use of measurement equipment

5.2.8.1 Overview

Any frequency selective measurement receiver can be used for performing the testing described in this standard if the receiver characteristics (that is sensitivity, selection of bandwidths, detector functions, dynamic range, and frequency of operation) meet the constraints specified in this standard and are sufficient to demonstrate compliance with the applicable limits.

5.2.8.2 Detector

ECSS-E-ST-20-07_0080113

- a. A peak detector shall be used for all frequency domain emission and susceptibility measurements.

NOTE This device detects the peak value of the modulation envelope in the receiver pass band.

Measurement receivers are calibrated in terms of an equivalent root mean square value of a sine wave that produces the same peak value.

ECSS-E-ST-20-07_0080114

- b. When measurement devices other than peak detector are used for susceptibility testing, correction factors shall be determined and applied for test signals to adjust the reading to equivalent r.m.s. values under the peak of the modulation envelope.

NOTE Example of such measurement devices are oscilloscopes, non-selective voltmeters, and field strength sensors.

5.2.8.3 Calibration fixture (jig)

ECSS-E-ST-20-07_0080115

- a. When current measurements are performed on the central line of a coaxial transmission line a transmission line with 50 Ω characteristic impedance, coaxial connections on both ends, and space for an injection probe around the centre conductor shall be used for calibration.

NOTE Figure 5-4 represents an arrangement described in MIL-STD-461E.

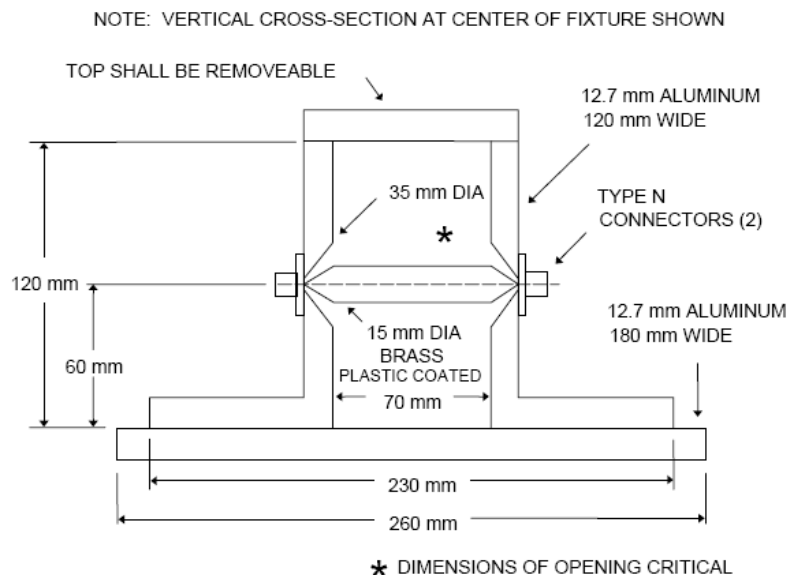

Figure 5-4: Typical calibration fixture

5.2.9 Emission testing

5.2.9.1 Bandwidths

ECSS-E-ST-20-07_0080116

- a. The measurement receiver bandwidths listed in Table 5-2 shall be used for emission testing.

NOTE These bandwidths are specified at the 6 dB down points for the overall selectivity curve of the receivers.

ECSS-E-ST-20-07_0080117

- b. Video filtering shall not be used to bandwidth limit the receiver response.

ECSS-E-ST-20-07_0080118

- c. If a controlled video bandwidth is available on the measurement receiver, it shall be set to its greatest value.

ECSS-E-ST-20-07_0080119

- d. If receiver bandwidths larger than those in Table 5-2 are used, no bandwidth correction factors shall be applied to test data due to the use of larger bandwidths.

NOTE Larger bandwidths can result in higher measured emission levels.

ECSS-E-ST-20-07_0080237

Table 5-2: Bandwidth and measurement time

Frequency Range	6 dB bandwidth	Dwell time	Minimum measurement time (analogue measurement receiver)
30 Hz - 1 kHz	10 Hz	0,15 s	0,015 s/Hz
1 kHz - 10 kHz	100 Hz	0,015 s	0,15 s/kHz
10 kHz - 150 kHz	1 kHz	0,015 s	0,015 s/kHz
150 kHz - 30 MHz	10 kHz	0,015 s	1,5 s/MHz
30 MHz - 1 GHz	100 kHz	0,015 s	0,15 s/MHz
Above 1 GHz	1 MHz	0,015 s	15 s/GHz

5.2.9.2 Emission identification

ECSS-E-ST-20-07_0080120

- a. All emissions regardless of characteristics shall be measured with the measurement receiver bandwidths specified in Table 5-2.

5.2.9.3 Frequency scanning

ECSS-E-ST-20-07_0080121

- a. For emission measurements, the entire frequency range for each test shall be scanned.

ECSS-E-ST-20-07_0080122

- b. Minimum measurement time for analogue measurement receivers during emission testing shall be as specified in Table 5-2.

ECSS-E-ST-20-07_0080123

- c. Synthesized measurement receivers shall step in one-half bandwidth increments or less, and the measurement dwell time shall be as specified in Table 5-2.

ECSS-E-ST-20-07_0080124

- d. For equipment that operates, such that potential emissions are produced at only infrequent intervals, times for frequency scanning shall be increased such that any emission is captured.

5.2.9.4 Emission data presentation

ECSS-E-ST-20-07_0080125

- a. Amplitude versus frequency profiles of emission data shall be automatically generated and displayed at the time of the test.

ECSS-E-ST-20-07_0080126

- b. Except for verification of the validity of the output, data shall not be gathered manually.

ECSS-E-ST-20-07_0080127

- c. The information shall be displayed after application of correction factors, including transducers, attenuators, and cable loss.

ECSS-E-ST-20-07_0080128

- d. Data output of the EUT test result shall be in the form of amplitude over time (for the time domain plots) and amplitude over frequency (for frequency domain plots), superimposed with the EMI test limit.

ECSS-E-ST-20-07_0080129

- e. Units of measurement for frequency domain emissions measurements shall be reported in units of dB referenced to 1 μ V, 1 μ A, 1 μ V/m, 1 pT depending on the unit defined in the test limit.

ECSS-E-ST-20-07_0080130

- f. For time domain measurements, oscilloscope plots shall include the amplitude physical unit (V or A) conversion factors V into A if not done automatically by the oscilloscope, and the oscilloscope sensitivity, time base settings and measurement bandwidth.

ECSS-E-ST-20-07_0080131

- g. For frequency domain plots, emission data shall be reported in graphic form with frequency resolution of 1 %, or twice the measurement receiver bandwidth, whichever is less stringent.

ECSS-E-ST-20-07_0080132

- h. In the event of any emissions test result over the emission test limit above 100 MHz, greater accuracy of its frequency shall be reported with resolution better than or equal to twice the measurement bandwidth.

ECSS-E-ST-20-07_0080133

- i. Each plot of emission data shall be reported with a minimum amplitude resolution of 1 dB.

5.2.10 Susceptibility testing

5.2.10.1 Frequency stepping

ECSS-E-ST-20-07_0080134

- a. For susceptibility measurements, the entire frequency range for each applicable test shall be scanned.

NOTE Stepped scans refer to signal sources that are sequentially tuned to discrete frequencies.

ECSS-E-ST-20-07_0080135

- b. <<deleted, modified and moved to 5.2.10.1g>>

ECSS-E-ST-20-07_0080136

- c. <<deleted, modified and moved to 5.2.10.1i>>.

ECSS-E-ST-20-07_0080XXX

- d. The maximum step size shall not exceed the values specified in Table 5-3, where step sizes are defined in terms of a multiplier of the tuned frequency (f_0) of the signal source.

ECSS-E-ST-20-07 0080XXX

e. If automated testing respecting requirement 5.2.10.1d is not feasible, the EUT shall be tested manually with at least twenty logarithmically spaced frequencies per decade.

ECSS-E-ST-20-07 0080XXX

f. In any case, the following additional test frequencies shall be included:

1. known frequencies where strong emissions exist in the system, to be agreed with the customer;
2. known frequencies where the EUT is expected to be susceptible.

ECSS-E-ST-20-07 0080XXX

g. Stepped scans shall dwell, exclusive of test equipment settling time, at each tuned frequency for the greater of one second or the EUT response time, within the limit of ten seconds.

ECSS-E-ST-20-07 0080XXX

h. If the EUT response time exceeds ten seconds, then the susceptibility test shall be split as follows:

1. normal scan specified in requirements 5.2.10.1d to 5.2.10.1g, performed with one second dwell time.
2. in addition, test at ten discrete frequencies per decade, to be agreed with the customer, with the injection maintained at each frequency for the entire EUT response time.

ECSS-E-ST-20-07 0080XXX

i. Scan rates and step sizes shall be decreased if necessary to permit the observation of a response.

Table 5-3: Maximum step sizes for susceptibility tests

<u>Frequency Range</u>	<u>Stepped scans maximum step size</u>
<u>30 Hz – 100 kHz</u>	<u>0,05 f₀</u>
<u>100 kHz – 3 MHz</u>	<u>0,05 f₀</u>
<u>3 MHz – 30 MHz</u>	<u>0,02 f₀</u>
<u>30 MHz – 50 MHz</u>	<u>0,02 f₀</u>
<u>50 MHz – 200 MHz</u>	<u>0,01 f₀</u>
<u>200 MHz – 1 GHz</u>	<u>0,01 f₀</u>
<u>1 GHz – 18 GHz</u>	<u>0,01 f₀</u>

5.2.10.2 Modulation of susceptibility signals

ECSS-E-ST-20-07_0080137

- a. By default, susceptibility test signals of frequencies higher than 100 kHz shall be pulse modulated (on/off ratio of 40 dB minimum) at 1 kHz, with a duty cycle of 50 %.

ECSS-E-ST-20-07_0080138

- b. By default, susceptibility test signals of frequencies lower than 100 kHz shall be CW.

5.2.10.3 Thresholds of susceptibility

ECSS-E-ST-20-07_0080139

- a. When susceptibility indications are noted in EUT operation, a threshold level shall be determined as follows where the susceptible condition is no longer present:
1. When a susceptibility condition is detected, reduce the interference signal until the EUT recovers.
 2. Reduce the interference signal by an additional 6 dB.
 3. Gradually increase the interference signal until the susceptibility condition reoccurs; the resulting level is the threshold of susceptibility.
 4. Record this level, frequency range of occurrence, frequency and level of greatest susceptibility, and the other test parameters.

5.2.10.4 Susceptibility data presentation

ECSS-E-ST-20-07_0080140

- a. The susceptibility criteria defined in the EMI test procedure shall be repeated in the test report, or the “as run” EMI test procedure shall be an annex to the EMI test report.

ECSS-E-ST-20-07_0080141

- b. Data showing the frequencies and amplitudes at which the test was conducted shall be provided in graphical or tabular form.

ECSS-E-ST-20-07_0080142

- c. Indications of compliance with the requirements shall be provided.

NOTE Such indications can be provision of oscilloscope plots of injected waveforms with test data.

ECSS-E-ST-20-07_0080143

- d. Information shall be displayed after application of correction factors, including transducers, attenuators, and cable loss.

ECSS-E-ST-20-07_0080144

- e. Data shall be reported with frequency resolution of 1 %.

ECSS-E-ST-20-07_0080145

- f. Data shall be provided with a minimum amplitude resolution of 1 dB for each plot.

ECSS-E-ST-20-07_0080146

- g. If susceptibility is observed, determined levels of susceptibility shall be recorded in the test report.

5.2.11 Calibration of measuring equipment

5.2.11.1 General

ECSS-E-ST-20-07_0080147

- a. Measurement antennas, current probes, field sensors, and other devices used in the measurement loop shall be calibrated at least every two years or when damaged.

5.2.11.2 Measurement system test

ECSS-E-ST-20-07_0080148

- a. At the start of each emission test, the complete test system (including measurement receivers, cables, attenuators, couplers, and so forth) shall be verified by injecting a known signal (as stated in the individual test procedure), while monitoring system output for the proper indication.

ECSS-E-ST-20-07_0080265

- b. When the emission test involves an uninterrupted set of repeated measurements using the same measurement equipment, the measurement system test may be accomplished only one time.

NOTE Example of such repeated measurements is the evaluation of different operating modes of the EUT.

5.2.12 Power bus voltage

ECSS-E-ST-20-07_00xxxxx

- a. Conducted emissions tests on the power lines should be performed at the minimum and maximum power bus voltage level.

ECSS-E-ST-20-07_00xxxxx

- b. Inrush current tests should be performed at both minimum and maximum power bus voltage level.

ECSS-E-ST-20-07_00xxxxx

- c. All other tests should be performed at the nominal bus voltage.

5.2.13 Photographic data

ECSS-E-ST-20-07_00xxxxx

- a. Photographs of all EUT test setups and test points and, if applicable, of all calibration setups shall be included in the test report.

NOTE The photographs are meant to provide enough details to allow the test to be reproduced.

5.3 System level

5.3.1 General

ECSS-E-ST-20-07_0080150

- a. Each item of equipment and subsystem shall have successfully passed functional acceptance test procedures as installed on the platform, prior to system level EMC test.

5.3.2 Safety margin demonstration for critical or EED circuits

ECSS-E-ST-20-07_0080151

- a. A test performed to demonstrate compliance with the safety margin requirement shall use one or more of the following test approaches:
 1. Inject interference at critical system points at x dB higher level than exists, while monitoring other system points for improper responses, where $x = EMISM$.
 2. Measure the susceptibility of critical system circuits for comparison to existing interference levels, to determine the margin.
 3. Sensitize the system to render it x dB more susceptible to interference, while monitoring for improper response, where $x = EMISM$.

ECSS-E-ST-20-07_0080152

- b. Safety margin demonstration for something that is susceptible to a time domain circuit (including EEDs) shall use time domain methods.

5.3.3 EMC with the launch system

ECSS-E-ST-20-07_0080153

- a. If the spacecraft is not powered during launch, EMC with the launch system need not be [verified by test](#).

ECSS-E-ST-20-07_0080154

- b. If the spacecraft is powered during launch, the electric field radiated emission, [including intentional transmission, and the electric field radiated susceptibility](#) requirements specified in the Launcher User's manual shall be verified.

ECSS-E-ST-20-07_0080155

- c. In case a spacecraft RF transmitter is operating under fairing, the following EMISMs shall be verified:

1. EMISM with respect to the susceptibility threshold of the EEDs.
2. EMISM with respect to the spacecraft RF receivers' susceptibility threshold (if operational) or damage threshold (otherwise).

NOTE This requirement c. applies also to transmitters which are switched off during launch and ascent but can, for example, be switched on temporarily on the launch pad, for a final health check.

ECSS-E-ST-20-07_0080238

- d. The EMISM between the launch system RF emissions and the spacecraft RF receivers' damage threshold shall be verified.

5.3.4 Lightning

ECSS-E-ST-20-07_0080156

- a. Lightning protection specified in ECSS-E-ST-20 (in clause "Inter-system EMC and EMC with environment"), shall be verified by analysis from equipment demonstration.

NOTE Test at system level is not performed.

5.3.5 Spacecraft and static charging

ECSS-E-ST-20-07_0080157

- a. Material use, bonding of discharge elements, thermal blankets, or metallic items using a bond for static potential equalization shall be verified by inspection or measurement at assembly into structure.

ECSS-E-ST-20-07_0080158

- b. If the bond is only used for charging control, the bonding resistance shall be measured with a dc-current in the range 10 to 100 μ A, under only one polarity, with a 2-wires ohmmeter.

NOTE If the bond is only used for charging control the clauses 5.3.10a and 5.3.10b do not apply.

5.3.6 Spacecraft DC magnetic field emission

ECSS-E-ST-20-07_0080159

- a. Spacecraft DC magnetic field emission requirements shall be verified by a combination of analysis and tests.

5.3.7 Intra–system electromagnetic compatibility

ECSS-E-ST-20-07_0080160

- a. For intra-system EMC tests, the support equipment shall provide the functionality of exercising culprits and victims, and include the support equipment instructions.

ECSS-E-ST-20-07_0080267

- b. Wherever 0 dB EMISM is a requirement, functional tests at spacecraft level may be accepted as a verification of EMC.

5.3.8 Radiofrequency compatibility

ECSS-E-ST-20-07_0080162

- a. Except for passive intermodulation products, radiofrequency compatibility shall be verified by a test at system level.

ECSS-E-ST-20-07_0080163

- b. Absence of passive intermodulation products shall be verified in accordance with the requirements for “Passive intermodulation” specified in ECSS-E-ST-20.

5.3.9 Grounding

ECSS-E-ST-20-07_0080164

- a. The system-level electrical grounding and isolation shall be verified by isolation and continuity tests at system assembly.

NOTE The grounding and isolation design is documented by the system-level grounding diagram including EGSE.

5.3.10 Electrical bonding

ECSS-E-ST-20-07_0080165

- a. Except for bonding used only for charging control, the bonding resistances shall be measured with a milli-ohmmeter or micro-ohmmeter, using a 4-wires method, with a DC test current of 1 A maximum.

ECSS-E-ST-20-07_0080166

- b. Except for bonding used only for charging control, the probes shall be reversed and re-measured to detect possible non-linearity across the bonded junction.

NOTE See clause 5.3.5b.

5.3.11 Wiring and shielding

ECSS-E-ST-20-07_0080167

- a. Wiring category and cable shields shall be verified by review of design and inspection.

5.4 Equipment and subsystem level test procedures

5.4.1 Overview

Test procedures are specified in clauses 5.4.2 through [5.4.12](#) for verifying emission and susceptibility requirements at subsystem or equipment level. Table 5-4 gives the correspondence between procedures and recommended limits defined in 5.4.14d.6.

Table 5-4: Correspondence between test procedures and limits

Informative limit Annex A	Title of test procedure	Verification Clause 5
A.2	CE on power leads, differential mode, 30 Hz to 100 kHz (1st part)	5.4.2
A.2	CE on power leads, differential mode, 100 kHz to 100 MHz (2nd part)	5.4.3
A.3	CE on power leads, in-rush currents	5.4.4
A.4	CE on power and signal leads, common mode, 100 kHz to 100 MHz	5.4.3
A.6	DC magnetic field emission	5.4.5
A.7	RE, low-frequency magnetic field	Specific
A.8	RE, low-frequency electric field	Specific
A.9	RE, electric field, 30 MHz to 18 GHz	5.4.6
A.10	CS, power leads, differential mode, 30 Hz to 100 kHz	5.4.7
A.11	CS, power and signal leads, common mode, 50 kHz to 100 MHz	5.4.8
A.12	CS, power leads, short spike transients	5.4.9
A.13	RS, magnetic field, 30 Hz to 100 kHz	5.4.10
A.14	RS, electric field, 30 MHz to 18 GHz	5.4.11
A.15	Susceptibility to electrostatic discharge	5.4.12

5.4.2 CE, power leads, differential mode, 30 Hz to 100 kHz

5.4.2.1 Purpose

This method is used for measuring conducted emissions in the frequency range 30 Hz to 100 kHz on all input power leads including returns.

5.4.2.2 Test equipment

ECSS-E-ST-20-07_0080168

- a. The test equipment shall be as follows:
1. Measurement receiver,
 2. Current probe,
 3. Signal generator with amplifier,
 4. DC-current supply,
 5. Data recording device,
 6. Oscilloscope,
 7. Coaxial "T" connector and coaxial to bifilar transition,
 8. 1 Ω and 10 Ω power metal film resistors with inductance lower than 100 nH,
 9. LISN defined in 5.2.4.

5.4.2.3 Setup

ECSS-E-ST-20-07_0080169

- a. The test setup shall be as follows:
1. Maintain a basic test setup for the EUT as specified in 5.2.6 and Figure 5-3.
 2. For measurement system check, configure the test setup as shown in Figure 5-5.
 3. For equipment testing, configure the test setup as shown Figure 5-6.

5.4.2.4 Procedure

ECSS-E-ST-20-07_0080170

- a. The test procedures shall be as follows:
1. Turn on the measurement equipment and wait until it is stabilized.
 2. If the EMEVP specifies to check the measurement system, check it by evaluating the overall measurement system from the current probe to the data output device, as follows:
 - (a) Apply a calibrated signal level, at 1 kHz and 100 kHz, which is at least 6 dB below the emission limit to the current probe.
 - (b) Apply through the current probe a DC-current equivalent to the EUT supply current.
 - (c) Verify the AC current level as measured with the probe by comparison with voltage across the 1 Ω resistor at 1 kHz and the 10 Ω resistor at 100 kHz; also, verify that the current waveform is sinusoidal.

- (d) Scan the measurement receiver for each frequency in the same manner as a normal data scan. Verify that the data-recording device indicates a level within ± 3 dB of the injected level.
 - (e) If readings are obtained which deviate by more than ± 3 dB, locate the source of the error and correct the deficiency prior to proceeding with the testing.
3. Test the EUT by determining the conducted emissions from the EUT input power leads, hot line and return, and measure the conducted emission separately on each power lead, as follows:
- (a) Turn on the EUT and wait for its stabilization.
 - (b) Select a lead for testing and clamp the current probe into position.
 - (c) Scan the measurement receiver over the frequency range, using the bandwidths and minimum measurement times specified in Table 5-2, clause 5.2.9.1.
 - (d) Repeat 5.4.2.4a.3(b) and 5.4.2.4a.3(c) for each power lead.

NOTE 1 to item 5.4.2.4a.2(a): A power amplifier can be necessary at 1 kHz.

NOTE 2 to item 5.4.2.4a.2(b): A DC current is applied for verifying that the current probe will not be saturated by the EUT DC supply current.

NOTE 2 to item 5.4.2.4a.2(b): This DC current is applied through the LISN for applying the same impedance through the probe as with the EUT.

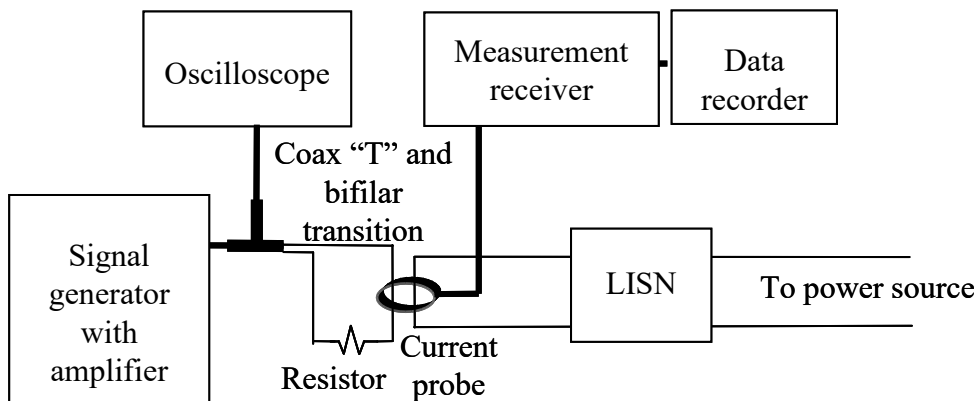

ECSS-E-ST-20-07_0080239

Figure 5-5: Conducted emission, 30 Hz to 100 kHz, measurement system check

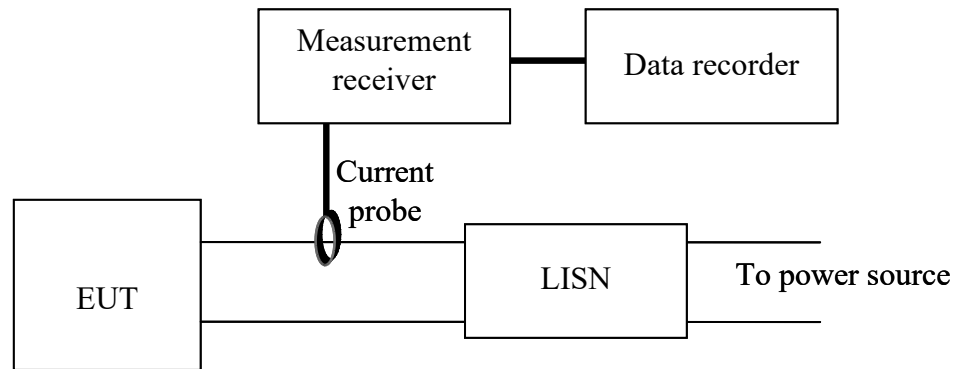

ECSS-E-ST-20-07_0080240

Figure 5-6: Conducted emission, 30 Hz to 100 kHz, measurement setup

5.4.3 CE, power and signal leads, 50 kHz to 100 MHz

5.4.3.1 Purpose

This test procedure is used to verify that electromagnetic emissions from the EUT do not exceed the specified requirements for power input leads including returns, and for common mode emission.

5.4.3.2 Test equipment

ECSS-E-ST-20-07_0080171

- a. The test equipment shall be as follows:
 1. Measurement receiver,
 2. Current probe,
 3. Signal generator,
 4. Data recording device,
 5. Oscilloscope with 50 Ω input,
 6. 50 Ω power divider (6dB "T" connector),
 7. 50 Ω coaxial load,
 8. Calibration fixture defined in 5.2.8.3,
 9. LISNs defined in 5.2.4.

5.4.3.3 Setup

ECSS-E-ST-20-07_0080172

- a. The test setup shall be as follows:

1. Maintain a basic test setup for the EUT as specified in 5.2.6 and Figure 5-3.
2. Configure the test setup for the measurement system check as shown in Figure 5-7.
3. For compliance testing of the EUT:
 - (a) Configure the test setup as shown in Figure 5-8 for differential mode testing and Figure 5-9 for common mode testing.
 - (b) Position the current probe 10 cm from the LISN.

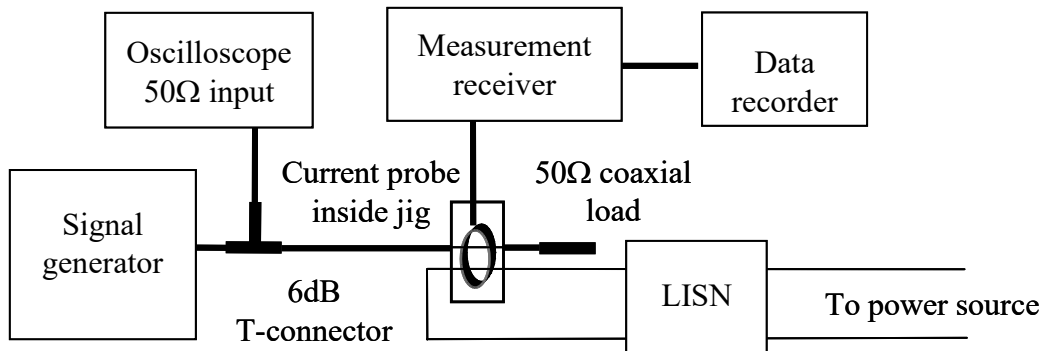

ECSS-E-ST-20-07_0080241

Figure 5-7: Conducted emission, measurement system check

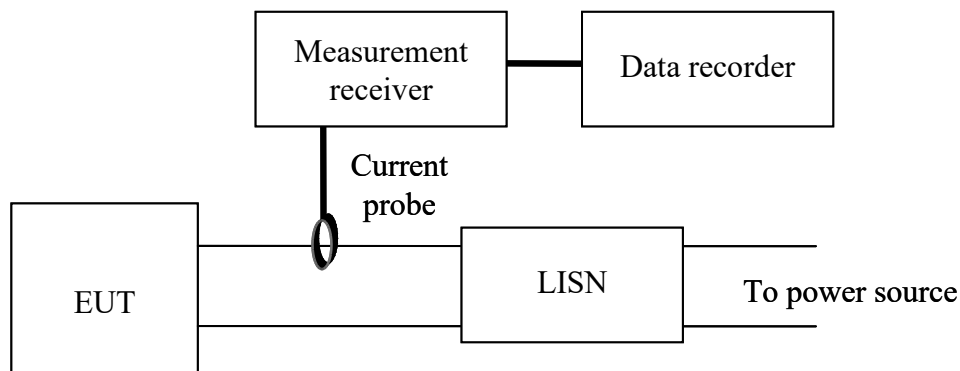

ECSS-E-ST-20-07_0080242

Figure 5-8: Conducted emission, measurement setup in differential mode

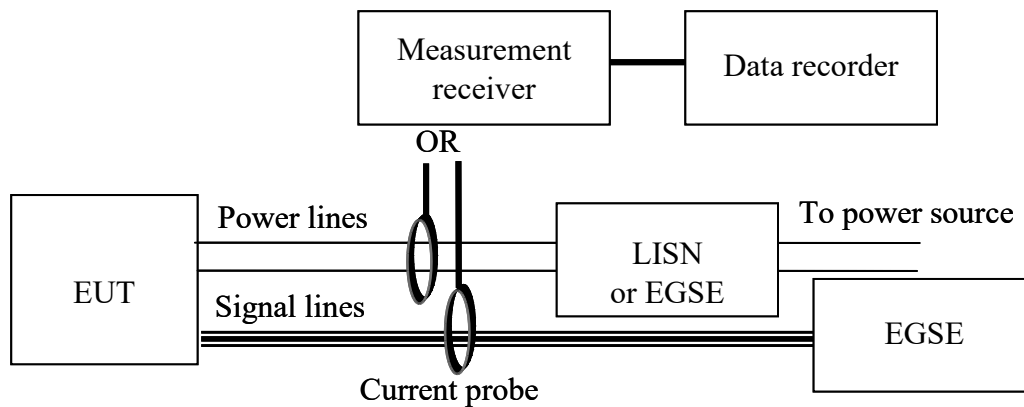

ECSS-E-ST-20-07_0080243

Figure 5-9: Conducted emission, measurement setup in common mode

5.4.3.4 Procedures

ECSS-E-ST-20-07_0080173

- a. The test procedures shall be as follows:
 1. Turn on the measurement equipment and wait until it is stabilized.
 2. If the EMEVP specifies to check the measurement system, check it by evaluating the overall measurement system from the current probe to the data output device, as follows:
 - (a) Apply a calibrated signal level that is at least 6 dB below the applicable limit at 1 MHz and 10 MHz or at a level allowing out of the noise reading on the oscilloscope, whatever is greater, to the current probe in the jig.
 - (b) Apply through the current probe using a second wire, a DC current equivalent to the EUT nominal supply current.
 - (c) Verify the AC current level, as measured with the probe by comparison with the voltage on the T derivation.
 - (d) Scan the measurement receiver for each frequency in the same manner as a normal data scan, and verify that the data-recording device indicates a level within ± 3 dB of the injected level.
 - (e) If readings are obtained which deviate by more than ± 3 dB, locate the source of the error and correct the deficiency prior to proceeding with the testing.
 3. Test the EUT by determining the conducted emission from the input power leads, hot lines and returns separately, and from each interconnecting bundle (common mode), including the ones with power leads, as follows:
 - (a) Turn on the EUT and wait until it is stabilized.

- (b) Select a lead or a bundle for testing and clamp the current probe into position.
- (c) Scan the measurement receiver over the frequency range, using the bandwidths and minimum measurement times specified in Table 5-2, clause 5.2.9.1.
- (d) Repeat 5.4.3.4a.3(b) and 5.4.3.4a.3(c) for each power lead or for each bundle.

NOTE 1 to item 5.4.3.4a.2(b): A DC current is applied for verifying that the current probe will not be saturated by the EUT DC supply current.

NOTE 2 to item 5.4.3.4a.2(b): This DC current is applied through the LISN for applying the same impedance through the probe as with the EUT.

5.4.4 CE, power leads, inrush current

5.4.4.1 Purpose

This test procedure is used to verify that the inrush current of the EUT does not exceed the specified requirements for power input leads.

5.4.4.2 Test equipment

ECSS-E-ST-20-07_0080174

- a. The test equipment shall be as follows:
 - 1. Two-channels oscilloscope,
 - 2. Current probe,
 - 3. Spike generator,
 - 4. Data recording device,
 - 5. Coaxial "T" connector,
 - 6. Coaxial to bifilar transition,
 - 7. 1 Ω power metal film resistor with inductance lower 30 nH and peak power capability,
 - 8. LISN defined in 5.2.4, or 1 to 10 mF capacitor,
 - 9. Switching device, fast bounce-free power switch, or an actual power-controller except if the ON/OFF command is implemented in the EUT.

NOTE 1 A typical example of fast bounce-free power switch is a mercury relay. An electronic switch can be used instead, to avoid using mercury.

NOTE 2 If used, the power-controller represents the central protection actually used on the power bus of the space segment element of interest, for example a LCL.

5.4.4.3 Setup

ECSS-E-ST-20-07_0080175

- a. The test setup shall be as follows:
1. Maintain a basic test setup for the EUT as specified in 5.2.6 and Figure 5-3.
 2. Configure the test setup for the measurement system check as shown in Figure 5-10.
 3. Configure the test setup for compliance testing of the EUT as shown in Figure 5-11.

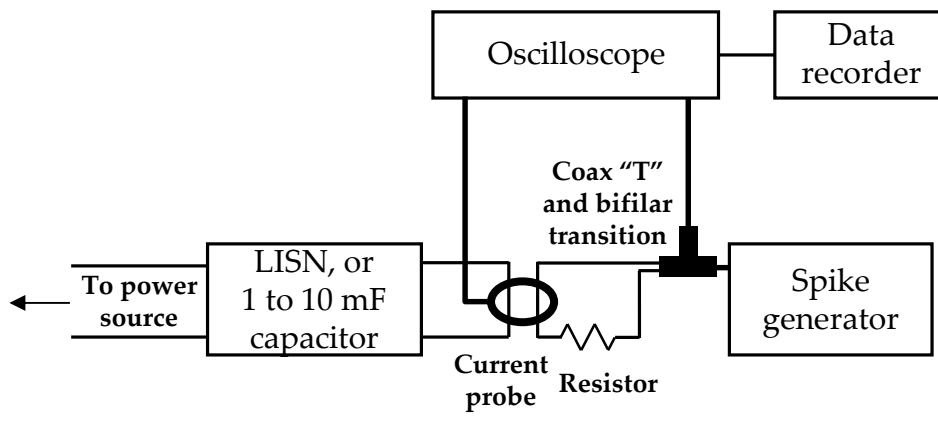

ECSS-E-ST-20-07_0080244

Figure 5-10: Inrush current: measurement system check setup

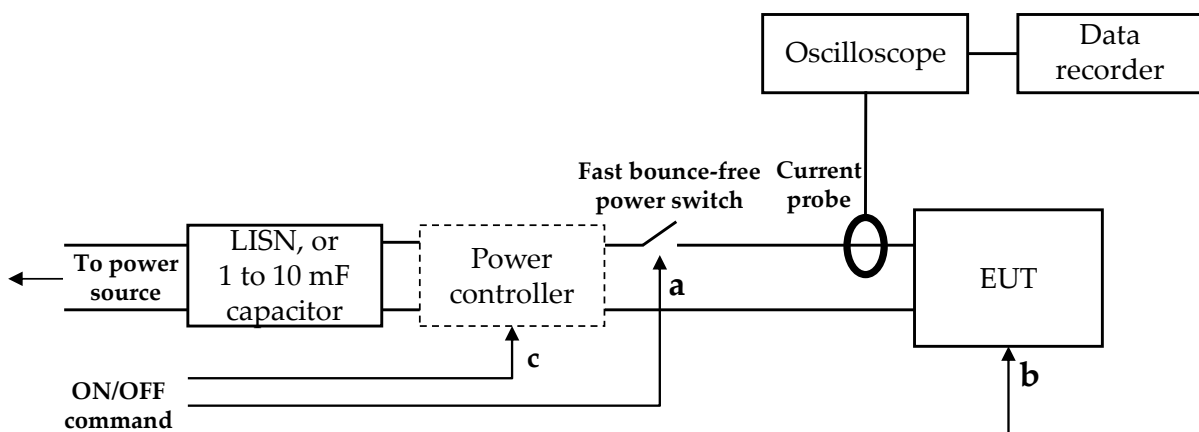

ECSS-E-ST-20-07_0080245

Figure 5-11: Inrush current: measurement setup

5.4.4.4 Procedures

ECSS-E-ST-20-07_0080176

- a. The test procedures shall be as follows:
1. Turn on the measurement equipment and allow a sufficient time for stabilization.
 2. If specified by the EMEVP, check the measurement system by evaluating the overall measurement system from the current probe to the data output device:
 - (a) Apply a calibrated spike that is at least 6 dB below the applicable limit to the current probe.
 - (b) Apply through the current probe a DC current equivalent to the EUT supply current.
 - (c) Check the spike current as measured with the probe by comparison with the voltage across the resistor.
 - (d) Perform the measurement with the current probe on an oscilloscope in the same manner as for EUT testing and verify that the data-recording device indicates a level within ± 3 dB of the injected level.
 - (e) If readings are obtained which deviate by more than ± 3 dB, locate the source of the error and correct the deficiency prior to proceeding with the testing.
 3. Measure the inrush current of the EUT as follows:
 - (a) Select the positive lead for testing and clamp the current probe into position.
 - (b) Arm the oscilloscope for measuring and recording the inrush current.
 - (c) Power on the EUT by means of either a fast bounce-free power switch (Figure 5-11.a), the internal EUT switch (Figure 5-11.b), or the power controller (Figure 5-11.c).

NOTE 1 to item 5.4.4.4a.2(b): A DC current is applied for verifying that the current probe will not be saturated by the EUT DC supply current.

NOTE 2 to item 5.4.4.4a.2(b): This DC current is applied through the LISN for applying the same impedance through the probe as with the EUT.

NOTE 3 to item 5.4.4.4a.3(c): The method for application of power is defined in the EMEVR.

NOTE 4 to item 5.4.4.4a.3(c): The fast switch method (also referred to as hard switch-on or "plug-in") provides the response of the EUT to a voltage step and can therefore be very useful for acceptance.

NOTE 5 to item 5.4.4.4a.3(c): The power controller method allows verifying compatibility with the

central protection device used in the actual space segment element.

NOTE 6 to item 5.4.4.4a.3(c): It is important to ensure that the correct current peak is measured. Specifically, it is important to realise that sometimes the very first short steep current peak is due to the charging of the common mode capacitors and this is not an inrush current in the sense of the present requirement.

5.4.4.5 Data presentation

ECSS-E-ST-20-07_0080177

- a. In addition to 5.2.9.4, data presentation shall be a graphic output of current versus time displaying the transient characteristics with following conditions:
1. amplitude resolution within 3 % of the applicable limit,
 2. time base resolution within 10 % of rise time for measurement of rise and fall slopes.

NOTE Rise time is the duration between 10 % and 90 % of peak-to-peak amplitude

ECSS-E-ST-20-07_0080178

- b. Two separate displays shall be provided showing respectively the initial rise time and the full inrush response.

NOTE Typical time bases are 10 μ s full scale for the initial rise time and 1 ms full scale for the full inrush response.

5.4.5 DC Magnetic field emission, magnetic moment

5.4.5.1 Overview

The described test method allows obtaining a rough estimate of the magnetic moment of the EUT (centred dipole approximation). It involves the double constraint of measuring the magnetic field at distances where such approximation would be valid, while maintaining a sufficient signal-to-noise ratio. There is no guarantee that such distances exist.

If a better model is needed, making it possible to predict the field at closer distances or more precisely than the centred dipole approximation allows, then either multiple dipole modelling techniques or spherical harmonics techniques can be used. They involve much more measurement points than the present so-called "six-points method", typically obtained either from a rotation of the EUT or from a large number of magnetometers.

NOTE It is the role of the EMCAB to assess the need for using such techniques, based on mission requirements.

5.4.5.2 Set-Up

ECSS-E-ST-20-07_0080268

- a. The EUT should be set in an earth field compensated area providing zero-field conditions for the intrinsic moment determination.

NOTE 1 This is necessary in case the EUT contains a significant amount of soft magnetic material, as without earth field compensation an induced magnetic moment would appear.

NOTE 2 Earth field compensation is usually ensured by 2 or 3 sets of Helmholtz coils.

ECSS-E-ST-20-07_0080180

- b. A right-handed orthogonal coordinate system XYZ shall be assigned to the EUT geometric centre.

ECSS-E-ST-20-07_0080181

- c. The magnetic sensor (single-axis magnetometer) shall be installed successively on the 6 semi-axes at two different reference distances r_1 and r_2 from the geometric centre of the EUT and shall measure the field projection along these lines.

NOTE The reference distances are [a compromise between an attempt to favour the possible validity of a centred dipole model and the need to maintain a sufficient signal-to-noise ratio.](#)

ECSS-E-ST-20-07_0080269

- d. Alternatively the EUT may be installed on a turntable and rotated in front of a fixed magnetometer, presenting each XYZ axis (positive and negative) successively aligned with the sensor axis.

ECSS-E-ST-20-07_0080183

- e. The magnetic field shall be positive when [directed](#) from the centre of the EUT towards the magnetometer.

5.4.5.3 Test sequence

ECSS-E-ST-20-07_0080184

- a. The test sequence shall be as follows:
1. EUT not operating, initial measurements on the six semi-axes at the reference distances.

2. Deperm:
 - (a) EUT not operating, application of a deperming field in accordance with Figure 5-12 pseudo-frequency between 2.5 Hz and 5 Hz, maximum amplitude between 4 000 μ T and 5 000 μ T, successively on each XYZ axis of the EUT.
 - (b) Measurement after deperm on the six semi-axes at the reference distances.
3. Perm:
 - (a) EUT not operating, application of a perm field of 300 μ T on each XYZ axis.
 - (b) Measurement after perm on the six semi-axes at the reference distances.
4. Stray field: EUT operating, measurement on the six semi-axes at the reference distances.
5. Final deperm: repeat 5.4.5.3a.2.

NOTE 1 to item 5.4.5.3a.2(a): This is usually done using Helmholtz coils.

NOTE 2 to item 5.4.5.3a.2(a): A sequence of symmetrical sine periods of increasing and decreasing amplitude gives better results than a sine wave modulated by exponentials or ramp functions.

5.4.5.4 Data presentation

ECSS-E-ST-20-07_0080185

- a. For DC magnetic field emission, data shall be presented as follows, superseding clauses 5.2.9.4a through 5.2.9.4i:
 1. For each measurement distance, for each of the 6 semi-axes, the following B-field measurements in μ T are plotted in tabular form:

$$B_{(+x)}, B_{(-x)}, B_{(+y)}, B_{(-y)}, B_{(+z)}, B_{(-z)}$$
 2. For each measurement distance, mean B-field values, for each axis, are computed in units of μ T and plotted in tabular form, using following equations:

$$B_x = \frac{B_{(+x)} - B_{(-x)}}{2}, B_y = \frac{B_{(+y)} - B_{(-y)}}{2}, B_z = \frac{B_{(+z)} - B_{(-z)}}{2}$$
 3. For each measurement distance r , 3-axes magnetic moment components in units of Am^2 are calculated using the following equations and reported:

$$M_x = 5 r^3 B_x \quad M \text{ in units of } \text{Am}^2, r \text{ in meters, } B \text{ in } \mu\text{T}$$

$$M_y = 5 r^3 B_y$$

$$M_z = 5 r^3 B_z$$

4. Using values of M_x , M_y and M_z at both distances r_1 and r_2 , values M_1 and M_2 of the magnetic moment are calculated using the following equations and reported:

$$M_1 = \sqrt{M_x(r_1)^2 + M_y(r_1)^2 + M_z(r_1)^2}$$

$$M_2 = \sqrt{M_x(r_2)^2 + M_y(r_2)^2 + M_z(r_2)^2}$$

NOTE If the EUT is a centred dipolar source, then $M_1 = M_2$.

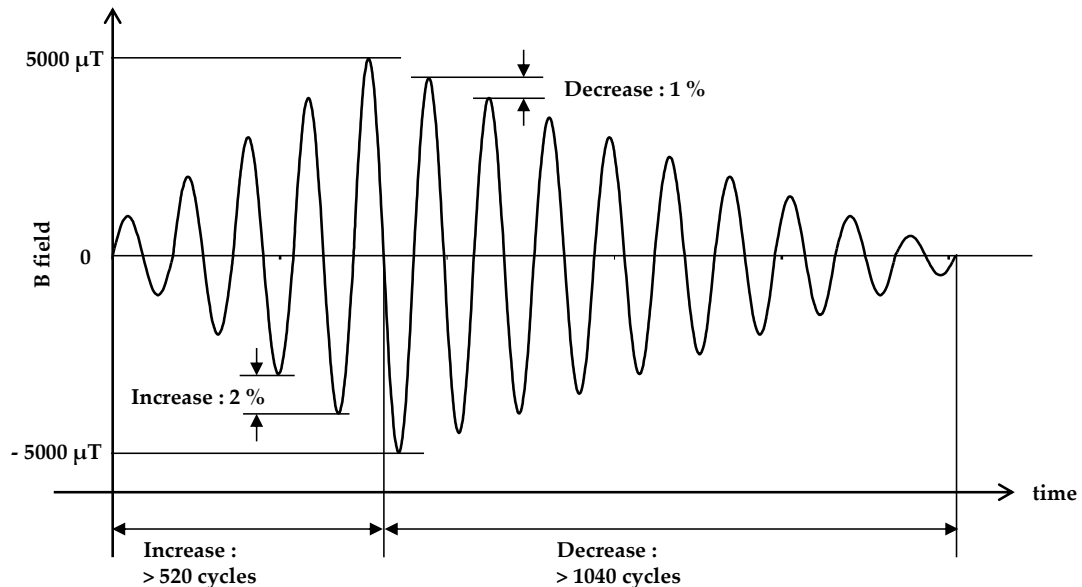

ECSS-E-ST-20-07_0080246

Figure 5-12: Smooth deperm procedure

5.4.6 RE, electric field, 30 MHz to 18 GHz

5.4.6.1 Purpose

This test procedure is used to verify that electric field emissions from the EUT and its associated cabling do not exceed specified requirements.

5.4.6.2 Test equipment

ECSS-E-ST-20-07_0080186

- a. The test equipment shall be as follows:

1. Measurement receiver,
2. Data recording device,
3. Linearly polarized antennas,

(a) biconical, 137 cm tip to tip from 30 MHz to 200 MHz

(b) double ridge horn, 69,0 cm by 94,5 cm opening, from 200 MHz to 1 GHz

(c) double ridge horn, 24,2 cm by 13,6 cm opening, from 1 GHz to 18 GHz

4. Signal generators,
5. Stub radiator,
6. LISN defined in 5.2.4, unless the primary power lines are shielded in the actual installation of the relevant space segment element and in the test setup.

NOTE The LISN is providing a defined common mode impedance.

5.4.6.3 Test setup

ECSS-E-ST-20-07_0080187

- a. A basic test setup for the EUT as shown and described in Figure 5-3 and 5.2.6 shall be maintained to ensure that the EUT is oriented such that the surface that produces the maximum radiated emissions is toward the front edge of the test setup boundary.

ECSS-E-ST-20-07_0080188

- b. The measurement system shall be checked by configuring the test equipment as shown in Figure 5-13.

ECSS-E-ST-20-07_0080189

- c. To test the EUT antenna positioning, the test setup boundary of the EUT and associated cabling for use in positioning of antennas shall be determined.

ECSS-E-ST-20-07_0080190

- d. To test the EUT antenna positioning, the physical reference points on the antennas shown in Figure 5-14 for measuring heights of the antennas and distances of the antennas from the test setup boundary shall be used as follows:
 1. Position antennas 1 m from the front edge of the test setup boundary for all setups.
 2. Position antennas above the floor ground plane.
 3. Ensure that no part of any antenna is closer than 1 m from the walls and 0,5 m from the ceiling of the shielded enclosure.

ECSS-E-ST-20-07_0080191

- e. The antenna positions shall be determined as follows:
 1. For testing below 200 MHz:
 - (a) For setups with the side edges of the boundary 3 m or less, one position, with the antenna centred with respect to the side edges of the boundary.

- (b) For setups with the side edges of the boundary greater than 3 m, N antenna positions at spacing as shown in Figure 5-15, where N is the edge-to-edge boundary distance (in metres) divided by 3 and rounding up to an integer.
2. For testing from 200 MHz up to 1 GHz, place the antenna in such a number of positions that the entire width of each EUT enclosure and the first 35 cm of cables and leads interfacing with the EUT enclosure are within the 3 dB beamwidth of the antenna.
 3. For testing at 1 GHz and above, place the antenna in such a number of positions that the entire width of each EUT enclosure and the first 7 cm of cables and leads interfacing with the EUT enclosure are within the 3 dB-beamwidth of the antenna.

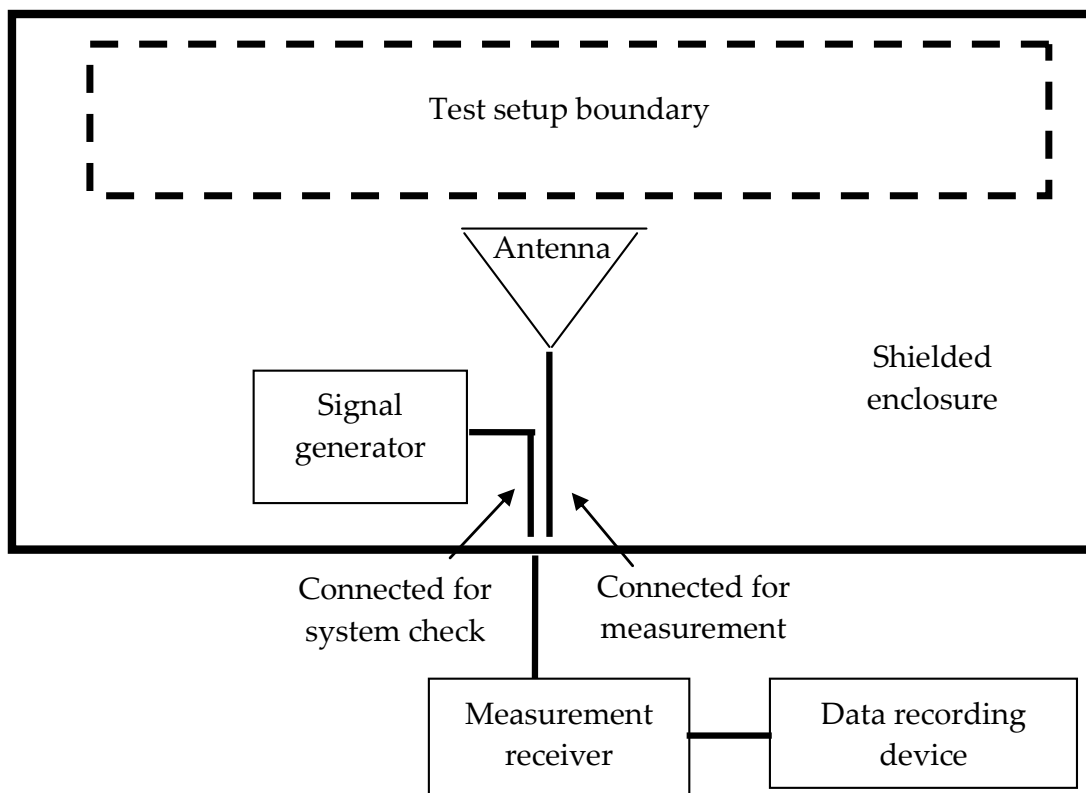

ECSS-E-ST-20-07_0080247

Figure 5-13: Electric field radiated emission. Basic test setup

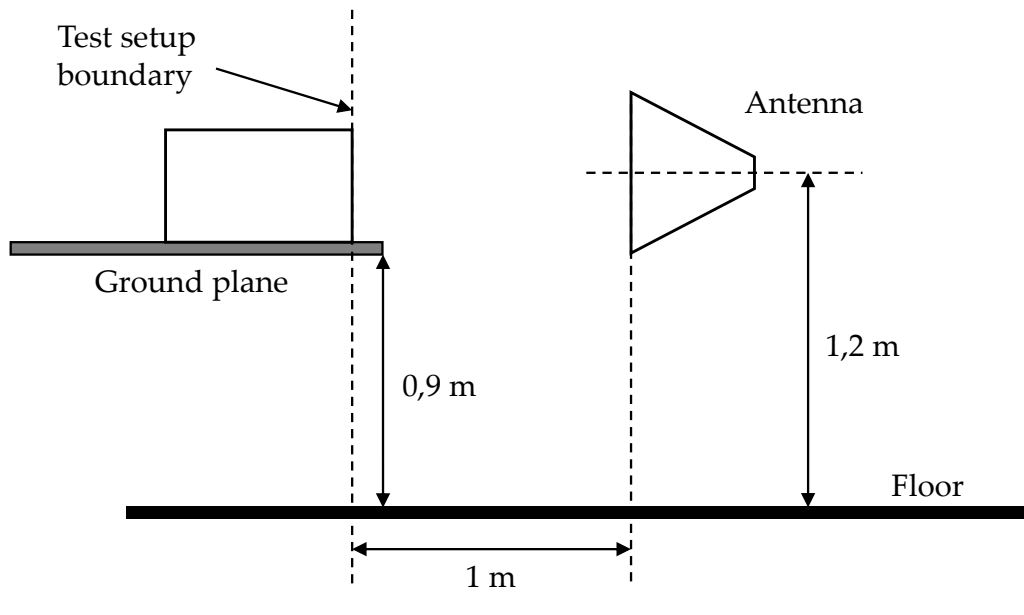

ECSS-E-ST-20-07_0080248

Figure 5-14: Electric field radiated emission. Antenna positioning

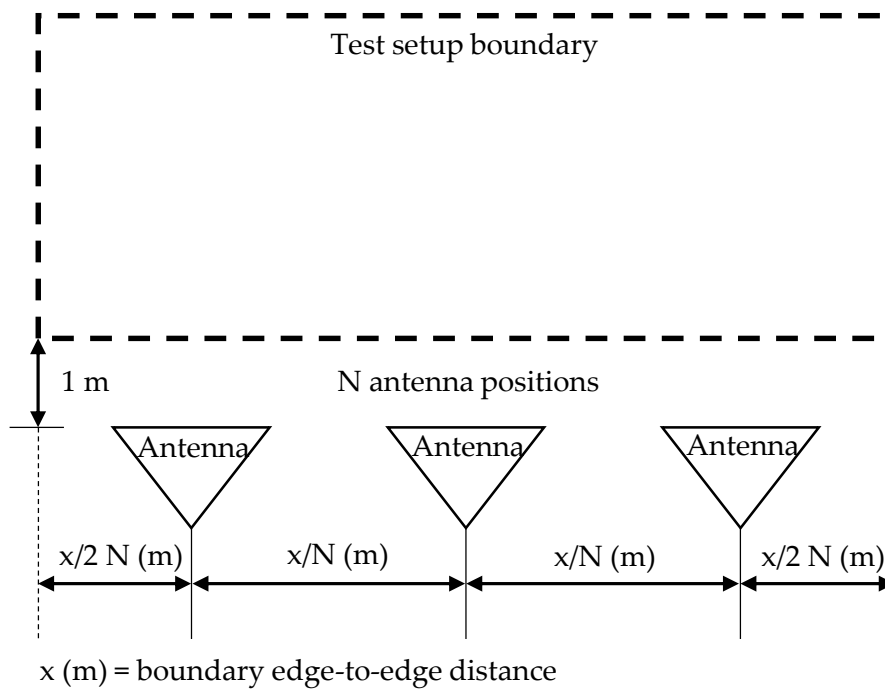

ECSS-E-ST-20-07_0080249

Figure 5-15: Electric field radiated emission – Multiple antenna positions

5.4.6.4 Test procedures

ECSS-E-ST-20-07_0080192

- a. The measurement equipment shall be turned on and [sufficient time allowed for its stabilisation](#).

ECSS-E-ST-20-07_0080193

- b. It shall be verify that the ambient requirements specified in 5.2.2.3 are met and plots of the ambient taken.

ECSS-E-ST-20-07_0080194

- c. The measurement system shall be checked as follows:
 1. Using the system check path of Figure 5-13, perform the following evaluation of the overall measurement system from each antenna to the data output device at the highest measurement frequency of the antenna:
 - (a) Apply a calibrated signal level that is at least 6 dB below the limit (limit minus antenna factor) to the coaxial cable at the antenna connection point.
 - (b) Scan the measurement receiver in the same manner as a normal data scan, and verify that the data-recording device indicates a level within ± 3 dB of the injected signal level.
 - (c) If readings are obtained which deviate by more than ± 3 dB, locate the source of the error and correct the deficiency prior to proceeding with the testing.
 2. Using the measurement path of Figure 5-13, perform the following evaluation for each antenna to demonstrate that there is electrical continuity through the antenna:
 - (a) Radiate a signal using an antenna or stub radiator at the highest measurement frequency of each antenna.
 - (b) Tune the measurement receiver to the frequency of the applied signal and verify that a received signal of appropriate amplitude is present.

NOTE This evaluation is intended to provide a coarse indication that the antenna is functioning properly. There is no requirement to measure accurately the signal level.

ECSS-E-ST-20-07_0080195

- d. The EUT shall be tested by using the measurement path of Figure 5-13 and by determining the radiated emissions from the EUT and its associated cabling as follows:
 1. Turn on the EUT and wait until it is stabilized.

2. Scan the measurement receiver for each applicable frequency range, using the bandwidths and minimum measurement times in 5.2.9.1
3. Orient the antennas for both horizontally and vertically polarized fields.
4. Repeat steps 5.4.6.4d.2 and 5.4.6.4d.3 for each antenna position determined under 5.4.6.3c, 5.4.6.3d, and 5.4.6.3e.

5.4.6.5 Data Presentation

ECSS-E-ST-20-07_0080196

- a. In addition to 5.2.9.4, data presentation shall provide a statement verifying the electrical continuity of the measurement antennas as determined in 5.4.6.4c.1(c).

5.4.7 CS, power leads, 30 Hz to 100 kHz

5.4.7.1 Purpose

This test procedure is used to verify the ability of the EUT to withstand signals coupled on input power leads.

5.4.7.2 Test equipment

ECSS-E-ST-20-07_0080197

- a. The test equipment shall be as follows:
 1. Signal generator,
 2. Power amplifier,
 3. 1,5 Ω to 2,7 Ω power metal film resistor with inductance lower [than](#) 1 00 nH and peak power capability,
 4. Oscilloscopes,
 5. Current probe,
 6. Differential high voltage-probe,
 7. injection transformer,
 8. LISN defined in 5.2.4.

[NOTE](#) [to item 3: This range of values assumes a turns ratio of 2:1.](#)

5.4.7.3 Setup

ECSS-E-ST-20-07_0080198

- a. The test setup shall be as follows:

1. Maintain a basic test setup for the EUT as specified in 5.2.6 and Figure 5-3.
2. Check measurement system by configuring the test equipment in accordance with Figure 5-16, and setting up the oscilloscope to monitor the voltage across the resistor.
3. Test the EUT by configuring the test equipment as shown in Figure 5-17.

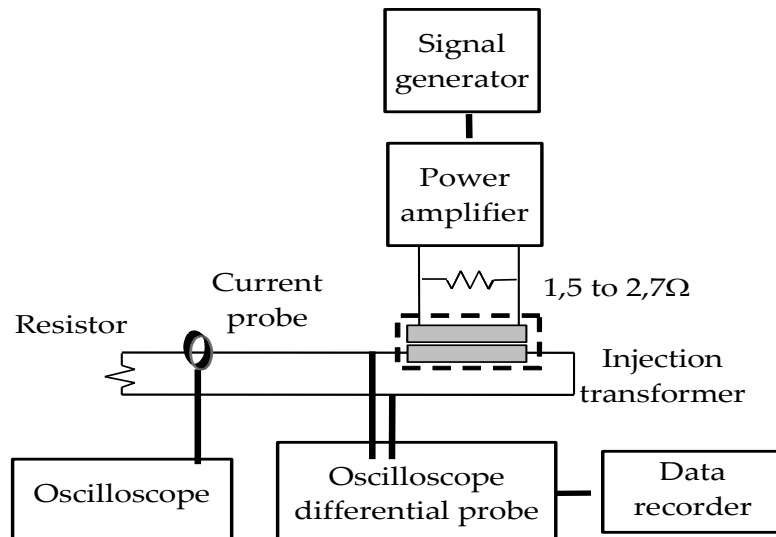

ECSS-E-ST-20-07_0080250

Figure 5-16: CS, power leads, measurement system check set-up

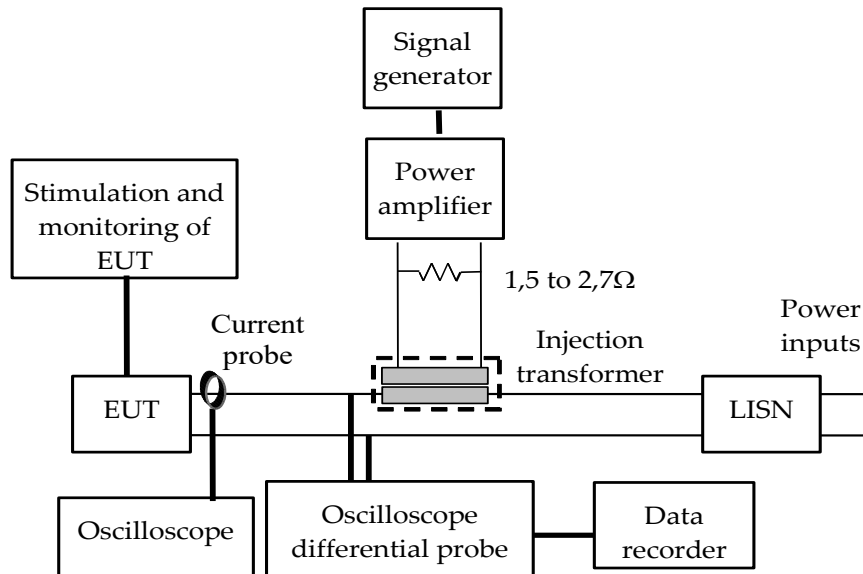

ECSS-E-ST-20-07_0080251

Figure 5-17: CS, power leads, signal injection

5.4.7.4 Procedures

ECSS-E-ST-20-07_0080199

- a. The measurement equipment shall be turned on and [sufficient time allowed for its stabilisation](#).

ECSS-E-ST-20-07_0080200

- b. The measurement system shall be checked using the measurement system check setup for waveform verification as follows:
 1. Set the signal generator to the lowest test frequency.
 2. Increase the applied signal until the oscilloscope indicates the voltage level specified by application of clause 4.2.8, verify that the output waveform is sinusoidal, and verify that the indication given by the current probe is within 3 dB of the expected level derived from the 1 Ω resistor voltage.
 3. Repeat 5.4.7.4b.2 by setting the signal generator to the highest test frequency.

ECSS-E-ST-20-07_0080201

- c. The EUT shall be tested as follows:
 1. Turn on the EUT and wait until it is stabilized.
 2. Set the signal generator to the lowest test frequency, and increase the signal level until the testing voltage or current limit specified by application of clause 4.2.8, is reached on the power lead.

3. Repeat 5.4.7.4c.2 at all frequency steps through the testing frequency range.
4. Evaluate the susceptibility as follows.
 - (a) Monitor the EUT for [signs of susceptibility](#).
 - (b) If susceptibility is noted, determine the threshold level in accordance with 5.2.10.3.
5. Repeat 5.4.7.4c.2 to 5.4.7.4c.4 for each power lead.

5.4.8 CS, bulk cable injection, 50 kHz to 100 MHz

5.4.8.1 Purpose

This test procedure is used to verify the ability of the EUT to withstand sinusoidal waves coupled on the EUT associated cables and power leads.

5.4.8.2 Test equipment

ECSS-E-ST-20-07_0080202

- a. The test equipment shall be as follows:
 1. Signal generator with amplitude or pulse modulation capability,
 2. pulse generator, 1 kHz – 100 kHz, adjustable duty cycle,
 3. power amplifier, 50 kHz – 100 MHz,
 4. current injection probe, 50 kHz – 100 MHz,
 5. current measurement probe, 50 kHz – 100 MHz,
 6. one or two calibration fixture(s) (jigs) defined in 5.2.8.3,
 7. [measurement receivers or spectrum analysers](#),
 8. waveform recording device,
 9. 50 Ω coaxial load,
 10. LISN defined in 5.2.4,
 11. [power meter](#) (optional),
 12. [directional coupler](#).

NOTE to item 7: In clauses 5.4.8.3 to 5.4.8.4, “measurement receiver” means “measurement receiver or spectrum analyser”.

5.4.8.3 Setup

ECSS-E-ST-20-07_0080203

- a. The test setup shall be as follows:
 1. Maintain a basic test setup for the EUT as shown and described in 5.2.6 and Figure 5-3.

2. For calibration:
 - (a) Configure the test equipment in accordance with Figure 5-18.
 - (b) Place the injection probe and the monitor probe around the central conductor of their respective jigs.
 - (c) Terminate one end of the jig, or cascaded jigs, with a 50 Ω -coaxial load and connect the other end to a 50 Ω measurement receiver input.
 - (d) If a current monitor probe is used, connect it to another 50 Ω measurement receiver input.
 - (e) Connect the forward port of the directional coupler to a 50 Ω measurement receiver input or power meter.
3. For testing the EUT:
 - (a) Configure the test equipment as shown Figure 5-20.
 - (b) Place the injection and monitor probes around a cable bundle interfacing an EUT connector.
 - (c) Position the monitor probe:
 - 5 cm from the connector if the overall length of the connector and backshell does not exceed 5 cm,
 - at the overall length of the connector and backshell, otherwise.
 - (d) Position the injection probe 5 cm from the monitor probe.

NOTE 1 to item 5.4.8.3a.2(b): The monitor probe and associated jig are optional.

NOTE 2 to item 5.4.8.3a.2(e): Regarding power meters: some diode power sensors are expected to have enough sensitivity for the calibration levels proposed in A.11, while thermal power sensors are in general expected to lack sensitivity for some of the calibration levels proposed in A.11.

5.4.8.4 Test procedures

ECSS-E-ST-20-07_0080204

- a. The measurement equipment shall be turned on and sufficient time allowed for its stabilisation.

ECSS-E-ST-20-07_0080205

- b. The measurement system shall be calibrated by performing the following procedures using the calibration setup:
 1. Set the frequency of the generator to 50 kHz.
 2. Increase the applied signal until the measurement receiver indicates the level specified by application of clause 4.2.8.

3. Verify that both measurement receivers inputs, levels monitored on 50 Ω and current monitored by the current probe, are consistent within 3 dB. This is applicable only if a current probe is used during calibration.
4. Record the forward power to the injection probe as measured via the directional coupler.
5. Repeat 5.4.8.4b.2 through 5.4.8.4b.4 for each measurement frequency.

ECSS-E-ST-20-07_0080206

- c. The EUT shall be tested by performing the following procedures and using the EUT test setup:
 1. Turn on the EUT and wait until it is stabilized.
 2. Select a bundle for testing and clamp the current probes into position.
 3. If a measurement receiver is used to measure the forward power to the injection probe:
 - (a) Set the unmodulated sine generator to a test frequency, at low output level.
 - (b) Adjust and apply the pulse modulation in duty cycle and frequency, Figure 5-19.
 - (c) Apply the forward power level determined during calibration, without exceeding the current limit specified by application of clause 4.2.8 and record the peak current obtained.
 - (d) Monitor the EUT for signs of susceptibility.
 - (e) If susceptibility is noted, determine the threshold level as measured by the current monitor probe in accordance with 5.2.10.3.
 - (f) Repeat 5.4.8.4c.3(a) through 5.4.8.4c.3(e) for each test frequency.
 4. If a power meter is used to measure the forward power to the injection probe:
 - (a) Set the unmodulated sine generator to a test frequency, at low output level.
 - (b) Apply the forward power level determined during calibration, without exceeding the current limit specified by application of clause 4.2.8 and record the peak current obtained.
 - (c) Adjust and apply the pulse modulation in duty cycle and frequency, Figure 5-19.
 - (d) Monitor the EUT for signs of susceptibility.

- (e) If susceptibility is noted, determine the threshold level as measured by the current monitor probe in accordance with 5.2.10.3.
 - (f) Repeat 5.4.8.4c.4(a) through 5.4.8.4c.4(f) for each test frequency.
5. Repeat 5.4.8.4c.2. and 5.4.8.4c.3 or 5.4.8.4c.4 applying the test signals to each bundle interfacing with each connector or all bundles taken together.

ECSS-E-ST-20-07_0080270

- d. The calibration need not be re-performed before testing each EUT bundle.

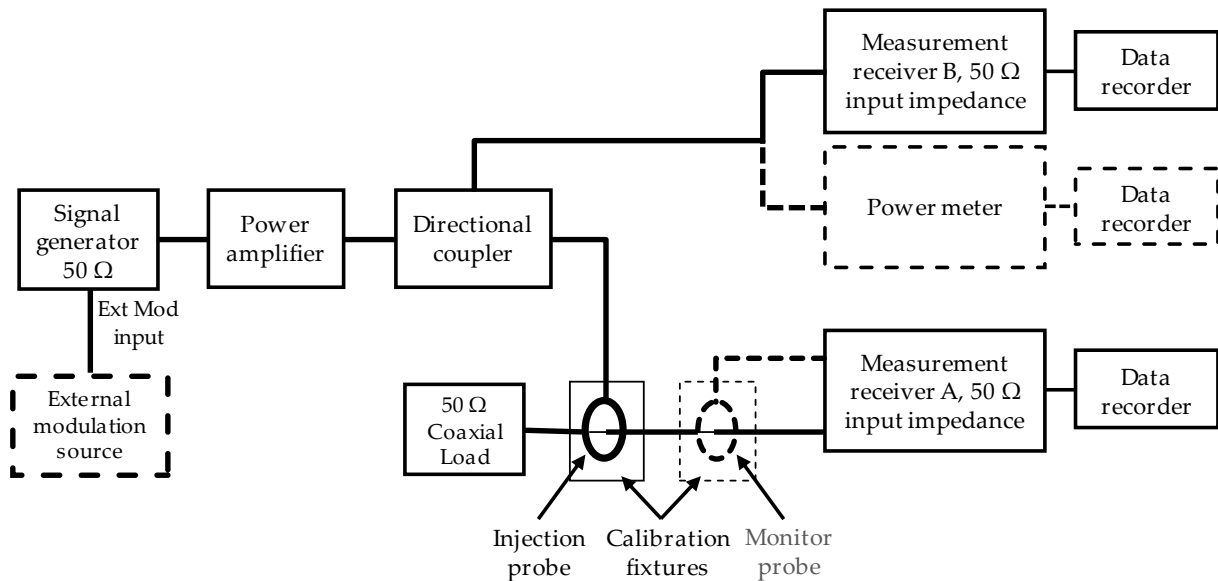

ECSS-E-ST-20-07_0080263

Figure 5-18: Bulk cable injection, calibration set-up

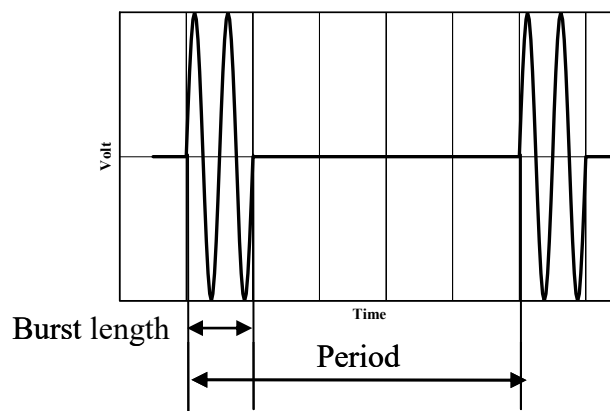

ECSS-E-ST-20-07_0080252

Figure 5-19: Signal test waveform

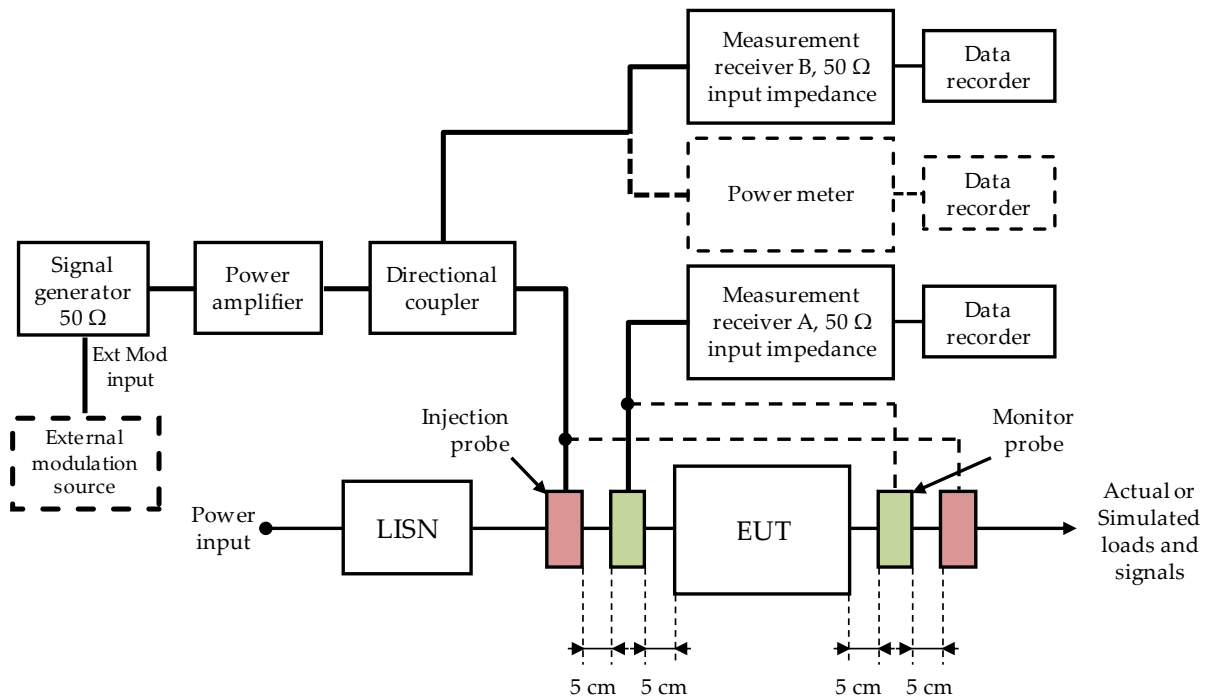

Figure 5-20: CS_x power and signal leads, bulk cable injection

5.4.9 CS, power leads, transients

5.4.9.1 Purpose

This test procedure is used to verify the ability of the EUT to withstand short [transients](#) coupled on EUT power leads.

5.4.9.2 Test equipment

ECSS-E-ST-20-07_0080208

- a. The test equipment shall be as follows:
 1. [Transient](#) generator with [the](#) following characteristics:
 - (a) Pulse width of 10 μs and 0,15 μs,
 - (b) Pulse repetition rate capability up to 10 pulses per second,
 - (c) Voltage output as required, positive then negative,
 - (d) Output control,
 - (e) Adequate transformer current capacity commensurate with line being tested,
 - (f) Output impedance 5 Ω or less for 0,15 μs and 1 Ω or less for 10μs transient,
 - (g) External synchronization and triggering capability.
 2. Oscilloscope with 50 MHz bandwidth or greater.
 3. Differential high-voltage probe.

4. Isolation transformer.
5. 5 Ω resistor power metal film resistor with inductance lower 100 nH and peak power capability.
6. LISN defined in 5.2.4.
7. [Current injection probe.](#)

5.4.9.3 Setup

ECSS-E-ST-20-07_0080209

- a. The test setup [for the differential mode transient](#) shall be as follows:
 1. Maintain a basic test setup for the EUT as specified in 5.2.6 and Figure 5-3.
 2. For calibration:
 - (a) Configure the test equipment in accordance with Figure 5-21 for verification of the waveform.
 - (b) Set up the oscilloscope to monitor the voltage across the 5 Ω resistor.
 3. For EUT testing, configure the test equipment as shown in Figure 5-22.

NOTE [The internal LISN capacitor at the input power side](#) is protecting the source.

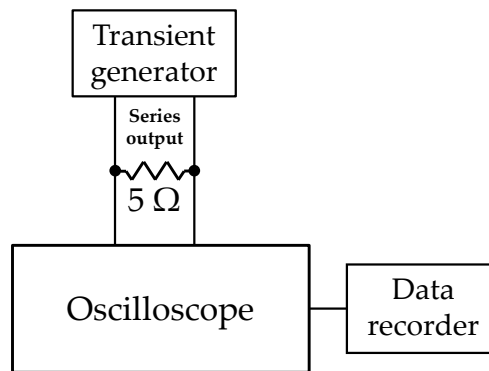

ECSS-E-ST-20-07_0080253

Figure 5-21: CS_z power leads, [differential mode](#) transients, calibration setup

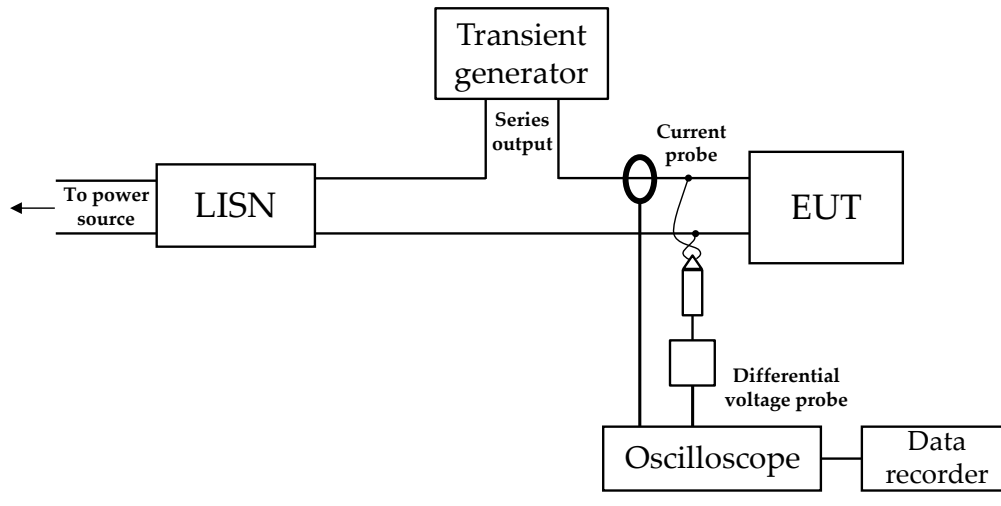

ECSS-E-ST-20-07_0080254

Figure 5-22: CS₂ power leads, differential mode transients, injection setup

ECSS-E-ST-20-07_0080255

Figure 5-23: <<deleted>>

ECSS-E-ST-20-07_00xxxxx

b. The test setup for the common mode transient shall be as follows:

1. Maintain a basic test setup for the EUT as specified in 5.2.6 and Figure 5-3.
2. For calibration:
 - (a) Configure the test equipment in accordance with Figure 5-24 for verification of the waveform.
 - (b) Set up the oscilloscope to monitor the voltage across the 5 Ω resistor.
3. For EUT testing, configure the test equipment as shown in Figure 5-25.

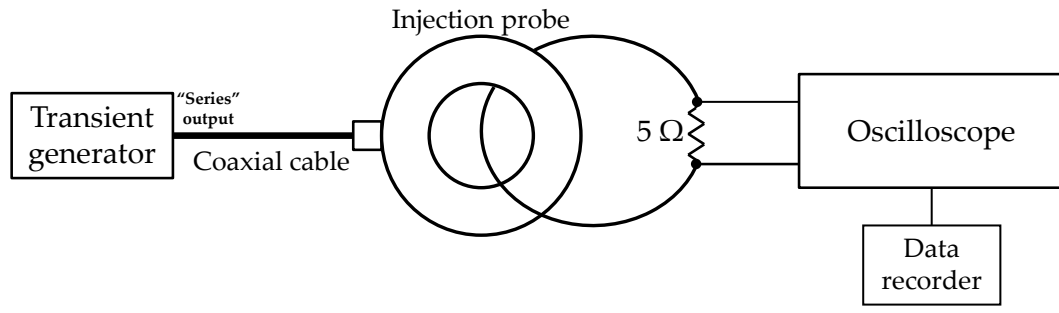

[ECSS-E-ST-20-07_00xxxxx](#)

Figure 5-24: CS, power leads, common mode transients, calibration setup

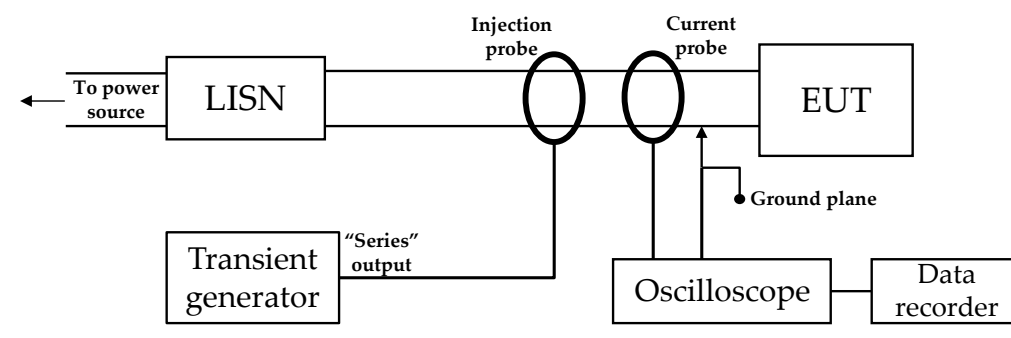

[ECSS-E-ST-20-07_00xxxxx](#)

Figure 5-25: CS, power leads, common mode transients, probe injection setup

5.4.9.4 Procedures

[ECSS-E-ST-20-07_0080210](#)

- a. The test procedures [for both differential mode and common mode transients](#) shall be as follows:
 1. Turn on the measurement equipment and wait until it is stabilized.
 2. Perform the following procedure using the calibration setup:
 - (a) Adjust the pulse generator for the pulse width, and pulse repetition rate.
 - (b) Adjust the amplitude of the signal to the level specified in associated limit.
 - (c) Verify that the waveform complies with the requirements, if not, correct accordingly.
 - (d) Record the pulse generator amplitude setting.
 - [\(e\) Record oscilloscope plots of the voltage transients.](#)
 3. Test the EUT by performing the following procedure using the test setup:
 - (a) Turn on the EUT and wait until it is stabilized.

- (b) Adjust the [transient](#) generator to a pulse duration.
- (c) Apply the test signal to each power [interface](#) and increase the generator output level to provide the specified voltage without exceeding the pulsed amplitude setting recorded during calibration.
- (d) Apply repetitive (6 to 10 pulses per second) positive [transients](#) to the EUT ungrounded input lines for a period not less than 2 minutes in duration, and if the equipment employ gated circuitry, trigger the spike to occur within the time frame of the gate.
- (e) Repeat 5.4.9.4a.3(d) with negative [transients](#).
- (f) Monitor the EUT for [signs of susceptibility](#).
- (g) If susceptibility is noted, determine the threshold level in accordance with 5.2.10.3 and verify that it is above the specified requirements.
- (h) Record oscilloscope [plots of the voltage and current transients](#).
- (i) Repeat 5.4.9.4a.3(b) through 5.4.9.4a.3(h) on each power [interface](#).

5.4.10 RS, magnetic field, 30 Hz to 100 kHz

5.4.10.1 Purpose

This test procedure is used to verify the ability of the EUT to withstand radiated magnetic fields.

5.4.10.2 Test equipment

ECSS-E-ST-20-07_0080211

- a. The test equipment shall be as follows:
 - 1. Signal source,
 - 2. Power amplifier,
 - 3. Radiating loop having the following specifications:
 - (a) Diameter: 12 cm
 - (b) Number of turns: 20
 - (c) Wire: N°12 AWG, insulated copper
 - (d) Magnetic flux density: $9,5 \times 10^7$ pT/A of applied current at a distance of 5 cm from the plane of the loop.
 - 4. Loop sensor having the following specifications:
 - (a) Diameter: 4 cm
 - (b) Number of turns: 51

- (c) Wire: 7-41 Litz wire (7 strands, N°41 AWG)
 - (d) Shielding: electrostatic
 - (e) Correction Factor: manufacturer's data for factors to convert measurement receiver readings to decibels above one picotesla (dBpT)
5. Measurement receiver,
 6. Calibration fixture: coaxial transmission line with 50 Ω characteristic impedance, coaxial connections on both ends, and space for a current probe around the centre,
 7. Current probe,
 8. LISN.

5.4.10.3 Setup

ECSS-E-ST-20-07_0080212

- a. The test setup shall be as follows:
 1. Maintain a basic test setup for the EUT as specified in Figure 5-3 and 5.2.6.
 2. Check the measurement system by configuring the measurement equipment, the radiating loop, and the loop sensor as shown in Figure 5-26.
 3. Test the EUT by configuring the test setup as shown in Figure 5-27.

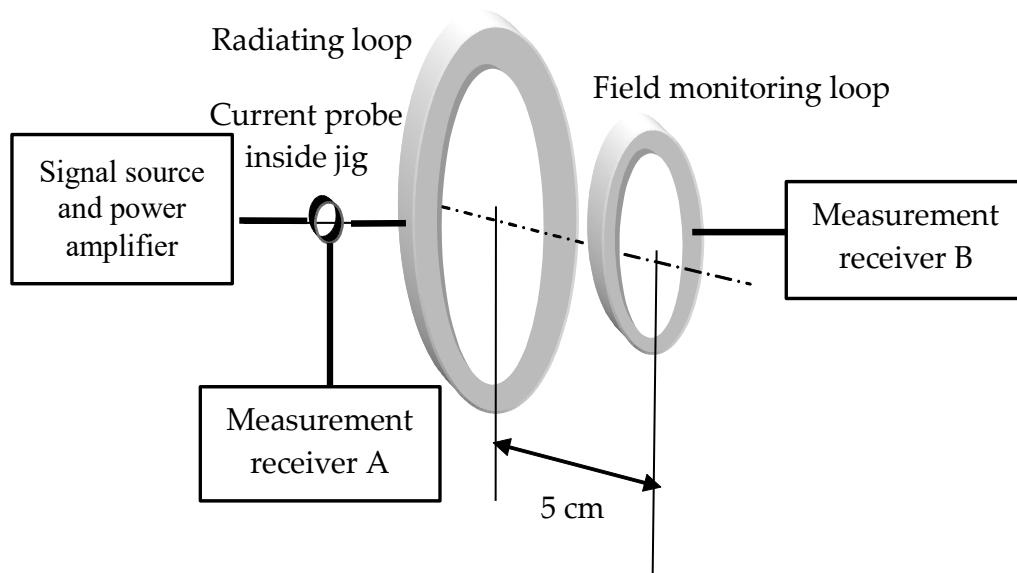

ECSS-E-ST-20-07_0080256

Figure 5-26: Measurement system check configuration of the radiating system

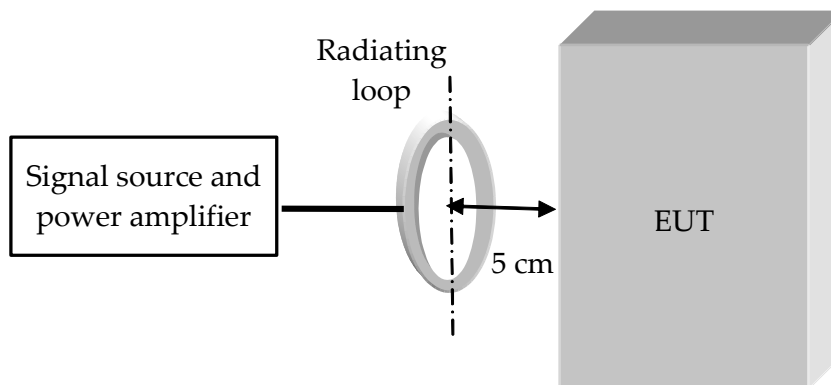

ECSS-E-ST-20-07_0080257

Figure 5-27: Basic test setup

5.4.10.4 Test procedures

ECSS-E-ST-20-07_0080213

- a. The measurement equipment shall be turned on and [sufficient time allowed for its stabilisation](#).

ECSS-E-ST-20-07_0080214

- b. The following procedure shall be performed using the calibration setup for verification of levels.
 1. Set the signal source to a frequency of 1 kHz and adjust the output to provide a magnetic flux density of 110 dBpT as determined by the reading obtained on measurement receiver A and the relationship given in 5.4.10.2a.3(d).
 2. Measure the voltage output from the loop sensor using measurement receiver B.
 3. Verify that the output on measurement receiver B is within ± 3 dB of the expected value based on the antenna factor and record this value.

ECSS-E-ST-20-07_0080215

- c. The EUT shall be tested by performing the following procedures for determination of location and level of susceptibility.
 1. Turn on the EUT and wait until it is stabilized.
 2. Select test frequencies as follows:

- (a) Locate the loop sensor 5 cm from the EUT face or electrical interface connector being probed and orient the plane of the loop sensor parallel to the EUT faces and parallel to the axis of connectors.
 - (b) Supply the loop with such a current to produce magnetic field strengths at least 10 dB greater than the limit specified by application of clause 4.2.8 but not to exceed 15 A (183 dBpT).
 - (c) Scan the frequency range.
 - (d) If susceptibility is noted, select no less than three test frequencies per octave at those frequencies where the maximum indications of susceptibility are present.
 - (e) Reposition the loop successively to a location in each 30 by 30 cm area on each face of the EUT and at each electrical interface connector, and repeat 5.4.10.4c.2(c) and 5.4.10.4c.2(d) to determine locations and frequencies of susceptibility.
 - (f) From the total frequency data where susceptibility was noted in 5.4.10.4c.2(c) through 5.4.10.4c.2(e), select three frequencies per octave over the frequency range.
3. At each frequency determined in 5.4.10.4c.2(f) apply a current to the radiating loop that corresponds to the specified limit, move the loop to search for possible locations of susceptibility without omitting the locations determined in 5.4.10.4c.2(e) while maintaining the loop 5 cm from the EUT surface or connector, and verify that susceptibility is not present.

5.4.10.5 Data Presentation

ECSS-E-ST-20-07_0080216

- a. In addition to 5.2.10.4, data presentation shall provide:
 1. Tabular data showing verification of the radiating loop in 5.4.10.4b.
 2. Tabular data, diagrams, or photographs showing the locations and test frequencies determined in 5.4.10.4c.2(e) and 5.4.10.4c.2(f).

5.4.11 RS, electric field, 30 MHz to 18 GHz

5.4.11.1 Purpose and overview

This test procedure is used to verify the ability of the EUT and associated cabling to withstand electric fields between 30 MHz and 18 GHz.

The specified method is a substitution method. The electric field level from the test antenna is first calibrated, unmodulated, using an electric field sensor set at the various test locations, in the absence of the EUT.

Then the EUT is installed and tested by replaying the same forward power to the test antenna as recorded during the calibration; this time with the modulation applied.

NOTE Additional requirements can apply beyond 18 GHz if SHF or EHF payloads are present. These are beyond the scope of the present standard.

5.4.11.2 Test equipment

ECSS-E-ST-20-07_0080217

a. The test equipment shall be as follows:

1. RF signal generators,
2. RF power amplifiers,
3. Linearly polarized transmit antennas
4. Three-axis isotropic electric field sensors (physically small - electrically short) with appropriate frequency response to cover the wanted test frequency range,
5. Measurement receiver,
6. Power meter,
7. Directional coupler,
8. Attenuator,
9. Data recording device,
10. LISN defined in 5.2.4.

NOTE 1 to item 5.4.11.2a.3: The following antennas are commonly used:

- 30 MHz to 200 MHz, biconical, 137 cm tip to tip,
- 200 MHz to 1 GHz, double ridge horn, 69,0 cm by 94,5 cm opening, or log-periodic,
- 1 GHz to 18 GHz, double ridge horn, 24,2 cm by 13,6 cm opening.

NOTE 2 to item 5.4.11.2a.10: The LISN is providing a defined common mode impedance.

ECSS-E-ST-20-07_00xxxxx

b. No LISN need be used if the primary power lines are shielded in the actual installation of the relevant space segment element and in the test setup.

5.4.11.3 Test setup

ECSS-E-ST-20-07_0080218

a. A basic test setup shall be maintained for the EUT as shown and specified in 5.2.6. and Figure 5-3.

ECSS-E-ST-20-07_0080219

b. <<deleted>>

ECSS-E-ST-20-07_0080220

c. <<deleted>>.

ECSS-E-ST-20-07_0080221

d. For the calibration of the electric field, performed in the absence of the EUT, LISN and test harness, the setup, illustrated in Figure 5-29, shall be as follows:1. Place the transmit antenna at each of the positions planned for EUT testing, as specified in 5.4.11.3e.2. Place the electric field sensor directly opposite the transmit antenna as shown in Figure 5-30 at 30 cm above the ground plane.

ECSS-E-ST-20-07_0080222

e. For testing the EUT, the transmit antennas shall be placed 1 m or more from the test setup boundary as follows:

1. 30 MHz to 200 MHz

(a) For test setup boundaries ≤ 3 m (including all enclosures of the EUT and the 2 m of exposed interconnecting and power leads specified in 5.2.6.6.), centre the antenna between the edges of the test setup boundary, ensuring that the interconnecting leads represent the actual platform installation and are shorter than 2 m.(b) For test setup boundaries > 3 m, use multiple antenna positions (N) at spacings as specified in Figure 5-30, where the number of antenna positions (N) is determined by dividing the edge-to-edge boundary distance (in metres) by 3 and rounding up to an integer.2. 200 MHz and above, use multiple antenna positions (N) as shown in Figure 5-30, where the number of antenna positions (N) is determined as follows:

(a) For testing from 200 MHz up to 1 GHz, place the antenna in a number of positions such that the entire width of each EUT enclosure and the first 35 cm of cables and leads interfacing with the EUT enclosure are within the 3 dB beamwidth of the antenna

(b) For testing at 1 GHz and above, place the antenna in a number of positions such that the entire width of each EUT enclosure and the first 7 cm of cables and leads interfacing with the EUT enclosure are within the 3 dB beamwidth of the antenna.

ECSS-E-ST-20-07_0080223

- f. For testing the EUT, the placement of electric field sensors shall be maintained as specified in 5.4.11.3d.1.

ECSS-E-ST-20-07_0080258

Figure 5-28: <<deleted>>

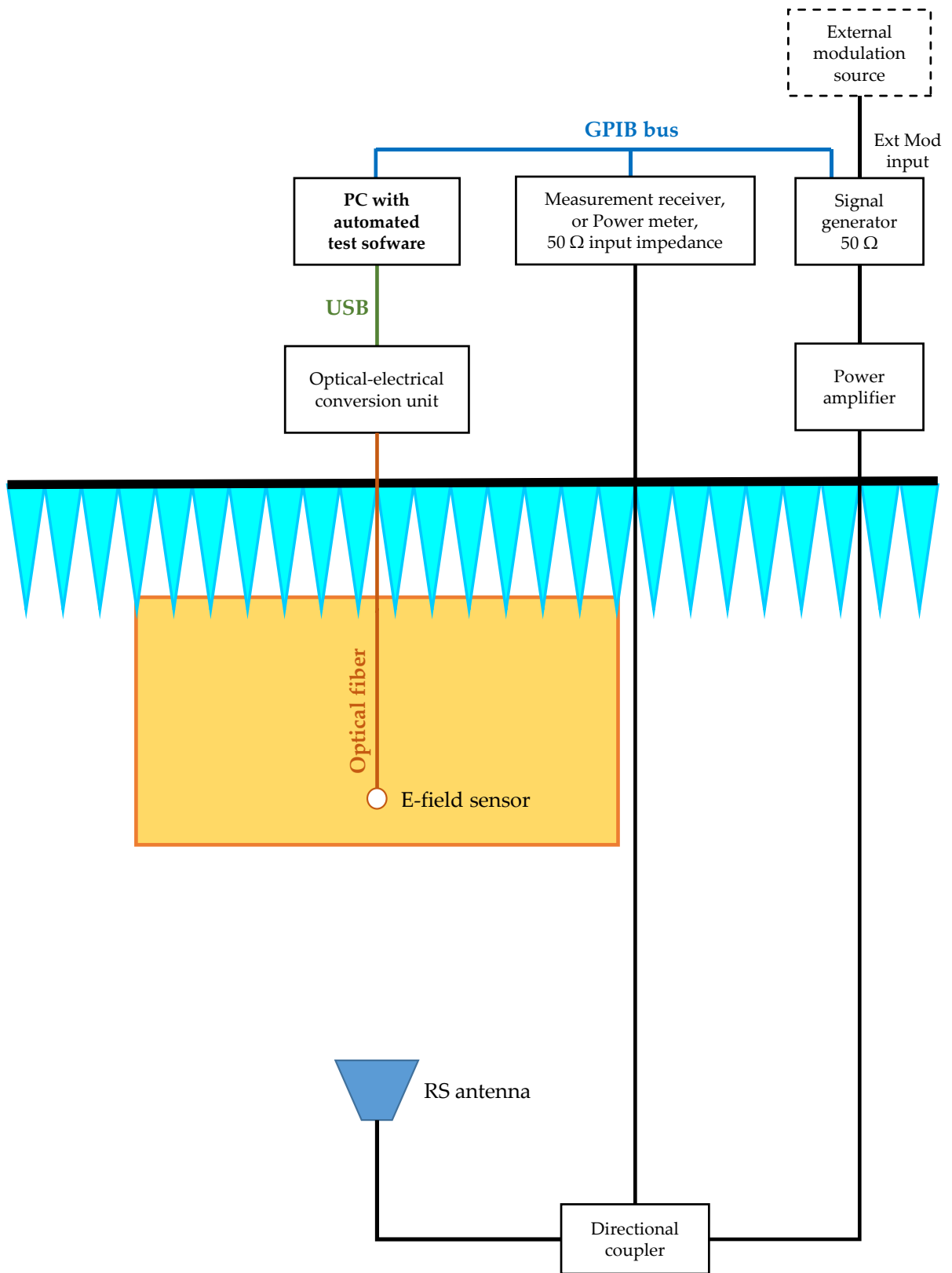

ECSS-E-ST-20-07 00xxxxx

Figure 5-29: Example of electric field calibration test setup

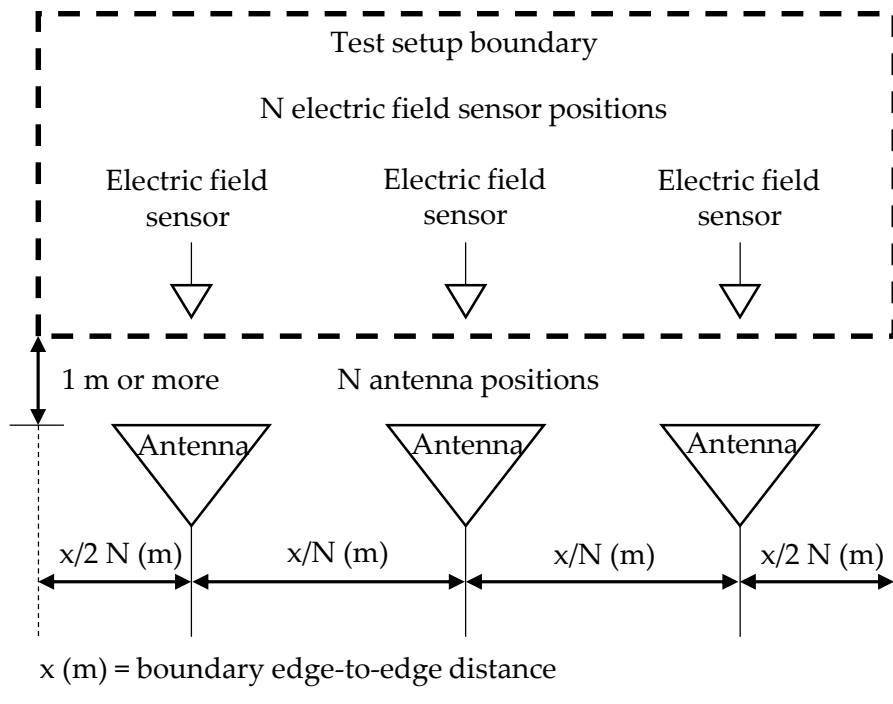

ECSS-E-ST-20-07_0080259

Figure 5-30: RS Electric field – Multiple test antenna positions

ECSS-E-ST-20-07_0080260

Figure 5-31: <<deleted>>

5.4.11.4 Test procedures

ECSS-E-ST-20-07_0080224

- a. Assess the test area for potential RF hazards and take necessary precautionary steps to assure safety of test personnel and fire avoidance.

ECSS-E-ST-20-07_0080225

- b. The calibration of the electric field shall be performed as follows:
 1. Turn on the EMC test equipment and allow sufficient time for its stabilisation.
 2. Adjust the band and gain settings of the RF power amplifier chosen to test the first frequency band.
 3. Using the signal generator and transmit antenna chosen to test the first frequency band, the transmit antenna being vertically polarised, establish a low-level unmodulated electric field at the first test frequency, measured by the E-field sensor.

4. Gradually increase the signal-generator output-power until the electric field level measured by the electric field sensor reaches the level specified by application of clause 4.2.8.
5. Record the forward power to the test antenna, as measured by the measurement receiver or by the power meter, and the output power of the signal generator.
6. Repeat 5.4.11.4b.3 to 5.4.11.4b.5 for each frequency testable with the same signal-generator – amplifier – transmit antenna chain.
7. Repeat 5.4.11.4b.3 to 5.4.11.4b.6 for the horizontal polarisation.
8. Repeat 5.4.11.4b.3 to 5.4.11.4b.7 for each test antenna position determined in 5.4.11.3e.
9. Repeat 5.4.11.4b.2 to 5.4.11.4b.8 for each signal-generator – amplifier – transmit-antenna chain.

NOTE The ground plane tends to short-circuit horizontally polarized fields, so that more power is needed to achieve the same field value in horizontal polarization as in vertical polarization.

ECSS-E-ST-20-07_0080226

- c. If a measurement receiver is used, the EUT shall be tested as follows:
1. Turn on the EMC test equipment and the EUT and allow sufficient time for their stabilisation.
 2. Adjust the band and gain settings of the RF power amplifier chosen to test the first frequency band.
 3. Using the transmit antenna chosen to test the first frequency band vertically polarised, set the unmodulated signal generator to the first test frequency, at low output power level.
 4. Adjust and apply the signal modulation specified in 5.2.10.2.
 5. Increase the signal generator output power level until the forward power level to the transmit antenna, as determined during calibration is met.
 6. Maintain the signal during the dwell time specified in 5.2.10.1.
 7. Monitor the EUT for signs of susceptibility.
 8. Record, for information only, the electric field level measured by the isotropic field probe, as a confirmation that an electric field was actually applied.
 9. If susceptibility is noted, determine the threshold level in accordance with 5.2.10.3.
 10. Repeat 5.4.11.4c.3 to 5.4.11.4c.9 for each frequency testable with the same signal-generator – amplifier – transmit-antenna chain.
 11. Repeat 5.4.11.4c.3 to 5.4.11.4c.10 for the horizontal polarisation.

12. Repeat 5.4.11.4c.3 to 5.4.11.4c.11 for each test antenna position determined in 5.4.11.3e.
13. Repeat 5.4.11.4c.2 to 5.4.11.4c.12 for each signal-generator – amplifier – transmit antenna chain.

NOTE To item 5.4.11.4c.8: The electric field level measured by the isotropic probe with the EUT present and with the modulation applied is in practice significantly different from the calibrated electric field level, so is only useful for direct confirmation that an electric field is actually present.

d. If a power meter is used, the EUT shall be tested as follows:

1. Turn on the EMC test equipment and the EUT and allow sufficient time for their stabilisation.
2. Adjust the band and gain settings of the RF power amplifier chosen to test the first frequency band.
3. Using the transmit antenna chosen to test the first frequency band vertically polarised, set the unmodulated signal generator to the first test frequency, at low output power level.
4. Increase the signal generator output power level until the forward power level to the transmit antenna, as determined during calibration is met.
5. Adjust and apply the signal modulation specified in 5.2.10.2.
6. Maintain the signal during the dwell time specified in 5.2.10.1.
7. Monitor the EUT for signs of susceptibility.
8. Record, for information only, the electric field level measured by the isotropic field probe, as a confirmation that an electric field was actually applied.
9. If susceptibility is noted, determine the threshold level in accordance with 5.2.10.3.
10. Repeat 5.4.11.4d.3 to 5.4.11.4d.9 for each frequency testable with the same signal-generator – amplifier – transmit-antenna chain.
11. Repeat 5.4.11.4d.3 to 5.4.11.4d.10 for the horizontal polarisation.
12. Repeat 5.4.11.4d.3 to 5.4.11.4d.11 for each test antenna position determined in 5.4.11.3e.
13. Repeat 5.4.11.4d.2 to 5.4.11.4d.12 for each signal-generator – amplifier – transmit antenna chain.

NOTE To 5.4.11.4d.8: The electric field level measured by the isotropic probe with the EUT present and with the modulation applied is in practice significantly different from the calibrated electric field level, so is only useful for direct confirmation that an electric field is actually present.

5.4.11.5 Test report content and data presentation

ECSS-E-ST-20-07_0080227

- a. In addition to 5.2.10.4, the test report shall include a graphical or tabular representation of generator level, forward power to the transmit antenna, required field strength and calculated applied field strength according to the frequency.

ECSS-E-ST-20-07_00xxxxx

- b. In addition to 5.2.10.4, data presentation may provide graphical or tabular representation of recorded calibration data.

5.4.12 Susceptibility to wire-coupled electrostatic discharges (legacy method)

5.4.12.1 Overview

Two different categories of ESD test methods as described in this standard (coupling to cable bundles as in 5.4.12 or 5.4.13 and direct injection into chassis as in 5.4.14), with different coupling paths, result in a better test coverage and experience showed that they are complementary to spot weak designs.

The purpose of this test is to verify the immunity to the electromagnetic effects of electrostatic discharges wire-coupled to the cable bundles connected to the EUT.

5.4.12.2 Test equipment

ECSS-E-ST-20-07_0080228

- a. The test equipment shall be as follows:
1. DC high voltage supply or an ESD generator as specified in IEC 61000-4-2 (Edition 1.2).
 2. The discharge primary circuit is constituted of:
 - (a) 6 kV spark gap,
 - (b) 100 pF capacitance, high-voltage capacitor with inductance less than 20 nH,
 - (c) 47 Ω damping resistor (high voltage specification),
 - (d) 10 k Ω resistors (high voltage specification).
 - (e) Coupling wire, comprising a 20 cm long straight section and some extra length for connection to the rest of the circuit.
 3. Monitoring devices:
 - (a) One or two passive current probes, 100 A peak capability and ≥ 500 MHz bandwidth,
 - (b) One high-voltage probe, 10 kV range, 1 MHz bandwidth,

- (c) One two-channel digital oscilloscope with pre-triggering capability and ≥ 500 MHz analogue bandwidth.

NOTE 1 5.4.12.2a.1: Use of the ESD generator is less hazardous than use of the DC high voltage supply for test operators.

NOTE 2 5.4.12.2a.2(a): An air spark gap or an overvoltage suppressor in a sealed pressurized envelop can be used.

NOTE 3 5.4.12.2a.2(a): An air spark gap is less stable and has longer rise time.

NOTE 4 to item 5.4.12.2a.2(c): The value can be adjusted at critical damping depending on value of capacitance C and self-inductance of the discharge circuit.

NOTE 5 to item 5.4.12.2a.2(d): Choke resistors prevent high-frequency components of discharge from flowing in uncontrolled paths so the discharge parameters are not dependent on length and position of high-voltage source wires.

NOTE 6 to item 5.4.12.2a.3(b): If the probe input impedance is not high enough, it can prevent gap arcing by lowering the available voltage.

NOTE 7 to item 5.4.12.2a.3(c): Typical values are 20 ns pre-trigger time, 10 ns per division as a starting point.

5.4.12.3 Setup

ECSS-E-ST-20-07_0080229

- a. The test setup shall be as follows:
1. Maintain a basic test setup for the EUT as specified in 5.2.6 and Figure 5-3.
 2. When using an ESD generator as a high-voltage power supply as shown Figure 5-33 or Figure 5-34, it is set in the contact discharge mode.
 3. Connect the high-voltage electrode to the discharge circuit at the node between the spark gap and the capacitor.
 4. The discharge circuit length is not larger than what is necessary to place in series the 20 cm long straight section of the coupling wire, the damping resistor, the discharge capacitor, the spark gap and the current probe.
 5. For calibration the test equipment is configured as shown Figure 5-33, and meeting following provisions:
 - (a) the discharge circuit is not coupled to the EUT,
 - (b) choke resistors are near the capacitor,
 - (c) the current probe monitoring the primary current from the ESD source is near the damping resistor, at the capacitor side,

- (d) the high voltage probe is measuring the voltage across the capacitor, grounded at the damping resistor side.
- 6. Test the EUT by configuring the test equipment as specified in Figure 5-34 and meeting the following provisions:
 - (a) the high voltage probe used for calibration is removed,
 - (b) the EUT is mounted on a conductive ground plane using the space vehicle mount and attach points.
 - (c) the discharge circuit is supported 5 cm above the ground plane by a non-conductive standoff with high-voltage insulation capability,
 - (d) from calibration, the discharge circuit is kept unchanged in size and shape, and the coupling wire directly attached, by non-metallic bonds, over 20 cm along an EUT bundle,
 - (e) a current probe is monitoring the primary current from the ESD source near the damping resistor,
 - (f) an optional second current probe is monitoring the current in the EUT harness, 5 cm from the EUT connector.

NOTE 1 to item 5.4.12.3a.1: It is important at this point to assess the test area for potential high-voltage hazards and take necessary precautionary steps to assure safety of test personnel.

NOTE 2 To item 5.4.12.3a.4: It is important to ensure that the discharge loop is as small as possible for achieving the transient pulse duration objective defined in 5.4.12.4a.2(d).

NOTE 3 to item 5.4.12.3a.5: The high-voltage probe is not meant to measure the voltage during the discharge but the voltage reached before discharge.

NOTE 4 to item 5.4.12.3a.6: It is preferable to use the actual electrical harness.

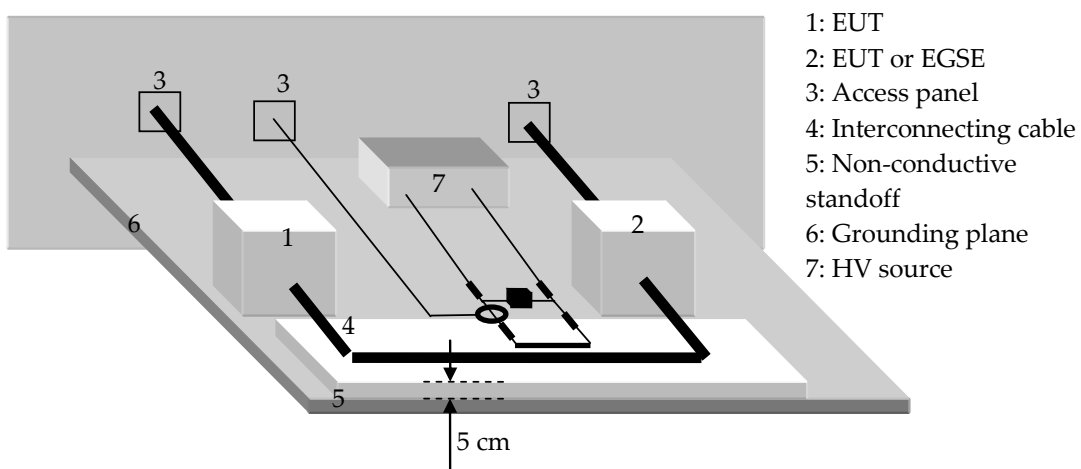
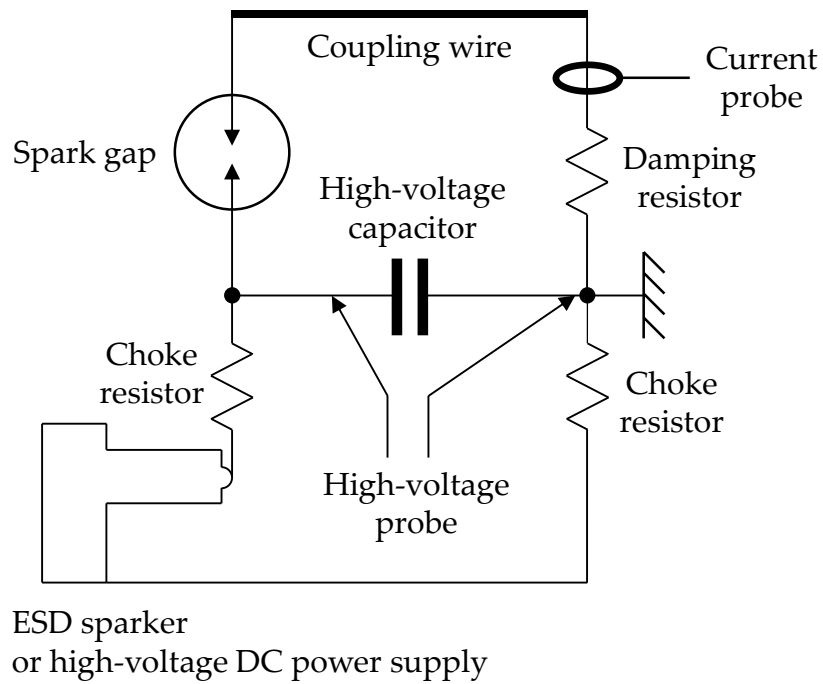
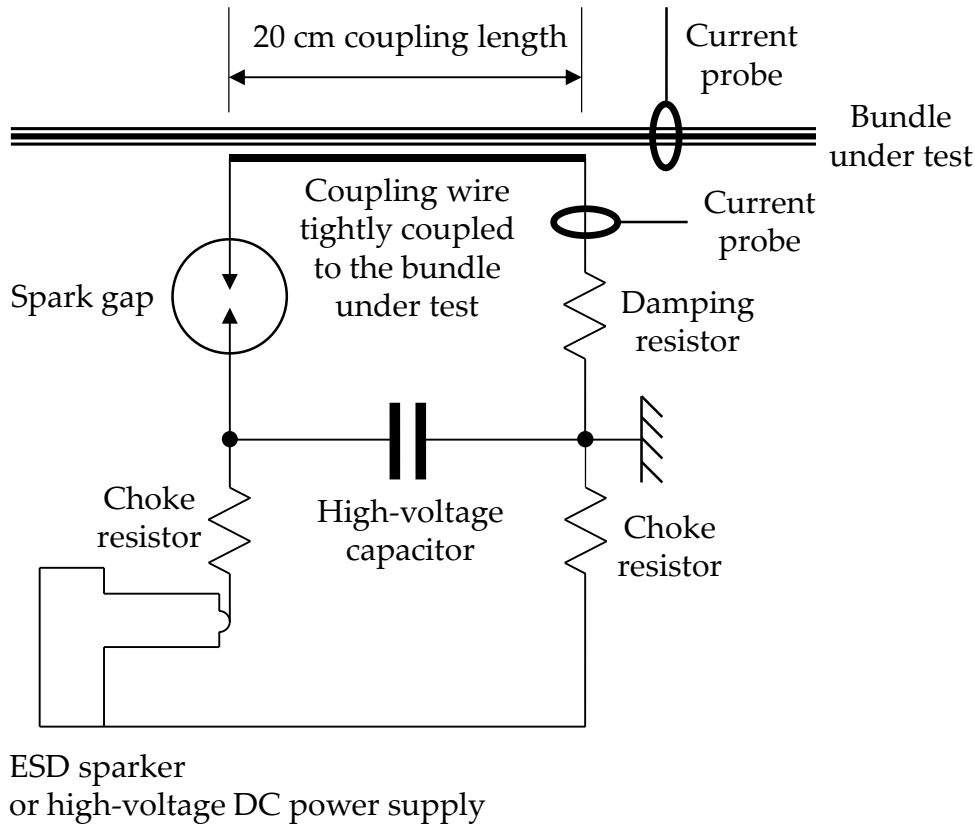

Figure 5-32: Spacecraft charging ESD susceptibility test



ECSS-E-ST-20-07_0080261

Figure 5-33: Susceptibility to ESD: calibration configuration



ECSS-E-ST-20-07_0080262

Figure 5-34: Susceptibility to ESD: test equipment configuration

5.4.12.4 Procedure

ECSS-E-ST-20-07_0080230

- a. The test procedures shall be as follows:
 1. Turn on the measurement equipment and wait until it is stabilized.
 2. Perform a calibration using the calibration setup:
 - (a) Select the spark gap device or adjust the spark length at the voltage breakdown to be used for the test,
 - (b) Turn on the high voltage generator,
 - (c) Using the high voltage probe, check the breakdown voltage value is stable and within $\pm 30\%$ from the value to be used for the test.
 - (d) Monitor the transient current pulse and verify that the following discharge current parameters are met: peak amplitude ≥ 30 A, duration at 15 A height ≥ 20 ns, rise time ≤ 5 ns, as illustrated in Figure 5-35.
 - (e) Record the last current and voltage couple, displayed with a common time reference,

- (f) Repeat 5.4.12.4a.2(d) and 5.4.12.4a.2(e) with opposite polarity.
- 3. Test the EUT as follows:
 - (a) Fully power the unit during the complete ESD test,
 - (b) Turn on the high voltage generator,
 - (c) Establish a pulse discharge at a pulse rate of 1 Hz, with a pulse direction of at least 15 positive and 15 negative,
 - (d) Monitor the EUT for signs of susceptibility.
 - (e) Record the primary and optionally secondary current couple, displayed with a common time reference,
 - (f) Repeat 5.4.12.4a.3(c) and 5.4.12.4a.3(e) on each bundle interfacing with each electrical connector.

NOTE To item 5.4.12.4a.2(d): Means for minimizing the rise time are adjusting the damping resistor, reducing the size loop, checking that both choke resistors are as close as possible to the capacitor, and technology of the spark gap (nature of gas and shape of electrodes).

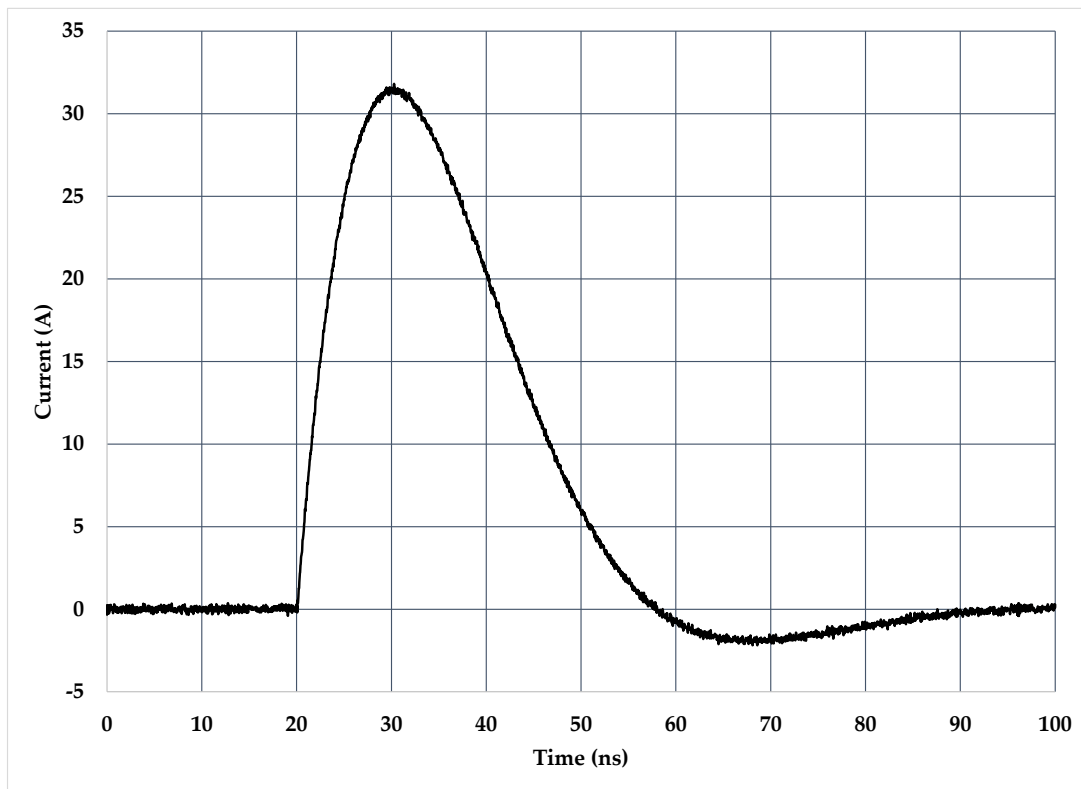

Figure 5-35: Example of compliant discharge current shape

5.4.12.5 Data presentation

ECSS-E-ST-20-07_0080231

- a. Superseding clause 5.2.10.4, data presentation shall be as follows:

1. Provide tables showing statements of compliance with the requirement and the induced current level for each interface connector.
2. Provide oscilloscope records taken during calibration and EUT testing procedures.
3. The requirement of 5.2.10.3 does not apply.

5.4.13 Susceptibility to wire-coupled electrostatic discharges (current injection probe method)

5.4.13.1 Overview

Two different categories of ESD test methods as described in this standard (coupling to cable bundles as in 5.4.12 or 5.4.13 and direct injection into chassis as in 5.4.14), with different coupling paths, result in a better test coverage and experience showed that they are complementary to spot weak designs.

The purpose of this test is to verify the immunity to the electromagnetic effects of wire-coupled electrostatic discharges. It is an improvement over the test method described in 5.4.12, with fewer factors influencing the test waveform and the coupling to the bundle under test. This test method is preferred as an alternative to the one described in 5.4.12.

5.4.13.2 Test equipment

ECSS-E-ST-20-07 0080xxx

- a. The test equipment shall be as follows:
 1. Dedicated ESD pulse generator, designed for the current injection probe method.
 2. Coaxial cable: 50 Ω characteristic impedance.
 3. BCI current probe: 30A peak capability, with a flat frequency response at least from $F_{\min-3dB} = 7,5$ MHz to $F_{\max-3dB} = 400$ MHz.
 4. Calibration fixture adapted to the BCI probe.
 5. Digital oscilloscope: 50 Ω input impedance, minimum 500 MHz bandwidth, 5 GSa/s
 6. Attenuators amounting to a total of 60 dB, 30 A peak capability for the first one in the chain, minimum 500 MHz bandwidth, 50 Ω ,
 7. Coaxial loads: 50 Ω , 30 A peak capability (if used without attenuator)
 8. Current probe: 30 A peak capability with flat frequency response at least from $F_{\min-3dB} = 7,5$ MHz to $F_{\max-3dB} = 400$ MHz.

5.4.13.3 Calibration

ECSS-E-ST-20-07 0080xxx

- a. The calibration setup shall be established as specified in Figure 5-36.

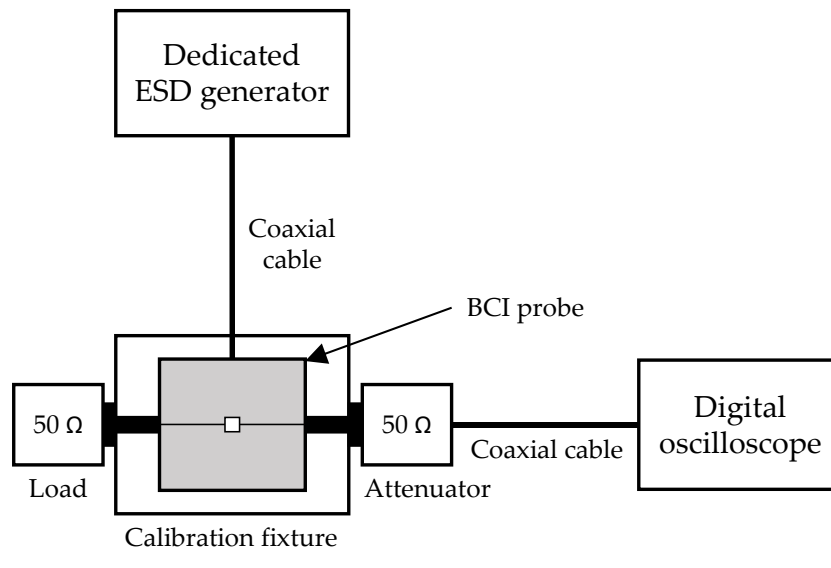

[ECSS-E-ST-20-07 0080xxx](#)

Figure 5-36: Test setup for calibration of test waveform

[ECSS-E-ST-20-07 0080xxx](#)

b. The calibration shall be performed as follows:

1. Turn on the measurement equipment and wait until it is stabilized,
2. Turn on the dedicated ESD pulse generator,
3. Starting from 3 kV, adjust the amplitude of the charging voltage of the pulse generator until the waveform is within the following ranges, also illustrated in Figure 5-37:
 - (a) amplitude: 13 A ± 1 A
 - (b) rise time: 1,5 ns ± 0,3 ns, measured between 10% and 90% of the peak amplitude
 - (c) duration: 3 ns ± 1 ns at 50% amplitude
4. Record the pulse generator settings,
5. Record the last transient current pulse measured by the oscilloscope.

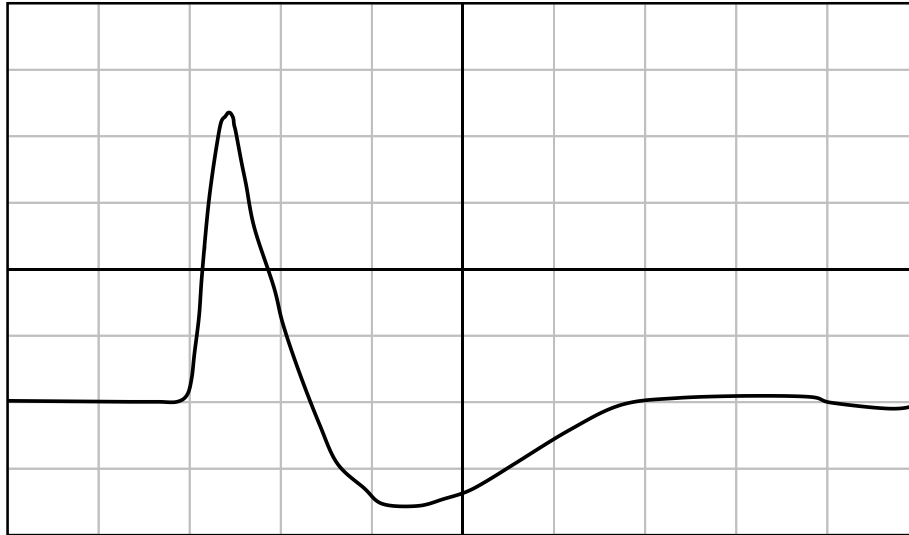

ECSS-E-ST-20-07 0080xxx

Figure 5-37: Typical ESD pulse measured during calibration (3 A/div, 4 ns/div)

5.4.13.4 EUT testing

ECSS-E-ST-20-07 0080xxx

a. The test setup for EUT testing, illustrated in Figure 5-38, shall be as follows:

1. Basic test setup for the EUT as specified in 5.2.6 and Figure 5-3,
2. Injection and monitor probes placed around a cable bundle interfacing an EUT connector,
3. Monitor probe positioned at 5 cm from the EUT connector, or as close to the connector backshell as possible in case the overall length of the connector and backshell exceeds 5 cm,
4. Injection probe positioned at 5 cm from the monitor probe.

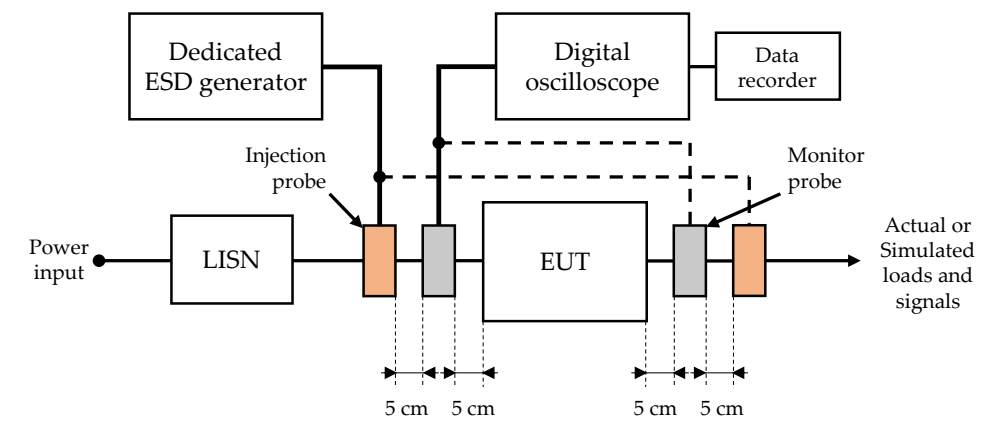

ECSS-E-ST-20-07 0080xxx

Figure 5-38: Wire-coupled ESD test setup (current injection probe method)

ECSS-E-ST-20-07 0080xxx

b. The test procedure shall be as follows:

1. Turn on the EUT and wait until it is stabilized,
2. Record the EUT nominal functional parameters before the pulse injections,
3. With the generator settings used during the calibration, inject at least 15 pulses; at a pulse repetition rate between 0,5 Hz and 2 Hz, while monitoring the EUT for signs of susceptibility,
4. Record the current pulse measured on the cable bundle under test,
5. Repeat 2 to 4 after clamping the BCI probe rotated by 180° in order to change the pulse polarity,
6. Repeat 2 to 5 on each cable bundle interfacing with an EUT connector.

5.4.13.5 Data presentation

ECSS-E-ST-20-07 0080xxx

a. Data presentation shall be as follows:

1. ESD generator settings,
2. Table stating compliance to the requirement,
3. Oscilloscope records taken during calibration,
4. Induced current level measured on each tested cable bundle.

5.4.14 Susceptibility to electrostatic discharges into the chassis

5.4.14.1 Overview

The purpose of this test is to verify the immunity to the electromagnetic effects of electrostatic discharges injected directly into the chassis.

Direct injection used to be the test method for representing replacement currents consecutive to an ESD occurring in flight (MIL-STD-1541A, Electromagnetic Compatibility Requirements for Space Systems, cancelled) before the introduction of the wire coupling method in Europe.

The method and level for the direct ESD specified in 5.4.14.4 are based on the IEC 61000-4-2 and on the MIL-STD-461G/CS118, which represent human body ESD. It is supposed to be also suitable to represent the replacement currents consecutive to an ESD occurring in flight.

Two different categories of ESD test methods (coupling to cable bundles as in 5.4.12 or 5.4.13 and direct injection into chassis as in 5.4.14), with different coupling paths, result in a better test coverage and experience showed that they are complementary to spot weak designs.

5.4.14.2 Test equipment

ECSS-E-ST-20-07 0080xxx

- a. The test equipment shall be as follows:
1. ESD generator as specified in the IEC 61000-4-2, with 150 pF capacitance and 330 Ω discharge resistance, and contact discharge tip.
 2. ESD current target, input resistance $2 \pm 5\% \Omega$, as specified in the IEC 61000-4-2.
 3. Attenuator, 20 dB.
 4. Coaxial cable, 50 Ω impedance, length ≤ 1 metre.
 5. Digital oscilloscope: 50 Ω input impedance, analogue bandwidth ≥ 1 GHz, real time sampling rate ≥ 5 GSa/s, with pre-triggering capability.

5.4.14.3 Test setup

ECSS-E-ST-20-07 0080xxx

- a. The test setup for EUT testing shall be as follows:
1. Basic test setup for the EUT as specified in 5.2.6 and Figure 5-3.
 2. ESD generator set in contact discharge mode.
 3. Length of the ground cable, used to connect the ESD generator to the metallic ground plane, of two metres.
 4. Tip of the discharge electrode held orthogonal to the surfaces under test.

NOTE to item 2: It means that the discharge is triggered by the closure of a relay inside the ESD generator (as opposed to the "air discharge" mode).

ECSS-E-ST-20-07 0080xxx

- b. During EUT testing, the ground cable shall stay at least 20 cm from the other test setup items: EUT, cables, LISN, EGSE.

ECSS-E-ST-20-07 0080xxx

- c. During EUT testing, the ground cable may pass close to the metallic ground plane.

ECSS-E-ST-20-07 0080xxx

- d. During EUT testing, no more than 20 cm of ground cable length shall lay on the surface of the ground plane.

5.4.14.4 Procedure

ECSS-E-ST-20-07 0080xxx

- a. The calibration shall be performed as follows:
1. Turn on the measurement equipment and allow sufficient time for stabilisation.
 2. Set up the ESD current target, attenuator and oscilloscope as specified in Figure 5-39.
 3. Set the ESD generator output voltage to 8 kV and to use the contact discharge mode.
 4. Place the tip of the ESD simulator in contact with the target and measure the waveform using the oscilloscope.
 5. Verify that the following discharge current parameters defined in Figure 5-40 are met:
 - (a) First peak amplitude = $30\text{ A} \pm 15\%$,
 - (b) $0,6\text{ ns} \leq \text{rise time} < 1,0\text{ ns}$, from 10% to 90% of the peak value of the current waveform.
 - (c) Current $I_1 = 16\text{ A} \pm 30\%$, at $t_1 = 30\text{ ns}$,
 - (d) Current $I_2 = 8\text{ A} \pm 30\%$, at $t_2 = 60\text{ ns}$,
 6. Record the current waveform for both positive and negative polarity discharges.

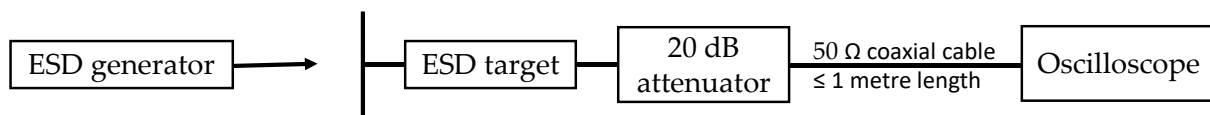

ECSS-E-ST-20-07 0080xxx

Figure 5-39: Discharge current verification setup

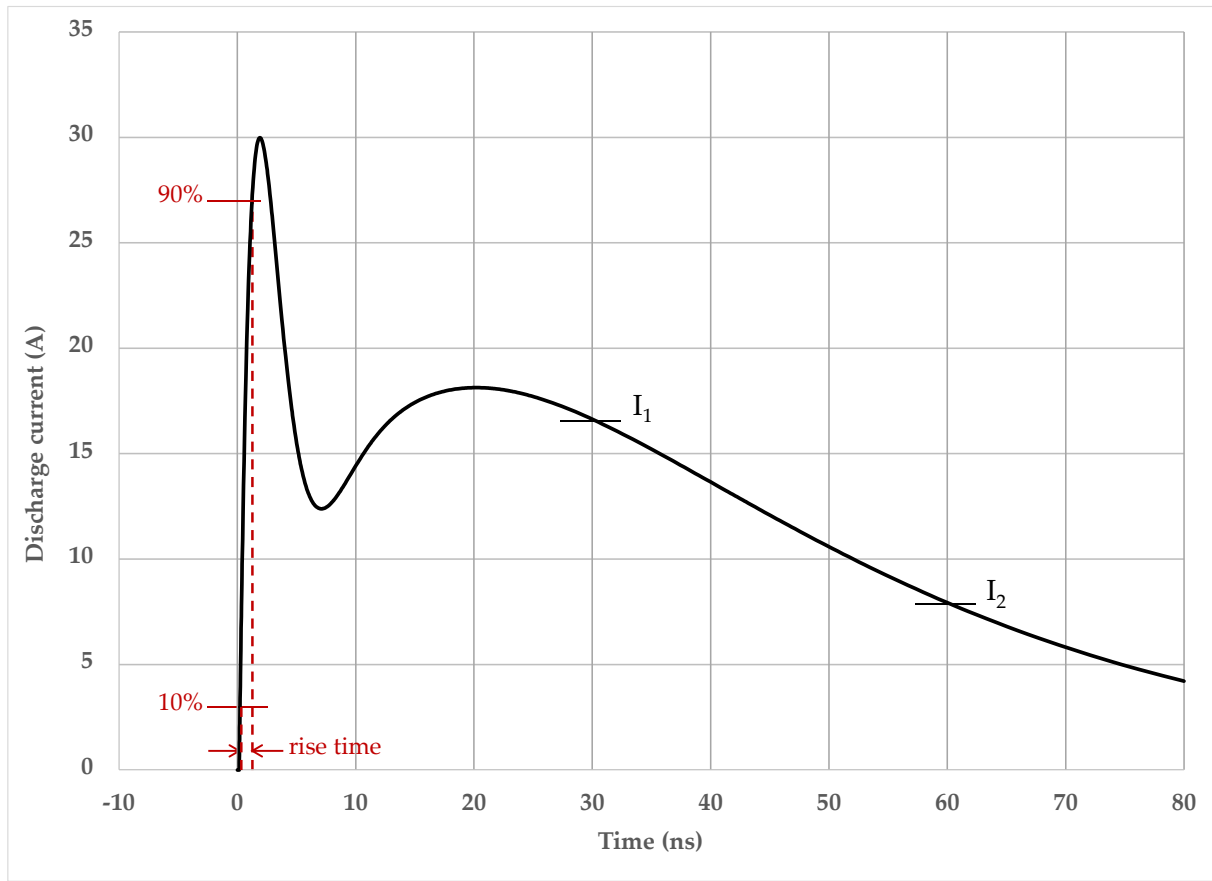

ECSS-E-ST-20-07 0080xxx

Figure 5-40: Ideal contact discharge current waveform at 8 kV

ECSS-E-ST-20-07 0080xxx

b. The calibration need not be performed before each ESD test campaign.

ECSS-E-ST-20-07 0080xxx

c. An ESD generator may be used that has been calibrated by a dedicated calibration service and is within calibration period.

ECSS-E-ST-20-07 0080xxx

d. The test shall be performed as follows:

1. Turn on the EUT and the measurement equipment and allow sufficient time for stabilisation,
2. Establish a pulse repetition rate between 0,5 Hz and 2 Hz on the ESD generator,
3. Inject the discharge into the unit structure for at least 10 predefined locations, near the box corners and near the connectors, within less than 2 cm,
4. Monitor the EUT for signs of susceptibility,

5. Maintain the injection for at least 30 seconds at each injection point with positive discharges.
6. Repeat the injection for at least 30 seconds at each injection point with negative discharges.

5.4.14.5 Data presentation

ECSS-E-ST-20-07 0080xxx

- a. Data presentation shall be as follows:
 1. ESD generator settings.
 2. Oscilloscope records taken during calibration.
 3. Table stating compliance to the requirements.

5.4.15 CE, power leads, time domain

5.4.15.1 Purpose

This method is used to measure the conducted emission on the power leads in the time domain. The emission is measured both as voltage between hot line and return and as current measured in any of the two lines. Both continuous emission, known as “ripple and spikes” and operational transients are measured.

5.4.15.2 Test equipment

ECSS-E-ST-20-07 0080xxx

- a. The test equipment shall be as follows:
 1. Differential voltage probe.
 2. Active current probe.
 3. Low-pass filter.
 4. Two-channel digital oscilloscope with 50 Ω inputs and pre-triggering capability.
 5. Data recording device.
 6. LISN defined in 5.2.4.

5.4.15.3 Test setup

ECSS-E-ST-20-07 0080xxx

- a. The test setup shall be as follows:
 1. Maintain a basic test setup for the EUT as specified in 5.2.6 and Figure 5-3.
 2. For equipment testing, configure the test setup as shown in Figure 5-41.

ECSS-E-ST-20-07 0080xxx

- b. The bandwidth shall be limited to a value between 20 MHz and 50 MHz, either by inserting a passive low-pass filter between the differential voltage probe and the oscilloscope, or by using the oscilloscope built-in bandwidth limitation setting.

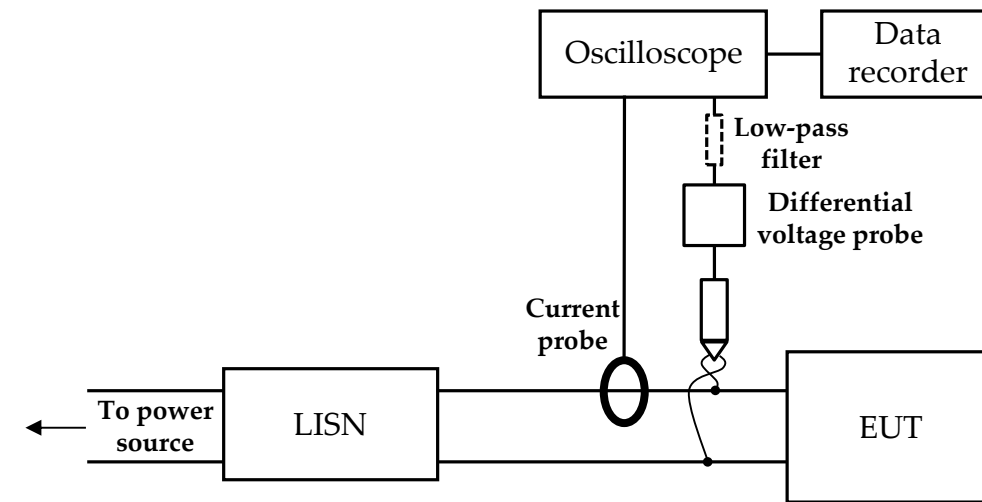

ECSS-E-ST-20-07 0080xxx

Figure 5-41: Conducted emission, power leads, time domain: measurement setup

5.4.15.4 Procedure

ECSS-E-ST-20-07 0080xxx

- a. For the measurement of continuous emission, the test procedure shall be as follows:
1. Turn on the measurement equipment and wait until it is stabilized,
 2. Turn on the EUT in its most emissive mode and wait for its stabilization,
 3. Search for and trigger on a repetitive pattern,
 4. Record the CE as both voltage and current.

ECSS-E-ST-20-07 0080xxx

- b. For the measurement of transient emission, the test procedure shall be as follows:
1. Turn on the measurement equipment and wait until it is stabilized,
 2. Turn on the EUT and wait for its stabilization,
 3. Activate the operational transients of the EUT.
 4. Record the transient emissions as both voltage and current.

NOTE A transient event would typically be a change of operational mod or the switch on/off of a load.

5.4.15.5 Data presentation

ECSS-E-ST-20-07_0080xxx

a. Data presentation shall be as follows:

1. Information of the bandwidth used, and whether it was obtained external filtering or via oscilloscope settings.
2. Oscilloscope plots.
3. Table stating compliance to the requirements.

Annex A (informative)

Subsystem and equipment limits

A.1 Overview

There is no single method for achieving EMC.

- Low susceptible equipment is for telecommunication spacecraft flying in a severe EMI environment due to on board large power and possible residual ESD.
- Low emission equipment is for scientific spacecraft for preserving high sensitivity of detectors.

Therefore, it is not possible to define a same set of limits for all equipments of all spacecraft and launchers. The EMCCP is the vehicle for tailoring limits and test methods.

However, it is a legitimate demand of equipment supplier to ask for EMI limits outside the frame of a specific project. Conducted and radiated emission limits and susceptibility limits defined hereafter are recommended for space projects.

A.2 CE on power leads, differential mode, 30 Hz to 100 MHz

In differential mode, on each independent power bus, conducted emissions on power leads, induced by loads, can be limited in the frequency domain under following conditions:

- limits are in the range extending from 30 Hz to 100 MHz,
- a maximum I_{NB} in units of dB referenced to 1 μ A is a function of frequency defined in Figure A-1,
- in the low frequency range the limit I_{CE} in units of dB referenced to 1 μ A (dB μ A) is function of the consumption I_{dc} (in amperes) of the equipment on the line, see [Figure A-1](#):

$I_{dc} < 1 \text{ A}$	$I_{CE} = 80$
$1 \text{ A} < I_{dc} < 100 \text{ A}$	$I = 80 + 20 \log_{10}(I_{dc})$
$I_{dc} > 100 \text{ A}$	$I = 120$

The mode is called “differential” because measurements are done separately on hot and return wires, however it comprises common mode components.

“Independent” means connected to separate power sources.

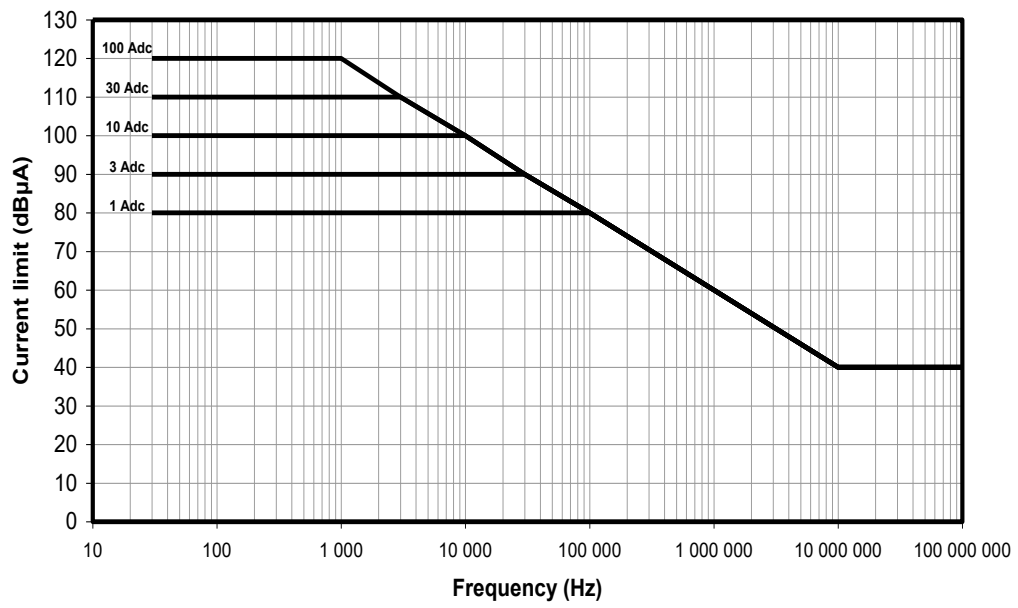

Figure A-1: Power leads, differential mode conducted emission limit

A.3 CE on power leads, in-rush currents

The inrush current of an equipment on the power lines can be limited in the time domain with following characteristics in order to limit the voltage transients on the power bus:

- During any nominal change of configuration, the rate of change of current is limited to 5×10^4 A/s.
- At switching ON the rate of change of current is lower than 2×10^6 A/s, absolute value of rise and fall slopes.
Specific requirements are usually defined for pulsed radars, plasma thrusters power units.

Limits can also be specified for the following characteristics in order to achieve compatibility with the upstream protections of the spacecraft power subsystem.

- inrush current duration (in ms);
- total charge (in mC);
- inrush current slope (in A/ μ s).

Limits to the peak value of the inrush current and to total charge are indirectly specified in the ECSS-E-ST-20-20 for units connected to a LCL/RLCL:

- Sub-clause 5.5.4.1.1 a. of the ECSS-E-ST-20-20 specifies the peak current;
- Sub-clause 5.4.2.3.1 a. of the ECSS-E-ST-20-20 results in specifying the total charge Q not to exceed 80% of the minimum trip-off time multiplied by the minimum current limitation level.

A.4 CE on power and signal leads, common mode, 100 kHz to 100 MHz

The conducted emissions on bundles in common mode can be limited with following characteristics:

- limits are in the range extending from 100 kHz to 100 MHz,
- I_{CE} in units of dB referenced to 1 μ A (dB μ A) is lower than the curve of Figure A-2,
- the same limit is defined for all cables taken together or bundle per bundle.

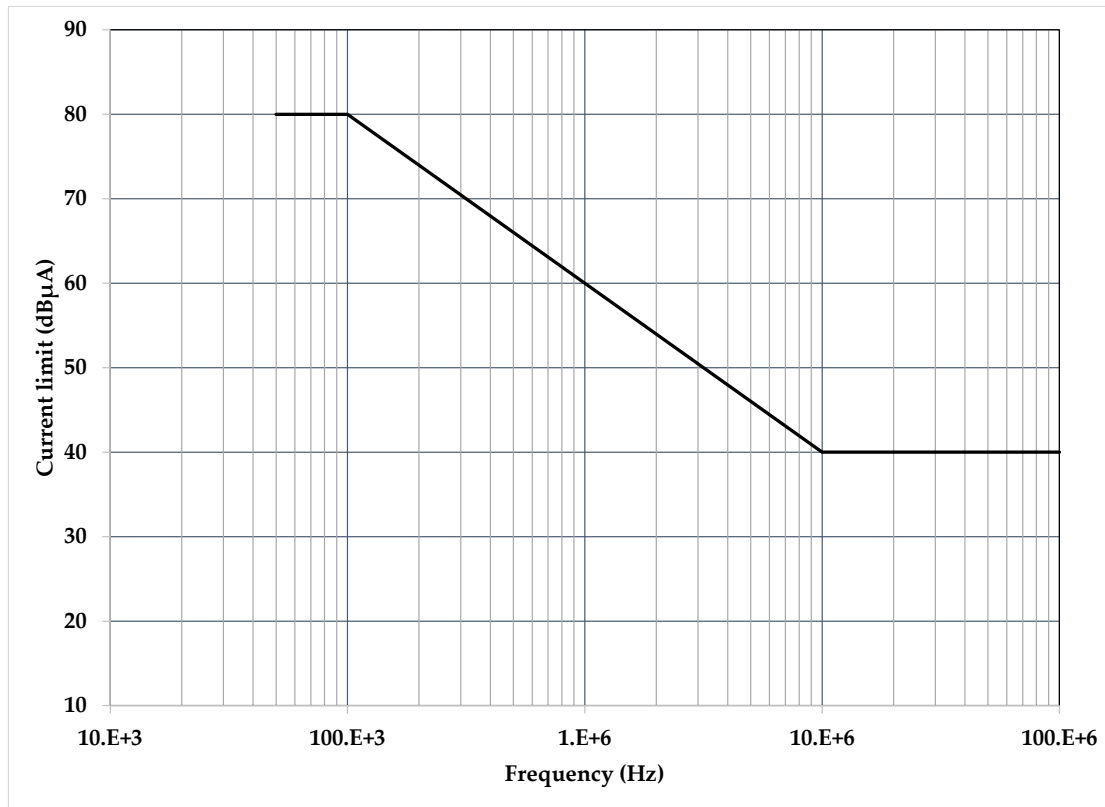

Figure A-2: Common mode conducted emission limit

A.5 <<deleted>>

A.6 DC magnetic field emission

A.6.1 General

The DC magnetic field emission generated by subsystems, equipment and elementary components is limited or characterized for following purposes:

- for establishing the magnetic moment of the whole space vehicle,
- for establishing the composite DC magnetic field at critical locations.

The components of the magnetic emission are DC current loops, solenoids, the permanent field of hard magnetic materials (magnets) and the induced magnetic moment by the Earth-field on soft magnetic materials, including hysteresis.

A.6.2 Characterization

Test distances in the range 0,3 m to 0,7 m can be used.

A.6.3 Limit

For the objective of limiting the magnetic moment of a space segment element and the resulting torque with the Earth magnetic field at the relevant orbit, the DC magnetic emission of subsystems or units can be limited to a level of 0,2 μT at a distance of 1m from any face of the equipment.

This limit corresponds to a dipole-like equipment with a magnetic moment of 1 Am^2 .

A.7 RE, low-frequency magnetic field

From a few hertz to 50 kHz, the magnetic-field radiated emissions can be measured.

Measurement can be performed at several distances for characterizing the accuracy of a dipole model.

If the EUT can be assimilated to a magnetic dipole, emission limits are expressed by its magnetic dipole momentum.

No limit is defined at equipment level.

The measurement is only for characterization and useful to verify compliance at system level through analysis.

Techniques for fulfilling EMC requirement at system level are an appropriate grounding network, magnetic shields, an optimized location of equipments on the space vehicle.

A.8 RE, low-frequency electric field

From a few hertz to 30 MHz frequency range the electric-field radiated emissions of units can be measured.

The frequency limits are determined by the EMCAB from payload specifications.

The electric field emission from the equipment is expressed in units of dB above 1 $\mu\text{V/m}$ at a distance of 1 m.

Measurements at several distances are performed for characterizing the decay law.

No limit is defined at equipment level.

The measurement is only for characterization and useful to verify compliance with system level requirements through analysis.

Techniques for fulfilling EMC requirement at system level are reduction of common mode conducted emission from bundles, and electric shields or appropriate location of equipments on the space vehicle.

A.9 RE, electric field, 30 MHz to 18 GHz

In the 30 MHz to 18 GHz frequency range, electric-field radiated-emissions from equipment and subsystem including interconnecting cables can be limited under following conditions:

- the limit applies to:
 - non-RF equipment,
 - RF equipment connected to passive loads or EGSE, in nominal mode, at nominal power,
- the limit is defined by the curve in [Figure A-3](#),
- the limit is for both horizontally and vertically polarized fields,
- the limit comprises notching lines for launchers or spacecraft receiving bands not represented in [Figure A-3](#).

Additional requirements can apply beyond 18 GHz if SHF or EHF payloads are present. These are beyond the scope of the present standard.

For equipment having all internal rise times longer than 35 ns, the specified upper frequency limit can be reduced to 1 GHz.

For non-RF equipment if the emission is lower than 20 dB below the requirement between 500 MHz and 1 GHz the specified upper limit can be reduced to 1 GHz, with the exception of notches above 1 GHz, still to be tested.

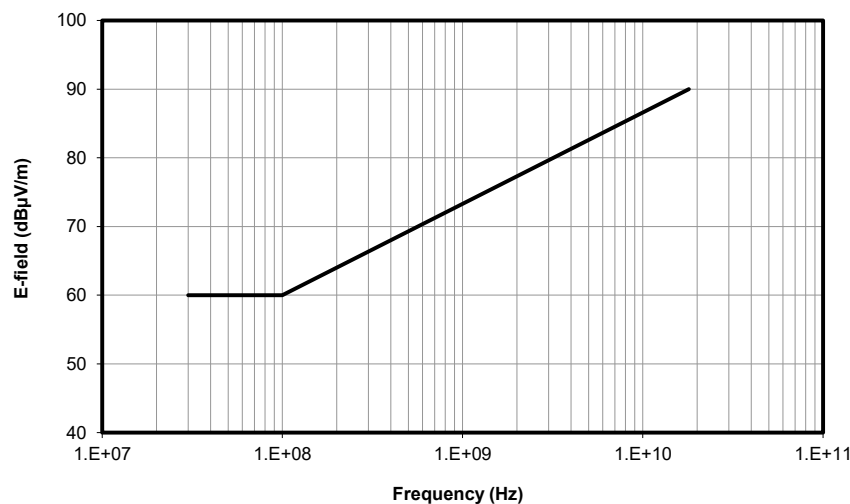

Figure A-3: Radiated electric field limit

A.10 CS, power leads, differential mode, 30 Hz to 100 kHz

The following levels, known to be achievable and already specified in other standards or project specifications, are proposed for the susceptibility test on the power leads specified in clause [5.4.7](#).

- the injected voltage level is equal or larger than the level shown in [Figure A-4](#),
- a limitation of the injected current before the specified voltage is reached is applied:
 - the limit of current is 1 A_{rms}
 - the voltage level when the current limit is reached is measured and reported.

The current applied is reported.

Independent power lines are tested separately.

NOTE Independent means “connected to separate power sources”.

The test signal covers the [30 Hz-100 kHz] frequency range.

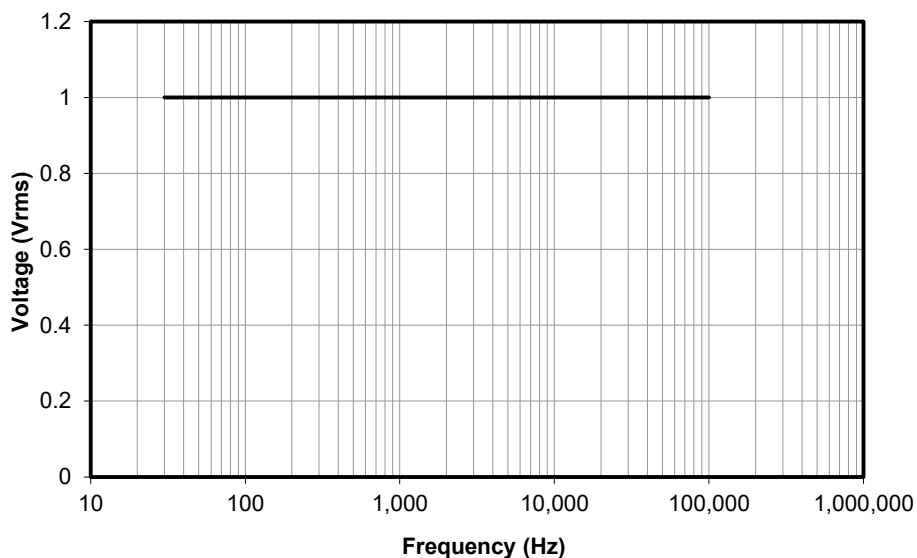

Figure A-4: Conducted susceptibility limit, frequency domain

A.11 CS, power and signal leads, common mode, 50 kHz to 100 MHz

The following levels, known to be achievable and already specified in other standards or project specifications, are proposed for the susceptibility test on the power and signal leads specified in clause [5.4.8](#):

- [the injection probe drive level is pre-calibrated so as to reach the level shown in Figure A-5 at the measurement port of the calibration fixture \(jig\)](#),
- the limit of the current induced in the bundle is [limited to 0,3 A peak-to-peak](#),

NOTE [It is unlikely to be exceeded.](#)

- the test signal is pulse modulated,
NOTE Square wave modulation is a particular case of pulse modulation.
- the duty cycle [according to carrier frequency is selected from Table A-1, and deviates from the default modulation of susceptibility test signals specified in 5.2.10.2.](#)

The same level is applied to all cables together or to bundles taken separately.

The common mode induced current on the bundle is reported.

The test signal covers the [50 kHz-100 MHz] frequency range.

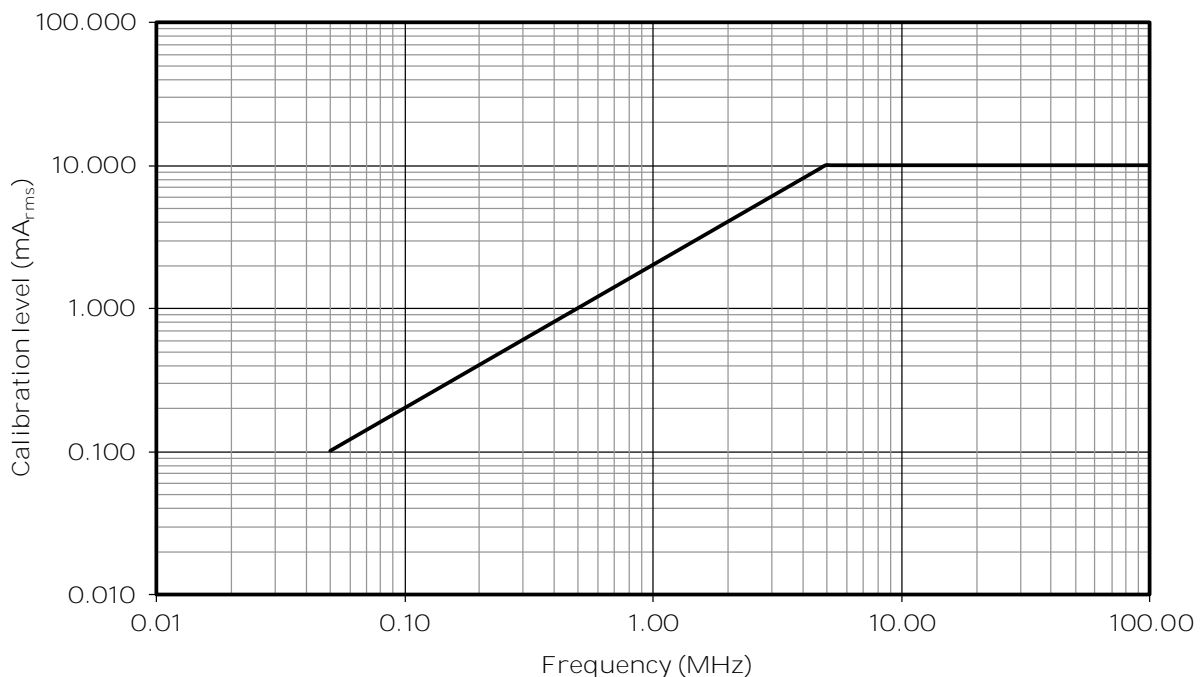

Figure A-5: Calibration level at the measurement port of the calibration fixture

Table A-1: Equipment: susceptibility to conducted interference, test signal

Frequency range	Pulse repetition frequency	Duty cycle
50 kHz-1 MHz	1 kHz	50 % (squarewave)
1 MHz-10 MHz	100 kHz	20 %
10 MHz-100 MHz	100 kHz	5 %

A.12 CS, power leads, short spike transients

The following levels, known to be achievable and already specified in other standards or project specifications, are proposed for the transient susceptibility test on the power lines specified in clause 5.4.9:

- a series of positive spikes, then a series of negative spikes superposed on the power voltage,
- at any time step, the voltage spike amplitude is:
 - +100 % or -100 % of the actual line voltage if the nominal bus voltage is lower than 100 V, Figure A-6.
 - +50 % or -100 % of the actual line voltage if the nominal bus voltage is equal or larger than 100 V

Level 0 in Figure A-6 represents the DC bus voltage.

Only the positive spike is represented in Figure A-6.

When a negative spike is applied, the absolute instantaneous transient voltage goes down to 0, never negative.

- tests are performed with two spike durations, the first zero-crossing is at $T=150$ ns and at $T=10$ μ s.

Independent power lines are tested separately.

Independent means “connected to separate power sources”.

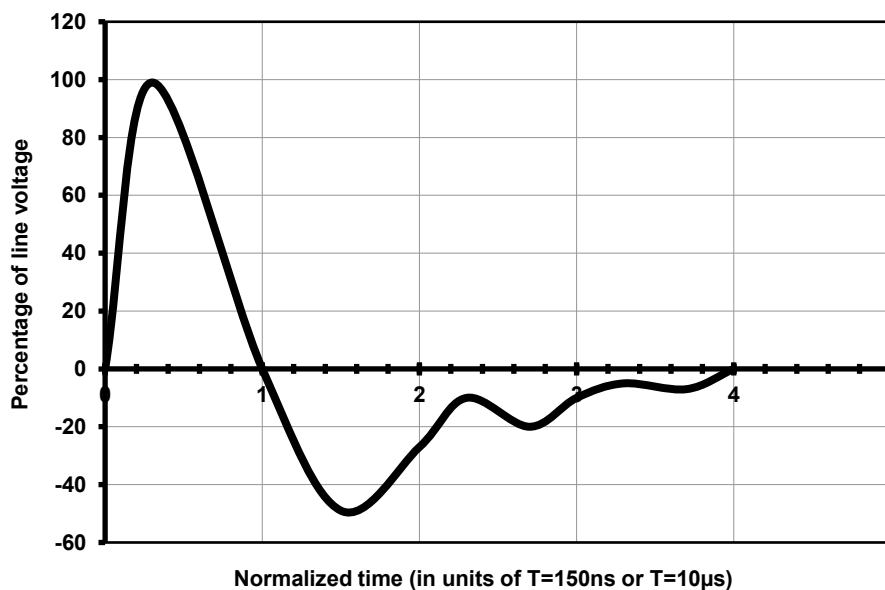

Figure A-6: CS, voltage spike in percentage of test bus voltage

A.13 RS, magnetic field, 30 Hz to 100 kHz

The following levels, known to be achievable and already specified in other standards or project specifications, are proposed for the radiated susceptibility test, magnetic field, specified in clause [5.4.10](#):

- the amplitude of the test signal is equal to or larger than the level in Figure A-7,
- the source is located at 5 cm of any face of the EUT.

The signal test covers the [30 Hz-100 kHz] frequency range.

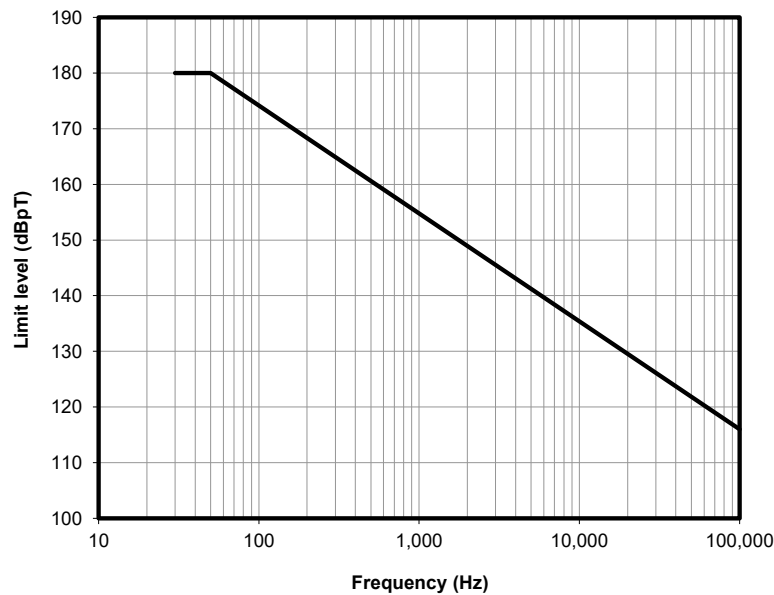

Figure A-7: Radiated susceptibility limit

A.14 RS, electric field, 30 MHz to 18 GHz

The following levels, known to be achievable and already specified in other standards or project specifications, are proposed for radiated susceptibility test, electric field, specified in clause [5.4.11](#):

- the amplitude of the test signal is:
 - equipment in the vicinity of beams, outside of the main frame considered as a Faraday cage: 10 V/m,
 - An electric field of more than 10 V/m is applied if RF analysis demonstrates that the expected electric field seen in flight by the equipment is larger,
 - equipment far from main lobes and secondary lobes, outside of the main frame: 1 V/m,
 - equipment inside the main frame: 1 V/m.

At RF transmit frequencies, the RS level should be tailored up; at RF receive frequencies, the RS level should be tailored down for receivers.

- both horizontally and vertically polarized fields are used,
- circular-polarized fields are not used.

The signal test covers the [30 MHz-18 GHz] frequency range.

Additional requirements can apply beyond 18 GHz if SHF or EHF payloads are present. These are beyond the scope of the present standard.

A.15 Susceptibility to electrostatic discharge

The following dispositions, known to be achievable and already specified in other standards or project specifications, are proposed for the ESD test specified in clause [5.4.12](#).

The test is performed on following equipment, including or not digital circuits:

- units comprising high-voltage power sources,
- units man-handled during normal operation,

This condition applies to manned-flight,

For man-handled equipment, an ESD test by the contact discharge method as defined in IEC-61000-4-2, is more appropriated,

- units outside the main frame of the space vehicle designed as a Faraday cage,
- units connected to sensors, actuators, or other units located outside the main frame designed as a Faraday cage with the exception of the solar array power bus.

Specific tests defined in ECSS-E-ST-33-11 are applied to EEDs.

Test of models expected to be or to become flight models is not performed.

ESD testing can cause latent failures of test article.

Bibliography

- ECSS-S-ST-00 ECSS system – Description, implementation and general requirements
- MIL-STD-461E Requirements for the control of electromagnetic interference, characteristics of subsystems and equipment, 20 August 1999; Department of Defence, USA.