



Space engineering

Electrical and electronic

Foreword

This Standard is one of the series of ECSS Standards intended to be applied together for the management, engineering, product assurance and sustainability in space projects and applications. ECSS is a cooperative effort of the European Space Agency, national space agencies and European industry associations for the purpose of developing and maintaining common standards. Requirements in this Standard are defined in terms of what shall be accomplished, rather than in terms of how to organize and perform the necessary work. This allows existing organizational structures and methods to be applied where they are effective, and for the structures and methods to evolve as necessary without rewriting the standards.

This Standard has been prepared by the ECSS-E-ST-20C Rev.2 Working Group, reviewed by the ECSS Executive Secretariat and approved by the ECSS Technical Authority.

Disclaimer

ECSS does not provide any warranty whatsoever, whether expressed, implied, or statutory, including, but not limited to, any warranty of merchantability or fitness for a particular purpose or any warranty that the contents of the item are error-free. In no respect shall ECSS incur any liability for any damages, including, but not limited to, direct, indirect, special, or consequential damages arising out of, resulting from, or in any way connected to the use of this Standard, whether or not based upon warranty, business agreement, tort, or otherwise; whether or not injury was sustained by persons or property or otherwise; and whether or not loss was sustained from, or arose out of, the results of, the item, or any services that may be provided by ECSS.

Published by: ESA Requirements and Standards [Section](#)
ESTEC, P.O. Box 299,
2200 AG Noordwijk
The Netherlands

Copyright: 2022 © by the European Space Agency for the members of ECSS

Change log

ECSS-E-20A 4 October 1999	First issue
ECSS-E-20B	Never issued
ECSS-E-ST-20C 31 July 2008	Second issue
ECSS-E-ST-20C Rev.1 15 October 2019	Second issue Revision 1
ECSS-E-ST-20C Rev.2 8 April 2022	<p>Second issue Revision 2</p> <p>Changes with respect to ECSS-E-ST-20C (6 March 2009) are the following and identified in the document with revision tracking.</p> <p>Main changes are:</p> <ul style="list-style-type: none"> • Clause 4.2.1.1 added due to addition of new clause 4.2.1.2 • Addition of requirements in new clause 4.2.1.2 “Reliable insulation” • The addition of the new clause 4.2.1.2 made it necessary to add the new header 4.2.1.1 “General requirements” to separate the requirement from the former clause 4.2.1 “Failure containment and redundancy” from the new requirements for “Reliable insulation”. • Update to cover the aspects of “reliable insulation” also known as “double insulation” • Addition of several terms in clause 3.2 related to the added subject of “Reliable insulation” <p>Detailed changes</p> <p><u>Added requirements:</u></p> <ul style="list-style-type: none"> • 4.2.1.1y; 4.2.1.2.2a; 4.2.1.2.3a-cc; Table 4-1; 5.5.2r-u. <p><u>Modified requirements:</u></p> <ul style="list-style-type: none"> • 4.2.2.1j; 4.2.2.2e; 5.5.2e-g; 5.5.2i and p Note; Table 5-2 Note; 5.6.2j and o; A.2.1d. <p><u>Deleted requirements:</u></p> <ul style="list-style-type: none"> • 5.8.1c.

Table of contents

Change log	3
1 Scope	8
2 Normative references	9
3 Terms, definitions and abbreviated terms	10
3.1 Terms from other standards	10
3.2 Terms specific to the present standard	10
3.3 Abbreviated terms	17
3.4 Nomenclature	19
4 General requirements	20
4.1 Interface requirements.....	20
4.1.1 Overview	20
4.1.2 Signals interfaces	20
4.1.3 Commands	21
4.1.4 Telemetry	22
4.2 Design.....	23
4.2.1 Failure containment and redundancy	23
4.2.2 Data processing.....	34
4.2.3 Electrical connectors.....	36
4.2.4 Testing.....	38
4.2.5 Mechanical: Wired electrical connections	39
4.2.6 Miscellaneous	39
4.3 Verification	40
4.3.1 Provisions	40
4.3.2 Documentation	41
5 Electrical power	42
5.1 Functional description	42
5.2 Power subsystem and budgets.....	42
5.2.1 General.....	42
5.2.2 Provisions	42
5.3 Failure containment and redundancy.....	44
5.4 Electrical power interfaces.....	45
5.5 Power generation	46

5.5.1	Solar cell, coverglass, SCA and PVA qualification	46
5.5.2	Solar array specification and design	46
5.5.3	Solar array power computation	49
5.5.4	Solar array drive mechanisms.....	52
5.6	Electrochemical Energy Storage	52
5.6.1	Applicability.....	52
5.6.2	Batteries	52
5.6.3	Battery cell.....	55
5.6.4	Battery use and storage.....	56
5.6.5	Battery safety.....	56
5.7	Power conditioning and control.....	58
5.7.1	Applicability.....	58
5.7.2	Spacecraft bus.....	58
5.7.3	Battery Charge and Discharge Management	62
5.7.4	Bus under-voltage or over-voltage	64
5.7.5	Power converters and regulators	65
5.7.6	Payload interaction	66
5.8	Power distribution and protection	67
5.8.1	General.....	67
5.8.2	Harness	71
5.9	Safety.....	73
5.10	High voltage engineering.....	73
5.11	Verification	73
5.11.1	Provisions.....	73
5.11.2	<<deleted>>	74
6	Electromagnetic compatibility (EMC)	75
6.1	Overview	75
6.2	Policy	75
6.2.1	Overall EMC programme	75
6.2.2	EMC control plan	75
6.2.3	Electromagnetic compatibility advisory board (EMCAB).....	76
6.3	System level.....	77
6.3.1	Electromagnetic interference safety margin (EMISM)	77
6.3.2	Inter-element EMC and EMC with environment	78
6.3.3	Hazards of electromagnetic radiation.....	78
6.3.4	Spacecraft charging protection program	79
6.3.5	Intrasystem EMC	80

6.3.6	Radio frequency compatibility	80
6.3.7	Spacecraft DC magnetic field emission.....	81
6.3.8	Design provisions for EMC control	81
6.3.9	Detailed design requirements	82
6.4	Verification	82
6.4.1	Verification plan and report	82
6.4.2	Safety margin demonstration for critical or EED circuit	82
6.4.3	Detailed verification requirements.....	83
7	Radio frequency systems	84
7.1	Functional description	84
7.2	Antennas.....	85
7.2.1	General.....	85
7.2.2	Antenna structure	86
7.2.3	Antenna interfaces.....	93
7.2.4	Antennas Verification.....	94
7.3	RF Power	95
7.3.1	Overview	95
7.3.2	RF Power handling (thermal).....	95
7.3.3	Corona or Gas Discharge	96
7.3.4	Qualification for power handling and gas discharge.....	96
7.4	Passive intermodulation	97
7.4.1	Overview	97
7.4.2	General requirements	97
7.4.3	Identification of potentially critical intermodulation products.....	97
7.4.4	Verification.....	98
7.4.5	Qualification for passive intermodulation.....	98
7.5	Verification	98
8	Pre-tailoring matrix per space product and feature types	99
8.1	Introduction	99
8.2	Use of the inclusive and exclusive requirement categories.....	100
	Annex A (normative) EMC control plan - DRD	165
	Annex B (normative) Electromagnetic effects verification plan (EMEVP) - DRD	168
	Annex C (normative) Electromagnetic effects verification report (EMEVR) - DRD	171

Annex D (normative) Battery user manual - DRD	173
--	------------

Bibliography	174
---------------------------	------------

Figures

Figure 5-1: Output impedance mask (Ohm)	61
---	----

Figure 5-2: Source and load impedance characterisation.....	69
---	----

Figure 5-3: Thevenin equivalent model	69
---	----

Figure 5-4: Norton equivalent model	70
---	----

Tables

Table 4-1: List of rigid and non-rigid materials.....	31
---	----

Table 5-1: Parameters for BOL worst and best case power calculations.....	51
---	----

Table 5-2: Additional power parameters for EOL worst and best case calculations....	51
---	----

Table 5-3: <<deleted, merged with new Table 8-3>>	74
---	----

Table 7-1: <<deleted, merged with new Table 8-3>>	94
---	----

Table 7-2: <<deleted, merged with new Table 8-3>>	98
---	----

Table 8-1: Definition of pre-tailoring matrix applicability statuses	102
--	-----

Table 8-2: Definition of features for exclusive requirements	102
--	-----

Table 8-3: Pre-tailoring matrix per "Space product and feature types".....	103
--	-----

1 Scope

This Standard establishes the basic rules and general principles applicable to the electrical, electronic, electromagnetic, microwave and engineering processes. It specifies the tasks of these engineering processes and the basic performance and design requirements in each discipline.

It defines the terminology for the activities within these areas.

It defines the specific requirements for electrical subsystems and payloads, deriving from the system engineering requirements laid out in ECSS-E-ST-10 “Space engineering – System engineering general requirements”.

This standard may be tailored for the specific characteristic and constrains of a space project in conformance with ECSS-S-ST-00.

2

Normative references

The following normative documents contain provisions which, through reference in this text, constitute provisions of this ECSS Standard. For dated references, subsequent amendments to, or revision of any of these publications do not apply. However, parties to agreements based on this ECSS Standard are encouraged to investigate the possibility of applying the more recent editions of the normative documents indicated below. For undated references, the latest edition of the publication referred to applies.

ECSS-S-ST-00-01	ECSS system – Glossary of terms
ECSS-E-ST-10	Space engineering – System engineering general requirements
ECSS-E-ST-20-06	Space engineering – Spacecraft charging
ECSS-E-ST-20-07	Space engineering – Electromagnetic compatibility
ECSS-E-ST-20-08	Space engineering - Photovoltaic assemblies and components
ECSS-E-ST-20-20	Space engineering - Electrical design and interface requirements for power supply
ECSS-E-ST-33-11	Space engineering – Explosive systems and devices
ECSS-E-ST-50-05	Space engineering – Radio frequency and modulation
ECSS-E-ST-50-14	Space engineering – Spacecraft discrete interfaces
ECSS-Q-ST-30-02	Space product assurance – Failure modes, effects (and criticality) analysis (FMEA/FMECA)
ECSS-Q-ST-30-11	Space product assurance – Derating – EEE components
ECSS-Q-ST-40	Space product assurance – Safety
ECSS-Q-ST-70-12	Space product assurance – Design rules for printed circuit boards
IEEE 145-1993	Antenna terms
Impedance Specifications for Stable DC Distributed Power Systems, EEE transactions on power electronics, Vol. 17, no. 2, March 2002	Impedance Specifications for Stable DC Distributed Power Systems, X. Feng, J. Liu, F.C. Lee, IEEE Transactions on power electronics, Vol. 17, no. 2, March 2002

Terms, definitions and abbreviated terms

3.1 Terms from other standards

- a. For the purpose of this Standard, the terms and definitions from ECSS-S-ST-00-01 apply.
- b. For the purpose of this Standard, the following terms and definitions from ECSS-E-ST-20-20 apply:
 1. latching current limiter (LCL)
 2. retriggerable latching current limiter (RLCL)

3.2 Terms specific to the present standard

3.2.1 antenna farm

ensemble of all antennas accommodated on the spacecraft and provides for all the transmission and reception of RF signals

3.2.2 antenna port

abstraction of the physical connection among the antenna and its feeding lines, realised by means of connectors or waveguide flanges

3.2.3 antenna RF chain

sequence of microwave components inserted between an antenna input port or a BFN output port and a corresponding individual radiating element

NOTE Examples of microwave components are: ortho-mode transducers, polarisers, transformers as well as filters.

3.2.4 antenna support structure

part of an antenna having no electrical function, which can however impact its electrical performances, either directly due to scattering or indirectly

NOTE Example of indirect effect is induced thermo-elastic deformations.

3.2.5 array antenna

antenna composed by a number of, possibly different, elements that radiate RF signals directly into free space operating in combination, such that all or a part of them radiate the same signals

3.2.6 array-fed reflector antenna

antenna composed by a feed array, which can include or not a beam forming network, and one or more optical elements like reflectors and lenses

3.2.7 battery bus

primary power bus directly connected to the battery

NOTE Battery bus is sometimes called unregulated bus (although the battery charge is regulated).

3.2.8 beam forming network (BFN)

wave-guiding structure composed a chain of microwave components and devices aimed at distributing the RF power injected at the input ports to a number of output ports; in a transmitting antenna the RF power injected from the transmitter is routed to the radiating elements, in a receiving antenna the RF power coming from the radiating elements is routed to the antenna ports connected to the receiver

NOTE Examples of microwave components and devices are lines, phase shifters, couplers, loads.

3.2.9 conducted emission (CE)

desired or undesired electromagnetic energy that is propagated along a conductor

3.2.10 critical line

[CONTEXT: reliable insulation] line that is part of a critical net

NOTE As an example, limited to a solar array, typically a critical line is a line that carries the current of a section downstream from the electrical node collecting the current from the different strings that constitute the section. However, in case a short between strings within a section leads to a failure propagation, then correspondingly a string is considered as a critical line.

3.2.11 critical net

[CONTEXT: reliable insulation] electrical net that if short circuited with another electrical net or another conductor including satellite and launcher structure can cause critical effects

NOTE For “critical effects” see Table 4-1 of ECSS-Q-ST-30-02.

3.2.12 critical pressure

pressure at which corona or partial discharge can occur in an equipment

3.2.13 diffusivity

ability of a body to generate incoherent diffuse scattering due to local roughness, inhomogeneity or anisotropy when illuminated by RF waves

3.2.14 depth of discharge (DOD)

ampere-hour removed from a battery expressed as a percentage of the nameplate capacity

3.2.15 double insulation

see “reliable insulation”

3.2.16 electrical bonding

process of connecting conductive parts to each other so that a low impedance path is established for grounding and shielding purposes

3.2.17 electromagnetic compatibility (EMC)

ability of equipment or an element to function satisfactorily in its electromagnetic environment without introducing intolerable electromagnetic disturbances to anything in that environment

3.2.18 electromagnetic compatibility control

set of techniques to effectively regulate the electromagnetic interference environment or susceptibility of individual space system components or both

NOTE They include, among others, the design, placement of components, shielding, and employment of rejection filters.

3.2.19 electromagnetic interference (EMI)

undesired electrical phenomenon that is created by, or adversely affects any device whose normal functioning is predicated upon the utilization of electrical phenomena

NOTE It is characterized by the manifestation of degradation of the performance of an equipment, transmission channel, or element caused by an electromagnetic disturbance.

3.2.20 electromagnetic interference safety margin (EMISM)

ratio between the susceptibility threshold and the interference present on a test point

3.2.21 emission

electromagnetic energy propagated by radiation or conduction

3.2.22 energy balance

situation in which the spacecraft energy budget is positive when elaborated over a considered period of time

NOTE 1 Energy budget is generation minus consumption and losses.

NOTE 2 The considered period of time can be one orbit, several orbits or any relevant mission period.

3.2.23 energy reserve

energy that remains available from the energy storage assembly at the worst-case, most depleted, point of nominal operations

NOTE It is important that the energy reserve is sufficient to permit reaching a safe operating mode upon occurrence of an anomaly

3.2.24 essential function

function without which the spacecraft cannot be recovered following any conceivable on-board or ground-based failure

NOTE Examples of unrecoverable spacecraft is when spacecraft cannot be commanded, or permanently losses attitude and control, or the energy balance is no longer ensured, or the spacecraft consumables (e.g. hydrazine or Xenon) are depleted to such an extent that more than 10% of its lifetime is affected, or the safety of the crew is threatened.

3.2.25 faulty signal

signal generated by a circuit, appearing at its interface to another circuit, going out of its nominal range because of a failure

3.2.26 foldback current limiter (FCL)

non latching current-limiting function where the current limit decreases with the output voltage

NOTE This function is used for power distribution and protection typically for essential loads.

3.2.27 fully regulated bus

bus providing power during sunlight and eclipse periods with a regulated voltage

3.2.28 grounding

process of establishing intentional electrical conductive paths between an electrical circuit reference or a conductive part and equipment chassis or space vehicle structure

NOTE grounding is typically performed for safety, functionality, signal integrity, EMI control or charge bleeding purpose.

3.2.29 high Priority telecommand (HPC)

command originated from ground and issued by the telecommand decoder for essential spacecraft functions without main on board software intervention

3.2.30 high voltage

AC or DC voltage at which partial discharges, corona, arcing or high electrical fields can occur

3.2.31 insulation

separation of elements either by material or by a distance

NOTE Etymologically, insulation is the act of protecting something with a material that prevents heat, sound, electricity, etc. from passing through. To insulate will then correspond to the action to protect by adding a material, an insulation (materials or device used for this protection).

3.2.32 invariable gap

physical distance among electrically conductive elements respecting the specified minimum limits independent from the stresses applied to the unit or part of the unit

NOTE 1 Changes of the gap can result from effects of mechanical, thermomechanical or other nature, applied to the unit or part of the unit.

NOTE 2 Stresses include the impacts of AIT operations, environmental tests, ageing and the use of insulation materials.

3.2.33 isolation

separation of elements put far from each other, with the notion of distance

NOTE To isolate is the action to separate by adding distance and to be isolated means protected by a distance.

3.2.34 lens antenna

antenna composed by a number of RF lenses and reflecting surfaces illuminated by a primary source, the feed

3.2.35 lightning indirect effects

electrical transients induced by lightning in electrical circuits due to coupling of electromagnetic fields

3.2.36 major reconfiguration function

function used to recover from system failures of criticality 1, 2 or 3

NOTE Criticality categories are defined in ECSS-Q-ST-30 and ECSS-Q-ST-40.

3.2.37 nameplate capacity

capacity stated by the manufacturer of an energy storage cell or battery

NOTE It is given in ampere-hours. It is not necessarily equal to any measurable capacity.

3.2.38 non essential loads

loads related to units which do not implement essential functions for the spacecraft

3.2.39 passive intermodulation products (PIM)

spurious signals generated by non-linear current-voltage characteristics in materials and junctions exposed to sufficiently RF high power carried by guided or radiated fields and currents, possibly triggered by microscopic mechanical movement

3.2.40 photovoltaic assembly (PVA)

power generating network comprising the interconnected solar cell assemblies, the shunt and blocking diodes, the busbars and wiring collection panels, the string, section and panel wiring, the wing transfer harness, connectors, bleed resistors and thermistors

3.2.41 primary cell or battery

battery or cell that is designed to be discharged once and never to be recharged

3.2.42 primary power bus

spacecraft electrical node closest to the power sources where power is controlled and made available to the user equipment

3.2.43 radiofrequency (RF)

frequency band used for electromagnetic waves transmission

3.2.44 radiated emission (RE)

radiation and induction field components in space

3.2.45 recharge ratio (k)

ampere-hours charged divided by the ampere-hours previously discharged, starting and finishing at the same state of charge

NOTE It is also known as the k factor.

3.2.46 reflector antenna

antenna composed by a number of reflecting surfaces, RF reflectors, illuminated by a primary source, the feed

3.2.47 reliable insulation

barrier between conductors or elements of an electrical circuit such that after any credible single failure, conductors or elements of an electrical circuit are still insulated from each other

NOTE The term “**reliable insulation**” is preferred to the term “**double insulation**” that was used in the previous version.

3.2.48 RF chain

sequence of microwave components inserted between the RF power amplifier and the antenna input port

3.2.49 RF lens

plastic, composite or metallic structure acting on transmitted RF waves to control the antenna pattern

NOTE Example of metallic structures are waveguide array lenses.

3.2.50 RF reflector

metallic or composite structure, possibly metallised or with printed or embedded metallic elements, acting on reflected RF waves to control the antenna pattern

NOTE Frequency and polarisation surfaces as well as other fully reflecting or partially reflecting and transmitting structures, also having non-uniform or anisotropic scattering behaviour, are considered reflectors

3.2.51 secondary cell or battery

battery or cell that is designed to be charged and discharged multiple times.

3.2.52 solar aspect angle (SAA)

angle between the normal to a solar panel and the sun vector

3.2.53 solar cell assembly (SCA)

solar cell together with interconnector, coverglass and if used, also a by-pass diode

3.2.54 susceptibility

malfunction, degradation of performance, or deviation from specified indications, beyond the tolerances indicated in the individual equipment or subsystem specification in response to other than intended stimuli

3.2.55 susceptibility threshold

interference level at a test point which just causes malfunction in the equipment, subsystem, or system

3.2.56 vacuum

environment with a pressure of 10 Pa or below

3.2.57 variable gap

physical distance among electrically conductive elements that can be subject to changes due to different effects

NOTE 1 Changes of the gap can result from effects of mechanical, thermomechanical or other nature, applied to the unit or part of the unit.

NOTE 2 Changes include the impacts of AIT operations, environmental tests, ageing and the use of insulation materials.

3.3 Abbreviated terms

For the purpose of this Standard, the abbreviated terms from ECSS-S-ST-00-01 and the following apply:

Abbreviation	Meaning
A	Analysis
AC	alternating current
AR	acceptance review
BOL	beginning-of-life
CDR	critical design review
DC	direct current
DDF	design definition file
DJF	design justification file
DOD	depth of discharge
DRB	Delivery review board
DRD	document requirement definition
DRL	document requirement list
EED	electro-explosive device
EGSE	electrical ground support equipment
EIDP	end item data-package
EMC	electromagnetic compatibility
EMCAB	EMC Advisory Board
EMEVP	electromagnetic effects verification plan
EMEVR	electromagnetic effects verification report
EMI	electromagnetic interference
EOL	end of life
EPS	electrical power subsystem
ESA	European space agency
ESD	electrostatic discharge

Abbreviation	Meaning
FCL	fold-back current limiter
FDIR	failure detection isolation and recovery
FMECA	failure mode effect and criticality analysis
INS	Inspection
ICD	interface control document
I-V	current-voltage
LCL	latching current limiter
MPPT	maximum power point tracker
MRB	manufacturing review board
OBC	on-board computer
PCB	printed circuit board
PDR	preliminary design review
PVA	photovoltaic assembly
QTR	qualification test report
RF	radio frequency
RLCL	retriggerable latching current limiter
ROD	review of design
PSA	Part stress analysis
SAA	solar aspect angle
SADM	solar array drive mechanism
SCA	solar cells assembly
SEE	single event effects
SEU	single event upsets
SPF	single point failure
SRR	system requirement review
T	test
TRB	test review board
TRR	test readiness review
TM&TC	telemetry/telecommand
UV	ultraviolet
VCD	verification control document
WCA	worst case analysis

3.4 Nomenclature

The following nomenclature applies throughout this document:

- a. The word “shall” is used in this Standard to express requirements. All the requirements are expressed with the word “shall”.
- b. The word “should” is used in this Standard to express recommendations. All the recommendations are expressed with the word “should”.

NOTE It is expected that, during tailoring, recommendations in this document are either converted into requirements or tailored out.

- c. The words “may” and “need not” are used in this Standard to express positive and negative permissions, respectively. All the positive permissions are expressed with the word “may”. All the negative permissions are expressed with the words “need not”.
- d. The word “can” is used in this Standard to express capabilities or possibilities, and therefore, if not accompanied by one of the previous words, it implies descriptive text.

NOTE In ECSS “may” and “can” have completely different meanings: “may” is normative (permission), and “can” is descriptive.

- e. The present and past tenses are used in this Standard to express statements of fact, and therefore they imply descriptive text.

General requirements

4.1 Interface requirements

4.1.1 Overview

ECSS-E-ST-10 specifies that interfaces external or internal to a system are adequately specified and verified. The following requirements address this issue and are processed in phase B, C and D of a project (see ECSS-E-ST-10).

4.1.2 Signals interfaces

ECSS-E-ST-20_0020001

- a. Interface engineering shall ensure that the characteristics on both sides of each interface are compatible, including source and load impedances, the effects of the interconnecting harness and the grounding network between both sides comprising: common mode impedance conducted and radiated susceptibility and emission.

ECSS-E-ST-20_0020002

- b. In order to minimize the number of interface types, standard interface circuitry shall be defined to be applied throughout a project.

ECSS-E-ST-20_0020003

- c. Reconfiguration, high level or high priority command lines shall be immune to spurious activation.

ECSS-E-ST-20_0020004

- d. The application of the nominal signals or a faulty signal to an un-powered interface shall not cause damage to that interface.

NOTE This requirement covers all types of interfaces.
Standard interfaces are covered in clauses 4.2.4.3 and 4.2.4.4 of ECSS-E-ST-50-14.

ECSS-E-ST-20_0020005

- e. An undetermined status at the interfaces of a powered unit shall not cause damage to an un-powered interface.

NOTE Undetermined status includes: non-nominal operating modes, permanent and non-permanent failure modes, powered and un-powered interfaces.

ECSS-E-ST-20_0020006

- f. Signal interfaces shall withstand without damage positive or negative nominal voltages that are accessible on the same connector, coming from the unit itself, from the interfaced units or from EGSE.

4.1.3 Commands

ECSS-E-ST-20_0020007

- a. Every command (intended to be sent to the spacecraft) shall be assessed for criticality at equipment level, and confirmed at subsystem/system level.

NOTE The criticality of a command is measured as its impact on the mission in case of inadvertent function (erroneous transmission), incorrect function (aborted transmission) or loss of function. The definition of criticalities can be found in ECSS-Q-ST-30 and ECSS-Q-ST-40.

ECSS-E-ST-20_0020008

- b. All executable commands shall be explicitly acknowledged by telemetry.

ECSS-E-ST-20_0020009

- c. High Priority telecommand decoding and generation shall be independent from the main on-board processor and its software.

NOTE For failure case, refer to requirement 4.2.1.1a.

ECSS-E-ST-20_0020010

- d. With the exception of pyrotechnic commands, the function of an executable command shall
 1. not change throughout a mission, and
 2. not depend on the history of previous commands.

ECSS-E-ST-20_0020011

- e. For commands of category 1 and 2 criticality, at least two separate commands for execution: an arm/safe or enable/disable followed by an execute command shall be used.

NOTE For criticality categories, see ECSS-Q-ST-30 or ECSS-Q-ST-40.

ECSS-E-ST-20_0020012

- f. The functionality shall be provided to repeat the transmission of all the executable commands without degradation of the function or a change of its status.

ECSS-E-ST-20_0020013

- g. In case of critical commands of category 1 and 2, at least two physically independent electrical barriers, including associated control circuits, shall be implemented for arming and executing the command.

NOTE 1 For criticality categories, see ECSS-Q-ST-30 or ECSS-Q-ST-40.

NOTE 2 Mechanical barriers can be considered.

NOTE 3 Physically independent electrical barriers and associated control circuits are the ones not sharing any hardware function and without risk of reciprocal failure propagation.

ECSS-E-ST-20_0020014

- h. Processor and simple logic circuits shall not be able to issue category 1 and 2 critical commands without a ground commanded arm/safe or enable/disable command.

NOTE To avoid inadvertent activation of processes enabled/disabled by category 1 or 2 critical commands during ground operations and in low earth orbit phases, it is necessary to foresee safety barriers (arm/safe commands) to inhibit the execution of such critical commands. Such safety barriers might be spacecraft skin connections (to be established or broken just before flight) or connections/disconnection plugs to be activated by launcher stages release (in flight). The activation/deactivation of such barriers has to be independent from on board processor.

ECSS-E-ST-20_0020015

- i. Any on-board processing which issues commands to reconfigure subsystems or payloads shall be overridable and potentially inhibited by ground command.

NOTE For criticality categories, see ECSS-Q-ST-30 or ECSS-Q-ST-40.

ECSS-E-ST-20_0020016

- j. No valid command shall be issued until the transmitter power supply is within operational voltage range and ready to transmit the command.

4.1.4 Telemetry

ECSS-E-ST-20_0020017

- a. Telemetry data devoted to the spacecraft subsystem and payloads monitoring shall allow

1. the retracing of the overall configuration at least up to all reconfigurable elements.
2. the location of any failure able to impact the mission performances and reliability at least up to all reconfigurable elements.

ECSS-E-ST-20_0020386

- b. The operational status (On/Off, enabled/disabled, active/not-active) of each element of any telemetry acquisition chain should be provided to the on-board computer in order to determine without ambiguity the validity of the telemetry data at the end of the overall chain.

ECSS-E-ST-20_0020019

- c. Primary bus load currents shall be monitored by telemetry, to enable, together with the bus voltage telemetry, a complete monitoring of a primary bus power load.

ECSS-E-ST-20_0020020

- d. Telemetry shall be implemented to monitor the evolution of the power-energy resources and the source temperatures during the mission.

4.2 Design

4.2.1 Failure containment and redundancy

4.2.1.1 General requirements

ECSS-E-ST-20_0020021

- a. Failure propagation shall meet the following conditions:
 1. A single hardware failure does not propagate to neighbouring components circuits or interfaces in an undetermined way.
 2. Failure propagation is verified by analysis.
 3. Mechanical, thermal or electrical propagation of single hardware failures does not impair the corresponding protection or redundancy implemented at equipment or system level.
 4. Single hardware failure does not propagate to equipment or functions under different contractual responsibility than the item where the failure takes place.

NOTE 1 4.2.1.1a.4 is normally covered by specification of fault emission and tolerance conditions.

NOTE 2 Component assembly (e.g. single cavity hybrid) and integrated circuits, especially if they contain redundancy or protection, require special attention."

ECSS-E-ST-20_0020022

- b. Redundant signal or power lines should be segregated via physically separated connectors and harnesses.

ECSS-E-ST-20_0020387

- c. Routing of redundant power or signal lines within common harness or connector shall be justified by analysis showing that inside the electrical unit and at external connector interface level there is no potential single failure leading to affect both nominal and redundant lines or to generate electrical or electromagnetic interference between both.

NOTE 1 Typical analysis for demonstrating compliance is provided within FMEA and EMC coupling analysis.

NOTE 2 Potential single failure includes short-circuit cases.”

ECSS-E-ST-20_0020024

- d. Redundant functions shall be physically separated with no risk of failure propagation by thermal or other coupling and as a minimum, contained within different integrated circuits to avoid failure propagation.

ECSS-E-ST-20_0020025

- e. For redundant functions implemented on the same PCB, a physical separation shall be provided, with no risk of thermal or other failure propagation.

NOTE Example of physical separation are by a minimum distance, insulation, or cut-out.

ECSS-E-ST-20_0020026

- f. For redundant functions implemented on the same PCB, any deviation of the physical separation specified in 4.2.1.1e shall be tracked in the Critical item List.

ECSS-E-ST-20_0020027

- g. <<deleted>>

ECSS-E-ST-20_0020028

- h. In case a cold redundant function is simultaneously activated together with the nominal one, by a deliberate or wrong command or due to a fault, this shall not induce permanent degradation of either of the two functions or loss of the mission before FDIR action.

NOTE E.g. thermal and EMC functions.

ECSS-E-ST-20_0020029

- i. <<deleted>>

ECSS-E-ST-20_0020030

- j. Any active equipment, excluding heaters, **continuously** dissipating more than 20 W in nominal or failure condition shall include a temperature monitoring function, which is implemented and provides continuous temperature monitoring.

ECSS-E-ST-20_0020031

- k. In case of signal cross-strapping, no single failure of either interface circuit shall propagate to the other one.

ECSS-E-ST-20_0020032

- l. In the case of hot redundant essential functions, latching protection shall not be used unless it has an autonomous periodic reset.

ECSS-E-ST-20_0020033

- m. Disabling critical on-board autonomous functions shall be allowed only if an interlock mechanism is implemented, which prevents the disabling of both main and redundant functions at the same time.

NOTE Critical functions refers to functions which prevent the satellite from being recovered when both main and redundant are switched off, e.g. RF receiver or command decoder.

ECSS-E-ST-20_0020034

- n. Any protection latch, which does not have autonomous reset capability, shall be at least re-settable from ground command.

ECSS-E-ST-20_0020035

- o. Any protection of an essential function shall not share with the essential function itself the same component or integrated circuit nor utilize common references or auxiliary supply.

ECSS-E-ST-20_0020036

- p. Essential functions shall not be lost upon a single failure of other functions which are centrally powered or controlled.

NOTE 1 E.g. on synchronization and auxiliary supply.

NOTE 2 That can imply the capability of an equipment performing an essential function of operating independently of any external synchronization and auxiliary power supply if these are not SPF free.

ECSS-E-ST-20_0020037

- q. For essential functions supplied by an FCL, lock-up phenomenon requiring recovery via the removal of external power shall be prevented.

ECSS-E-ST-20_0020038

- r. All units to be powered during launch shall be designed for operation with critical pressure.

ECSS-E-ST-20_0020039

- s. A venting analysis shall be performed for all units not designed to operate under critical pressure and not powered during launch, to determine when they can safely be turned-on.

ECSS-E-ST-20_0020040

- t. Any on-board autonomous function, the failure of which can result in malfunctions of category 1 and 2 criticality, shall have override capability.

NOTE Examples of override are:

- a simple inhibition or isolation (e.g. cold or hot redundant chain[s] exists)
- an H/W reset (e.g. in case of SEU)
- an inhibition + by-pass (e.g. a stepper motor control loop by-passed by a direct step by step command as back-up)

ECSS-E-ST-20_0020041

- u. Any on-board autonomous protection override, leading to hazardous situation for the mission (category 1 and 2 criticality), shall not be implemented.

NOTE E.g. an LCL function for instance protecting the main power Bus against a short circuit at Bus user level or Main Bus over-voltage protection.

ECSS-E-ST-20_0020042

- v. SEE shall not activate protection circuits of essential functions.

NOTE Mitigation techniques can be implemented to avoid such phenomena: filtering, majority voting, etc

ECSS-E-ST-20_0020043

- w. The spacecraft electrical system shall be single failure tolerant for unmanned mission and double failure tolerant for manned mission.

ECSS-E-ST-20_0020407

- x. Occurrence of a non-destructive SEE after a failure shall not lead to the loss of the mission.

NOTE Accordingly, a non-destructive SEE cannot derail a reconfiguration process after first hardware failure.

ECSS-E-ST-20_0020426

- y. For electrical connections of critical lines directly exposed to free space, the distance between power lines or between power and return lines shall not be considered an effective insulation from dielectric point of view, including inside connectors.

4.2.1.2 Reliable insulation

4.2.1.2.1 Reliable insulation assumptions

“Reliable insulation” was previously called “Double insulation”.

Reliable Insulation requirements present in this standard:

- are intended to avoid short circuit of critical lines or nets due to foreign conductive particles;
- are intended to reduce to negligible the risks of short circuit of critical nets or lines due to errors or marginality in design, manufacturing or integration;
- do not cover short circuits that might be caused by meteorites hitting a spacecraft;
- do not intend to prevent insulation losses inside EEE components. The effects of components internal short-circuit risk is managed through FMECA and mitigated by design. Nevertheless, when an internal short-circuit risk between the chip or the leads and the component case (if metallic) is possible, external insulation or other mitigation actions are required.

NOTE 1 For EEE components different ECSS standards are applicable

NOTE 2 Wires/cables are an exception to this assumption. For them all layers of insulation, including those between wire cores and the respective wire/cable shield, are subject to reliable insulation.

For EEE components (like opto, relay, hybrid, MOS-FET) their internal construction is key to demonstrate compliance to reliable insulation requirements.

Additionally for solar arrays, reliable insulation requirements present in this standard:

- are intended to avoid short circuit of critical lines or nets due to foreign conductive particles, or to plasma or ESD effects.

4.2.1.2.2 Reliable insulation applicability

ECSS-E-ST-20_0020427

- a. Reliable insulation requirements in this standard shall apply to all critical nets.

NOTE 1 Examples of critical nets are:

- non-protected sections of a main bus power distribution system up to and including the first overload or overcurrent protection device;
- cross-strapped power or signal critical lines or nets and associated common links,

connecting main and redundant circuits and matrices;

- lines or nets where short circuits would result into failure propagation of critical nature;
- lines or nets where basic insulation provisions may be damaged by mission environment or mechanical interference.

NOTE 2 Insulation loss due to mechanical interference is for example present when there are sharp edges and there is the need for harness protection.

NOTE 3 For Reliable Insulation rules for PCBs, refer to ECSS-Q-ST-70-12.

NOTE 4 For a solar array, it is assumed that Reliable Insulation requirements apply to lines carrying the current of a section because they are critical; otherwise the Reliable Insulation requirements are tailored in an appropriate way, for example by increasing solar array capability allowing loss of at least one section.

4.2.1.2.3 Reliable Insulation requirements

ECSS-E-ST-20_0020428

- a. For those space applications where electrical lines insulation can be damaged by meteorites or micro-meteorites, dedicated Reliable Insulation requirements or agreed equivalent solution shall be established before satellites development according to the environment encountered and to the required reliability figure at system level.

ECSS-E-ST-20_0020429

- b. The presence of foreign particles inside equipment, subsystem or system shall be treated as a credible event.

NOTE 1 Example of foreign particles are the materials used for manufacturing, piece of wire, nuts, washers, components and pins.

NOTE 2 Visual inspection is normally done to avoid the presence of foreign conductive particles that can create loss of insulation. Such particles might be there before equipment/subsystem /system closure or integration, or being the result of vibration exposure due to poor fixation. Potential particles and the activities that leads to emerging of these particles are identified and control plan is created if needed.

NOTE 3 Visual inspection is done on equipment, subsystem or system level before final assembly to avoid the presence of such particles that might create loss of insulation.

NOTE 4 The visual inspection method used is compatible with the minimum size of the particle to be detected.

ECSS-E-ST-20_0020430

- c. The non-existence of foreign particles shall be verified by visual inspection or test.

ECSS-E-ST-20_0020431

- d. The presence of foreign particles shall be assessed, recorded in the DJF, and resolved if not compatible with the application.

ECSS-E-ST-20_0020432

- e. All conductive elements of critical nets shall be provided with insulation means.

NOTE Insulation means are intended as insulating coating, or confinement of bolted connections or conductor inside insulation box (for example in the case of bus bars). Distance alone is not considered as a valid insulation means.

ECSS-E-ST-20_0020433

- f. Requirement 4.2.1.2.3e shall not apply to:
1. Solar Array solar cells, by-pass diodes, conductive coverglasses, solar cell interconnectors, blocking diode assembly and terminations, where no insulating material apart from vacuum is present among them,
 2. Solar Array Drive Mechanism slip rings, and
 3. Battery cell technologies for which loss of insulation is covered by other specific provisions.

NOTE For example NiH₂.

ECSS-E-ST-20_0020434

- g. To ensure an effective insulation from dielectric point of view, the gap among critical lines or between a critical line and any other conductor shall comply to the following two cases, for operational voltages up to 250 V:

1. Case 1: invariable gap greater than 1mm : use of 1 insulating material (non-gaseous / non-vacuum);
2. Case 2: variable gap or gap smaller than 1mm : use of 2 different materials (including at least 1 rigid).

NOTE 1 For rigid material, see requirements 4.2.1.2.3o and 4.2.1.2.3p.

NOTE 2 In case 2, two different materials or two layers of individually cured material are used.

NOTE 3 In the few particular cases where no suitable insulation layer can be added, the distance between the critical potential and any other potential is increased and guaranteed. The absence of risk of a particle with a size that could jeopardize the insulation at that level is guaranteed by inspection and by design (e.g. quasi-hermetic area).

ECSS-E-ST-20_0020435

- h. The worst case minimum thickness of the materials for reliable insulation shall be taken into account, and not their nominal or design values.

ECSS-E-ST-20_0020436

- i. It shall be demonstrated that no critical air bubbles to cause discharges are present in adhesives.

NOTE 1 The absence of critical air bubbles in adhesives is demonstrated by a quality control sample and DPA.

NOTE 2 Adhesives are normally not considered as insulators for reliable insulation purposes.

ECSS-E-ST-20_0020437

- j. The physical implementation of the reliable insulation shall be documented and recorded.

NOTE The implementation of reliable insulation is provided either in a project specific or in a standard document from the equipment provider and recorded in the respective manufacturing documentation (e.g. traveler or inspection record).

ECSS-E-ST-20_0020438

- k. The rigid and non-rigid materials used to ensure reliable insulation shall be listed in the document mentioned in 4.2.1.2.3j with their thickness and characteristics or the reference to the respective ESCC standard be indicated.

NOTE As an information on rigid and non-rigid materials, consult Table 4-1.

Table 4-1: List of rigid and non-rigid materials

Material	Characteristic
Epoxy fiberglass	Rigid (thickness $\geq 100 \mu\text{m}$)
PEEK	Rigid (thickness $\geq 100 \mu\text{m}$)
ULTEM Polyetherimide (PEI)	Rigid (thickness $\geq 100 \mu\text{m}$)
DURATRON Polyetherimide (PEI)	Rigid (thickness $\geq 100 \mu\text{m}$)
KYNAR (shrinkable sleeves)	Rigid
Epoxy FR4 laminate and pre-preg	Rigid
Polyimide laminate and pre-preg	Rigid
Ceramic (no crack risk under constraint)	Rigid
Scotchweld EC2216 (epoxy resin)	Rigid
Enamel grade 2	Rigid
Araldite AW 139 (epoxy resin)	Rigid (thickness $\geq 100 \mu\text{m}$)
Stycast 2850FT and 2651 (epoxy resin)	Rigid (thickness $\geq 100 \mu\text{m}$)
Kapton	Rigid (thickness $\geq 50 \mu\text{m}$)
Solithane 113 + cabosil (silice load) used as resin	non-rigid
Mapatox41B varnish (PCB conformal coating)	non-rigid
DC 93500 (varnish)	non-rigid
DC 6-1104 (thick varnish)	non-rigid
Cho-therm T500 and R1671	non-rigid
TIM (thermal material interface)	non-rigid
RTV silicon	non-rigid
Mapsil 213	non-rigid
Enamel grade 1	non-rigid

ECSS-E-ST-20_0020439

1. The electrical insulation materials shall have a dielectric strength in excess of 2 times the peak operative voltage in the actual application.

NOTE As a reference, the dielectric strength value of Air (3 kV/mm) can be used as selection criterion for materials.

For resistivity, typical value is $10E9 \text{ Ohm.m}$.

The selection of insulation material needs to take into account potential charging/ESD constraints (see ECSS-E-ST-20-06).

ECSS-E-ST-20_0020440

- m. The electrical insulation materials shall be resistant to the different phases of the unit MAIT (Manufacturing, Assembly, Integration and Test) process.

ECSS-E-ST-20_0020441

- n. Materials used in direct contact between 2 parts to be reliably insulated and between which an electrical field is present, shall not be contaminated, or contain other non-homogeneous pathway for leakage current to develop in clean room conditions, with max 65 % RH.

NOTE For instance, epoxy fiberglass or laminate/pre-preg can be procured against standards that allow some contamination to be present. Other types of non-homogenous pathway could be caused by agglomeration of fillers or flame retardant.

ECSS-E-ST-20_0020442

- o. In relation to reliable insulation, a material shall be treated as rigid if its Vickers hardness is greater than 20, either in raw state or after treatment.

ECSS-E-ST-20_0020443

- p. In relation to reliable insulation and in alternative to requirement 4.2.1.2.3o, a material shall be considered as rigid if the insulation layer produced with it can guarantee the required minimum thickness, for all required operative conditions including manufacturing and test process.

NOTE The required minimum thickness is guaranteed either by process or by verification.

ECSS-E-ST-20_0020444

- q. For critical lines and nets involving voltages exceeding 250 V, a minimum of 2x the distance identified by a dedicated analysis shall be used.

NOTE The dedicated analysis is performed to demonstrate the ability to cope with HV effects for critical nets.

ECSS-E-ST-20_0020445

- r. For critical lines and nets involving voltages exceeding 250 V, insulation shall be demonstrated by test with the application of 2x the operational voltage limit.

ECSS-E-ST-20_0020446

- s. A foreign particle should not jeopardise one insulation layer of the reliable insulation.

ECSS-E-ST-20_0020447

- t. Conductors with sharp edges, or geometries preventing the access to conformal coating shall be locally insulated with suitable material.

NOTE Example of geometries with difficult access are pins of PCB connectors or bus bars, components leads end (at PCB verso).

ECSS-E-ST-20_0020448

- u. Where the use of shielded wires and/or over-shielded harness together with reliable insulation is required:
 - 1. the issue shall be brought to customer attention, and
 - 2. the absence of any short-circuit risk between wire core and shield shall be demonstrated all along the harness, as well as at shield grounding connection points.

NOTE It is best practice not to use shielded or over-shielded harness and wires for signals to be reliable insulated.

ECSS-E-ST-20_0020449

- v. In case flexible connections are used, i.e. flex PCBs, the applicable requirements of clause 8 of ECSS-Q-ST-70-12 shall be applied.

ECSS-E-ST-20_0020450

- w. In the connectors mating area, the risk of short-circuit between a pin to be reliably insulated and a conductor at any other potential, due to a particle or to a bent pin shall be avoided.

NOTE 1 For example, conductor at any other potential can be a pin at a different potential or connector metallic case.

NOTE 2 Such short-circuit risk can be mitigated either by design (interfacial seal implementation, provision of not mounted pins locations, no risk of pin bending by design) or by inspection (absence of particle).

ECSS-E-ST-20_0020451

- x. Critical lines and nets shall be identified as part of a FMECA process or of a dedicated analysis at the beginning of the system, subsystem or equipment development, at relevant PDR at the latest.

ECSS-E-ST-20_0020452

- y. A dedicated analysis shall confirm that reliable insulation of critical lines or nets is not jeopardized by failures, at system, subsystem or equipment level.

NOTE Failures can be of electrical, thermal or mechanical nature (for example issues of interference especially in integration and manufacturing phases). Dissipative failures are part of the analysis required.

ECSS-E-ST-20_0020453

- z. Critical lines or nets shall be clearly identifiable in electrical diagrams and in layout and assembly drawings.

NOTE The critical lines are preferably identified for example with colour codes on assembly drawings or, if not possible, via a statement or note on the drawing.

ECSS-E-ST-20_0020454

- aa. The electrical diagrams, layout and assembly drawings providing the information of the critical lines or nets may be part of the relevant analysis report.

ECSS-E-ST-20_0020455

- bb. Compliance to Reliable insulation requirements of critical lines or nets shall be verified by review of design as well as by inspection and/or by test if possible.

NOTE The method of verification is matter of agreement between customer and supplier.

ECSS-E-ST-20_0020456

- cc. Verification of reliable insulation requirements should take place any time when it might be jeopardised by integration or rework activities, exposure to specific environment, electrical connection or disconnection.

4.2.2 Data processing

4.2.2.1 Overview

All operational and mission specific data are processed for acquisition, algorithm application, transmission, storage. On board time is managed by data handling subsystem, in line with the mission requirements. Data processing includes the man machine, interface if any. The data processing system includes all hardware and software elements used for that purpose (e.g. microprocessor and its instruction set, interface means, data busses and remote terminals).

4.2.2.2 Provisions

ECSS-E-ST-20_0020044

- a. For technical budgets and margin policy the requirements of ECSS-E-ST-10 clause 5.4.1.2 shall be applied.

ECSS-E-ST-20_0020388

- b. The margin for available memory size and load factors of processors should be
 1. for new developments, 50 % as a minimum at PDR for new on board software parts;
 2. 25 % at launch.

ECSS-E-ST-20_0020389

- c. The margin on the throughput of on-board communication networks should be
1. for new developments, 50 % as a minimum at PDR on the average throughput;
 2. such that real time overflow is avoided.

ECSS-E-ST-20_0020390

- d. In the absence of specific mission requirements the following applies: After error correction, reset or data corruption of main functions at equipment level should be kept to a rate of occurrence less or equal to 10^{-4} per day for worst case conditions of environment.

ECSS-E-ST-20_0020391

- e. For programmable logic devices (FPGA), the available margin of unused blocks and pin shall be agreed at FPGA SRR based on design complexity, requirement stability and experience return.

NOTE 1 To consider experience return, a factor of heritage of each block/IP can be used to multiply the estimated occupancy to have at the end, an overall occupancy < 100%. Possible example of heritage factor are:

- completely new component: 40 %
- full heritage for code, but ported to another technology: 25 %
- full heritage for both code and technology: 10 %

If the requirement are not stable or possible modification to accommodate future products/designs need are foreseen, a factor can also be applied to the overall design (i.e. 10 %).

NOTE 2 Design is highly re-used (> 80 % of the overall design), technology is mature (i.e. RTAX2000) and requirements are considered stable.

- A margin of 20 % is not considered a high risk.
- A margin of 10 % is still acceptable, but a mitigation plan can be requested (i.e. identifying some functions that can be removed or optimised, check if a pin-compatible bigger device is available, etc.)

NOTE 3 Most of the design is new and it is be implemented in relatively new technology (i.e. RTG4).

- In this case the risk related to low margin is much higher and a margin lower than 40 % is considered high risk. The risk can be assessed, the cost/benefit relation be evaluated and eventually the device selection might be re-assessed.

4.2.3 Electrical connectors

ECSS-E-ST-20_0020049

- a. A connector carrying source power or external test connectors on units shall have no contact areas exposed to possible short circuit during mating and de-mating process.

NOTE They generally are female type connectors.

ECSS-E-ST-20_0020050

- b. All external test connectors on a unit and spacecraft skin connectors shall be covered for flight.

NOTE Umbilical connectors (detached during launch) are not part of skin connectors (detached or connected before launch).

ECSS-E-ST-20_0020392

- c. The test connector covers should be metallic or metallized and grounded to structure.

ECSS-E-ST-20_0020052

- d. The use of a connector saver for ground testing shall not alter the performance of the equipment.

NOTE RF savers are known to introduce extra insertion losses, in the range of 0,1 dB.

ECSS-E-ST-20_0020053

- e. It shall be ensured that erroneous mating is avoided by connector keying or marking.

NOTE The requirement is met either by harness routing, or by using keyed connectors, or adequate positioning of connectors, or connectors of different type or size, or connector marking.

ECSS-E-ST-20_0020054

- f. If the equipment has several connectors, visibility and clearance around each of them should be such as to enable mating or de-mating without disturbing others already in place or necessitating custom-made tooling.

NOTE A usual practice is the insertion of a breakout box for trouble shooting.

ECSS-E-ST-20_0020393

- g. For supplies and signals of pyrotechnics and non-explosive single shot device drivers, different connectors should be used for different classes of electrical functions.

ECSS-E-ST-20_0020056

- h. When 4.2.3g is not met, power, signals, and telemetry shall be separated in the connector by a set of unused pin locations.

ECSS-E-ST-20_0020057

- i. Except when pin allocation is imposed by a standard specification, spare contacts or sockets should be available on each connector.

ECSS-E-ST-20_0020058

- j. For new developments, when the connection is not aligned to a defined standard, 10% spare contacts at unit PDR and at least 5 % at CDR shall be achieved with in any case a minimum of two spare contacts available at CDR.

ECSS-E-ST-20_0020059

- k. In the absence of grounding provision at connector shell level, at least one contact per connector shall be connected to the unit structure as provision for potential additional grounding at subsystem or system level.

ECSS-E-ST-20_0020060

- l. Provision shall be taken to avoid arcing or short circuits in connectors.

NOTE For example: unused pins, placed between positive and return lines; specific connector design.

ECSS-E-ST-20_0020061

- m. The following shall be performed for any connector the loss of which can lead to the loss of the mission:
 - 1. Document the connector in the single point failure list
 - 2. Verify and document its integrity up to the highest spacecraft integration level, to avoid accidental demating.

ECSS-E-ST-20_0020062

- n. <<deleted>>

ECSS-E-ST-20_0020063

- o. Battery and solar array power shall be distributed by multiple contacts on both positive and return lines.

4.2.4 Testing

ECSS-E-ST-20_0020064

- a. Test-stimulus points shall be accessible without the need of modifying the electrical configuration of an item of equipment.

ECSS-E-ST-20_0020065

- b. Test-stimulus points shall be protected for flight operation.

ECSS-E-ST-20_0020394

- c. For the purpose of meeting requirement 4.2.4a and 4.2.4b, dedicated test connectors should be used.

ECSS-E-ST-20_0020067

- d. <<deleted>>

ECSS-E-ST-20_0020068

- e. Test points on equipment shall be protected against damage up to the maximum fault voltage present on the connector either coming from the equipment or the EGSE.

NOTE It is expected that the design of the EGSE incorporates protections limiting the fault voltage emission to a level acceptable by the unit.

ECSS-E-ST-20_0020069

- f. Test points on equipment shall be such that unintentional connection of these points to ground does not damage the equipment.

ECSS-E-ST-20_0020070

- g. The redundancy of parts and functions, which failure can lead to the loss of the mission or human injury, shall be verified by test simulating the failure event.

ECSS-E-ST-20_0020071

- h. Circuits meant for on-ground testing or unused circuits shall not create or be sensitive to the noise expected during operation.

NOTE For example spacecraft stimuli, unit test points, unused operational amplifiers or comparators.

ECSS-E-ST-20_0020072

- i. The protection of functions, which failure can lead to the loss of the mission or human injury, shall be verified by test simulating the failure event.

ECSS-E-ST-20_0020073

- j. The test of a protection function or a redundant function shall present no risk of stress or failure propagation due to the injection of stimuli.

ECSS-E-ST-20_0020074

- k. <<deleted>>

ECSS-E-ST-20_0020075

- l. Hot redundant functions and protection functions that cannot be tested beyond unit level shall be identified in the critical item list.

ECSS-E-ST-20_0020076

- m. All redundant functions and protection functions shall be tested, up to the highest possible level of integration of the unit.

ECSS-E-ST-20_0020077

- n. Redundant units within a system shall be verified by test at system level.

ECSS-E-ST-20_0020078

- o. Protection functions within a unit protecting other units shall be verified by test at system level or at unit level with representative interfaces.

NOTE 1 This is the case e.g. of a battery discharge regulator switching OFF autonomously at low input voltage to protect a Li-ion battery against irreversible damage to overdischarge.

NOTE 2 In the case of the LCL in power distribution, the limitation of current at turn-on is considered representative for validation of the protection at system level.

4.2.5 Mechanical: Wired electrical connections

ECSS-E-ST-20_0020079

- a. Wired electrical connections shall contain stress relief.

NOTE The objective is to avoid excessive mechanical loads on wires.

4.2.6 Miscellaneous

ECSS-E-ST-20_0020080

- a. Each item shall be directly interchangeable in form, fit, and function with other equipment of the same part number and of the same qualification status.

ECSS-E-ST-20_0020081

- b. The uniformity of the electrical performance characteristics of the units shall enable equipment interchange provided a minimum set of adjustments and recalibration as described in the unit user's manual.

ECSS-E-ST-20_0020082

- c. When components operating in a single event are used, 4 times the quantity to be used for flight units shall be procured as one lot: 25 % for the lot acceptance test, 25 % for flight use, 25 % for spares and 25 % for a confirmation test near to the launch date.

NOTE Example of such components are fuses.

ECSS-E-ST-20_0020083

- d. The number of components to be procured shall be defined to ensure, as a minimum, the quantity needed for flight and flight spares, plus the number of components to be tested at incoming reception and components to be tested just before launch in case of alert or failure.

4.3 Verification

4.3.1 Provisions

ECSS-E-ST-20_0020084

- a. The requirements of this Clause 4 should be verified by the verification methods and at the verification points listed in Table 8-3.

NOTE 1 Table 8-3 can be used as a starting point for the definition of the verification methods.

NOTE 2 For more details on the verification strategy see also ECSS-E-ST-10-02 in particular the requirements 5.2.1c, d and e.

ECSS-E-ST-20_0020408

- b. In case verification by analysis of an electrical part or circuit is not possible by lack of data, complementary verification by test shall be performed.

NOTE Electrical part or circuit encompasses in particular to EEE components, solar cell or solar array, battery cell or battery assembly.

4.3.2 Documentation

ECSS-E-ST-20_0020085

- a. The design report, PSA, WCA, FMECA, thermal analysis, radiation analysis, EMC analysis and the detailed circuit diagrams including component values, shall be part of the Design Definition and Justification Files.

ECSS-E-ST-20_0020086

- b. Failure modes of all components used in a unit shall be defined.

ECSS-E-ST-20_0020087

- c. FMECA shall be performed and based on the failure modes previously defined at component level.

ECSS-E-ST-20_0020409

- d. The Design Definition and Justification Files shall be delivered by the supplier to the customer at the agreed verification points in compliance with Table 8-3.

ECSS-E-ST-20_0020380

Table 4-1: <<deleted, merged with new Table 8-3>>

5

Electrical power

5.1 Functional description

Electrical power is used by all active spacecraft systems and equipment for their operation. Electrical power engineering includes power generation, energy storage, conditioning, line protection and distribution as well as high voltage engineering.

5.2 Power subsystem and budgets

5.2.1 General

ECSS-E-ST-20_0020088

- a. Budgets and margins shall be established during Project phase B, and reviewed in all subsequent phases of the project.

5.2.2 Provisions

5.2.2.1 Power subsystem

ECSS-E-ST-20_0020089

- a. The power subsystem of a spacecraft shall be able to generate, store, condition, distribute and monitor the electrical power used by the spacecraft throughout all mission phases in the presence of all environments actually encountered.

NOTE For passivation, refer to ECSS-U-AS-10.

5.2.2.2 Engineering process

ECSS-E-ST-20_0020090

- a. An analysis of power demand versus power available shall be performed, including average peak power, for all phases of the mission.

ECSS-E-ST-20_0020091

- b. An analysis of the energy demand versus energy available shall be performed in all phases of the missions, including inrush power demands, eclipses, solar aspect angle and depointing and also failure mode affecting the power system.

NOTE Failure modes can result in transient or permanent overconsumption.

ECSS-E-ST-20_0020092

- c. A power budget shall be established based on the peak power values and an energy budget based on the average power values for all mission phases.

ECSS-E-ST-20_0020093

- d. A plan shall be established for the maintenance and periodical review of the budget established in requirement 5.2.2.2c during all project phases.

NOTE These budgets take into account:

- spacecraft–sun distance,
- sun and eclipse durations,
- solar aspect angle,
- shadowing,
- pointing accuracy,
- environmental temperature and degradation effects,
- reliability and safety aspects,
- any one failure in the system (two failures for manned mission) not counting solar array string and battery cell failure, that are provisioned for achieving reliability of these item, but including transient or permanent overconsumption of a load,
- Failure detection, isolation and recovery scenarios.

ECSS-E-ST-20_0020094

- e. A system margin of not less than 5 % at AR on available power and energy shall be included in the budget, available (as a minimum) with the solar array string losses as defined by the customer with the minimum of one string lost and one battery cell failed during all the designed life of the power system including all spacecraft modes of operation.

ECSS-E-ST-20_0020095

- f. When actually using a MPPT, it shall be ensured that the transferred power is at least the required power, independent of the solar array operating conditions or environment.

NOTE The factors affecting the transferred power include in particular the following ones:

- Consideration of possible multiple local maximum power points,
- Different illumination (e.g. resulting from different SAA) for different SA sections,
- Temperature dispersion,
- Shadowing,

- Dispersion of the SA string I/V curves,
- Tracking accuracy and response time of MPPT control,
- Dynamic stability of MPPT control loop,
- Power conversion efficiency of MPPT converters.

5.3 Failure containment and redundancy

ECSS-E-ST-20_0020096

- a. Any protection function of a power converter or regulator preventing failure propagation shall:
1. not be implemented in the same integrated circuit, and
 2. not utilize common references.

ECSS-E-ST-20_0020097

- b. It shall not be possible to inhibit a protection feature if such an inhibition can lead to the loss of the main primary power bus in case of a single failure at spacecraft level.

ECSS-E-ST-20_0020098

- c. In flight operation, if primary power bus shutdown happens, the system, including the power subsystem, shall be able to restart.

NOTE 1 Startup is possible as soon as sufficient power is available for a sufficient time from any source of the primary power bus, without considering failure for unmanned mission, or after single failure for manned mission.

NOTE 2 This requirement can imply that the battery is sufficiently recharged before its energy starts to be provided, for example to recover spacecraft attitude.

ECSS-E-ST-20_0020099

- d. <<deleted>>

5.4 Electrical power interfaces

ECSS-E-ST-20_0020100

- a. The electrical power interface internal or external to the power subsystem shall be specified, including source and load impedance.

NOTE Main examples of internal power interface are battery to conditioning electronics, SA to conditioning electronics. Main examples of external power interface are primary power conditioning electronics to loads, EGSE to and from primary power conditioning electronics, umbilical to and from primary power conditioning electronics. Docked modules on board of spacecraft, like orbiter or rover, are concerned as well.

ECSS-E-ST-20_0020101

- b. <<deleted>>

ECSS-E-ST-20_0020102

- c. The availability of the specified solar array power up to the power conditioning electronics shall be verified as follows:
1. on solar array level, availability of the specified solar array power up to and including the solar array connector by means of flasher tests, supported by correlated analysis,
 2. on spacecraft level, full steady-state solar array power conditioning capability from solar array connector to power conditioning electronics, including solar array drive mechanism if any and harness, using solar array simulator,
 3. and finally, on spacecraft level, correct electrical connection of the solar array to the power conditioning unit by means of a flood test, that is by illumination of the solar array with a portable continuous lamp, checking if the generated voltage and current are detected at power conditioning side.

ECSS-E-ST-20_0020103

- d. The solar array interface voltage shall be defined at the solar array connector interface.

ECSS-E-ST-20_0020104

- e. The solar array interface voltage shall include voltage losses within the electrical circuitry of the solar array, including at least blocking diodes, wiring resistance and losses associated with harness interconnections in operational conditions.

5.5 Power generation

5.5.1 Solar cell, coverglass, SCA and PVA qualification

For the qualification of solar cells, protection diodes, coverglass, SCA and PVA, see ECSS-E-ST-20-08.

5.5.2 Solar array specification and design

ECSS-E-ST-20_0020105

- a. The solar array shall be specified to provide the requested power and ensure the energy balance in each mission phase during operational life including any string loss tolerance defined by the customer, spacecraft charging effects and worst case conditions.

NOTE 1 The solar array is designed to be single-failure tolerant at string level.

NOTE 2 In order to meet the solar array reliability requirements, the impact of other loss factors can lead to the addition of other spare strings.

NOTE 3 The computation of the energy balance is a typical task for the large system integrator based on defined power points expressed as a specification to the SA manufacturer.

ECSS-E-ST-20_0020106

- b. <<deleted>>

ECSS-E-ST-20_0020107

- c. <<deleted>>

ECSS-E-ST-20_0020108

- d. Provision shall be made against potential failure propagation in case of short-circuit failure of a solar array section or short circuit of its connection to the power subsystem.

NOTE In particular short-circuit of solar array interface (for example during ground operations) can lead to short-circuit of the main bus or the battery if no protections (e.g. blocking diodes in conditioning electronics) are implemented.

ECSS-E-ST-20_0020109

- e. The solar array design shall be such that charging phenomena do not degrade the performance of the solar array below the ones specified in 5.5.2a and meeting the requirements specified in clauses 5.5.1.5 of ECSS-E-ST-20-08.

ECSS-E-ST-20_0020110

- f. The following requirements and omissions for ESD shall apply:
1. ESD testing is performed.
 2. ESD testing is be performed in line with ECSS-E-ST-20-06 and ECSS-E-ST-20-08 demonstrating minimum safety margins as specified in clauses 5.5.1.5.of ECSS-E-ST-20-08.
 3. ESD testing of solar arrays can be omitted for solar arrays with voltage less than or equal to 10 V, independent of current and gap distance.
 4. For voltages below 30 V ESD testing can be omitted as well, provided the current remains below 0,6 A and gap width above 0,9 mm.

ECSS-E-ST-20_0020111

- g. In all configurations, stowed and deployed, the solar array , deployable and body mounted, and spacecraft structure shall be insulated from each other, disregarding the bleed resistor.

NOTE 1 Examples of such structural parts of the SA panel are hold-down mechanisms, yokes, hinges and CCL (Closed Cable Loop).

NOTE 2 Typical value of insulation is in the order of 100 M Ω , and typical bleed resistor is in between 2 k Ω to 20 k Ω .

ECSS-E-ST-20_0020112

- h. In the flight configuration, means to prevent differential voltage due to electrostatic charging between solar array structure and the spacecraft electrical ground reference shall be implemented.

ECSS-E-ST-20_0020113

- i. In the flight configuration, bleeding resistors shall be implemented.

NOTE 1 For typical solar array designs the panel substrate is conductive and mounted electrically insulated from the Spacecraft structure. In order to control the charging of the solar array substrate(s), the panel substrates are connected via bleeder resistors to spacecraft ground.

NOTE 2 Bleeding resistors are used to control both electrostatic charging and power loss from the solar array section and dissipation in the resistor itself in case of a cell string to panel short (including de-rating).

NOTE 3 Bleeding resistors can be considered as a separate protection together with a parallel insulating material in view of reliable insulation (reliable double protection).

ECSS-E-ST-20_0020114

- j. At solar array level, one short between a solar cell string and a conductive panel structure shall not produce any solar array power loss.

ECSS-E-ST-20_0020115

- k. At solar array level, in case of two shorts on the same panel, the power loss shall not be more than the power of two strings.

ECSS-E-ST-20_0020116

- l. The PVA layout shall be designed to meet the solar array magnetic moment requirements.

ECSS-E-ST-20_0020117

- m. <<deleted>>

ECSS-E-ST-20_0020118

- n. <<deleted>>

ECSS-E-ST-20_0020119

- o. Provision shall be made to prevent failure due to operation in shadow.

ECSS-E-ST-20_0020120

- p. Solar array shall be designed in sections according to the redundancy principle specified at system level.

NOTE 1 The number of sections can be equal to one or to the number of strings, depending on the redundancy principle.

NOTE 2 Sectioning the SA can alleviate failure mitigation constraints.

ECSS-E-ST-20_0020121

- q. Solar cells shall be protected against any deleterious reverse-bias conditions.

ECSS-E-ST-20_0020457

- r. The conductive panels substrates shall be electrically insulated from each other and from the other structural parts of the solar array.

NOTE An examples of other structural parts is yoke.

ECSS-E-ST-20_0020458

- s. For the purpose of insulation in solar arrays the following shall not be considered as a valid insulating layer:

1. Silicone based adhesives
2. Conformal coatings

NOTE 1 Examples of silicon based adhesives are RTV-S 691, CV10-2568, RTV-S types, DC 93500. Examples of conformal coatings are Sulphur based compounds and silicone dioxide.

NOTE 2 Issues of silicone based adhesives is the combination of their hygroscopic characteristics, the potential humidity absorbed on ground, the deposition layout and process, the severe thermal cycling and the radiation environment.

NOTE 3 Silicone based adhesives can still be employed as insulation material for solar panel connectors. Good practice is to group the polarities and to separate them inside connectors as much as possible.

ECSS-E-ST-20_0020459

- t. Insulation of solar array wires shall be provided with two different layers of materials or use of 2 individually cured layer of materials.

ECSS-E-ST-20_0020460

- u. All individual electrical elements of the solar array shall be reliably insulated with respect to the ground of the spacecraft.

NOTE An example of an element of the solar array is the solar cell.

5.5.3 Solar array power computation

ECSS-E-ST-20_0020122

- a. Computation of solar array power shall be based on measurements at cell level performed in accordance with the requirements of clause 10 of ECSS-E-ST-20-08.

ECSS-E-ST-20_0020123

- b. The model used for the computation of the I(V) curve of the solar cell shall be validated by test on the specific solar cell type for the mission in conditions representative of the expected domain of operation.

NOTE Representative conditions are, for example, illumination, temperature or SAA.

ECSS-E-ST-20_0020124

- c. I(V) solar cells characteristics shall be computed in BOL and EOL conditions at maximum and minimum operating temperatures according to the mission profile.

ECSS-E-ST-20_0020125

- d. The EOL solar cell I(V) curve shall be derived from measurements performed at the temperatures specified in 5.5.3c after irradiation with particles in conformance with the “Electron irradiation” and “Proton irradiation” tests for “Bare solar cells” specified in ECSS-E-ST-20-08 clause 7, and agreed with the customer.

NOTE The irradiated particles can either electrons or protons. The irradiation particles can be electrons or protons, chosen in order to facilitate the calculation of degradation, ideally using the particle type that dominates the degradation during the mission.

ECSS-E-ST-20_0020126

- e. The forward voltage of the string blocking diode (if present) shall be computed:
1. using the worst-case voltage drop specified by the diode manufacturer,
 2. at the diode operating temperature corresponding to the operational string current for each mission phase in worst case conditions.

ECSS-E-ST-20_0020127

- f. The BOL worst and best case power calculations shall include the parameters indicated in Table 5-1.

ECSS-E-ST-20_0020128

- g. For best case calculations, the string current shall account for the difference between the specified current and the average production value.

ECSS-E-ST-20_0020129

- h. In addition with the parameters indicated in Table 5-1, the EOL worst and best case calculations shall include the parameters indicated in Table 5-2.

ECSS-E-ST-20_0020130

- i. Shadowing and hot spot phenomena shall be analysed.

ECSS-E-ST-20_0020131

- j. Leakage losses of bypass diodes shall be deducted from the power computation if they represent more than 0,1 % of the overall power to be provided.

ECSS-E-ST-20_0020132

- k. Plume impingement effects shall be analysed.

Table 5-1: Parameters for BOL worst and best case power calculations

Parameter	Applicable to string	Type of loss/gain
Current Cell mismatch	Current	Random
Calibration error ^a	Current	Random
Cover glass gain / loss	Current	Direct
Blocking Diode Loss	Voltage	Direct
Harness Voltage Drop	Voltage	Direct
Pointing error due to disorientation and internal Solar Array error	Current	Direct
Orbital Losses & Sun Intensity ^b	Current & Voltage ^c	Direct
Shadow losses ^d	Current & Voltage	Direct
Temperature coefficient ^e	Current & Voltage	Direct
Temperature Gradient on String	Current & Voltage	Direct
^a Typical value is $\pm 3\%$, including secondary working standard calibration and bare solar cell measurement accuracies, ^b Orbital losses as; EQX/SS, altitude, inclination, albedo, solar array angle including the cosine law deviation ^c E.g. High/Low Intensity interplanetary mission ^d E.g. Voltage losses due to cells and solar cell shunt diodes ^e For the average operational temperature on orbit $\pm 5^{\circ}\text{C}$.		

Table 5-2: Additional power parameters for EOL worst and best case calculations.

Parameter	Applicable to string	Type of loss/gain
UV degradation ^a	Current	Direct
Micrometeorites ^b	Current	Direct
"Loss of strings" tolerance	Current	Direct
Reliability of components and interconnection	Current & Voltage	Random
Degradation due to ESD Phenomena	Current & Voltage	Random
Solar array surface contamination	Current	Direct
Radiation ^c	Current & Voltage	Direct
^a Maximum loss is solar cell assembly dependent and are determined by testing. The degradation follows an exponential decay with main part of the degradation in the first year. ^b Depending of in-orbit available data for each type of cell. ^c See ECSS-E-ST-10-04, clause 9.2.		

5.5.4 Solar array drive mechanisms

ECSS-E-ST-20_0020133

- a. The qualified de-rated current capability of wires, connector pins and slip ring contacts shall be greater than the best case BOL solar array section current in short circuit and include the effects of transient currents caused by the discharge of the solar array section capacitance.

ECSS-E-ST-20_0020134

- b. The design of the insulation barriers between adjacent wires, connector pins and slip rings shall be such that no discharge phenomena can occur.

ECSS-E-ST-20_0020135

- c. Where non-insulated conductors are used, arcing phenomena shall be prevented by design.

5.6 Electrochemical Energy Storage

5.6.1 Applicability

For the purpose of this clause, a battery is defined as a device that converts the chemical energy contained in its active materials into electric energy by means of electrochemical oxidation-reduction (redox) reaction.

It is made-up of one or more electrochemical cells, which can be grouped in modules permanently connected in series or parallel.

Clauses 5.6.2 to 5.6.5 apply to primary and secondary batteries where reference is not made to charge. Clause 5.6.5 defines additional safety requirements for all battery types.

Fuel cells and super capacitors are not addressed by the present standard.

5.6.2 Batteries

ECSS-E-ST-20_0020136

- a. The battery shall be specified to ensure the energy balance in each mission phase during operational life, including contingency modes resulting from a single failure for unmanned missions and two failures for manned missions.

ECSS-E-ST-20_0020137

- b. <<deleted>>

ECSS-E-ST-20_0020138

- c. Specific measures shall be taken in the battery design to keep under control the series inductance and the magnetic moment.

ECSS-E-ST-20_0020139

d. <<deleted>>

ECSS-E-ST-20_0020140

e. Batteries having to tolerate a single fault shall be designed such that they can operate with one cell either failed shorted or open circuit.

ECSS-E-ST-20_0020141

f. In batteries having to tolerate a single fault and where the effects of a single cell failure are mitigated by the use of a cell bypass device, the following shall be met:

1. The probability of the bypass circuit untimely operation is lower than the probability of a failure of the cell.
2. If the bypass operation is not instantaneous, the power subsystem design is able to operate without damage during the transient situation.
3. The maximum number of cells that can be bypassed after a failure or a wrong command is equal to the number of failures allowed by the specific mission design.

ECSS-E-ST-20_0020142

g. Transient currents, occurring when two or more separate strings of series-connected cells are connected together in parallel, or when a cell fails in short-circuit within a battery composed of parallel strings, shall not result in exceeding the peak cell current rating.

ECSS-E-ST-20_0020143

h. Battery supplier shall:

1. specify cell to cell performance variations so that mission requirements can be met,
2. provide methodology and validation of cell performance variations for any spare or flight models.

NOTE Cells making-up a battery are selected (matched) in accordance with the cell manufacturer's requirements. Sufficient extra matched spare cells are procured to allow for replacement of any cells damaged during integration of batteries. If cells are not individually replaceable, then appropriately matched cell groups/modules are available. It is good practice to specify the number of spare cells in the battery procurement documentation.

ECSS-E-ST-20_0020144

- i. When batteries are discharged in parallel, this discharge shall not result in current and temperature exceeding the cell qualification limits.

NOTE This requirement is essentially applicable to primary Lithium batteries that have a positive voltage vs temperature coefficient.

ECSS-E-ST-20_0020145

- j. Conducting cases of battery cells in a battery package shall be insulated from each other [with reliable insulation](#).

NOTE See definition of “reliable insulation” in clause 3.2.

ECSS-E-ST-20_0020146

- k. Provisions for interfacing the battery with the ground support equipment during pre-launch operations shall be made.

NOTE Such provisions can include:

- signal lines for monitoring battery voltage,
- signal lines for monitoring battery temperature,
- capability to charge the battery,
- capability to discharge the battery.

ECSS-E-ST-20_0020147

- l. A logbook shall be maintained by the supplier for each flight battery starting with the first activation after battery assembly up to launch, describing chronologically all test sequences, summary of observations, identification of related computer-based records, malfunctions, and references to test procedures and storage conditions.

NOTE The logbook is used for the following purposes:

- to ensure compliance with storage, handling and operational requirements before launch (e.g. maximum time allowed at upper temperature limits, correct scheduling of maintenance activities);
- to allow verification of flight worthiness.
- special care has to be paid to external current discharge paths during integration phases.

ECSS-E-ST-20_0020148

- m. Battery and spacecraft thermal design shall ensure together that:
1. maximum and minimum qualification temperature of cell operation under intended cycling conditions are not exceeded;

2. maximum qualification temperature gradients between different parts of the same cell and between two cells in a battery are not exceeded.

ECSS-E-ST-20_0020149

- n. <<deleted>>

ECSS-E-ST-20_0020410

- o. Conductive cases of battery cells shall be **reliably** insulated from spacecraft structure, with an insulation between any cell and the spacecraft structure greater than 10 M Ω , measured at 500 V DC.

NOTE See definition of "reliable insulation" in clause 3.2.

5.6.3 Battery cell

ECSS-E-ST-20_0020150

- a. Absolute maximum ratings of the cell, in term of temperature, voltage, charge and discharge current in continuous and peak condition, shall be defined.

ECSS-E-ST-20_0020151

- b. The ability of a cell to meet mission lifetime requirements, where not covered by qualification life testing or previous in flight experience, shall be justified by the ground test data or by dedicated tests under representative conditions.

ECSS-E-ST-20_0020395

- c. The ability of a cell to meet mission life time requirements may be verified by similarity with qualification life testing or previous in flight experience only in case of identical design and identical manufacturing processes.

ECSS-E-ST-20_0020153

- d. For any intended cell operation under acceleration greater than 1 g, the supplier shall ensure that no effect upon both short term (e.g. capacity) performance and lifetime can prevent battery nominal operation.

ECSS-E-ST-20_0020154

- e. <<deleted>>

ECSS-E-ST-20_0020155

- f. <<deleted>>

ECSS-E-ST-20_0020156

- g. The battery supplier shall inform the customer of any change in design, materials or process from cells which have experienced life testing or flight.

5.6.4 Battery use and storage

ECSS-E-ST-20_0020157

- a. The design of the spacecraft shall be such that modules and batteries can be removed and replaced at any time prior to launch without affecting the acceptance status of the rest of the spacecraft.

ECSS-E-ST-20_0020158

- b. For the procurement of cells and batteries the manufacturer shall supply a user manual in conformance with Annex D.

ECSS-E-ST-20_0020396

- c. Flight batteries should not be used for ground operations to prevent any possible damage and subsequent degradation of life performance.

ECSS-E-ST-20_0020160

- d. If 5.6.4c is not met, the flight worthiness of the batteries shall be re-verified after these ground operations are completed, in time for a possible replacement.

NOTE Re-verification can be done e.g. by capacity measurements.

ECSS-E-ST-20_0020161

- e. Any test equipment interfacing with the battery shall include an associated undervoltage, overvoltage, overcurrent and over-temperature activated insulation switch.

ECSS-E-ST-20_0020162

- f. <<deleted>>

ECSS-E-ST-20_0020397

- g. <<deleted>>

5.6.5 Battery safety

5.6.5.1 Overview

Almost all battery technologies used aboard spacecraft can be hazardous if not properly managed. Most are capable of delivering very high currents when shorted. When abused, cells can develop excessive internal pressure and eventually vent their contents, in extreme cases explosively. The electrolyte, cell reactants, and/or reaction products expelled can be corrosive (e.g. alkaline cells, lithium-SO₂, Lithium SOCl₂), flammable (e.g. lithium cell organic electrolytes) or toxic endangering any nearby personnel as well as neighbouring equipment. The principal cell failure modes, which can lead to these effects, are listed in 5.6.5.2b.

Detailed descriptions of the hazards associated with different battery chemistry are given in reference document: Crew vehicle battery safety requirements, JSC-20793 Rev B April 06.

The design rules in earlier clauses which aim at maximizing battery performance and cycle life also reduce the possibility that cells and batteries exhibit failure modes such as those listed above. However, in applying the safety rules of ECSS-Q-ST-40, some battery failure modes are critical or catastrophic. Further design or management provisions are implemented to achieve the required level of fault tolerance.

For safety requirements related to pressure vessels see ECSS-E-ST-32.

5.6.5.2 Provisions

ECSS-E-ST-20_0020164

- a. The battery safety shall be managed in conformance with ECSS-Q-ST-40.

ECSS-E-ST-20_0020165

- b. The design of the battery and associated monitoring and control electronics shall preclude the occurrence of any of the following:
1. Over-temperature (from battery thermal dissipation or environmental heating);
 2. excessive currents (discharge or charge) including short-circuit (external or internal to the battery);
 3. overcharging;
 4. Attempt to charge in the case of primary cells;
 5. over discharge (including cell reversal);
 6. cell leakage (gases or electrolyte).

ECSS-E-ST-20_0020166

- c. Where 5.6.5.2b is not met, the design shall mitigate the damaging effects of any such failure mode

NOTE E.g. by containment of cell leakage at battery level.

ECSS-E-ST-20_0020398

- d. The failure of one or more cells within a battery due to imbalance in the state of charge, temperature or other parameter between cells should be prevented by the battery control electronics.

ECSS-E-ST-20_0020399

- e. When the battery has non-insulated, exposed cell terminals, the battery should be delivered with a red insulation cover to be removed before spacecraft closure and for flight.

ECSS-E-ST-20_0020400

- f. Provision should be made not to change the thermal balance of the battery during charge and discharge operations with the cover notified in 5.6.5.2e.

5.7 Power conditioning and control

5.7.1 Applicability

The requirements in 5.7.2 and 5.7.3 apply to power subsystems, those in 5.7.4 and 5.7.5 apply both to power subsystems and payloads, and those in 5.7.6 apply to payloads.

5.7.2 Spacecraft bus

ECSS-E-ST-20_0020170

- a. No single failure shall result in the loss of the power subsystem capability to the extent that the minimum mission requirements, in any of its phases, cannot be fulfilled.

ECSS-E-ST-20_0020171

- b. For manned missions, no double failure shall result in the loss of the power subsystem capability to the extent that the minimum mission requirements, in any of its phases, cannot be fulfilled.

ECSS-E-ST-20_0020172

- c. The primary power bus voltage regulation control for a fully regulated bus shall be independent from any control external to the electrical power subsystem.

NOTE 1 Main control features do not include parameter settings by the OBC.

NOTE 2 Loss of MPPT control can result in bus overvoltage hence the requirement concerns also MPPT control for regulated bus.

ECSS-E-ST-20_0020173

- d. The ultimate switching between main and redundant MPPT circuitry, in case of MPPT malfunction, shall be implemented in a way to avoid infinite reconfiguration loops.

NOTE 1 Autonomous MPPT can be implemented with redundancy and 2 out of 3 majority voter."

NOTE 2 Ultimate decision to switch over from nominal to redundant MPPT can depend on command from ground.

ECSS-E-ST-20_0020174

- e. No single failure in the spacecraft shall open or short a main electrical power bus or violate the specified over voltage or under voltage limit requirements.

NOTE This includes for example failure of wiring, connectors and relays.

ECSS-E-ST-20_0020175

- f. The design shall ensure that under all conditions during the required lifetime, including operation in eclipse with one battery cell failure and one solar array string failed, the primary bus voltage remains within specified performances.

ECSS-E-ST-20_0020401

- g. For fully regulated buses, the nominal bus voltage value should be standardized according to the following:

1. 28 V for power up to 1,5 kW;
2. 50 V for power up to 8 kW;
3. 100 V and 120 V for higher power.

NOTE 1 Bus voltage types are standardized in order to maximize the reuse of equipment.

NOTE 2 The rationale for this requirement is the following:

It is in practice difficult to design output impedance below 10 milliohm without an unwanted effect of the intrinsic connections and components resistance. For the design of a bus with 10 milliohm output impedance such that a 50 % load modulation induces a 1 % voltage change maximum as per 5.7.2i.1 requirement:

$$0,5 P/U \times 0,01 < 0,01U \text{ which means } P < U^2/0,5$$

Thus for $U = 28 \text{ V}$, $P < 1,57 \text{ kW}$

$U = 50 \text{ V}$, $P < 5 \text{ kW}$

$U = 100 \text{ V}$, $P < 20 \text{ kW}$

In practice, at 50 V for example, higher power has been used on telecom spacecraft buses, because the 1 % voltage change referred to a lower load change of 20 % to 30 % instead of 50 %.

ECSS-E-ST-20_0020177

- h. A fully regulated bus shall keep its nominal value in steady state within $\pm 0,5 \%$ of the bus voltage at the main regulation point.

ECSS-E-ST-20_0020178

- i. With a fully regulated bus in nominal operation the bus voltage transients shall:

1. for load transients of up to 50 % of the nominal load not exceed 1 % of its nominal value.
2. for any source and load transients remain within 5 % of its nominal value.

NOTE Load transient encompasses change of load current and ON/OFF load switching.

ECSS-E-ST-20_0020402

- j. Fuses should be avoided to maintain the quality of the bus.

NOTE The rationale for requirement 5.7.2h to 5.7.2j is the following:

In order to be advantageous over an unregulated scheme, a regulated bus ensures a good regulation quality at the regulation point, including when the various loads on the bus are changing. The regulated bus is designed to ensure that normal transients including interdomain are within 5% all included. Abnormal transients are more than twice the normal transients; the load is then designed to operate nominally in normal transients and sustain without damage abnormal transients.

ECSS-E-ST-20_0020180

- k. In case of fuse blowing, the recovery from the fuse clearance shall not produce an overshoot of more than 10 % above the nominal bus value.

ECSS-E-ST-20_0020181

- l. The model of the fuse and of the electrical network to be protected by the fuse, shall be validated by test with a representative set-up

ECSS-E-ST-20_0020182

- m. A fully regulated bus shall have a nominal ripple voltage below 0,5 % peak-to-peak of the nominal bus voltage, measured at the regulation point with at least 1 MHz bandwidth.

ECSS-E-ST-20_0020183

- n. A fully regulated bus shall have commutation voltage spikes in the time domain of less than 2 % peak-to-peak of the nominal bus voltage, measured at the regulation point with a 50 MHz minimum bandwidth.

ECSS-E-ST-20_0020184

- o. At the point of regulation, the impedance mask of a fully regulated bus, operating with one source shall be below the impedance mask shown in Figure 5-1.

NOTE 1 E.g. battery, solar array.

NOTE 2 Rationale for the impedance mask:

It translates requirement 5.7.2i.1 of 1 % voltage change for 50 % load change in a domain of regulation up to 10 kHz bandwidth. In DC the integrator in the control loop is designed to ensure no static error, in higher frequency, between 10 kHz and 100 kHz it is likely that the inductance effect of the components and

connections are seen and the impedance rise not always making feasible to respect the ideal impedance mask.

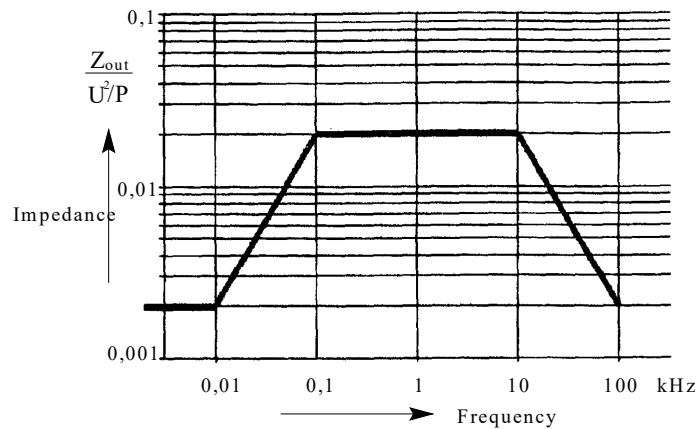

U = Nominal regulated output voltage (Volt)

P = Power capability (Watt)

ECSS-E-ST-20_0020383

Figure 5-1: Output impedance mask (Ohm)

ECSS-E-ST-20_0020185

- p. For unregulated buses, the following parameters shall be specified, analysed and tested:
1. maximum and minimum bus voltage guaranteed at payload level in all steady state and transients conditions;
 2. maximum ripple in time domain, measured with at least 1 MHz bandwidth.
 3. maximum spikes in the time domain superimposed on the bus voltage, measured with a 50 MHz minimum bandwidth.
 4. impedance mask.

NOTE Rationale for the requirement: Also for an unregulated bus, it is important to identify the bus impedance mask to verify the compatibility between the power bus and the loads, as for instance the guaranteed voltage range at bus level including the effects of load variations.

ECSS-E-ST-20_0020186

- q. During integration phase the power subsystem shall be able to start up from any of its power sources irrespective of the connection of the other power source.

ECSS-E-ST-20_0020187

- r. In the case of an unexpected battery or battery simulator disconnection, the main power bus voltage shall remain below its maximum specified overvoltage requirement.

NOTE 1 This requirement applies only to ground operations, it can be profitably fulfilled by the EGSE.

NOTE 2 This requirement can also apply in flight whenever a battery disconnection can occur as a result of ground command or single failure.

ECSS-E-ST-20_0020188

- s. The design shall ensure that a short circuit to ground or to the return line of a solar array section does not result in a failure of category 1 and 2 criticality.

NOTE The definition of criticalities can be found in ECSS-Q-ST-30 or ECSS-Q-ST-40.

ECSS-E-ST-20_0020411

- t. Control of the battery by OBC shall be robust to OBC failure and the time needed to reconfigure.

NOTE 1 This requirement concerns in particular battery bus.

NOTE 2 Issues include switch over from main to redundant OBC control, lack of protection during reconfiguration, battery overvoltage or overcurrent, battery undervoltage, loss of attitude, solar array MPPT operation on battery bus.

NOTE 3 Safety issues during integration and operations on ground including launch is to be covered by overall system design and EGSE.

5.7.3 Battery Charge and Discharge Management

ECSS-E-ST-20_0020189

- a. On-board battery chargers shall be designed to ensure charging of a battery discharged down to zero volts.

NOTE The possibility of recovery applies mainly to the capability of recharging the battery exposed to extreme discharge conditions.

ECSS-E-ST-20_0020190

- b. <<deleted>>

ECSS-E-ST-20_0020191

- c. The minimum energy reserve in the battery shall be enough to guarantee the mission and a safe recovery of the spacecraft under all conditions.

NOTE Take into account that the charge rate plays a major role in the effectiveness of battery recharge.

ECSS-E-ST-20_0020192

- d. The charging technique shall be designed to ensure that the batteries are managed in accordance with the manufacturer recommendations provided in the design description, justification file and user's manual.

NOTE To avoid over (or under) charge when taper charging is employed, the voltage limit above which taper charging begins can be adjusted as a function of temperature, ageing or other parameters, depending on the battery technology. In some missions, required lifetime can only be obtained if the taper charge limit is lowered during periods of no or little battery use.

ECSS-E-ST-20_0020193

- e. <<deleted>>

ECSS-E-ST-20_0020194

- f. <<deleted>>

ECSS-E-ST-20_0020195

- g. <<deleted>>

ECSS-E-ST-20_0020196

- h. The ultimate over charging/discharging protection circuitry shall be implemented by hardware and independent from any on board software.

ECSS-E-ST-20_0020197

- i. Battery charge and discharge management shall be such that a single failure for unmanned missions and two failures for manned missions does not impair the lifetime of the energy storage system with respect to minimum or maximum voltage as well as maximum charge or maximum discharge current.

NOTE Such failure tolerance can be implemented at cell, battery or subsystem level.

5.7.4 Bus under-voltage or over-voltage

ECSS-E-ST-20_0020198

- a. For fuse protected busses the electrical subsystem shall be robust against any fuse blowing event occurring on the primary bus, even after one failure anywhere in the power subsystem.

NOTE 1 For voltage drop resulting from fuse blowing, robustness does not imply meeting performance parameters but means survival without overstressing of the system during this event and the recovery from it, so that proper operations can resume (autonomously or not) after the power bus transient, with nominal performance.

NOTE 2 Functional spacecraft outage is prevented by having all software and configuration data (e.g. RAM, registers) integrity guaranteed with 0V power bus voltage, on a duration twice the one of the voltage drop resulting from fuse blowing.

NOTE 3 See also requirement 5.8.1h.

ECSS-E-ST-20_0020199

- b. All non-essential loads shall be switched-off autonomously in the event of reaching the battery energy level that is able to maintain all essential loads for a time guaranteeing safe recovery.

ECSS-E-ST-20_0020200

- c. The ultimate non-essential load disconnection circuit shall be implemented as a full hard-wired chain from sensor to actuator.

NOTE Ultimate disconnection refers to the circuit being the last to disconnect the battery as a function of its state-of-charge.

ECSS-E-ST-20_0020201

- d. The ultimate non-essential load disconnection circuit shall be one failure tolerant if centralised.

ECSS-E-ST-20_0020202

- e. The spacecraft design shall be such that in the event of an under-voltage condition on the bus, no failure is induced in the power subsystem or the loads during and when recovering from this under-voltage.

ECSS-E-ST-20_0020203

- f. After recovery as mentioned in 5.7.4e the loads shall be as follows:
1. all essential loads be supplied nominally;

2. all non-essential loads be in a known configuration that cannot create damage to any part of the spacecraft.

5.7.5 Power converters and regulators

ECSS-E-ST-20_0020204

- a. For converters and regulators in closed loop control, the phase margin shall be at least 50° and the gain margin 6 dB for worst case end-of-life conditions with representative loading.

ECSS-E-ST-20_0020205

- b. For converters and regulators of the power subsystem, requirement 5.7.5a shall apply after any single failure.

NOTE Examples are solar array regulators, battery chargers and dischargers.

ECSS-E-ST-20_0020206

- c. The electrical zero-volt reference of isolated converters and regulators shall be isolated from the unit case by more than 10 k Ω per converter.

NOTE Rationale for this requirement:

The value of 10 k Ω is a compromise: to be very large in DC and low frequency to minimize ground loop currents and to be small for high frequencies above 5 MHz in order to minimize the volt-drop between references due to common mode currents.

ECSS-E-ST-20_0020207

- d. The capacitance between the zero-volt reference of isolated converters and regulators and the unit case shall be less than 150 nF per converter.

NOTE 1 Rationale for this requirement:

The value of 150 nF is a compromise such that for a given piece of equipment this value is sufficiently high to dominate all parasitic capacitances to unit case, and low enough such that if many equipment are connected to a bus, the sum of bypassing capacitors to unit case and thus to ground reference is not significantly biasing the insulation of the bus or bus return to ground.

NOTE 2 The measurement of the common mode capacitance is made with positive and return lines of the power switching converters shorted.

NOTE 3 The common mode capacitance accounts for both filtering and damping capacitors.

ECSS-E-ST-20_0020208

- e. If a switching converter is externally synchronized, it shall deliver output voltages within specification for any increase or decrease of synchronizing frequency, intermediate amplitude of synchronizing signal, phase jumps, or loss and recovery of the signal.

ECSS-E-ST-20_0020209

- f. An analysis at unit level shall be performed to verify that no single failure generates an increase of conducted emission exceeding specified limit by more than 6 dB.

ECSS-E-ST-20_0020210

- g. If an increase of conducted emission exceeding specified limit by more than 6 dB is identified from the unit level analysis of 5.7.5f, then a system level analysis shall be conducted to ensure that compatibility is maintained.

NOTE Rationale for this requirement:

6 dB is the margin usually taken between unit and subsystem when building up the EMC compatibility at system level. It means that failed equipment uses that EMC margin but does not perturb further the system.

ECSS-E-ST-20_0020211

- h. A switching converter shall be able to reach nominal operation when the nominal input voltage is applied with any slope that can be provided by the power source and its associated impedance, connected to the switching converter.

5.7.6 Payload interaction

ECSS-E-ST-20_0020212

- a. Inrush, under-voltage and a representative set of failures agreed with the customer for the payload interaction with the primary bus, shall be verified by test.

ECSS-E-ST-20_0020213

- b. No load shall generate a spurious response that can damage itself or any other equipment during bus voltage variation, up or down, at any ramp rate, and over the full range from zero to maximum bus voltage.

ECSS-E-ST-20_0020214

- c. All current limiting devices and automatic switch-off circuits shall be monitored by telemetry.

ECSS-E-ST-20_0020215

- d. The failure of the monitoring function of 5.7.6c shall not cause the protection elements to fail.

5.8 Power distribution and protection

5.8.1 General

ECSS-E-ST-20_0020216

- a. The primary power source shall be grounded to the spacecraft structure at the star reference point with a connection capable of sustaining the worst case fault current.

ECSS-E-ST-20_0020217

- b. <<deleted, replaced by requirements 5.8.1q to 5.8.1v>>

ECSS-E-ST-20_0020218

- c. <<deleted>>

ECSS-E-ST-20_0020219

- d. All load paths shall include protection circuitry on the source side.

NOTE The aim is to locate them as near as possible to the source.

ECSS-E-ST-20_0020220

- e. No load shall be permanently disconnected from its power source as a consequence of an SEE.

ECSS-E-ST-20_0020221

- f. If fuses are used to protect main bus distribution lines, provision shall be made allowing easy replacement of blown or defective fuse.

NOTE Provision can consist in easy accessibility to fuses or in replacement of concerned unit by available spare one.

ECSS-E-ST-20_0020222

- g. <<deleted>>

ECSS-E-ST-20_0020223

- h. If fuses are used to protect main bus distribution lines, the design shall ensure that the power generation system can fuse them within less than 45 ms in case of load short circuit.

ECSS-E-ST-20_0020224

- i. <<deleted>>

ECSS-E-ST-20_0020225

- j. Equipment connected to independent, redundant power buses not protected at the source shall ensure that:
1. for unmanned missions, no single failure causes the loss of more than one power bus;
 2. for manned missions, two failures do not cause the loss of more than one power bus.

ECSS-E-ST-20_0020226

- k. The stability of current limiters shall be ensured for the actual loads characteristics.

ECSS-E-ST-20_0020227

- l. <<deleted>>

ECSS-E-ST-20_0020228

- m. <<deleted>>

ECSS-E-ST-20_0020229

- n. In case the distribution lines are protected by latching, foldback or periodically reset current limiters, it shall be verified by analysis or test that the transient current peaks at current limiter intervention are within the rated stress limits of the components used, for the worst case condition (minimum series impedance case).

ECSS-E-ST-20_0020230

- o. When protection elements are in cascade, the closest one upstream from the anomaly should be the first to act.

ECSS-E-ST-20_0020231

- p. When protections are used in cascade from a power source to a function to be supplied, the compatibility of these protections shall be ensured.

ECSS-E-ST-20_0020412

- q. Whenever two or more blocks are connected in cascade, the stability of the cascade between each source block and load block shall be analysed with the source and load impedances characterised in compliance with Figure 5-2.

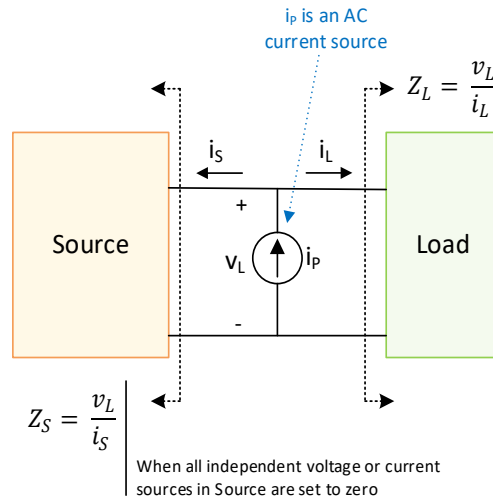

ECSS-E-ST-20_0020413

Figure 5-2: Source and load impedance characterisation

ECSS-E-ST-20_0020414

- r. Whenever two or more blocks are connected in cascade, the power source being conveniently modelled with a Thevenin equivalent in compliance with Figure 5-3 and equation 1 for the sake of interface voltage stability analysis, the following two conditions shall be met:
1. the difference between the phases of the source impedance and the load impedance is comprised in between $[-130^\circ, +130^\circ] \pm n \cdot 360^\circ$ at those frequencies in which the load and the source impedance are equal in magnitude,
 2. the ratio of the magnitudes of the source and the load impedance is smaller than a factor 0,5 at those frequencies in which the difference between the phase of the source impedance and the load impedance is equal to $-180^\circ \pm n \cdot 360^\circ$.

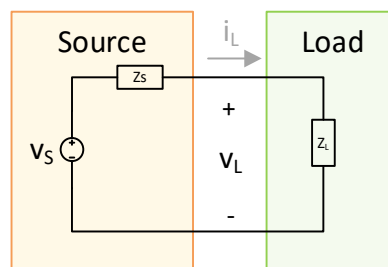

ECSS-E-ST-20_0020415

Figure 5-3: Thevenin equivalent model

$\frac{V_L}{V_S} = \frac{1}{1 + \frac{Z_S}{Z_L}}$	equation [1]
---	--------------

ECSS-E-ST-20_0020416

- s. In alternative to requirements 5.8.1q and 5.8.1r, assuming that a power source is modelled with a Thevenin equivalent, stability criterion given in Impedance Specifications for Stable DC Distributed Power Systems, EEE transactions on power electronics, Vol. 17, no. 2, March 2002 shall be applied.

ECSS-E-ST-20_0020417

- t. In alternative to, and under the same assumptions of requirement 5.8.1r, the magnitude of the source impedance shall be smaller than the magnitude of the load impedance by at least a factor 10.

ECSS-E-ST-20_0020418

- u. Whenever two or more blocks are connected in cascade, the power source being conveniently modelled with a Norton equivalent in compliance with Figure 5-4 and equation 2 for the sake of interface current stability analysis, the following two conditions shall be met:
1. the difference between the phases of the load impedance phase and the source impedance is comprised in between $[-130^\circ, +130^\circ] \pm n \cdot 360^\circ$ at those frequencies in which the load and the source impedance are equal in magnitude,
 2. the ratio between the magnitudes of the load and the source impedance is smaller than a factor 0,5 at those frequencies in which the difference between the load impedance phase and the source impedance phase is equal to $-180^\circ \pm n \cdot 360^\circ$.

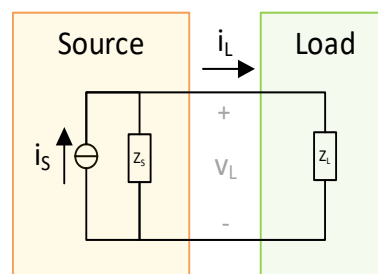

ECSS-E-ST-20_0020419

Figure 5-4: Norton equivalent model

$\frac{I_L}{I_s} = \frac{1}{1 + \frac{Z_L}{Z_S}}$	equation [2]
---	--------------

ECSS-E-ST-20_0020420

- v. In alternative to, and under the same assumptions of requirement 5.8.1u, the magnitude of the load impedance shall be smaller than the magnitude of the source impedance by at least a factor 10.

NOTE 1 The requirements 5.8.1r to 5.8.1v can be used as alternative by the user for verification purposes

(only one is used among 5.8.1r to 5.8.1t, or between 5.8.1u and 5.8.1v).

NOTE 2 The diagrams for the verification of requirements 5.8.1r to 5.8.1v are provided in Figure 5-2.

NOTE 3 The requirements 5.8.1r to 5.8.1v can be used for evaluating the small signal stability for systems that are linear or can be linearised around an operating point.

NOTE 4 n is a positive integer including 0.

ECSS-E-ST-20_0020421

- w. The stability of current limiters shall be verified by analysis under worst case conditions, and tested under a set of cases agreed with the customer.

ECSS-E-ST-20_0020422

- x. The requirement 5.8.1k shall be verified by worst case analysis, in accordance with ECSS-Q-ST-30 Annex J, and test.

5.8.2 Harness

ECSS-E-ST-20_0020232

- a. No piece of harness shall be used to transfer mechanical loads.

ECSS-E-ST-20_0020233

- b. With the exception of the solar array, routing of power lines shall be near ground.

ECSS-E-ST-20_0020234

- c. With the exception of the solar array and electrical bus bars, harness power lines shall be such that each line is twisted with its return, when the structure is not used as a return.

NOTE The purpose of the requirements b and c is to minimize current loop area and harness inductance.

ECSS-E-ST-20_0020235

- d. The power distribution shall be protected in such a way that no over-current in a distribution wire can propagate a thermal failure to another wire.

ECSS-E-ST-20_0020236

- e. The harness inductance for a fully regulated bus, from the distribution node of the regulated bus to the load, shall be such that the break frequency is at least 5 000 Hz.

NOTE 1 That means that:

$$L < R/2\pi f$$

where:

L harness inductance in H

R harness resistance in Ω

f_{break} frequency in Hz, i.e. $f = 5\,000$.

NOTE 2 Rationale for this requirement

This ties-up with the impedance mask requirement, because beyond the break frequency, the impedance is going to rise and one wants to keep the quality established on the regulation point with the impedance mask as best as possible and as far as possible to the loads.

ECSS-E-ST-20_0020237

- f. Harness shall be tested up to connector brackets under 500 V DC between conductors, conductors and structure, conductors and shielding.

NOTE 500 V DC is selected in order to detect insulation defects potentially induced by air voltage breakdown.

ECSS-E-ST-20_0020238

- g. The harness restraining systems on the structure shall not bring about any stress at connector level.

ECSS-E-ST-20_0020239

- h. There shall be umbilical and test connectors to provide external electrical interfaces.

NOTE 1 E.g. with the launcher and with the EGSE.

NOTE 2 Functions provided include all those necessary for supporting AIT and launch site activities (e.g. monitor spacecraft operation, maintain synchronization between spacecraft, EGSE and real time simulators, put the spacecraft in a defined operation scenario like a quick upload of SW).

ECSS-E-ST-20_0020240

- i. Electrical and Safe and arm plugs shall be provided for disabling on ground hazard functions.

NOTE For harness design and manufacturing guidelines and handbook, see RNC-CNES-Q-70-511 and NASA-STD-8739.4.

ECSS-E-ST-20_0020241

- j. If cross-strapping of redundant paths and circuits is carried out in the harness, then provisions of ECSS-E-ST-50-14 clause 4.2.5.2 shall apply.

5.9 Safety

ECSS-E-ST-20_0020242

- a. The design of electrical subsystems and payloads shall conform to ECSS-Q-ST-40.

5.10 High voltage engineering

ECSS-E-ST-20_0020243

- a. For non pressurised and non potted high voltage equipment, the applicable pressure range when this equipment is on shall be specified.

ECSS-E-ST-20_0020244

- b. Non pressurised and non potted high voltage equipment shall be designed and manufactured to avoid discharge phenomena according to Paschen curves valid for its specified pressure range.

NOTE ECSS-E-HB-20-05 provides useful directions on this aspect and in general to high voltage engineering.

ECSS-E-ST-20_0020245

- c. The field enhancement factors shall be ensured by the design.

NOTE This applies in particular to the routing of high voltage cables.

ECSS-E-ST-20_0020246

- d. For potted circuits, the glass transition point of the potting material shall be outside the temperature range of qualification.

ECSS-E-ST-20_0020247

- e. The design of high voltage equipment shall be such that worst case DC and AC field strengths are less than half of the values for which breakdown can occur.

5.11 Verification

5.11.1 Provisions

ECSS-E-ST-20_0020248

- a. The requirements of this Clause 5 should be verified by the verification methods and at the verification points listed in Table 8-3.

NOTE 1 Table 8-3 can be used as a starting point for the definition of the verification methods.

NOTE 2 For more details on verification, see also ECSS-E-ST-10-02, in particular requirements 5.2.1c, 5.2.1d and 5.2.1e.

5.11.2 <<deleted>>

- a. <<deleted>> ECSS-E-ST-20_0020249

- b. <<deleted>> ECSS-E-ST-20_0020250

- c. <<deleted>> ECSS-E-ST-20_0020251

- ECSS-E-ST-20_0020384

Table 5-3: <<deleted, merged with new Table 8-3>>

Electromagnetic compatibility (EMC)

6.1 Overview

The objective of the following EMC requirements is to ensure that the space system is designed to achieve electromagnetic compatibility (EMC) between all equipment and subsystems within the space system and in the presence of its self-induced and external electromagnetic environment.

6.2 Policy

6.2.1 Overall EMC programme

ECSS-E-ST-20_0020252

- a. The supplier shall establish an overall EMC programme.

NOTE 1 The EMC programme is an activity the purpose of which is to provide for spacecraft-level compatibility with the minimum impact to programme cost, schedule and operational capabilities. The role of the customer in the EMC programme is that of top-level oversight.

NOTE 2 The EMC programme is based on requirements of this standard, the statement of work, spacecraft specification, and other applicable contractual documents.

ECSS-E-ST-20_0020253

- b. The EMC programme shall:
1. plan and verify that EMC technical criteria, mainly design and management controls are in place to achieve EMC;
 2. plan and accomplish the verification of spacecraft-level EMC.

6.2.2 EMC control plan

ECSS-E-ST-20_0020254

- a. As part of the EMC programme, an EMC control plan shall be written by the supplier for the PDR in conformance with the DRD in Annex A.

NOTE The Control plan initial release documents the procedures of the EMC programme including basic design guidelines, while subsequent

routine updates document the programme progress.

ECSS-E-ST-20_0020255

- b. The EMC control plan shall apply to every item of equipment and subsystem in the project.

ECSS-E-ST-20_0020423

- c. An EMC control plan shall be produced for every subsystem and equipment in answer to the requirements applicable at its level.

6.2.3 Electromagnetic compatibility advisory board (EMCAB)

ECSS-E-ST-20_0020256

- a. For such programmes where EMC has been identified during phase A as critical for mission performance, the EMC programme shall include an EMC Advisory Board (EMCAB).

ECSS-E-ST-20_0020257

- b. The EMCAB shall:
 - 1. Ensure the timely and effective execution of the EMC programme under the general project manager.
 - 2. Respond to the problems related to EMC as they arise.

ECSS-E-ST-20_0020258

- c. The supplier shall chair the EMCAB, with customer oversight.
 - NOTE 1 The EMCAB members are representatives of the Spacecraft Supplier and payload suppliers and users.
 - NOTE 2 EMCAB members can invite associate suppliers or independent experts.
 - NOTE 3 The EMCAB accomplishes its duties and document its activities mainly through the use of the system-level EMC documentation.

6.3 System level

6.3.1 Electromagnetic interference safety margin (EMISM)

6.3.1.1 Circuits categories

ECSS-E-ST-20_0020259

- a. Functional criticality of circuits for all equipment/subsystem circuits shall be identified in accordance with the following categories:
 - 1. Safety critical circuit - EMI problems that can result in loss of life or loss of space platform. This category comprises electro-explosive devices and their circuits.
 - 2. Mission critical circuit - EMI problems that can result in injury, damage to space platform, mission abort or delay, or performance degradation which unacceptably reduces mission effectiveness.
 - 3. Non critical circuit – Any problems that do not belong to categories 6.3.1.1a.1 and 6.3.1.1a.2.

6.3.1.2 Critical points

ECSS-E-ST-20_0020260

- a. The list of points where the margin is demonstrated (critical points) shall be submitted to the customer for approval.

6.3.1.3 Margins

ECSS-E-ST-20_0020261

- a. Electromagnetic interference safety margins shall be determined at critical points under all operating conditions.

ECSS-E-ST-20_0020262

- b. The minimum margins shall be 20 dB for safety critical circuits, and 6 dB for mission critical circuits.

6.3.2 Inter-element EMC and EMC with environment

6.3.2.1 Overview

The objectives of the following requirements are to ensure that the space system operates without performance degradation in the electromagnetic environment due to external sources (natural sources and man-made sources, intentional or not).

6.3.2.2 EMC with the launch system

ECSS-E-ST-20_0020263

- a. The electromagnetic environment seen by the spacecraft and the EMC requirements during the pre-launch and launch phases shall be according to those described in the applicable launchers user's manuals.

NOTE Specific EMC requirements during the pre-launch and launch phase are described in an Interface Control document established on a contractual basis between the launching company and the customer.

6.3.2.3 Protected frequency bands

ECSS-E-ST-20_0020264

- a. For protection of radiometric and communication bands, requirements on "Emissions" of "Transmitted signals" in ECSS-E-ST-50-05 clause 5.5 shall apply.

6.3.2.4 Lightning

ECSS-E-ST-20_0020265

- a. The space system shall be protected against both direct and indirect effects of lightning such that the mission is without degradation of performances after exposure to the lightning environment.

6.3.3 Hazards of electromagnetic radiation

ECSS-E-ST-20_0020266

- a. The space system shall be designed so that humans, fuels, explosive systems, and electronically actuated thrusters are not exposed to hazards of electromagnetic radiation present in the entire electromagnetic environment, including interference sources from possible external transmitters.

6.3.4 Spacecraft charging protection program

6.3.4.1 Applicability

ECSS-E-ST-20_0020267

- a. A spacecraft charging protection programme shall be produced by the supplier for the PDR, and submitted to the customer for approval, in conformance with ECSS-E-ST-20-06 clause 5 and Annex A.

6.3.4.2 General

ECSS-E-ST-20_0020268

- a. The spacecraft charging protection programme shall include the preparation and maintenance of an analysis plan, and the preparation and maintenance of a test plan.

NOTE The objective of the programme is to ensure that the space vehicle is capable of operating in the specified space plasma charging environment and its energetic electron content without degradation of the specified space vehicle capability and reliability and without changes in operational modes, location, or orientation.

ECSS-E-ST-20_0020269

- b. The performance shall be accomplished without the intervention of external control such as commands from a ground station.

ECSS-E-ST-20_0020270

- c. The spacecraft charging protection programme shall include:
 1. surface electrostatic charging,
 2. threat from internal electrostatic charging of dielectric materials and isolated conducting items, due to the penetration of energetic electrons as defined in the environmental specification.

NOTE ECSS-E-ST-20-06 is intended to provide clear and consistent requirements to the application of measures to assess and mitigate hazardous effects arising from spacecraft charging and other environmental effects on a spacecraft's electrical behaviour.

6.3.4.3 Performance

ECSS-E-ST-20_0020403

- a. The space vehicle electrical subsystem and system may undergo an outage during an arc discharge if operation and performance returns to specified levels within

1. a telemetry main frame period after onset of the discharge, or
2. within some other period defined by the customer.

ECSS-E-ST-20_0020404

- b. <<deleted>>

ECSS-E-ST-20_0020273

- c. Occurrence of an arc discharge during transmission of a command to the space vehicle from an external source as a ground station shall not result in any unintended action, whether the command is executed or not.

NOTE An external source can be a ground station.

ECSS-E-ST-20_0020274

- d. Provision shall be made such that the space vehicle is capable of receiving and executing subsequent commands.

ECSS-E-ST-20_0020275

- e. Provision shall be made such that the space vehicle meets specified performances within the time period defined in clause 6.3.4.3a.

6.3.5 Intrasytem EMC

ECSS-E-ST-20_0020276

- a. The space system shall operate without performance degradation in the electromagnetic environment due to on-board sources, intentional or not.

6.3.6 Radio frequency compatibility

ECSS-E-ST-20_0020277

- a. The spacecraft shall be RF compatible with all antenna-connected equipments and subsystems, the compatibility criteria being based on the mission performance and operability requirements.

ECSS-E-ST-20_0020278

- b. When an inter-system interface is required, each system shall be RF compatible with all antenna-connected equipments and subsystems, the compatibility criteria being based on the mission performance and operability requirements.

ECSS-E-ST-20_0020279

- c. The RF compatibility analysis, if used instead of test, shall include the effects of inter-modulation products.

6.3.7 Spacecraft DC magnetic field emission

6.3.7.1 Overview

DC magnetic emissions have impacts on two main areas, magnetic sensors of payloads and the attitude control system (ACS). Other specific components are susceptible (ultra-stable crystal oscillators, plasma monitors, high-permeability magnetic shields).

6.3.7.2 Spacecraft with susceptible payload

ECSS-E-ST-20_0020280

- a. In case the payload involves equipments sensitive to DC H-Field, the maximum acceptable DC magnetic field at their location from the rest of the spacecraft shall be specified by the customer because of the mission performance requirements.

NOTE It is the role of the EMCAB to translate the customer's DC magnetic field requirements, specified at the sensitive payload location, into subsystem and equipment magnetic requirements (magnetic field or magnetic moment limits, test methods).

6.3.7.3 Attitude control subsystem

ECSS-E-ST-20_0020281

- a. On the basis of the attitude control requirements, the supplier shall derive magnetic requirements for the spacecraft so as to limit transient, diurnal and secular torques.

ECSS-E-ST-20_0020282

- b. If magnetometers are used as part of the Spacecraft Attitude Control Subsystem, the maximum acceptable DC magnetic field at their location from the rest of the spacecraft shall be specified by the supplier because of the attitude control subsystem requirements and submitted to the customer approval.

6.3.8 Design provisions for EMC control

6.3.8.1 Electrical bonding

ECSS-E-ST-20_0020283

- a. The electrical bonding shall be in conformance with the requirements specified in clauses 4.2.11 and 5.3.10 of ECSS-E-ST-20-07.

6.3.8.2 Grounding

ECSS-E-ST-20_0020284

- a. A controlled ground reference concept, including the definition of circuit and unit categories shall be specified and agreed with the customer for the spacecraft prior to initial release of the EMC control plan.

6.3.8.3 Wiring

ECSS-E-ST-20_0020285

- a. Classification of cables, and cables shield shall be in conformance with the requirements specified in clauses 4.2.13 and 5.3.11 of ECSS-E-ST-20-07.

6.3.9 Detailed design requirements

ECSS-E-ST-20_0020286

- a. The EMC system design shall be performed in conformance with the requirements specified in clause 4.2 of ECSS-E-ST-20-07.

6.4 Verification

6.4.1 Verification plan and report

ECSS-E-ST-20_0020287

- a. The verification plan shall be accomplished by the supplier in the frame of the EMC programme.

ECSS-E-ST-20_0020288

- b. The verification plan shall be documented in the electromagnetic effects verification plan (EMEVP) in conformance with the DRDs in Annex B.

ECSS-E-ST-20_0020289

- c. An electromagnetic effects verification report (EMEVr) in conformance with the DRD in Annex C shall be prepared by the supplier.

6.4.2 Safety margin demonstration for critical or EED circuit

ECSS-E-ST-20_0020290

- a. Safety margins for critical or EED circuit shall be demonstrated at system-level.

ECSS-E-ST-20_0020291

- b. If the demonstration of safety margins is done by test, the spacecraft suite of equipment and subsystems shall be operated in a manner simulating actual operations, agreed with the customer.

6.4.3 Detailed verification requirements

ECSS-E-ST-20_0020292

- a. EMC verification shall be performed in conformance with the requirements on “Verification” in specified in ECSS-E-ST-20-07.

Radio frequency systems

7.1 Functional description

Radio frequency (RF) systems include transmitters, receivers, antennas and their associated transmission lines (waveguides) including connectors, operating typically in the range from 30 MHz to 300 GHz. The transmitted or received signals can be narrowband or wideband, often with complex modulation and sometimes with multiple carriers. Transmitters and receivers require high mutual insulation and antennas can interact strongly with the spacecraft.

For achieving the RF performance requirements, the following parameters are considered by the engineering process:

- antenna field of view and polarization;
- link or radiometric budget;
- spatial and spectral resolution;
- signal to noise ratio;
- frequency plan.

For achieving the performances requirement, the following parameters are considered by the RF design and development:

- transmitter power;
- receiver sensitivity;
- active and passive intermodulation products;
- multipaction;
- corona;
- spectral purity;
- VSWR;
- frequency stability;
- reflection and diffraction effects on antenna performance;
- mutual coupling between antennas;
- insulation between transmitter and receiver;
- EIRP.

7.2 Antennas

7.2.1 General

7.2.1.1 Overview

As specified in ECSS-E-ST-10, budgets and margins are established and requested during Project phase B, and reviewed in all subsequent phases of the project.

7.2.1.2 Provisions

7.2.1.2.1 Definition of terms in the documentation

ECSS-E-ST-20_0020293

- a. All antenna terms used in all documentation (DDF, DJF, Test Report, Test Procedures, ICD and EIDP) shall follow the definitions found in IEEE 145:1993 "Antenna Terms".

7.2.1.2.2 Engineering process

ECSS-E-ST-20_0020294

- a. The following engineering process shall be applied:
 1. Perform an analysis of the mission requirements for RF signal transmission and reception for all systems and payload for all phases of the mission.
 2. Perform electrical, mechanical and thermal computer assessments to identify feasibility and performance margin for the whole antenna farm
 3. Establish performance budgets, including losses, simulation/measurement error and technology maturity margins for the whole antenna farm.
 4. Establish prediction, measurement and operational error/accuracy budgets for the whole antenna farm.
 5. Establish a plan for the maintenance and periodical review of the budgets established in requirement 7.2.1.2.2a.3 and 7.2.1.2.2a.4 during all project phases.

NOTE to item 4: E.g. Pointing, excitation, phase centre.

7.2.1.3 Failure containment and redundancy

ECSS-E-ST-20_0020295

- a. Antennas are in general single point failure elements; therefore their failure rates shall be agreed with the customer, specified and demonstrated.

NOTE To improve the failure rate, special precautions in the redundancy architecture are commonly taken to cover the failures of active elements.

7.2.2 Antenna structure

7.2.2.1 General

ECSS-E-ST-20_0020296

- a. The antenna category (7.2.2.2), composing elements (7.2.2.2.4), used technologies (7.2.2.4) and the performance parameters (7.2.2.5) shall be established at the beginning of the project phase B.

7.2.2.2 Categories

7.2.2.2.1 TT&C and data transmission

ECSS-E-ST-20_0020297

- a. The antenna radiation pattern shall be characterised including the scattering effects of all surrounding structures.

NOTE TT&C and data transmission antennas are in general compact antennas (individual radiating elements - 7.2.2.3.1) with broad radiation patterns and a single beam. In some cases (e.g. deep space missions), more complex antennas falling into one of the other categories are used.

ECSS-E-ST-20_0020298

- b. If a number of TT&C antennas operate simultaneously, the combined radiation pattern shall be used in the performance evaluation.

7.2.2.2.2 Reflector/Lens antennas

ECSS-E-ST-20_0020299

- a. The reflection and transmission properties (losses, depolarisation and diffusivity) of the reflecting or transmitting elements shall be quantified and their impact on antenna performances assessed.

NOTE Reflector/Lens antennas are constituted by one or more radiating elements (7.2.2.3.1), possibly including an antenna RF chain (7.2.2.3.5), one or more (partially) reflecting or transmitting elements (reflectors - 7.2.2.3.2, lenses - 7.2.2.3.3) and an antenna support structure (in one or more portions- 7.2.2.3.6). If several radiating elements are present, also a Beam Forming Network can be present to distribute the RF signal (7.2.2.3.4).

ECSS-E-ST-20_0020300

- b. The effects of antenna support structures shall be quantified and the impact on antenna performances assessed.

ECSS-E-ST-20_0020301

- c. Deformations of reflector antennas, which parts are physically attached to different portions of the spacecraft platform, shall be quantified and their impact on antenna performance assessed.

NOTE For large reflector antennas that use hold-down and release, deployment mechanisms as well as pointing devices, ECSS-E-ST-33-11 can be applied.

7.2.2.2.3 Array antennas

ECSS-E-ST-20_0020302

- a. The effect of the radiation of individual array element on the others shall be quantified and the impact on antenna performances assessed.

NOTE Array antennas are constituted by a number of radiating elements (7.2.2.3.1), possibly including an antenna RF chain (7.2.2.3.5) and arranged in a more or less regular layout. The RF signals are routed to/from each element through a wave-guiding network generally known as Beam Forming Network (7.2.2.3.4). An antenna support structure can also be present 7.2.2.3.6.

ECSS-E-ST-20_0020303

- b. The effects of antenna support structures on the main RF wave propagation path shall be quantified and the impact on performance assessed.

ECSS-E-ST-20_0020304

- c. Deformations of array antennas, which parts are physically attached to different portions of the spacecraft platform, shall be quantified and their impact on antenna performance assessed.

NOTE For large array antennas that use hold-down and release, deployment mechanisms as well as pointing devices, ECSS-E-ST-33-11 can be applied.

7.2.2.2.4 Array-fed reflector antennas

ECSS-E-ST-20_0020305

- a. For array-fed reflector antennas clauses 7.2.2.2.2 (Reflector/Lens antennas) and 7.2.2.2.3 (Array antennas) shall apply.

7.2.2.3 Elements

7.2.2.3.1 Radiating elements

ECSS-E-ST-20_0020306

- a. The isolated performances of radiating elements shall be characterised as part of the performance prediction of the whole antenna, at least up to the end of Phase B.

NOTE Individual radiating elements are a key element to the overall antenna performances. They can be completed by a chain of RF components (see antenna RF chain 7.2.2.3.5), to ensure a suitable RF interface.

ECSS-E-ST-20_0020307

- b. Whenever an antenna RF chain is attached to the radiating element its impact on the radiating element performances shall be assessed.

ECSS-E-ST-20_0020308

- c. Deviations from the nominal geometry of the radiating element shall be quantified and their impact on antenna performances assessed.

NOTE Typical deviations are due to manufacturing errors, thermo-elastic effects and modification of the material characteristic in the orbit environment, moisture release in composites.

ECSS-E-ST-20_0020309

- d. It shall be demonstrated that the scattering of the radiation pattern of individual radiating elements does not affect the accuracy of all radiated performance measurement.

ECSS-E-ST-20_0020310

- e. Thermal dissipation of RF power shall be quantified and the impact on antenna performances assessed.

ECSS-E-ST-20_0020311

- f. Whenever a radiating element is used to route high power levels,
1. The applicable pressure range and gas properties shall be specified.
 2. The design and manufacturing shall be performed to avoid discharge phenomena according to Paschen curves valid for its specified pressure range and gas properties.

NOTE See clause 7.3 for further details.

ECSS-E-ST-20_0020312

- g. All metallic parts in a radiating element shall be connected to the equipment DC ground to avoid electrostatic discharge (ESD).

7.2.2.3.2 RF Reflectors

ECSS-E-ST-20_0020313

- a. Reflective properties (losses, depolarisation, and diffusivity) of the materials and composites used shall be quantified and their impact on antenna performances assessed.

ECSS-E-ST-20_0020314

- b. The reflective and transmissive properties (losses, depolarisation, diffusivity) of the materials and composites used for polarisation and frequency selective reflectors shall be quantified and their impact on antenna performances assessed.

ECSS-E-ST-20_0020315

- c. Deviations from the nominal geometry of the reflector shall be quantified and their impact on antenna performances assessed.

NOTE 1 Reflectors can require hold-down and release, deployment as well as pointing devices. ECSS-E-ST-33-11 and ECSS-Q-ST-70 are relevant and applicable in this case.

NOTE 2 Typical deviations are due to manufacturing errors, thermo-elastic effects and modification of the material characteristic in the orbit environment, moisture release in composites.

7.2.2.3.3 RF Lenses

ECSS-E-ST-20_0020316

- a. Reflective and transmissive properties of the materials and composites used for the lenses shall be quantified and their impact on antenna performances assessed.

NOTE Examples of reflective and transmissive properties are losses, depolarization and diffusivity.

ECSS-E-ST-20_0020317

- b. Deviations from the nominal geometry of the lens shall be quantified and their impact on antenna performances assessed.

NOTE Typical deviations are due to manufacturing errors, thermo-elastic effects and modification of the material characteristic in the orbit environment, moisture release in composites.

ECSS-E-ST-20_0020318

- c. Measures to drain accumulated electric charges from all non conductive parts shall be implemented to avoid electrostatic discharge (ESD).

ECSS-E-ST-20_0020319

- d. Any metallic parts shall be connected to the equipment DC ground to avoid electrostatic discharge (ESD).

7.2.2.3.4 RF Beam Forming Network

ECSS-E-ST-20_0020320

- a. The circuit characteristics of the RF BFN shall be independently quantified and their impact on antenna performances assessed at least up to CDR.

ECSS-E-ST-20_0020321

- b. Deviations from the nominal geometry of the RF BFN shall be quantified and their impact on antenna performances assessed.

NOTE Typical deviations are due to manufacturing errors, thermo-elastic effects and modification of the material characteristic in the orbit environment, moisture release in composites.

ECSS-E-ST-20_0020322

- c. In all RF BFN structures having a central conductor (ideally insulated), the thermal power generated by Joule effect on the conductor itself shall be quantified and its impact on antenna performances assessed.

ECSS-E-ST-20_0020323

- d. For RF BFN, the applicable pressure range and gas properties shall be specified.

ECSS-E-ST-20_0020324

- e. For RF BFN, the design and manufacturing shall be performed to avoid discharge phenomena according to Paschen curves valid for its specified pressure range and gas properties.

NOTE See clause 7.3 for further details.

7.2.2.3.5 Antenna RF chain

ECSS-E-ST-20_0020325

- a. The circuit characteristics of the antenna RF chain shall be independently quantified and their impact on antenna performances assessed at least up to CDR.

ECSS-E-ST-20_0020326

- b. The cumulative effects of wave propagation discontinuities along the whole antenna RF chain, including the radiating elements attached to it, shall be quantified and the impact on antenna performances assessed.

ECSS-E-ST-20_0020327

- c. For antenna RF chain the applicable pressure range and gas properties shall be specified.

ECSS-E-ST-20_0020328

- d. For antenna RF chain the design and manufacturing shall be performed to avoid discharge phenomena according to Paschen curves valid for its specified pressure range and gas properties.

NOTE See clause 7.3 for further details.

7.2.2.3.6 Antenna support structures

ECSS-E-ST-20_0020329

- a. The possible scattering effects of the support structures shall be quantified and their impact on the antenna performances assessed.

ECSS-E-ST-20_0020330

- b. Deviations from the nominal geometry of the supporting structure shall be quantified and their impact on antenna performances assessed.

NOTE Typical deviations are due to manufacturing errors, thermo-elastic effects and modification of the material characteristic in the orbit environment, moisture release in composites.

7.2.2.4 Technologies

7.2.2.4.1 Metal based

ECSS-E-ST-20_0020331

- a. The level of passive inter-modulation products generated by the antenna shall be quantified and their impact on antenna performances assessed.

NOTE 1 See clause 7.4 for further details.

NOTE 2 Ferro-magnetic materials and metal-to-metal junctions are the most common non-linear elements in antennas.

ECSS-E-ST-20_0020332

- b. The impact of thermally-induced effects on the generation of passive intermodulation products shall be quantified and the impact on antenna performances assessed.

NOTE A typical example of thermally induced effects triggering the generation of PIM is the sudden releases of stresses in metal-to-metal joints due to temperature variations.

ECSS-E-ST-20_0020333

- c. Thermally induced changes of dimension and shape in all metallic antenna parts shall be quantified and their impact on antenna performances assessed.

7.2.2.4.2 Composite based

ECSS-E-ST-20_0020334

- a. The impact of surface characteristics and finish on antenna performances shall be assessed.

NOTE 1 In particular this is essential for the RF conductive surfaces of the component.

NOTE 2 Electrical conductivity and depolarisation properties are the most typical parameters affected.

ECSS-E-ST-20_0020335

- b. Thermally induced changes of dimension and shape in all composite and combined metal-composite antenna parts shall be quantified and their impact on antenna performances assessed.

ECSS-E-ST-20_0020336

- c. Measures to drain accumulated electric charges from composite parts shall be implemented to avoid electrostatic discharge (ESD).

7.2.2.4.3 Plastic based

ECSS-E-ST-20_0020337

- a. The dielectric losses of plastic component in the RF power path shall be quantified and their impact on antenna performances assessed.

NOTE Components made from homogeneous plastic are usually limited to small parts (e.g. spacers or washers).

ECSS-E-ST-20_0020338

- b. Thermally induced changes of dimension and shape in all plastic and combined metal-plastic antenna parts shall be quantified and their impact on antenna performances assessed.

ECSS-E-ST-20_0020339

- c. Measures to drain accumulated electric charges from all plastic parts shall be implemented to avoid electrostatic discharge (ESD).

7.2.2.5 Performance parameters

ECSS-E-ST-20_0020340

- a. The characterisation of antenna performances shall cover the following parameters.
1. Coverage or Beam shape;
 2. Directivity;
 3. Electrical boresight or Beam pointing;
 4. Gain or Beam efficiency;
 5. Input impedance mismatch factor;
 6. Radiation pattern;
 7. Sense of polarization;
 8. Side lobe level;
 9. Polarisation purity or Axial ratio;
 10. Group delay;
 11. Noise temperature, for receive antennas;
 12. Phase centre position;
 13. Variations with frequency, angle (where applicable) and aging of all above parameters.

7.2.3 Antenna interfaces

7.2.3.1 Guided-wave interfaces

ECSS-E-ST-20_0020341

- a. Connectors or waveguide flanges at the antenna ports shall be demonstrated to have the specified power handling capabilities and impedance mismatch factors.

NOTE Antenna RF ports are realised using a wave-guiding structure (coaxial cable or waveguide, in most instances). Connectors or flanges are used to realise the physical interface.

ECSS-E-ST-20_0020342

- b. It shall be demonstrated that the generation of passive inter-modulation products that can occur at the antenna ports is below the specified limits agreed with the customer.

ECSS-E-ST-20_0020343

- c. For antenna ports the applicable pressure range and gas properties shall be specified.

ECSS-E-ST-20_0020344

- d. For antenna ports the design and manufacturing shall be performed to avoid discharge phenomena according to Paschen curves valid for its specified pressure range and gas properties.

NOTE See clauses 7.3 and 7.4 for further details.

7.2.3.2 Radiative interfaces

ECSS-E-ST-20_0020345

- a. Electromagnetic interactions among the antenna and the surrounding spacecraft structure and appendages shall be quantified starting from Phase B, as a minimum, and their impact on antenna performances assessed.

NOTE The field radiated or received by the antenna interacts with the surrounding environment. Interactions with the spacecraft structure and appendages usually have a direct impact on the antenna performances.

ECSS-E-ST-20_0020346

- b. For all high-power applications, the risk of generation of passive inter-modulation products by the surrounding spacecraft structure and appendages shall be assessed starting from Phase B, as a minimum, and the impact on antenna performances assessed.

7.2.4 Antennas Verification

ECSS-E-ST-20_0020347

- a. The requirements of this clause 7.2 shall be verified by the verification methods, at the reviews, and recorded in the documents as specified in Table 8-3.

NOTE For verification, see also ECSS-E-ST-10-02.

ECSS-E-ST-20_0020385

Table 7-1: <<deleted, merged with new Table 8-3>>

7.3 RF Power

7.3.1 Overview

The objective of the following RF breakdown requirements is to ensure that the space system operates at maximum power levels without any risk of Multipaction, RF power handling limitation and Corona (also called “gas discharge”).

- Multipaction requirements are described in ECSS-E-ST-20-01.
- RF power handling requirements are described in clause 7.3.2.
- Corona (or Gas Discharge) requirements are described in clause 7.3.3 and apply for:
 - vented RF components during launch and pressurisation due to out-gassing of the spacecraft or re-entry, and
 - pressurized RF components.

7.3.2 RF Power handling (thermal)

7.3.2.1 General requirements

ECSS-E-ST-20_0020348

- a. All the components and equipments of the RF chain shall be able to stand the maximum specified operating RF power during its application in space with:
 1. no degradation of the component,
 2. no degradation of the RF signal including radiative losses, and
 3. with their thermal levels not exceeding those corresponding to the maximum available RF power at the maximum qualification temperature.

7.3.2.2 Design and Verification

ECSS-E-ST-20_0020349

- a. Each element of the RF chain shall be designed and verified to withstand the maximum specified operating RF power levels plus safety margins agreed with the customer in the development phase at the maximum qualification temperature.

7.3.3 Corona or Gas Discharge

7.3.3.1 General requirements

ECSS-E-ST-20_0020350

- a. All the components and equipments of the RF chain shall be free of any risk of Gas discharge (Corona) at the maximum specified operating RF power over the full pressure range during:
1. the depressurization of the RF components and equipments at launch environmental conditions,
 2. the pressurization due to out-gassing of the spacecraft in orbit,
 3. ground testing at ambient pressure, and
 4. the pressurization of the spacecraft during planetary re-entry phases at the mission environmental conditions.

ECSS-E-ST-20_0020351

- b. For those components and equipments which design does not allow operating them over the full pressure range the following action shall be taken:
1. specify the applicable pressure range and gas properties,
 2. ensure that the design and manufacturing is such to avoid discharge phenomena according to Paschen curves valid for its specified pressure range and gas properties.

7.3.3.2 Design and Verification

ECSS-E-ST-20_0020352

- a. RF components and equipments of the RF chain shall be designed and verified to withstand the maximum specified operating RF power levels plus safety margins agreed with the customer in the development phase.

7.3.4 Qualification for power handling and gas discharge

ECSS-E-ST-20_0020353

- a. The following criteria shall be met for qualification for power handling and gas discharge:
1. the RF component and equipment has no physical degradation,
 2. the RF component and equipment has no degradation of the RF performance during and after the test.

7.4 Passive intermodulation

7.4.1 Overview

Passive intermodulation products are generated when two or more RF transmit signals illuminate or passing through a non-linear passive RF component. The RF frequencies of the passive intermodulation products are derived as for any other generation of intermodulation products, when two or more RF signals are present simultaneously. However, the power levels of the passive intermodulation products depend on the materials used, manufacturing tolerances and processes, assemble techniques, and oxidation of surfaces. Thus, they are hardly predictable implying that verification by test is mandatory for those intermodulation products that can adversely impact the mission or cause interference in third party protected frequency bands.

7.4.2 General requirements

ECSS-E-ST-20_0020354

- a. The acceptance level of interference caused by passive intermodulation products shall be agreed with the customer in the development phase.

ECSS-E-ST-20_0020355

- b. All the components of the RF chain shall be designed and manufactured to guarantee that the passive intermodulation products derived from the transmit carriers do not cause interference with any of the spacecraft receive bands or third party protected frequency bands during the operating temperature cycles.

7.4.3 Identification of potentially critical intermodulation products

ECSS-E-ST-20_0020356

- a. All operating conditions shall be identified in which two or more transmit RF signals simultaneously illuminate or passed through a passive RF component, equipment or both.

ECSS-E-ST-20_0020357

- b. For each of the conditions identified in 7.4.3a, the frequencies, number of carriers and power levels of these carriers shall be determined.

ECSS-E-ST-20_0020358

- c. An analysis shall be performed to establish all the passive intermodulation products falling within any of the spacecraft receive bands or third party protected frequency bands, for all combinations of frequency carriers up to the intermodulation order of 100.

7.4.4 Verification

ECSS-E-ST-20_0020359

- a. Testing at the lowest intermodulation order as identified in 7.4.3c shall be performed to ensure that the amplitudes of the passive intermodulation products are below the specified interference level.

ECSS-E-ST-20_0020360

- b. Passive Intermodulation tests shall be carried out on the flight hardware in the same configuration as it is during operational use.

ECSS-E-ST-20_0020361

- c. The test frequencies, number of carriers and power levels of these carriers shall be those as identified in 7.4.3b.

ECSS-E-ST-20_0020362

- d. Qualification testing shall be carried out
 1. on RF non radiative passive components, or equipments, or systems, over the full qualification temperature range,
 2. on RF radiative components, equipments or systems over a temperature range to be agreed with the customer, range which can be limited to ambient temperature.

ECSS-E-ST-20_0020363

- e. Acceptance testing shall be carried out on flight components, equipments or systems over an acceptance temperature range to be agreed with the customer, range which can be limited to ambient temperature.

7.4.5 Qualification for passive intermodulation

ECSS-E-ST-20_0020364

- a. The amplitude of each passive intermodulation product falling within any of the spacecraft receive bands or third party protected frequency bands shall be lower than the level specified in 7.4.2a.

7.5 Verification

ECSS-E-ST-20_0020405

- a. The requirements of the clauses 7.3 and 7.4 should be verified by the verification methods, at the reviews, and recorded in the documentation as specified in Table 8-3.

ECSS-E-ST-20_0020406

Table 7-2: <<deleted, merged with new Table 8-3>>

8

Pre-tailoring matrix per space product and feature types

8.1 Introduction

The pre-tailoring matrix of this ECSS Standard is defined in Table 8-3 and is given as a guidance to support tailoring.

It identifies “Inclusive requirements” per space product type and “Exclusive requirements” per features.

Inclusive requirements are applicable to one or several of the following product types:

- a. SSE: Space Segment Element (physical view of Space Segment System)
- b. SSS: Space Segment Sub-system
- c. SSEq: Space Segment Equipment
- d. LSE: Launch Segment Elements (physical view of Launch Segment System)
- e. LSS: Launch Segment Subsystem
- f. LSEq: Launch Segment Equipment
- g. GSE: Ground Segment Elements (physical view of Ground Segment System)
- h. GSS: Ground Segment Subsystems
- i. GSEq: Ground Segment Equipment
- j. Electrical Ground Support Equipment

For the definition of the space product types, refer to ECSS-S-ST-00-01.

NOTE “Ground Support Equipment” is a separate product type not to be confused with “Ground segment equipment”.

“Exclusive requirements” are valid to the specific following subsystem, equipment, function, characteristic or component, referred to as “features” in the present context:

- a. Electrical Power Subsystem
- b. Power Conditioning Unit
- c. Power distribution and protection
- d. Solar Array
- e. Solar Array Drive Mechanism/Electronics
- f. Battery
- g. Battery management
- h. Redundant

- i. Switching converter
- j. Generates/Receives telecommand
- k. High Voltage
- l. Single shot device
- m. Circuit for single shot device
- n. Antenna and RF chain

Exclusive requirements refer to requirements that are exclusively applicable for the identified feature(s).

8.2 Use of the inclusive and exclusive requirement categories

The way to use the inclusive and exclusive categories is the following:

- a. Identify which space product type requirements are applicable to a given case by using the relevant column of the inclusive requirements set. For example, SSEq (third column of space product types).
- b. If SSEq is for example not a PCU, neither a PDU nor a Solar Array, it is possible to derive the requirements valid for the given case by removing from the column SSEq (inclusive requirements) those exclusively applicable to PCU, PDU and Solar Array, since these are valid for those equipment only.

Another example is given below:

- a. If the unit is a PCU, but it does not contain single shot devices, then use the column SSEq (inclusive requirements) and remove from that the requirements valid for relay, Hybrid or SSDs in the relevant columns.

In summary, a given requirement can be ignored on the condition that the features identified as exclusive for that requirement are altogether not relevant to the scope of the concerned space product(s).

The different statuses of requirement applicability used in the pre-tailoring matrix are defined in Table 8-1.

NOTE A requirement is considered as applicable to a given space product type if it is verified on this product type.

In Table 8-3 verification points, methods and records are also provided.

Finally, it is important to understand that the present pre-tailoring is made assuming typically applicable architectures.

For example, the following hypotheses are made:

- a. Launchers have no solar arrays
- b. Spacecraft encompasses satellites, landers, rovers and probes
- c. Space vehicles encompass spacecraft and launchers
- d. Solar Arrays are considered as equipment part of the Electrical Power Subsystem

New architectures and new technologies can request an update of the ECSS-E-ST-20 and its pre-tailoring matrix.

For the requirements of clause 7, the following remarks are for consideration when using the re-tailoring matrix:

- a. The accommodation of the different antennas on the spacecraft being the duty of the spacecraft provider, some requirements, for example the one related to scattering effect, are managed at spacecraft level even if few characterization test are required at equipment supplier level (e.g. antenna supplier level). The final performance of antenna at satellite level being also the duty of the spacecraft supplier.
- b. The spacecraft often accommodate several antennas and it is then also the duty of the spacecraft supplier to manage their compatibility even if some characterisation tests are performed by the antenna providers.
- c. On board of spacecraft and on ground, an antenna is generally directive and composed of a reflector and one or several feeds. The antenna provider can procure the reflector and feeds from different suppliers.
- d. In most of the case, feeds and reflectors are acceptance tested separately. Base on all those considerations, it's considered here that
 1. the level of "equipment" is devoted to feeds and reflector and more generally to the components of an antenna. They are acceptance tested at stand-alone including RF characterization (feeds), shape and surface characterization (reflectors). Stand-alone acceptance include generally complete or partial environmental testing.
 2. the level of subsystem is devoted to the provision of one whole antenna (e.g. active antenna array, gregorian antenna assembly, antenna composed of reflector and feeds assembled at satellite level). An antenna is therefore considered as a subsystem that is different to the assumption of the ECSS Glossary (ECSS-S-ST-00-01) Annex B.1.

Table 8-1: Definition of pre-tailoring matrix applicability statuses

Applicability status	Description
X	Requirement applicable
-	Requirement not applicable
//	Requirement applicability pre-tailoring not definable (applicability to be determined during tailoring)
>>	Requirement applicability pending tailoring to be achieved at lower product type
E	Requirement exclusively concerned by the identified feature(s)

Table 8-2: Definition of features for exclusive requirements

#	Feature	Comment
1	Electrical Power Subsystem	Applicable to any segment
2	Power Conditioning Unit	Relevant to primary power conditioning
3	Power distribution and protection	Typically relevant (but not limited) to primary Power Distribution Unit
4	Solar Array	
5	Solar Array Drive Mechanism/Electronics	Relevant to Solar Array Drive Mechanism or Electronics
6	Battery	
7	Battery management	
8	Redundant	Relevant to redundancy implemented at equipment level or at higher level
9	Switching converter	Relevant to power conversion by switching (including S3R)
10	Generates/Receives telecommand	Generates or Receives telecommand
11	High Voltage	High Voltage assessed with respect to Corona effect (250 V threshold for Earth atmosphere)
12	Single shot device	E.g. pyro devices or Non Explosive Actuators
13	Circuit for single shot device	E.g. pyro driver
14	Antenna and RF chain	

ECSS Source Id	Req. Statement	ECSS Object Type	Verification			Inclusive requirements									Exclusive requirements														
			Verification Points (SRR, PDR, etc, see complete list at the end of this table)	Verification Methods (RoD, A, etc see complete list at the end of this table)	Recorded in [1] Electrical ICD (incl. SAR, Battery Antenna) [2] Budget document (e.g. Power, Energy, Processor, and memory budgets) [3] DDF or DJF [4] GDIR [5] Tests Report [6] Specification [7] User Manual [8] EIDP	SSE: Space Segment Element (physical view of Space Segment System)	SSS: Space segment sub-system	SSEq: Space Segment Equipment	LSE: Launch Segment Elements (physical view of Launch Segment System)	LSS: Launch Segment Subsystem	LSEq: Launch Segment Equipment	GSE: Ground Segment Elements (physical view of Ground Segment System)	GSS: Ground Segment Subsystems	GSEq: Ground Segment Equipment	Electrical Ground Support Equipment	Electrical Power Subsystem	Power Conditioning Unit	Power distribution and protection	Solar Array	Solar Array Drive Mechanism/Electronics	Battery	Battery management	Redundant	Switching converter	Generates/Receives telecommand	High Voltage	Single shot device	Circuit for single shot device	Antenna an RF chain
4.1.3i	Any on-board processing which issues commands to reconfigure subsystems or payloads shall be overridable and potentially inhibited by ground command.	Requirement	PDR, CDR	RoD, T	-	X	//	//	-	-	-	X	//	//	-	-	-	-	-	-	-	-	-	-	E	-	-	-	-
4.1.3j	No valid command shall be issued until the transmitter power supply is within operational voltage range and ready to transmit the command.	Requirement	PDR, CDR	RoD, A, T	-	X	//	//	X	//	//	X	//	//	X	-	-	-	-	-	-	-	-	-	E	-	-	-	-
4.1.4a	Telemetry data devoted to the spacecraft subsystem and payloads monitoring shall allow 1 the retracing of the overall configuration at least up to all reconfigurable elements. 2 the location of any failure able to impact the mission performances and reliability at least up to all reconfigurable elements.	Requirement	PDR, CDR	RoD, A	-	X	//	//	X	//	//	-	-	-	-	-	-	-	-	-	-	-	-	-	-	-	-	-	-
4.1.4b	The operational status (On/Off, enabled/disabled, active/not-active) of each element of any telemetry acquisition chain should be provided to the on-board computer in order to determine without ambiguity the validity of the telemetry data at the end of the overall chain.	Recommendation	PDR	RoD, A, T	-	X	//	//	X	//	//	-	-	-	-	-	-	-	-	-	-	-	-	-	-	-	-	-	-
4.1.4c	Primary bus load currents shall be monitored by telemetry, to enable, together with the bus voltage telemetry, a complete monitoring of a primary bus power load.	Requirement	PDR	RoD, A, T	-	X	//	//	X	//	//	-	-	-	-	-	-	-	-	-	-	-	-	-	-	-	-	-	-
4.1.4d	Telemetry shall be implemented to monitor the evolution of the power-energy resources and the source temperatures during the mission.	Requirement	PDR, CDR	RoD, A	-	X	//	//	X	//	//	-	-	-	-	-	-	-	-	-	-	-	-	-	-	-	-	-	-

ECSS Source Id	Req. Statement	ECSS Object Type	Verification			Inclusive requirements								Exclusive requirements															
			Verification Points (SRR, PDR, etc, see complete list at the end of this table)	Verification Methods (RoD, A, etc see complete list at the end of this table)	Recorded in [1] Electrical ICD (incl. SAR, Battery Antenna) [2] Budget document (e.g. Power, Energy, Processor, and memory budgets) [3] DDF or DJF [4] GDIR [5] Tests Report [6] Specification [7] User Manual [8] EIDP	SSE: Space Segment Element (physical view of Space Segment System)	SSS: Space segment sub-system	SSEq: Space Segment Equipment	LSE: Launch Segment Elements (physical view of Launch Segment System)	LSS: Launch Segment Subsystem	LSEq: Launch Segment Equipment	GSE: Ground Segment Elements (physical view of Ground Segment System)	GSS: Ground Segment Subsystems	GSEq: Ground Segment Equipment	Electrical Ground Support Equipment	Electrical Power Subsystem	Power Conditioning Unit	Power distribution and protection	Solar Array	Solar Array Drive Mechanism/Electronics	Battery	Battery management	Redundant	Switching converter	Generates/Receives telecommand	High Voltage	Single shot device	Circuit for single shot device	Antenna an RF chain
4.2.1.1a	Failure propagation shall meet the following conditions: 1 A single hardware failure does not propagate to neighbouring components circuits or interfaces in an undetermined way. 2 Failure propagation is verified by analysis. 3 Mechanical, thermal or electrical propagation of single hardware failures does not impair the corresponding protection or redundancy implemented at equipment or system level. 4Single hardware failure does not propagate to equipment or functions under different contractual responsibility than the item where the failure takes place.	Requirement	PDR	A	-	X	X	X	X	X	X	-	-	-	//	-	-	-	-	-	-	-	-	-	-	-	-	-	-
4.2.1.1b	Redundant signal or power lines should be segregated via physically separated connectors and harnesses.	Requirement	PDR, CDR	RoD	-	//	//	//	//	//	//	-	-	-	//	-	-	-	-	-	-	-	E	-	-	-	-	-	-
4.2.1.1c	Routing of redundant power or signal lines within common harness or connector shall be justified by analysis showing that inside the electrical unit and at external connector interface level there is no potential single failure leading to affect both nominal and redundant lines or to generate electrical or electromagnetic interference between both.	Requirement	PDR, CDR	A	-	//	//	//	//	//	//	-	-	-	//	-	-	-	-	-	-	-	E	-	-	-	-	-	-
4.2.1.1d	Redundant functions shall be physically separated with no risk of failure propagation by thermal or other coupling and as a minimum, contained within different integrated circuits to avoid failure propagation.	Requirement	PDR	RoD, A	-	//	//	//	//	//	//	-	-	-	-	-	-	-	-	-	-	-	E	-	-	-	-	-	-
4.2.1.1e	For redundant functions implemented on the same PCB, a physical separation shall be provided, with no risk of thermal or other failure propagation.	Requirement	PDR	RoD, A	-	-	-	//	-	-	//	-	-	-	-	-	-	-	-	-	-	-	E	-	-	-	-	-	-

ECSS Source Id	Req. Statement	ECSS Object Type	Verification			Inclusive requirements									Exclusive requirements													
			Verification Points (SRR, PDR, etc, see complete list at the end of this table)	Verification Methods (RoD, A, etc see complete list at the end of this table)	Recorded in [1] Electrical ICD (incl. SAR, Battery Antenna) [2] Budget document (e.g. Power, Energy, Processor, and memory budgets) [3] DDF or DJF [4] GDIR [5] Tests Report [6] Specification [7] User Manual [8] EIDP	SSE: Space Segment Element (physical view of Space Segment System)	SSS: Space segment sub-system	SSEq: Space Segment Equipment	LSE: Launch Segment Elements (physical view of Launch Segment System)	LSS: Launch Segment Subsystem	LSEq: Launch Segment Equipment	GSE: Ground Segment Elements (physical view of Ground Segment System)	GSS: Ground Segment Subsystems	GSEq: Ground Segment Equipment	Electrical Ground Support Equipment	Electrical Power Subsystem	Power Conditioning Unit	Power distribution and protection	Solar Array	Solar Array Drive Mechanism/Electronics	Battery	Battery management	Redundant	Switching converter	Generates/Receives telecommand	High Voltage	Single shot device	Circuit for single shot device
4.2.1.1f	For redundant functions implemented on the same PCB, any deviation of the physical separation specified in 4.2.1.1e shall be tracked in the Critical item List.	Requirement	PDR	RoD, A	-	-	-	//	-	-	//	-	-	-	-	-	-	-	-	-	-	E	-	-	-	-	-	-
4.2.1.1g	<<deleted>>	-	-	-	-	-	-	-	-	-	-	-	-	-	-	-	-	-	-	-	-	-	-	-	-	-	-	
4.2.1.1h	In case a cold redundant function is simultaneously activated together with the nominal one, by a deliberate or wrong command or due to a fault, this shall not induce permanent degradation of either of the two functions or loss of the mission before FDIR action.	Requirement	PDR	RoD, A	-	//	//	//	//	//	//	-	-	-	-	-	-	-	-	-	E	-	-	-	-	-	-	
4.2.1.1i	<<deleted>>	-	-	-	-	-	-	-	-	-	-	-	-	-	-	-	-	-	-	-	-	-	-	-	-	-	-	
4.2.1.1j	Any active equipment, excluding heaters, continuously dissipating more than 20 W in nominal or failure condition shall include a temperature monitoring function, which is implemented and provides continuous temperature monitoring.	Requirement	PDR	RoD, A	-	-	-	X	-	-	//	-	-	-	-	-	-	-	-	-	-	-	-	-	-	-	-	
4.2.1.1k	In case of signal cross-strapping, no single failure of either interface circuit shall propagate to the other one.	Requirement	PDR	RoD, A	-	X	X	X	X	X	X	-	-	-	-	-	-	-	-	-	-	-	-	-	-	-	-	
4.2.1.1l	In the case of hot redundant essential functions, latching protection shall not be used unless it has an autonomous periodic reset.	Requirement	PDR	RoD	-	X	//	//	//	//	//	-	-	-	-	-	-	-	-	-	-	-	-	-	-	-	-	
4.2.1.1m	Disabling critical on-board autonomous functions shall be allowed only if an interlock mechanism is implemented, which prevents the disabling of both main and redundant functions at the same time.	Requirement	PDR	RoD, A, T	-	X	//	//	//	//	//	-	-	-	-	-	-	-	-	-	-	-	-	-	-	-	-	
4.2.1.1n	Any protection latch, which does not have autonomous reset capability, shall be at least re-settable from ground command.	Requirement	PDR	RoD, A, T	-	X	X	X	X	X	X	-	-	-	-	-	-	-	-	-	-	-	-	-	-	-	-	
4.2.1.1o	Any protection of an essential function shall not share with the essential function itself the same component or integrated circuit nor utilize common references or auxiliary supply.	Requirement	PDR	RoD	-	-	-	//	-	-	//	-	-	-	-	-	-	-	-	-	-	-	-	-	-	-	-	

ECSS Source Id	Req. Statement	ECSS Object Type	Verification			Inclusive requirements										Exclusive requirements																				
			Verification Points (SRR, PDR, etc, see complete list at the end of this table)	Verification Methods (RoD, A, etc see complete list at the end of this table)	Recorded in [1] Electrical ICD (incl. SAR, Battery Antenna) [2] Budget document (e.g. Power, Energy, Processor, and memory budgets) [3] DDF or DJF [4] GDIR [5] Tests Report [6] Specification [7] User Manual [8] EIDP	SSE: Space Segment Element (physical view of Space Segment System)	SSS: Space segment sub-system	SSEQ: Space Segment Equipment	LSE: Launch Segment Elements (physical view of Launch Segment System)	LSS: Launch Segment Subsystem	LSEq: Launch Segment Equipment	GSE: Ground Segment Elements (physical view of Ground Segment System)	GSS: Ground Segment Subsystems	GSEq: Ground Segment Equipment	Electrical Ground Support Equipment	Electrical Power Subsystem	Power Conditioning Unit	Power distribution and protection	Solar Array	Solar Array Drive Mechanism/Electronics	Battery	Battery management	Redundant	Switching converter	Generates/Receives telecommand	High Voltage	Single shot device	Circuit for single shot device	Antenna an RF chain							
4.2.1.2.3x	Critical lines and nets shall be identified as part of a FMECA process or of a dedicated analysis at the beginning of the system, subsystem or equipment development, at relevant PDR at the latest.	Requirement	PDR	ROD	[1], [3]	X	//	//	X	//	//	-	-	-	//	-	-	-	-	-	-	-	-	-	-	-	-	-	-	-	-	-	-	-	-	
4.2.1.2.3y	A dedicated analysis shall confirm that reliable insulation of critical lines or nets is not jeopardized by failures, at system, subsystem or equipment level.	Requirement	PDR, CDR	A	[3]	X	//	//	X	//	//	-	-	-	//	-	-	-	-	-	-	-	-	-	-	-	-	-	-	-	-	-	-	-	-	
4.2.1.2.3z	Critical lines or nets shall be clearly identifiable in electrical diagrams and in layout and assembly drawings.	Requirement	PDR, CDR	RoD	[3], [8]	X	//	//	X	//	//	-	-	-	//	-	-	-	-	-	-	-	-	-	-	-	-	-	-	-	-	-	-	-	-	
4.2.1.2.3aa	The electrical diagrams, layout and assembly drawings providing the information of the critical lines or nets may be part of the relevant analysis report.	Permission	PDR, CDR	ROD	[3]	X	//	//	X	//	//	-	-	-	//	-	-	-	-	-	-	-	-	-	-	-	-	-	-	-	-	-	-	-	-	
4.2.1.2.3bb	Compliance to Reliable insulation requirements of critical lines or nets shall be verified by review of design as well as by inspection and/or by test if possible.	Requirement	PDR, CDR, DRB, AR	ROD, INS, T	[3], [5], [8]	X	//	//	X	//	//	-	-	-	//	-	-	-	-	-	-	-	-	-	-	-	-	-	-	-	-	-	-	-	-	
4.2.1.2.3cc	Verification of reliable insulation requirements should take place any time when it might be jeopardised by integration or rework activities, exposure to specific environment, electrical connection or disconnection.	Recommendation	TRB, DRB, AR	INS, T	[3], [8]	X	//	//	X	//	//	-	-	-	//	-	-	-	-	-	-	-	-	-	-	-	-	-	-	-	-	-	-	-	-	
4.2.2.2a	For technical budgets and margin policy the requirements of ECSS-E-ST-10 clause 5.4.1.2 shall be applied.	Requirement	SRR	RoD	-	X	X	X	//	//	//	-	-	-	-	-	-	-	-	-	-	-	-	-	-	-	-	-	-	-	-	-	-	-	-	-
4.2.2.2b	The margin for available memory size and load factors of processors should be 1 for new developments, 50 % as a minimum at PDR for new on board software parts; 2 25 % at launch.	Recommendation	PDR	RoD, A	-	-	-	X	-	-	//	-	-	-	-	-	-	-	-	-	-	-	-	-	-	-	-	-	-	-	-	-	-	-	-	-
4.2.2.2c	The margin on the throughput of on-board communication networks should be 1 for new developments, 50 % as a minimum at PDR on the average throughput; 2 such that real time overflow is avoided.	Recommendation	PDR	RoD, A	-	X	X	X	//	//	//	-	-	-	-	-	-	-	-	-	-	-	-	-	-	-	-	-	-	-	-	-	-	-	-	-

ECSS Source Id	Req. Statement	ECSS Object Type	Verification			Inclusive requirements										Exclusive requirements												
			Verification Points (SRR, PDR, etc, see complete list at the end of this table)	Verification Methods (RoD, A, etc see complete list at the end of this table)	Recorded in [1] Electrical ICD (incl. SAR, Battery Antenna) [2] Budget document (e.g. Power, Energy, Processor, and memory budgets) [3] DDF or DJF [4] GDIR [5] Tests Report [6] Specification [7] User Manual [8] EIDP	SSE: Space Segment Element (physical view of Space Segment System)	SSS: Space segment sub-system	SSEQ: Space Segment Equipment	LSE: Launch Segment Elements (physical view of Launch Segment System)	LSS: Launch Segment Subsystem	LSEq: Launch Segment Equipment	GSE: Ground Segment Elements (physical view of Ground Segment System)	GSS: Ground Segment Subsystems	GSEQ: Ground Segment Equipment	Electrical Ground Support Equipment	Electrical Power Subsystem	Power Conditioning Unit	Power distribution and protection	Solar Array	Solar Array Drive Mechanism/Electronics	Battery	Battery management	Redundant	Switching converter	Generates/Receives telecommand	High Voltage	Single shot device	Circuit for single shot device
4.2.3g	For supplies and signals of pyrotechnics and non-explosive single shot device drivers, different connectors should be used for different classes of electrical functions.	Recommendation	PDR	RoD	-	X	X	X	X	X	X	-	-	-	X	-	-	-	-	-	-	-	-	-	-	-	E	-
4.2.3h	When 4.2.3g is not met, power, signals, and telemetry shall be separated in the connector by a set of unused pin locations.	Requirement	PDR	RoD	-	X	X	X	X	X	X	-	-	-	X	-	-	-	-	-	-	-	-	-	-	-	E	-
4.2.3i	Except when pin allocation is imposed by a standard specification, spare contacts or sockets should be available on each connector.	Requirement	PDR	RoD	-	X	X	X	//	//	//	-	-	-	-	-	-	-	-	-	-	-	-	-	-	-	-	-
4.2.3j	For new developments, when the connection is not aligned to a defined standard, 10% spare contacts at unit PDR and at least 5 % at CDR shall be achieved with in any case a minimum of two spare contacts available at CDR.	Requirement	PDR	RoD	-	X	X	X	X	X	X	-	-	-	-	-	-	-	-	-	-	-	-	-	-	-	-	-
4.2.3k	In the absence of grounding provision at connector shell level, at least one contact per connector shall be connected to the unit structure as provision for potential additional grounding at subsystem or system level.	Requirement	PDR	RoD	-	X	X	X	//	//	//	-	-	-	-	-	-	-	-	-	-	-	-	-	-	-	-	-
4.2.3l	Provision shall be taken to avoid arcing or short circuits in connectors.	Requirement	PDR	RoD, A	-	X	X	X	//	//	//	-	-	-	-	-	-	-	-	-	-	-	-	-	-	-	-	-
4.2.3m	The following shall be performed for any connector the loss of which can lead to the loss of the mission: 1 Document the connector in the single point failure list 2 Verify and document its integrity up to the highest spacecraft integration level, to avoid accidental demating	Requirement	PDR	RoD, INS	-	X	X	X	//	//	//	-	-	-	-	-	-	-	-	-	-	-	-	-	-	-	-	-
4.2.3n	<<deleted>>	-	-	-	-	-	-	-	-	-	-	-	-	-	-	-	-	-	-	-	-	-	-	-	-	-	-	-
4.2.3o	Battery and solar array power shall be distributed by multiple contacts on both positive and return lines.	Requirement	PDR	RoD	-	X	X	X	//	//	//	-	-	-	-	-	-	-	-	-	-	-	-	-	-	-	-	-
4.2.4a	Test-stimulus points shall be accessible without the need of modifying the electrical configuration of an item of equipment.	Requirement	PDR	RoD, INS	-	X	X	X	X	X	X	-	-	-	-	-	-	-	-	-	-	-	-	-	-	-	-	-
4.2.4b	Test-stimulus points shall be protected for flight operation.	Requirement	PDR	RoD, INS	-	X	X	X	//	//	//	-	-	-	-	-	-	-	-	-	-	-	-	-	-	-	-	-
4.2.4c	For the purpose of meeting requirement 4.2.4a and 4.2.4b, dedicated test connectors should be used.	Recommendation	PDR	RoD	-	X	X	X	//	//	//	-	-	-	-	-	-	-	-	-	-	-	-	-	-	-	-	-

ECSS Source Id	Reqt. Statement	ECSS Object Type	Verification			Inclusive requirements									Exclusive requirements															
			Verification Points (SRR, PDR, etc, see complete list at the end of this table)	Verification Methods (RoD, A, etc see complete list at the end of this table)	Recorded in [1] Electrical ICD (incl. SAR, Battery Antenna) [2] Budget document (e.g. Power, Energy, Processor, and memory budgets) [3] DDF or DJF [4] GDIR [5] Tests Report [6] Specification [7] User Manual [8] EIDP	SSE: Space Segment Element (physical view of Space Segment System)	SSS: Space segment sub-system	SSEq: Space Segment Equipment	LSE: Launch Segment Elements (physical view of Launch Segment System)	LSS: Launch Segment Subsystem	LSEq: Launch Segment Equipment	GSE: Ground Segment Elements (physical view of Ground Segment System)	GSS: Ground Segment Subsystems	GSEq: Ground Segment Equipment	Electrical Ground Support Equipment	Electrical Power Subsystem	Power Conditioning Unit	Power distribution and protection	Solar Array	Solar Array Drive Mechanism/Electronics	Battery	Battery management	Redundant	Switching converter	Generates/Receives telecommand	High Voltage	Single shot device	Circuit for single shot device	Antenna an RF chain	
5.3a	Any protection function of a power converter or regulator preventing failure propagation shall: 1 not be implemented in the same integrated circuit, and 2 not utilize common references.	Requirement	PDR	RoD	[3]	-	-	X	-	-	X	-	-	-	-	-	-	-	-	-	-	-	-	-	-	-	-	-	-	-
5.3b	It shall not be possible to inhibit a protection feature if such an inhibition can lead to the loss of the main primary power bus in case of a single failure at spacecraft level.	Requirement	PDR	RoD, A	[3]	X	X	X	X	X	X	-	-	-	-	-	-	-	-	-	-	-	-	-	-	-	-	-	-	
5.3c	In flight operation, if primary power bus shutdown happens, the system, including the power subsystem, shall be able to restart.	Requirement	PDR	RoD, A	[3]	X	X	//	-	-	-	-	-	-	-	-	-	-	-	-	-	-	-	-	-	-	-	-		
5.3d	<<deleted>>	-	-	-	-	-	-	-	-	-	-	-	-	-	-	-	-	-	-	-	-	-	-	-	-	-	-	-	-	
5.4a	The electrical power interface internal or external to the power subsystem shall be specified, including source and load impedance.	Requirement	SRR	RoD	[1][4][6]	X	X	X	X	X	X	-	-	-	-	-	-	-	-	-	-	-	-	-	-	-	-	-	-	
5.4b	<<deleted>>	-	-	-	-	-	-	-	-	-	-	-	-	-	-	-	-	-	-	-	-	-	-	-	-	-	-	-	-	

ECSS Source Id	Req. Statement	ECSS Object Type	Verification			Inclusive requirements								Exclusive requirements																			
			Verification Points (SRR, PDR, etc, see complete list at the end of this table)	Verification Methods (RoD, A, etc see complete list at the end of this table)	Recorded in [1] Electrical ICD (incl. SAR, Battery Antenna) [2] Budget document (e.g. Power, Energy, Processor, and memory budgets) [3] DDF or DJF [4] GDIR [5] Tests Report [6] Specification [7] User Manual [8] EIDP	SSE: Space Segment Element (physical view of Space Segment System)	SSS: Space segment sub-system	SSEq: Space Segment Equipment	LSE: Launch Segment Elements (physical view of Launch Segment System)	LSS: Launch Segment Subsystem	LSEq: Launch Segment Equipment	GSE: Ground Segment Elements (physical view of Ground Segment System)	GSS: Ground Segment Subsystems	GSEq: Ground Segment Equipment	Electrical Ground Support Equipment	Electrical Power Subsystem	Power Conditioning Unit	Power distribution and protection	Solar Array	Solar Array Drive Mechanism/Electronics	Battery	Battery management	Redundant	Switching converter	Generates/Receives telecommand	High Voltage	Single shot device	Circuit for single shot device	Antenna an RF chain				
5.4c	The availability of the specified solar array power up to the power conditioning electronics shall be verified as follows: 1on solar array level, availability of the specified solar array power up to and including the solar array connector by means of flasher tests, supported by correlated analysis, 2on spacecraft level, full steady-state solar array power conditioning capability from solar array connector to power conditioning electronics, including solar array drive mechanism if any and harness, using solar array simulator, 3and finally, on spacecraft level, correct electrical connection of the solar array to the power conditioning unit by means of a flood test, that is by illumination of the solar array with a portable continuous lamp, checking if the generated voltage and current are detected at power conditioning side.	Requirement	AR	A, T	[3][5]	X	//	//	-	-	-	-	-	-	-	-	-	E	-	-	-	-	-	-	-	-	-	-	-	-	-	-	-
5.4d	The solar array interface voltage shall be defined at the solar array connector interface.	Requirement	PDR	RoD	[1][4][6]	-	//	//	-	-	-	-	-	-	-	-	-	E	-	-	-	-	-	-	-	-	-	-	-	-	-	-	
5.4e	The solar array interface voltage shall include voltage losses within the electrical circuitry of the solar array, including at least blocking diodes, wiring resistance and losses associated with harness interconnections in operational conditions.	Requirement	PDR	A	[3]	X	//	//	-	-	-	-	-	-	-	-	-	E	-	-	-	-	-	-	-	-	-	-	-	-	-	-	
5.5.2a	The solar array shall be specified to provide the requested power and ensure the energy balance in each mission phase during operational life including any string loss tolerance defined by the customer, spacecraft charging effects and worst case conditions.	Requirement	PDR	A	[2]	-	//	-	-	-	-	-	-	-	E	-	-	-	-	-	-	-	-	-	-	-	-	-	-	-	-	-	
5.5.2b	<<deleted>>	-	-	-	-	-	-	-	-	-	-	-	-	-	-	-	-	-	-	-	-	-	-	-	-	-	-	-	-	-	-	-	
5.5.2c	<<deleted>>	-	-	-	-	-	-	-	-	-	-	-	-	-	-	-	-	-	-	-	-	-	-	-	-	-	-	-	-	-	-	-	-

ECSS Source Id	Req. Statement	ECSS Object Type	Verification			Inclusive requirements								Exclusive requirements																			
			Verification Points (SRR, PDR, etc, see complete list at the end of this table)	Verification Methods (RoD, A, etc see complete list at the end of this table)	Recorded in [1] Electrical ICD (incl. SAR, Battery Antenna) [2] Budget document (e.g. Power, Energy, Processor, and memory budgets) [3] DDF or DJF [4] GDIR [5] Tests Report [6] Specification [7] User Manual [8] EIDP	SSE: Space Segment Element (physical view of Space Segment System)	SSS: Space segment sub-system	SSEq: Space Segment Equipment	LSE: Launch Segment Elements (physical view of Launch Segment System)	LSS: Launch Segment Subsystem	LSEq: Launch Segment Equipment	GSE: Ground Segment Elements (physical view of Ground Segment System)	GSS: Ground Segment Subsystems	GSEq: Ground Segment Equipment	Electrical Ground Support Equipment	Electrical Power Subsystem	Power Conditioning Unit	Power distribution and protection	Solar Array	Solar Array Drive Mechanism/Electronics	Battery	Battery management	Redundant	Switching converter	Generates/Receives telecommand	High Voltage	Single shot device	Circuit for single shot device	Antenna an RF chain				
5.5.2d	Provision shall be made against potential failure propagation in case of short-circuit failure of a solar array section or short circuit of its connection to the power subsystem.	Requirement	PDR	RoD, A	[3]	>>	//	//	-	-	-	-	-	-	E	-	-	-	-	-	-	-	-	-	-	-	-	-	-	-	-	-	-
5.5.2e	The solar array design shall be such that charging phenomena do not degrade the performance of the solar array below the ones specified in 5.5.2a and meeting the requirements specified in clauses 5.5.1.5 of ECSS-E-ST-20-08.	Requirement	PDR	RoD, A	[3]	>>	>>	//	-	-	-	-	-	-	-	-	-	E	-	-	-	-	-	-	-	-	-	-	-	-	-	-	-
5.5.2f	The following requirements and omissions for ESD shall apply: 1. ESD testing is performed. 2. ESD testing is performed in line with ECSS-E-ST-20-06 and ECSS-E-ST-20-08 demonstrating minimum safety margins as specified in clauses 5.5.1.5 of ECSS-E-ST-20-08. 3. ESD testing of solar arrays can be omitted for solar arrays with voltage less than or equal to 10 V, independent of current and gap distance. 4. For voltages below 30 V ESD testing can be omitted as well, provided the current remains below 0,6 A and gap width above 0,9 mm.	Requirement	Qualificati on review	T	[5], [8]	>>	>>	//	-	-	-	-	-	-	-	-	-	E	-	-	-	-	-	-	-	-	-	-	-	-	-	-	-

ECSS Source Id	Req. Statement	ECSS Object Type	Verification			Inclusive requirements										Exclusive requirements													
			Verification Points (SRR, PDR, etc, see complete list at the end of this table)	Verification Methods (RoD, A, etc see complete list at the end of this table)	Recorded in [1] Electrical ICD (incl. SAR, Battery Antenna) [2] Budget document (e.g. Power, Energy, Processor, and memory budgets) [3] DDF or DJF [4] GDIR [5] Tests Report [6] Specification [7] User Manual [8] EIDP	SSE: Space Segment Element (physical view of Space Segment System)	SSS: Space segment sub-system	SSEq: Space Segment Equipment	LSE: Launch Segment Elements (physical view of Launch Segment System)	LSS: Launch Segment Subsystem	LSEq: Launch Segment Equipment	GSE: Ground Segment Elements (physical view of Ground Segment System)	GSS: Ground Segment Subsystems	GSEq: Ground Segment Equipment	Electrical Ground Support Equipment	Electrical Power Subsystem	Power Conditioning Unit	Power distribution and protection	Solar Array	Solar Array Drive Mechanism/Electronics	Battery	Battery management	Redundant	Switching converter	Generates/Receives telecommand	High Voltage	Single shot device	Circuit for single shot device	Antenna an RF chain
5.5.2g	In all configurations, stowed and deployed, the solar array , deployable and body mounted, and spacecraft structure shall be insulated from each other, disregarding the bleed resistor.	Requirement	PDR, CDR, TRB, DRB, AR	RoD, T	[3][5]	>>	//	//	-	-	-	-	-	-	-	-	-	E	-	-	-	-	-	-	-	-	-	-	-
5.5.2h	In the flight configuration, means to prevent differential voltage due to electrostatic charging between solar array structure and the spacecraft electrical ground reference shall be implemented.	Requirement	PDR	RoD, A, T	[3][5]	>>	//	//	-	-	-	-	-	-	-	-	-	E	-	-	-	-	-	-	-	-	-	-	-
5.5.2i	In the flight configuration, bleeding resistors shall be implemented.	Requirement	PDR	RoD, A, T	[3][5]	>>	>>	//	-	-	-	-	-	-	-	-	-	E	-	-	-	-	-	-	-	-	-	-	-
5.5.2j	At solar array level, one short between a solar cell string and a conductive panel structure shall not produce any solar array power loss.	Requirement	PDR	RoD, A	[3]	>>	//	//	-	-	-	-	-	-	-	-	-	E	-	-	-	-	-	-	-	-	-	-	-
5.5.2k	At solar array level, in case of two shorts on the same panel, the power loss shall not be more than the power of two strings.	Requirement	PDR	RoD, A	[3]	>>	>>	//	-	-	-	-	-	-	-	-	-	E	-	-	-	-	-	-	-	-	-	-	-
5.5.2l	The PVA layout shall be designed to meet the solar array magnetic moment requirements.	Requirement	PDR	RoD, A	[3]	>>	>>	//	-	-	-	-	-	-	-	-	-	E	-	-	-	-	-	-	-	-	-	-	-
5.5.2m	<<deleted>>	-	-	-	-	-	-	-	-	-	-	-	-	-	-	-	-	-	-	-	-	-	-	-	-	-	-	-	-
5.5.2n	<<deleted>>	-	-	-	-	-	-	-	-	-	-	-	-	-	-	-	-	-	-	-	-	-	-	-	-	-	-	-	-
5.5.2o	Provision shall be made to prevent failure due to operation in shadow.	Requirement	PDR	RoD, A	[3]	>>	>>	//	-	-	-	-	-	-	-	-	-	E	-	-	-	-	-	-	-	-	-	-	-
5.5.2p	Solar array shall be designed in sections according to the redundancy principle specified at system level.	Requirement	PDR	RoD	[3]	>>	>>	//	-	-	-	-	-	-	-	-	-	E	-	-	-	-	-	-	-	-	-	-	-

ECSS Source Id	Req. Statement	ECSS Object Type	Verification			Inclusive requirements										Exclusive requirements																					
			Verification Points (SRR, PDR, etc, see complete list at the end of this table)	Verification Methods (RoD, A, etc see complete list at the end of this table)	Recorded in [1] Electrical ICD (incl. SAR, Battery Antenna) [2] Budget document (e.g. Power, Energy, Processor, and memory budgets) [3] DDF or DJF [4] GDIR [5] Tests Report [6] Specification [7] User Manual [8] EIDP	SSE: Space Segment Element (physical view of Space Segment System)	SSS: Space segment sub-system	SSEq: Space Segment Equipment	LSE: Launch Segment Elements (physical view of Launch Segment System)	LSS: Launch Segment Subsystem	LSEq: Launch Segment Equipment	GSE: Ground Segment Elements (physical view of Ground Segment System)	GSS: Ground Segment Subsystems	GSEq: Ground Segment Equipment	Electrical Ground Support Equipment	Electrical Power Subsystem	Power Conditioning Unit	Power distribution and protection	Solar Array	Solar Array Drive Mechanism/Electronics	Battery	Battery management	Redundant	Switching converter	Generates/Receives telecommand	High Voltage	Single shot device	Circuit for single shot device	Antenna an RF chain								
5.5.2q	Solar cells shall be protected against any deleterious reverse-bias conditions.	Requirement	PDR	RoD, A, T	[3][5]	>>	>>	//	-	-	-	-	-	-	-	-	-	E	-	-	-	-	-	-	-	-	-	-	-	-	-	-	-	-	-		
5.5.2r	The conductive panels substrates shall be electrically insulated from each other and from the other structural parts of the solar array.	Requirement	PDR, CDR, TRB, DRB, AR	RoD, T	[6], [3], [8]	>>	>>	//	-	-	-	-	-	-	-	-	-	E	-	-	-	-	-	-	-	-	-	-	-	-	-	-	-	-	-		
5.5.2s	For the purpose of insulation in solar arrays the following shall not be considered as a valid insulating layer: 1. Silicone based adhesives 2. Conformal coatings	Requirement	PDR, CDR	RoD	[3], [8]	>>	>>	//	>>	>>	//	-	-	-	-	-	-	-	-	-	-	-	-	-	-	-	-	-	-	-	-	-	-	-	-	-	
5.5.2t	Insulation of solar array wires shall be provided with two different layers of materials or use of 2 individually cured layer of materials.	Requirement	PDR, CDR	RoD	[1], [3]	>>	>>	//	-	-	-	-	-	-	-	-	-	E	-	-	-	-	-	-	-	-	-	-	-	-	-	-	-	-	-	-	
5.5.2u	All individual electrical elements of the solar array shall be reliably insulated with respect to the ground of the spacecraft.	Requirement	PDR, CDR	RoD, A	[3]	>>	>>	//	-	-	-	-	-	-	-	-	-	E	-	-	-	-	-	-	-	-	-	-	-	-	-	-	-	-	-	-	
5.5.3a	Computation of solar array power shall be based on measurements at cell level performed in accordance with the requirements of clause 10 of ECSS-E-ST-20-08.	Requirement	PDR	INS	[6]	>>	>>	//	-	-	-	-	-	-	-	-	-	E	-	-	-	-	-	-	-	-	-	-	-	-	-	-	-	-	-	-	
5.5.3b	The model used for the computation of the I(V) curve of the solar cell shall be validated by test on the specific solar cell type for the mission in conditions representative of the expected domain of operation.	Requirement	PDR	A, T	[3][5]	>>	>>	//	-	-	-	-	-	-	-	-	-	E	-	-	-	-	-	-	-	-	-	-	-	-	-	-	-	-	-	-	-
5.5.3c	I(V) solar cells characteristics shall be computed in BOL and EOL conditions at maximum and minimum operating temperatures according to the mission profile.	Requirement	PDR	A	[2][3]	>>	>>	//	-	-	-	-	-	-	-	-	-	E	-	-	-	-	-	-	-	-	-	-	-	-	-	-	-	-	-	-	-
5.5.3d	The EOL solar cell I(V) curve shall be derived from measurements performed at the temperatures specified in 5.5.3c after irradiation with particles in conformance with the "Electron irradiation" and "Proton irradiation" tests for "Bare solar cells" specified in ECSS-E-ST-20-08 clause 7, and agreed with the customer.	Requirement	CDR	T	[5]	>>	>>	//	-	-	-	-	-	-	-	-	-	E	-	-	-	-	-	-	-	-	-	-	-	-	-	-	-	-	-	-	-

ECSS Source Id	Req. Statement	ECSS Object Type	Verification			Inclusive requirements										Exclusive requirements													
			Verification Points (SRR, PDR, etc, see complete list at the end of this table)	Verification Methods (RoD, A, etc see complete list at the end of this table)	Recorded in [1] Electrical ICD (incl. SAR, Battery Antenna) [2] Budget document (e.g. Power, Energy, Processor, and memory budgets) [3] DDF or DJF [4] GDIR [5] Tests Report [6] Specification [7] User Manual [8] EIDP	SSE: Space Segment Element (physical view of Space Segment System)	SSS: Space segment sub-system	SSEq: Space Segment Equipment	LSE: Launch Segment Elements (physical view of Launch Segment System)	LSS: Launch Segment Subsystem	LSEq: Launch Segment Equipment	GSE: Ground Segment Elements (physical view of Ground Segment System)	GSS: Ground Segment Subsystems	GSEq: Ground Segment Equipment	Electrical Ground Support Equipment	Electrical Power Subsystem	Power Conditioning Unit	Power distribution and protection	Solar Array	Solar Array Drive Mechanism/Electronics	Battery	Battery management	Redundant	Switching converter	Generates/Receives telecommand	High Voltage	Single shot device	Circuit for single shot device	Antenna an RF chain
5.5.3e	The forward voltage of the string blocking diode (if present) shall be computed: 1using the worst-case voltage drop specified by the diode manufacturer, 2at the diode operating temperature corresponding to the operational string current for each mission phase in worst case conditions.	Requirement	PDR	A	[3]	>>	>>	//	-	-	-	-	-	-	-	-	-	E	-	-	-	-	-	-	-	-	-	-	-
5.5.3f	The BOL worst and best case power calculations shall include the parameters indicated in Table 5-1.	Requirement	PDR	RoD, A	[2][3]	>>	>>	//	-	-	-	-	-	-	-	-	-	E	-	-	-	-	-	-	-	-	-	-	-
5.5.3g	For best case calculations, the string current shall account for the difference between the specified current and the average production value.	Requirement	PDR	RoD, A	[2][3]	>>	>>	//	-	-	-	-	-	-	-	-	-	E	-	-	-	-	-	-	-	-	-	-	-
5.5.3h	In addition with the parameters indicated in Table 5-1, the EOL worst and best case calculations shall include the parameters indicated in Table 5-2.	Requirement	PDR	A	[2][3]	>>	>>	//	-	-	-	-	-	-	-	-	-	E	-	-	-	-	-	-	-	-	-	-	-
5.5.3i	Shadowing and hot spot phenomena shall be analysed.	Requirement	PDR	A	[2][3]	//	//	//	-	-	-	-	-	-	-	-	-	E	-	-	-	-	-	-	-	-	-	-	-
5.5.3j	Leakage losses of bypass diodes shall be deducted from the power computation if they represent more than 0,1 % of the overall power to be provided.	Requirement	PDR	A	[2][3]	>>	>>	//	-	-	-	-	-	-	-	-	-	E	-	-	-	-	-	-	-	-	-	-	-
5.5.3k	Plume impingement effects shall be analysed.	Requirement	PDR	A	[2][3]	//	//	//	-	-	-	-	-	-	-	-	-	E	-	-	-	-	-	-	-	-	-	-	-
5.5.4a	The qualified de-rated current capability of wires, connector pins and slip ring contacts shall be greater than the best case BOL solar array section current in short circuit and include the effects of transient currents caused by the discharge of the solar array section capacitance.	Requirement	PDR	RoD, A	[3]	>>	>>	//	-	-	-	-	-	-	-	-	-	E	-	-	-	-	-	-	-	-	-	-	-
5.5.4b	The design of the insulation barriers between adjacent wires, connector pins and slip rings shall be such that no discharge phenomena can occur.	Requirement	PDR	RoD, A	[3]	>>	>>	//	-	-	-	-	-	-	-	-	-	E	-	-	-	-	-	-	-	-	-	-	-
5.5.4c	Where non-insulated conductors are used, arcing phenomena shall be prevented by design.	Requirement	PDR	RoD, A	[3]	>>	>>	//	-	-	-	-	-	-	-	-	-	E	-	-	-	-	-	-	-	-	-	-	-
5.6.2a	The battery shall be specified to ensure the energy balance in each mission phase during operational life, including contingency modes resulting from a single failure for unmanned missions and two failures for manned missions.	Requirement	PDR	RoD, A	[1][2][3][6]	X	-	-	X	-	-	-	-	-	-	-	-	-	E	-	-	-	-	-	-	-	-	-	-

ECSS Source Id	Req. Statement	ECSS Object Type	Verification			Inclusive requirements										Exclusive requirements																						
			Verification Points (SRR, PDR, etc, see complete list at the end of this table)	Verification Methods (RoD, A, etc see complete list at the end of this table)	Recorded in [1] Electrical ICD (incl. SAR, Battery Antenna) [2] Budget document (e.g. Power, Energy, Processor, and memory budgets) [3] DDF or DJF [4] GDIR [5] Tests Report [6] Specification [7] User Manual [8] EIDP	SSE: Space Segment Element (physical view of Space Segment System)	SSS: Space segment sub-system	SSEq: Space Segment Equipment	LSE: Launch Segment Elements (physical view of Launch Segment System)	LSS: Launch Segment Subsystem	LSEq: Launch Segment Equipment	GSE: Ground Segment Elements (physical view of Ground Segment System)	GSS: Ground Segment Subsystems	GSEq: Ground Segment Equipment	Electrical Ground Support Equipment	Electrical Power Subsystem	Power Conditioning Unit	Power distribution and protection	Solar Array	Solar Array Drive Mechanism/Electronics	Battery	Battery management	Redundant	Switching converter	Generates/Receives telecommand	High Voltage	Single shot device	Circuit for single shot device	Antenna an RF chain									
5.6.2b	<<deleted>>	-	-	-	-	-	-	-	-	-	-	-	-	-	-	-	-	-	-	-	-	-	-	-	-	-	-	-	-	-	-	-	-	-	-	-	-	
5.6.2c	Specific measures shall be taken in the battery design to keep under control the series inductance and the magnetic moment.	Requirement	PDR	RoD, A	[3][6]	>>	>>	//	>>	>>	//	-	-	-	-	-	-	-	-	-	-	-	-	-	-	-	-	-	-	-	-	-	-	-	-	-	-	
5.6.2d	<<deleted>>	-	-	-	-	-	-	-	-	-	-	-	-	-	-	-	-	-	-	-	-	-	-	-	-	-	-	-	-	-	-	-	-	-	-	-	-	
5.6.2e	Batteries having to tolerate a single fault shall be designed such that they can operate with one cell either failed shorted or open circuit.	Requirement	PDR	RoD, A	[3]	>>	>>	//	>>	>>	//	-	-	-	-	-	-	-	-	-	-	-	-	-	-	-	-	-	-	-	-	-	-	-	-	-	-	-
5.6.2f	In batteries having to tolerate a single fault and where the effects of a single cell failure are mitigated by the use of a cell bypass device, the following shall be met: 1The probability of the bypass circuit untimely operation is lower than the probability of a failure of the cell. 2If the bypass operation is not instantaneous, the power subsystem design is able to operate without damage during the transient situation. 3The maximum number of cells that can be bypassed after a failure or a wrong command is equal to the number of failures allowed by the specific mission design.	Requirement	PDR	RoD, A	[1][2][3]	//	//	//	//	//	//	-	-	-	-	-	-	-	-	-	-	-	-	-	-	-	-	-	-	-	-	-	-	-	-	-	-	-
5.6.2g	Transient currents, occurring when two or more separate strings of series-connected cells are connected together in parallel, or when a cell fails in short-circuit within a battery composed of parallel strings, shall not result in exceeding the peak cell current rating.	Requirement	PDR	RoD, A	[3]	>>	//	//	>>	//	//	-	-	-	-	-	-	-	-	-	-	-	-	-	-	-	-	-	-	-	-	-	-	-	-	-	-	-
5.6.2h	Battery supplier shall: 1specify cell to cell performance variations so that mission requirements can be met, 2provide methodology and validation of cell performance variations for any spare or flight models 3provide methodology and validation of cell performance variations for any spare or flight models	Requirement	PDR	RoD, INS	[3][6]	>>	>>	//	>>	>>	//	-	-	-	-	-	-	-	-	-	-	-	-	-	-	-	-	-	-	-	-	-	-	-	-	-	-	-

ECSS Source Id	Req. Statement	ECSS Object Type	Verification			Inclusive requirements									Exclusive requirements																
			Verification Points (SRR, PDR, etc, see complete list at the end of this table)	Verification Methods (RoD, A, etc see complete list at the end of this table)	Recorded in [1] Electrical ICD (incl. SAR, Battery Antenna) [2] Budget document (e.g. Power, Energy, Processor, and memory budgets) [3] DDF or DJF [4] GDIR [5] Tests Report [6] Specification [7] User Manual [8] EIDP	SSE: Space Segment Element (physical view of Space Segment System)	SSS: Space segment sub-system	SSEq: Space Segment Equipment	LSE: Launch Segment Elements (physical view of Launch Segment System)	LSS: Launch Segment Subsystem	LSEq: Launch Segment Equipment	GSE: Ground Segment Elements (physical view of Ground Segment System)	GSS: Ground Segment Subsystems	GSEq: Ground Segment Equipment	Electrical Ground Support Equipment	Electrical Power Subsystem	Power Conditioning Unit	Power distribution and protection	Solar Array	Solar Array Drive Mechanism/Electronics	Battery	Battery management	Redundant	Switching converter	Generates/Receives telecommand	High Voltage	Single shot device	Circuit for single shot device	Antenna an RF chain		
5.6.2i	When batteries are discharged in parallel, this discharge shall not result in current and temperature exceeding the cell qualification limits.	Requirement	PDR	RoD, A	[3]	>>	//	//	>>	//	//	-	-	-	-	-	-	-	-	E	-	-	-	-	-	-	-	-	-	-	-
5.6.2j	Conducting cases of battery cells in a battery package shall be insulated from each other with reliable insulation.	Requirement	PDR	RoD	[3][5]	>>	>>	//	>>	>>	//	-	-	-	-	-	-	-	-	E	-	-	-	-	-	-	-	-	-	-	
5.6.2k	Provisions for interfacing the battery with the ground support equipment during pre-launch operations shall be made.	Requirement	PDR	RoD	[1][3]	>>	//	//	>>	//	//	-	-	-	-	-	-	-	-	E	-	-	-	-	-	-	-	-	-	-	
5.6.2l	A logbook shall be maintained by the supplier for each flight battery starting with the first activation after battery assembly up to launch, describing chronologically all test sequences, summary of observations, identification of related computer-based records, malfunctions, and references to test procedures and storage conditions.	Requirement	CDR	INS	[7]	>>	>>	//	>>	>>	//	-	-	-	-	-	-	-	-	E	-	-	-	-	-	-	-	-	-	-	
5.6.2m	Battery and spacecraft thermal design shall ensure together that: 1maximum and minimum qualification temperature of cell operation under intended cycling conditions are not exceeded; 2maximum qualification temperature gradients between different parts of the same cell and between two cells in a battery are not exceeded.	Requirement	PDR	RoD, A, T	[3][5]	//	//	//	//	//	//	-	-	-	-	-	-	-	-	E	-	-	-	-	-	-	-	-	-	-	
5.6.2n	<<deleted>> ECSS-E-ST-20_0020410	-	-	-	-	-	-	-	-	-	-	-	-	-	-	-	-	-	-	-	-	-	-	-	-	-	-	-	-	-	

ECSS Source Id	Req. Statement	ECSS Object Type	Verification			Inclusive requirements										Exclusive requirements													
			Verification Points (SRR, PDR, etc, see complete list at the end of this table)	Verification Methods (RoD, A, etc see complete list at the end of this table)	Recorded in [1] Electrical ICD (incl. SAR, Battery Antenna) [2] Budget document (e.g. Power, Energy, Processor, and memory budgets) [3] DDF or DJF [4] GDIR [5] Tests Report [6] Specification [7] User Manual [8] EIDP	SSE: Space Segment Element (physical view of Space Segment System)	SSS: Space segment sub-system	SSEq: Space Segment Equipment	LSE: Launch Segment Elements (physical view of Launch Segment System)	LSS: Launch Segment Subsystem	LSEq: Launch Segment Equipment	GSE: Ground Segment Elements (physical view of Ground Segment System)	GSS: Ground Segment Subsystems	GSEq: Ground Segment Equipment	Electrical Ground Support Equipment	Electrical Power Subsystem	Power Conditioning Unit	Power distribution and protection	Solar Array	Solar Array Drive Mechanism/Electronics	Battery	Battery management	Redundant	Switching converter	Generates/Receives telecommand	High Voltage	Single shot device	Circuit for single shot device	Antenna an RF chain
5.6.2o	Conductive cases of battery cells shall be reliably insulated from spacecraft structure, with an insulation between any cell and the spacecraft structure greater than 10 MΩ, measured at 500 V DC.	Requirement	PDR	RoD, T	-	>>	>>	//	>>	>>	//	-	-	-	-	-	-	-	-	E	-	-	-	-	-	-	-	-	-
5.6.3a	Absolute maximum ratings of the cell, in term of temperature, voltage, charge and discharge current in continuous and peak condition, shall be defined.	Requirement	PDR	RoD, A	[3][7]	>>	>>	//	>>	>>	//	-	-	-	-	-	-	-	-	E	-	-	-	-	-	-	-	-	
5.6.3b	The ability of a cell to meet mission lifetime requirements, where not covered by qualification life testing or previous in flight experience, shall be justified by the ground test data or by dedicated tests under representative conditions.	Requirement	PDR	RoD, A, T	[3]	>>	>>	//	>>	>>	//	-	-	-	-	-	-	-	-	E	-	-	-	-	-	-	-	-	
5.6.3c	The ability of a cell to meet mission life time requirements may be verified by similarity with qualification life testing or previous in flight experience only in case of identical design and identical manufacturing processes.	Permission	PDR	RoD, A	[3]	>>	>>	//	>>	>>	//	-	-	-	-	-	-	-	-	E	-	-	-	-	-	-	-	-	
5.6.3d	For any intended cell operation under acceleration greater than 1 g, the supplier shall ensure that no effect upon both short term (e.g. capacity) performance and lifetime can prevent battery nominal operation.	Requirement	PDR	A	[3]	>>	>>	//	>>	>>	//	-	-	-	-	-	-	-	-	E	-	-	-	-	-	-	-	-	
5.6.3e	<<deleted>>	-	-	-	-	-	-	-	-	-	-	-	-	-	-	-	-	-	-	-	-	-	-	-	-	-	-	-	
5.6.3f	<<deleted>>	-	-	-	-	-	-	-	-	-	-	-	-	-	-	-	-	-	-	-	-	-	-	-	-	-	-	-	
5.6.3g	The battery supplier shall inform the customer of any change in design, materials or process from cells which have experienced life testing or flight.	Requirement	PDR	RoD, INS	[3]	>>	>>	//	>>	>>	//	-	-	-	-	-	-	-	-	E	-	-	-	-	-	-	-	-	
5.6.4a	The design of the spacecraft shall be such that modules and batteries can be removed and replaced at any time prior to launch without affecting the acceptance status of the rest of the spacecraft.	Requirement	PDR	RoD, A	[3]	//	-	-	//	-	-	-	-	-	-	-	-	-	-	E	-	-	-	-	-	-	-	-	
5.6.4b	For the procurement of cells and batteries the manufacturer shall supply a user manual in conformance with Annex D.	Requirement	PDR	RoD	[7]	>>	>>	//	>>	>>	//	-	-	-	-	-	-	-	-	E	-	-	-	-	-	-	-	-	
5.6.4c	Flight batteries should not be used for ground operations to prevent any possible damage and subsequent degradation of life performance.	Recommendation	TRR	RoD	[3][6]	//	//	-	//	//	-	-	-	-	-	-	-	-	-	E	-	-	-	-	-	-	-	-	

ECSS Source Id	Req. Statement	ECSS Object Type	Verification			Inclusive requirements										Exclusive requirements													
			Verification Points (SRR, PDR, etc, see complete list at the end of this table)	Verification Methods (RoD, A, etc see complete list at the end of this table)	Recorded in [1] Electrical ICD (incl. SAR, Battery Antenna) [2] Budget document (e.g. Power, Energy, Processor, and memory budgets) [3] DDF or DJF [4] GDIR [5] Tests Report [6] Specification [7] User Manual [8] EIDP	SSE: Space Segment Element (physical view of Space Segment System)	SSS: Space segment sub-system	SSEq: Space Segment Equipment	LSE: Launch Segment Elements (physical view of Launch Segment System)	LSS: Launch Segment Subsystem	LSEq: Launch Segment Equipment	GSE: Ground Segment Elements (physical view of Ground Segment System)	GSS: Ground Segment Subsystems	GSEq: Ground Segment Equipment	Electrical Ground Support Equipment	Electrical Power Subsystem	Power Conditioning Unit	Power distribution and protection	Solar Array	Solar Array Drive Mechanism/Electronics	Battery	Battery management	Redundant	Switching converter	Generates/Receives telecommand	High Voltage	Single shot device	Circuit for single shot device	Antenna an RF chain
5.6.4d	If 5.6.4c is not met, the flight worthiness of the batteries shall be re-verified after these ground operations are completed, in time for a possible replacement.	Requirement	TRR	RoD, T	[5]	//	//	-	//	//	-	-	-	-	-	-	-	-	-	E	-	-	-	-	-	-	-	-	-
5.6.4e	Any test equipment interfacing with the battery shall include an associated undervoltage, overvoltage, overcurrent and over-temperature activated insulation switch.	Requirement	PDR	RoD, A, T	[3][5]	-	-	-	-	-	-	-	-	X	-	-	-	-	-	E	-	-	-	-	-	-	-	-	
5.6.4f	<<deleted>>	-	-	-	-	-	-	-	-	-	-	-	-	-	-	-	-	-	-	-	-	-	-	-	-	-	-	-	
5.6.4g	<<deleted>>	-	-	-	-	-	-	-	-	-	-	-	-	-	-	-	-	-	-	-	-	-	-	-	-	-	-	-	
5.6.5.2a	The battery safety shall be managed in conformance with ECSS-Q-ST-40.	Requirement	PDR	A	[3]	//	//	//	//	//	//	-	-	-	//	-	-	-	-	E	-	-	-	-	-	-	-	-	
5.6.5.2b	The design of the battery and associated monitoring and control electronics shall preclude the occurrence of any of the following: 1Over-temperature (from battery thermal dissipation or environmental heating); 2excessive currents (discharge or charge) including short-circuit (external or internal to the battery); 3overcharging; 4Attempt to charge in the case of primary cells; 5over discharge (including cell reversal); 6cell leakage (gases or electrolyte).	Requirement	PDR	RoD, A	[3]	//	//	//	//	//	//	-	-	-	//	-	-	-	-	E	E	-	-	-	-	-	-	-	
5.6.5.2c	Where 5.6.5.2b is not met, the design shall mitigate the damaging effects of any such failure mode	Requirement	PDR	RoD, A	[3]	//	//	//	//	//	//	-	-	-	//	-	-	-	-	E	E	-	-	-	-	-	-	-	
5.6.5.2d	The failure of one or more cells within a battery due to imbalance in the state of charge, temperature or other parameter between cells should be prevented by the battery control electronics.	Recommendation	PDR	RoD, A	[3]	//	//	//	//	//	//	-	-	-	//	-	-	-	-	E	E	-	-	-	-	-	-	-	
5.6.5.2e	When the battery has non-insulated, exposed cell terminals, the battery should be delivered with a red insulation cover to be removed before spacecraft closure and for flight.	Recommendation	PDR	RoD, INS	[1][3][7]	>>	>>	//	>>	>>	//	-	-	-	-	-	-	-	-	E	-	-	-	-	-	-	-	-	
5.6.5.2f	Provision should be made not to change the thermal balance of the battery during charge and discharge operations with the cover notified in 5.6.5.2e.	Recommendation	PDR	RoD, A	[3]	//	//	-	//	//	-	-	-	-	-	-	-	-	-	E	-	-	-	-	-	-	-	-	

ECSS Source Id	Req. Statement	ECSS Object Type	Verification			Inclusive requirements										Exclusive requirements													
			Verification Points (SRR, PDR, etc, see complete list at the end of this table)	Verification Methods (RoD, A, etc see complete list at the end of this table)	Recorded in [1] Electrical ICD (incl. SAR, Battery Antenna) [2] Budget document (e.g. Power, Energy, Processor, and memory budgets) [3] DDF or DJF [4] GDIR [5] Tests Report [6] Specification [7] User Manual [8] EIDP	SSE: Space Segment Element (physical view of Space Segment System)	SSS: Space segment sub-system	SSEq: Space Segment Equipment	LSE: Launch Segment Elements (physical view of Launch Segment System)	LSS: Launch Segment Subsystem	LSEq: Launch Segment Equipment	GSE: Ground Segment Elements (physical view of Ground Segment System)	GSS: Ground Segment Subsystems	GSEq: Ground Segment Equipment	Electrical Ground Support Equipment	Electrical Power Subsystem	Power Conditioning Unit	Power distribution and protection	Solar Array	Solar Array Drive Mechanism/Electronics	Battery	Battery management	Redundant	Switching converter	Generates/Receives telecommand	High Voltage	Single shot device	Circuit for single shot device	Antenna an RF chain
5.7.2a	No single failure shall result in the loss of the power subsystem capability to the extent that the minimum mission requirements, in any of its phases, cannot be fulfilled.	Requirement	PDR	RoD, A	[2][3]	X	//	//	X	//	//	-	-	-	-	-	-	-	-	-	-	-	-	-	-	-	-	-	-
5.7.2b	For manned missions, no double failure shall result in the loss of the power subsystem capability to the extent that the minimum mission requirements, in any of its phases, cannot be fulfilled.	Requirement	PDR	RoD, A	[2][3]	X	//	//	X	//	//	-	-	-	-	-	-	-	-	-	-	-	-	-	-	-	-	-	-
5.7.2c	The primary power bus voltage regulation control for a fully regulated bus shall be independent from any control external to the electrical power subsystem.	Requirement	PDR	RoD, A	[3]	X	//	//	X	//	//	-	-	-	-	-	-	-	-	-	-	-	-	-	-	-	-	-	
5.7.2d	The ultimate switching between main and redundant MPPT circuitry, in case of MPPT malfunction, shall be implemented in a way to avoid infinite reconfiguration loops.	Requirement	PDR	RoD, A	[3]	>>	//	//	>>	//	//	-	-	-	-	-	E	-	-	-	-	-	-	-	-	-	-	-	
5.7.2e	No single failure in the spacecraft shall open or short a main electrical power bus or violate the specified over voltage or under voltage limit requirements.	Requirement	PDR	RoD, A	[3]	X	//	//	X	//	//	-	-	-	-	-	-	-	-	-	-	-	-	-	-	-	-	-	
5.7.2f	The design shall ensure that under all conditions during the required lifetime, including operation in eclipse with one battery cell failure and one solar array string failed, the primary bus voltage remains within specified performances.	Requirement	PDR	RoD, A	[2][3]	X	//	//	X	//	//	-	-	-	-	-	-	-	-	-	-	-	-	-	-	-	-	-	

ECSS Source Id	Req. Statement	ECSS Object Type	Verification			Inclusive requirements								Exclusive requirements														
			Verification Points (SRR, PDR, etc, see complete list at the end of this table)	Verification Methods (RoD, A, etc see complete list at the end of this table)	Recorded in [1] Electrical ICD (incl. SAR, Battery Antenna) [2] Budget document (e.g. Power, Energy, Processor, and memory budgets) [3] DDF or DJF [4] GDIR [5] Tests Report [6] Specification [7] User Manual [8] EIDP	SSE: Space Segment Element (physical view of Space Segment System)	SSS: Space segment sub-system	SSEq: Space Segment Equipment	LSE: Launch Segment Elements (physical view of Launch Segment System)	LSS: Launch Segment Subsystem	LSEq: Launch Segment Equipment	GSE: Ground Segment Elements (physical view of Ground Segment System)	GSS: Ground Segment Subsystems	GSEq: Ground Segment Equipment	Electrical Ground Support Equipment	Electrical Power Subsystem	Power Conditioning Unit	Power distribution and protection	Solar Array	Solar Array Drive Mechanism/Electronics	Battery	Battery management	Redundant	Switching converter	Generates/Receives telecommand	High Voltage	Single shot device	Circuit for single shot device
5.7.2g	For fully regulated buses, the nominal bus voltage value should be standardized according to the following: 128 V for power up to 1,5 kW; 250 V for power up to 8 kW; 3100 V and 120 V for higher power.	Recommendation	PDR	RoD	[2][3]	//	//	//	//	//	//	-	-	-	-	-	-	-	-	-	-	-	-	-	-	-	-	-
5.7.2h	A fully regulated bus shall keep its nominal value in steady state within ± 0,5 % of the bus voltage at the main regulation point.	Requirement	PDR	RoD, A, T	[3][5]	>>	>>	//	>>	>>	//	-	-	-	-	E	-	-	-	-	-	-	-	-	-	-	-	-
5.7.2i	With a fully regulated bus in nominal operation the bus voltage transients shall: 1for load transients of up to 50 % of the nominal load not exceed 1 % of its nominal value. 2for any source and load transients remain within 5 % of its nominal value.Fuses should be avoided to maintain the quality of the bus.	Requirement	PDR	RoD, A, T	[3][5]	//	//	//	//	//	//	-	-	-	-	-	-	-	-	-	-	-	-	-	-	-	-	-

ECSS Source Id	Req. Statement	ECSS Object Type	Verification			Inclusive requirements									Exclusive requirements													
			Verification Points (SRR, PDR, etc, see complete list at the end of this table)	Verification Methods (RoD, A, etc see complete list at the end of this table)	Recorded in [1] Electrical ICD (incl. SAR, Battery Antenna) [2] Budget document (e.g. Power, Energy, Processor, and memory budgets) [3] DDF or DJF [4] GDIR [5] Tests Report [6] Specification [7] User Manual [8] EIDP	SSE: Space Segment Element (physical view of Space Segment System)	SSS: Space segment sub-system	SSEq: Space Segment Equipment	LSE: Launch Segment Elements (physical view of Launch Segment System)	LSS: Launch Segment Subsystem	LSEq: Launch Segment Equipment	GSE: Ground Segment Elements (physical view of Ground Segment System)	GSS: Ground Segment Subsystems	GSEq: Ground Segment Equipment	Electrical Ground Support Equipment	Electrical Power Subsystem	Power Conditioning Unit	Power distribution and protection	Solar Array	Solar Array Drive Mechanism/Electronics	Battery	Battery management	Redundant	Switching converter	Generates/Receives telecommand	High Voltage	Single shot device	Circuit for single shot device
5.7.2j	Fuses should be avoided to maintain the quality of the bus.	Recommendation	PDR	RoD	[3]	X	//	//	X	//	//	-	-	-	-	-	-	-	-	-	-	-	-	-	-	E	-	-
5.7.2k	In case of fuse blowing, the recovery from the fuse clearance shall not produce an overshoot of more than 10 % above the nominal bus value.	Requirement	PDR	A	[3]	//	//	//	//	//	//	-	-	-	-	-	-	-	-	-	-	-	-	-	-	E	-	-
5.7.2l	The model of the fuse and of the electrical network to be protected by the fuse, shall be validated by test with a representative set-up	Requirement	PDR	RoD, A, T	[3][5]	//	//	//	//	//	//	-	-	-	-	-	-	-	-	-	-	-	-	-	E	-	-	
5.7.2m	A fully regulated bus shall have a nominal ripple voltage below 0,5 % peak-to-peak of the nominal bus voltage, measured at the regulation point with at least 1 MHz bandwidth.	Requirement	PDR	RoD, A, T	[3][5]	>>	>>	//	>>	>>	//	-	-	-	-	E	-	-	-	-	-	-	-	-	-	-	-	-
5.7.2n	A fully regulated bus shall have commutation voltage spikes in the time domain of less than 2 % peak-to-peak of the nominal bus voltage, measured at the regulation point with a 50 MHz minimum bandwidth.	Requirement	PDR	RoD, A, T	[3][5]	>>	>>	//	>>	>>	//	-	-	-	-	E	-	-	-	-	-	-	-	-	-	-	-	-
5.7.2o	At the point of regulation, the impedance mask of a fully regulated bus, operating with one source shall be below the impedance mask shown in Figure 5-1.	Requirement	PDR	RoD, A, T	[3][5]	>>	>>	//	>>	>>	//	-	-	-	-	E	-	-	-	-	-	-	-	-	-	-	-	-

ECSS Source Id	Req. Statement	ECSS Object Type	Verification			Inclusive requirements									Exclusive requirements													
			Verification Points (SRR, PDR, etc, see complete list at the end of this table)	Verification Methods (RoD, A, etc see complete list at the end of this table)	Recorded in [1] Electrical ICD (incl. SAR, Battery Antenna) [2] Budget document (e.g. Power, Energy, Processor, and memory budgets) [3] DDF or DJF [4] GDIR [5] Tests Report [6] Specification [7] User Manual [8] EIDP	SSE: Space Segment Element (physical view of Space Segment System)	SSS: Space segment sub-system	SSEQ: Space Segment Equipment	LSE: Launch Segment Elements (physical view of Launch Segment System)	LSS: Launch Segment Subsystem	LSEQ: Launch Segment Equipment	GSE: Ground Segment Elements (physical view of Ground Segment System)	GSS: Ground Segment Subsystems	GSEQ: Ground Segment Equipment	Electrical Ground Support Equipment	Electrical Power Subsystem	Power Conditioning Unit	Power distribution and protection	Solar Array	Solar Array Drive Mechanism/Electronics	Battery	Battery management	Redundant	Switching converter	Generates/Receives telecommand	High Voltage	Single shot device	Circuit for single shot device
5.7.2p	For unregulated buses, the following parameters shall be specified, analysed and tested: 1 maximum and minimum bus voltage guaranteed at payload level in all steady state and transients conditions; 2 maximum ripple in time domain, measured with at least 1 MHz bandwidth. 3 maximum spikes in the time domain superimposed on the bus voltage, measured with a 50 MHz minimum bandwidth. 4 impedance mask.	Requirement	PDR	RoD, A, T	[3][5][6]	//	//	//	//	//	-	-	-	-	-	-	-	-	-	-	-	-	-	-	-	-	-	-
5.7.2q	During integration phase the power subsystem shall be able to start up from any of its power sources irrespective of the connection of the other power source.	Requirement	PDR	RoD, A, T	[3][5]	>>	//	//	>>	//	//	-	-	-	-	-	E	-	-	-	-	-	-	-	-	-	-	-
5.7.2r	In the case of an unexpected battery or battery simulator disconnection, the main power bus voltage shall remain below its maximum specified overvoltage requirement.	Requirement	PDR	RoD, A, T	[3][5]	>>	//	//	>>	//	//	-	-	-	//	-	E	-	-	-	-	-	-	-	-	-	-	-
5.7.2s	The design shall ensure that a short circuit to ground or to the return line of a solar array section does not result in a failure of category 1 and 2 criticality.	Requirement	PDR	RoD, A	[3]	>>	//	//	>>	//	//	-	-	-	-	-	E	-	-	-	-	-	-	-	-	-	-	-
5.7.2t	Control of the battery by OBC shall be robust to OBC failure and the time needed to reconfigure.	Requirement	PDR	RoD, A	[3]	>>	//	//	>>	//	//	-	-	-	-	-	-	-	-	-	-	-	-	-	-	-	-	-

ECSS Source Id	Req. Statement	ECSS Object Type	Verification			Inclusive requirements									Exclusive requirements														
			Verification Points (SRR, PDR, etc, see complete list at the end of this table)	Verification Methods (RoD, A, etc see complete list at the end of this table)	Recorded in [1] Electrical ICD (incl. SAR, Battery Antenna) [2] Budget document (e.g. Power, Energy, Processor, and memory budgets) [3] DDF or DJF [4] GDIR [5] Tests Report [6] Specification [7] User Manual [8] EIDP	SSE: Space Segment Element (physical view of Space Segment System)	SSS: Space segment sub-system	SSEq: Space Segment Equipment	LSE: Launch Segment Elements (physical view of Launch Segment System)	LSS: Launch Segment Subsystem	LSEq: Launch Segment Equipment	GSE: Ground Segment Elements (physical view of Ground Segment System)	GSS: Ground Segment Subsystems	GSEq: Ground Segment Equipment	Electrical Ground Support Equipment	Electrical Power Subsystem	Power Conditioning Unit	Power distribution and protection	Solar Array	Solar Array Drive Mechanism/Electronics	Battery	Battery management	Redundant	Switching converter	Generates/Receives telecommand	High Voltage	Single shot device	Circuit for single shot device	Antenna an RF chain
5.7.3a	On-board battery chargers shall be designed to ensure charging of a battery discharged down to zero volts.	Requirement	PDR	RoD, A, T	[3][5]	>>	>>	//	>>	>>	//	-	-	-	-	E	-	-	-	-	-	-	-	-	-	-	-	-	-
5.7.3b	<<deleted>>	-	-	-	-	-	-	-	-	-	-	-	-	-	-	-	-	-	-	-	-	-	-	-	-	-	-	-	-
5.7.3c	The minimum energy reserve in the battery shall be enough to guarantee the mission and a safe recovery of the spacecraft under all conditions.	Requirement	PDR	RoD, A	[3][2]	X	-	-	X	-	-	-	-	-	-	-	-	-	-	-	-	-	-	-	-	-	-	-	-
5.7.3d	The charging technique shall be designed to ensure that the batteries are managed in accordance with the manufacturer recommendations provided in the design description, justification file and user's manual.	Requirement	PDR	RoD, A	[3]	>>	//	//	>>	//	//	-	-	-	//	-	-	-	-	-	E	-	-	-	-	-	-	-	-
5.7.3e	<<deleted>>	-	-	-	-	-	-	-	-	-	-	-	-	-	-	-	-	-	-	-	-	-	-	-	-	-	-	-	-
5.7.3f	<<deleted>>	-	-	-	-	-	-	-	-	-	-	-	-	-	-	-	-	-	-	-	-	-	-	-	-	-	-	-	-
5.7.3g	<<deleted>>The ultimate over charging/discharging protection circuitry shall be implemented by hardware and independent from any on board software.	-	-	-	-	-	-	-	-	-	-	-	-	-	-	-	-	-	-	-	-	-	-	-	-	-	-	-	-
5.7.3h	The ultimate over charging/discharging protection circuitry shall be implemented by hardware and independent from any on board software.	Requirement	PDR	RoD, A	[3]	>>	>>	//	>>	>>	//	-	-	-	-	-	-	-	-	-	E	-	-	-	-	-	-	-	-
5.7.3i	Battery charge and discharge management shall be such that a single failure for unmanned missions and two failures for manned missions does not impair the lifetime of the energy storage system with respect to minimum or maximum voltage as well as maximum charge or maximum discharge current.	Requirement	PDR	RoD, A	[3]	>>	//	//	>>	//	//	-	-	-	-	E	-	-	-	-	-	-	-	-	-	-	-	-	-

ECSS Source Id	Req. Statement	ECSS Object Type	Verification			Inclusive requirements								Exclusive requirements														
			Verification Points (SRR, PDR, etc, see complete list at the end of this table)	Verification Methods (RoD, A, etc see complete list at the end of this table)	Recorded in [1] Electrical ICD (incl. SAR, Battery Antenna) [2] Budget document (e.g. Power, Energy, Processor, and memory budgets) [3] DDF or DJF [4] GDIR [5] Tests Report [6] Specification [7] User Manual [8] EIDP	SSE: Space Segment Element (physical view of Space Segment System)	SSS: Space segment sub-system	SSEq: Space Segment Equipment	LSE: Launch Segment Elements (physical view of Launch Segment System)	LSS: Launch Segment Subsystem	LSEq: Launch Segment Equipment	GSE: Ground Segment Elements (physical view of Ground Segment System)	GSS: Ground Segment Subsystems	GSEq: Ground Segment Equipment	Electrical Ground Support Equipment	Electrical Power Subsystem	Power Conditioning Unit	Power distribution and protection	Solar Array	Solar Array Drive Mechanism/Electronics	Battery	Battery management	Redundant	Switching converter	Generates/Receives telecommand	High Voltage	Single shot device	Circuit for single shot device
5.7.4a	For fuse protected busses the electrical subsystem shall be robust against any fuse blowing event occurring on the primary bus, even after one failure anywhere in the power subsystem.	Requirement	PDR	RoD, A, T	[3][5]	//	//	//	//	//	//	-	-	-	-	-	-	-	-	-	-	-	-	-	-	E	-	-
5.7.4b	All non-essential loads shall be switched-off autonomously in the event of reaching the battery energy level that is able to maintain all essential loads for a time guaranteeing safe recovery.	Requirement	PDR	RoD, A, T	[3][5]	//	//	//	//	//	//	-	-	-	-	-	-	-	-	-	-	-	-	-	-	-	-	-
5.7.4c	The ultimate non-essential load disconnection circuit shall be implemented as a full hard-wired chain from sensor to actuator.	Requirement	PDR	RoD, A	[3][6]	//	//	//	//	//	//	-	-	-	-	-	-	-	-	-	-	-	-	-	-	-	-	-
5.7.4d	The ultimate non-essential load disconnection circuit shall be one failure tolerant if centralised.	Requirement	PDR	RoD, A	[3][6]	//	//	//	//	//	//	-	-	-	-	-	-	-	-	-	-	-	-	-	-	-	-	-
5.7.4e	The spacecraft design shall be such that in the event of an under-voltage condition on the bus, no failure is induced in the power subsystem or the loads during and when recovering from this under-voltage.	Requirement	PDR	RoD, A	[3]	//	//	//	//	//	//	-	-	-	-	-	-	-	-	-	-	-	-	-	-	-	-	-
5.7.4f	After recovery as mentioned in 5.7.4e the loads shall be as follows: 1 all essential loads be supplied nominally; 2 all non-essential loads be in a known configuration that cannot create damage to any part of the spacecraft.	Requirement	PDR	RoD, A, T	[3][5]	//	//	//	//	//	//	-	-	-	-	-	-	-	-	-	-	-	-	-	-	-	-	-

ECSS Source Id	Req. Statement	ECSS Object Type	Verification			Inclusive requirements									Exclusive requirements														
			Verification Points (SRR, PDR, etc, see complete list at the end of this table)	Verification Methods (RoD, A, etc see complete list at the end of this table)	Recorded in [1] Electrical ICD (incl. SAR, Battery Antenna) [2] Budget document (e.g. Power, Energy, Processor, and memory budgets) [3] DDF or DJF [4] GDIR [5] Tests Report [6] Specification [7] User Manual [8] EIDP	SSE: Space Segment Element (physical view of Space Segment System)	SSS: Space segment sub-system	SSEq: Space Segment Equipment	LSE: Launch Segment Elements (physical view of Launch Segment System)	LSS: Launch Segment Subsystem	LSEq: Launch Segment Equipment	GSE: Ground Segment Elements (physical view of Ground Segment System)	GSS: Ground Segment Subsystems	GSEq: Ground Segment Equipment	Electrical Ground Support Equipment	Electrical Power Subsystem	Power Conditioning Unit	Power distribution and protection	Solar Array	Solar Array Drive Mechanism/Electronics	Battery	Battery management	Redundant	Switching converter	Generates/Receives telecommand	High Voltage	Single shot device	Circuit for single shot device	Antenna an RF chain
5.8.2h	There shall be umbilical and test connectors to provide external electrical interfaces.	Requirement	PDR	RoD, INS	[3]	X	//	//	X	//	//	-	-	-	//	-	-	-	-	-	-	-	-	-	-	-	-	-	-
5.8.2i	Electrical and Safe and arm plugs shall be provided for disabling on ground hazard functions.	Requirement	PDR	RoD, INS	[3]	X	//	//	X	//	//	-	-	-	//	-	-	-	-	-	-	-	-	-	-	-	-	-	
5.8.2j	If cross-strapping of redundant paths and circuits is carried out in the harness, then provisions of ECSS-E-ST-50-14 clause 4.2.5.2 shall apply.	Requirement	PDR	RoD, INS	[3]	//	//	-	//	//	-	-	-	-	-	-	-	-	-	-	-	-	-	-	-	-	-	-	
5.9a	The design of electrical subsystems and payloads shall conform to ECSS-Q-ST-40.	Requirement	-	-	-	X	X	X	X	X	X	-	-	-	//	-	-	-	-	-	-	-	-	-	-	-	-	-	-
5.10a	For non pressurised and non potted high voltage equipment, the applicable pressure range when this equipment is on shall be specified.	Requirement	SRR	RoD	[6]	>>	//	//	>>	//	//	-	-	-	-	-	-	-	-	-	-	-	-	E	-	-	-	-	
5.10b	Non pressurised and non potted high voltage equipment shall be designed and manufactured to avoid discharge phenomena according to Paschen curves valid for its specified pressure range.	Requirement	PDR	RoD, A	[3]	>>	//	//	>>	//	//	-	-	-	-	-	-	-	-	-	-	-	E	-	-	-	-		
5.10c	The field enhancement factors shall be ensured by the design.	Requirement	PDR	RoD, A	[3]	>>	//	//	>>	//	//	-	-	-	-	-	-	-	-	-	-	-	E	-	-	-	-		
5.10d	For potted circuits, the glass transition point of the potting material shall be outside the temperature range of qualification.	Requirement	PDR	RoD, A	[3]	>>	>>	//	>>	>>	//	-	-	-	-	-	-	-	-	-	-	-	E	-	-	-	-		
5.10e	The design of high voltage equipment shall be such that worst case DC and AC field strengths are less than half of the values for which breakdown can occur.	Requirement	PDR	RoD, A	[3]	>>	>>	//	>>	>>	//	-	-	-	-	-	-	-	-	-	-	-	E	-	-	-	-		
5.11.1a	The requirements of this Clause 5 should be verified by the verification methods and at the verification points listed in Table 8-3.	Recommendation	-	-	-	X	X	X	X	X	X	-	-	-	-	-	-	-	-	-	-	-	-	-	-	-	-	-	
5.11.2a	<<deleted>>	-	-	-	-	-	-	-	-	-	-	-	-	-	-	-	-	-	-	-	-	-	-	-	-	-	-	-	

ECSS Source Id	Req. Statement	ECSS Object Type	Verification			Inclusive requirements									Exclusive requirements															
			Verification Points (SRR, PDR, etc, see complete list at the end of this table)	Verification Methods (RoD, A, etc see complete list at the end of this table)	Recorded in [1] Electrical ICD (incl. SAR, Battery Antenna) [2] Budget document (e.g. Power, Energy, Processor, and memory budgets) [3] DDF or DJF [4] GDIR [5] Tests Report [6] Specification [7] User Manual [8] EIDP	SSE: Space Segment Element (physical view of Space Segment System)	SSS: Space segment sub-system	SSEq: Space Segment Equipment	LSE: Launch Segment Elements (physical view of Launch Segment System)	LSS: Launch Segment Subsystem	LSEq: Launch Segment Equipment	GSE: Ground Segment Elements (physical view of Ground Segment System)	GSS: Ground Segment Subsystems	GSEq: Ground Segment Equipment	Electrical Ground Support Equipment	Electrical Power Subsystem	Power Conditioning Unit	Power distribution and protection	Solar Array	Solar Array Drive Mechanism/Electronics	Battery	Battery management	Redundant	Switching converter	Generates/Receives telecommand	High Voltage	Single shot device	Circuit for single shot device	Antenna an RF chain	
7.2.2.1a	The antenna category (7.2.2.2), composing elements (7.2.2.4), used technologies (7.2.2.4) and the performance parameters (7.2.2.5) shall be established at the beginning of the project phase B.	Requirement	PDR, CDR	RoD	[3]	X	-	-	X	-	-	-	-	-	-	-	-	-	-	-	-	-	-	-	-	-	-	-	-	E
7.2.2.2.1a	The antenna radiation pattern shall be characterised including the scattering effects of all surrounding structures.	Requirement	PDR, CDR	A, T	[3][5]	X	//	-	X	//	-	-	-	-	-	-	-	-	-	-	-	-	-	-	-	-	-	-	E	
7.2.2.2.1b	If a number of TT&C antennas operate simultaneously, the combined radiation pattern shall be used in the performance evaluation.	Requirement	PDR, CDR	A, T	[3][5]	X	//	-	X	//	-	-	-	-	-	-	-	-	-	-	-	-	-	-	-	-	-	-	E	
7.2.2.2.2a	The reflection and transmission properties (losses, depolarisation and diffusivity) of the reflecting or transmitting elements shall be quantified and their impact on antenna performances assessed.	Requirement	PDR, CDR	A, T	[3][5]	X	//	-	X	//	-	-	-	-	-	-	-	-	-	-	-	-	-	-	-	-	-	-	E	
7.2.2.2.2b	The effects of antenna support structures shall be quantified and the impact on antenna performances assessed.	Requirement	PDR, CDR	A, T	[3][5]	X	//	//	X	//	//	-	-	-	-	-	-	-	-	-	-	-	-	-	-	-	-	-	E	
7.2.2.2.2c	Deformations of reflector antennas, which parts are physically attached to different portions of the spacecraft platform, shall be quantified and their impact on antenna performance assessed.	Requirement	PDR, CDR	A, T	[3][5]	X	//	//	X	//	//	-	-	-	-	-	-	-	-	-	-	-	-	-	-	-	-	-	E	

ECSS Source Id	Req. Statement	ECSS Object Type	Verification			Inclusive requirements									Exclusive requirements															
			Verification Points (SRR, PDR, etc, see complete list at the end of this table)	Verification Methods (RoD, A, etc see complete list at the end of this table)	Recorded in [1] Electrical ICD (incl. SAR, Battery Antenna) [2] Budget document (e.g. Power, Energy, Processor, and memory budgets) [3] DDF or DJF [4] GDIR [5] Tests Report [6] Specification [7] User Manual [8] EIDP	SSE: Space Segment Element (physical view of Space Segment System)	SSS: Space segment sub-system	SSEq: Space Segment Equipment	LSE: Launch Segment Elements (physical view of Launch Segment System)	LSS: Launch Segment Subsystem	LSEq: Launch Segment Equipment	GSE: Ground Segment Elements (physical view of Ground Segment System)	GSS: Ground Segment Subsystems	GSEq: Ground Segment Equipment	Electrical Ground Support Equipment	Electrical Power Subsystem	Power Conditioning Unit	Power distribution and protection	Solar Array	Solar Array Drive Mechanism/Electronics	Battery	Battery management	Redundant	Switching converter	Generates/Receives telecommand	High Voltage	Single shot device	Circuit for single shot device	Antenna an RF chain	
7.2.2.3.1d	It shall be demonstrated that the scattering of the radiation pattern of individual radiating elements does not affect the accuracy of all radiated performance measurement.	Requirement	PDR, CDR	A	[3][5]	-	-	//	-	-	//	-	-	-	-	-	-	-	-	-	-	-	-	-	-	-	-	-	-	E
7.2.2.3.1e	Thermal dissipation of RF power shall be quantified and the impact on antenna performances assessed.	Requirement	PDR, CDR, QTR, AR	A, T	[3][5]	-	-	//	-	-	//	-	-	-	-	-	-	-	-	-	-	-	-	-	-	-	-	-	E	
7.2.2.3.1f	Whenever a radiating element is used to route high power levels,	Requirement	PDR, CDR, QTR, AR	A, T	[3][5]	-	-	//	-	-	//	-	-	-	-	-	-	-	-	-	-	-	-	-	-	-	-	-	E	
7.2.2.3.1g	All metallic parts in a radiating element shall be connected to the equipment DC ground to avoid electrostatic discharge (ESD).	Requirement	PDR, CDR, QTR, AR	RoD, T	[1][5]	-	-	//	-	-	//	-	-	-	-	-	-	-	-	-	-	-	-	-	-	-	-	-	E	
7.2.2.3.2a	Reflective properties (losses, depolarisation, and diffusivity) of the materials and composites used shall be quantified and their impact on antenna performances assessed.	Requirement	PDR, CDR	A, T	[3][5]	-	-	//	-	-	//	-	-	-	-	-	-	-	-	-	-	-	-	-	-	-	-	-	E	
7.2.2.3.2b	The reflective and transmissive properties (losses, depolarisation, diffusivity) of the materials and composites used for polarisation and frequency selective reflectors shall be quantified and their impact on antenna performances assessed.	Requirement	PDR, CDR	A, T	[3][5]	-	-	//	-	-	//	-	-	-	-	-	-	-	-	-	-	-	-	-	-	-	-	-	E	
7.2.2.3.2c	Deviations from the nominal geometry of the reflector shall be quantified and their impact on antenna performances assessed.	Requirement	PDR, CDR	A	[3][5]	-	-	//	-	-	//	-	-	-	-	-	-	-	-	-	-	-	-	-	-	-	-	-	E	

ECSS Source Id	Req. Statement	ECSS Object Type	Verification			Inclusive requirements										Exclusive requirements													
			Verification Points (SRR, PDR, etc, see complete list at the end of this table)	Verification Methods (RoD, A, etc see complete list at the end of this table)	Recorded in [1] Electrical ICD (incl. SAR, Battery Antenna) [2] Budget document (e.g. Power, Energy, Processor, and memory budgets) [3] DDF or DJF [4] GDIR [5] Tests Report [6] Specification [7] User Manual [8] EIDP	SSE: Space Segment Element (physical view of Space Segment System)	SSS: Space segment sub-system	SSEq: Space Segment Equipment	LSE: Launch Segment Elements (physical view of Launch Segment System)	LSS: Launch Segment Subsystem	LSEq: Launch Segment Equipment	GSE: Ground Segment Elements (physical view of Ground Segment System)	GSS: Ground Segment Subsystems	GSEq: Ground Segment Equipment	Electrical Ground Support Equipment	Electrical Power Subsystem	Power Conditioning Unit	Power distribution and protection	Solar Array	Solar Array Drive Mechanism/Electronics	Battery	Battery management	Redundant	Switching converter	Generates/Receives telecommand	High Voltage	Single shot device	Circuit for single shot device	Antenna an RF chain
7.2.2.3.3a	Reflective and transmissive properties of the materials and composites used for the lenses shall be quantified and their impact on antenna performances assessed.	Requirement	PDR, CDR	A, T	[3][5]	-	-	//	-	-	//	-	-	-	-	-	-	-	-	-	-	-	-	-	-	-	-	-	E
7.2.2.3.3b	Deviations from the nominal geometry of the lens shall be quantified and their impact on antenna performances assessed.	Requirement	PDR, CDR	A	[3]	-	-	//	-	-	//	-	-	-	-	-	-	-	-	-	-	-	-	-	-	-	-	-	E
7.2.2.3.3c	Measures to drain accumulated electric charges from all non conductive parts shall be implemented to avoid electrostatic discharge (ESD).	Requirement	PDR, CDR, QTR, AR	RoD, T	[3][4][1]	-	-	//	-	-	//	-	-	-	-	-	-	-	-	-	-	-	-	-	-	-	-	E	
7.2.2.3.3d	Any metallic parts shall be connected to the equipment DC ground to avoid electrostatic discharge (ESD).	Requirement	PDR, CDR, QTR, AR	RoD, T	[3][5][1]	-	-	//	-	-	//	-	-	-	-	-	-	-	-	-	-	-	-	-	-	-	-	E	
7.2.2.3.4a	The circuit characteristics of the RF BFN shall be independently quantified and their impact on antenna performances assessed at least up to CDR.	Requirement	PDR, CDR	A, T	[3][5]	-	//	//	-	//	//	-	-	-	-	-	-	-	-	-	-	-	-	-	-	-	-	E	
7.2.2.3.4b	Deviations from the nominal geometry of the RF BFN shall be quantified and their impact on antenna performances assessed.	Requirement	PDR, CDR	A	[3]	-	//	//	-	//	//	-	-	-	-	-	-	-	-	-	-	-	-	-	-	-	-	E	
7.2.2.3.4c	In all RF BFN structures having a central conductor (ideally insulated), the thermal power generated by Joule effect on the conductor itself shall be quantified and its impact on antenna performances assessed.	Requirement	PDR, CDR	A	[3]	-	//	//	-	//	//	-	-	-	-	-	-	-	-	-	-	-	-	-	-	-	-	E	
7.2.2.3.4d	For RF BFN, the applicable pressure range and gas properties shall be specified.	Requirement	PDR, CDR, QTR, AR	A, T, RoD	[3][5][8]	-	//	//	-	//	//	-	-	-	-	-	-	-	-	-	-	-	-	-	-	-	-	E	

ECSS Source Id	Req. Statement	ECSS Object Type	Verification			Inclusive requirements										Exclusive requirements														
			Verification Points (SRR, PDR, etc, see complete list at the end of this table)	Verification Methods (RoD, A, etc see complete list at the end of this table)	Recorded in [1] Electrical ICD (incl. SAR, Battery Antenna) [2] Budget document (e.g. Power, Energy, Processor, and memory budgets) [3] DDF or DJF [4] GDIR [5] Tests Report [6] Specification [7] User Manual [8] EIDP	SSE: Space Segment Element (physical view of Space Segment System)	SSS: Space segment sub-system	SSEq: Space Segment Equipment	LSE: Launch Segment Elements (physical view of Launch Segment System)	LSS: Launch Segment Subsystem	LSEq: Launch Segment Equipment	GSE: Ground Segment Elements (physical view of Ground Segment System)	GSS: Ground Segment Subsystems	GSEq: Ground Segment Equipment	Electrical Ground Support Equipment	Electrical Power Subsystem	Power Conditioning Unit	Power distribution and protection	Solar Array	Solar Array Drive Mechanism/Electronics	Battery	Battery management	Redundant	Switching converter	Generates/Receives telecommand	High Voltage	Single shot device	Circuit for single shot device	Antenna an RF chain	
7.2.2.3.4e	For RF BFN, the design and manufacturing shall be performed to avoid discharge phenomena according to Paschen curves valid for its specified pressure range and gas properties.	Requirement	PDR, CDR, QTR, AR	A, T, RoD	[3][5][8]	-	//	//	-	//	//	-	-	-	-	-	-	-	-	-	-	-	-	-	-	-	-	-	-	E
7.2.2.3.5a	The circuit characteristics of the antenna RF chain shall be independently quantified and their impact on antenna performances assessed at least up to CDR.	Requirement	PDR, CDR	A, T	[3][5]	-	//	//	-	//	//	-	-	-	-	-	-	-	-	-	-	-	-	-	-	-	-	-	-	E
7.2.2.3.5b	The cumulative effects of wave propagation discontinuities along the whole antenna RF chain, including the radiating elements attached to it, shall be quantified and the impact on antenna performances assessed.	Requirement	PDR, CDR	A, T	[3][5]	-	//	//	-	//	//	-	-	-	-	-	-	-	-	-	-	-	-	-	-	-	-	-	-	E
7.2.2.3.5c	For antenna RF chain the applicable pressure range and gas properties shall be specified.	Requirement	PDR, CDR, QTR, AR	A, T, RoD	[3][5][8]	-	//	//	-	//	//	-	-	-	-	-	-	-	-	-	-	-	-	-	-	-	-	-	-	E
7.2.2.3.5d	For antenna RF chain the design and manufacturing shall be performed to avoid discharge phenomena according to Paschen curves valid for its specified pressure range and gas properties.	Requirement	PDR, CDR, QTR, AR	A, T, RoD	[3][5][8]	-	//	//	-	//	//	-	-	-	-	-	-	-	-	-	-	-	-	-	-	-	-	-	-	E
7.2.2.3.6a	The possible scattering effects of the support structures shall be quantified and their impact on the antenna performances assessed.	Requirement	PDR, CDR	A, T	[3][5]	-	-	//	-	-	//	-	-	-	-	-	-	-	-	-	-	-	-	-	-	-	-	-	-	E
7.2.2.3.6b	Deviations from the nominal geometry of the supporting structure shall be quantified and their impact on antenna performances assessed.	Requirement	PDR, CDR	A, T	[3][5]	-	-	//	-	-	//	-	-	-	-	-	-	-	-	-	-	-	-	-	-	-	-	-	-	E
7.2.2.4.1a	The level of passive inter-modulation products generated by the antenna shall be quantified and their impact on antenna performances assessed.	Requirement	PDR, CDR, QTR, AR	A, T, RoD	[3][5][8]	-	-	//	-	-	//	-	-	-	-	-	-	-	-	-	-	-	-	-	-	-	-	-	-	E

ECSS Source Id	Req. Statement	ECSS Object Type	Verification			Inclusive requirements									Exclusive requirements														
			Verification Points (SRR, PDR, etc, see complete list at the end of this table)	Verification Methods (RoD, A, etc see complete list at the end of this table)	Recorded in [1] Electrical ICD (incl. SAR, Battery Antenna) [2] Budget document (e.g. Power, Energy, Processor, and memory budgets) [3] DDF or DJF [4] GDIR [5] Tests Report [6] Specification [7] User Manual [8] EIDP	SSE: Space Segment Element (physical view of Space Segment System)	SSS: Space segment sub-system	SSEq: Space Segment Equipment	LSE: Launch Segment Elements (physical view of Launch Segment System)	LSS: Launch Segment Subsystem	LSEq: Launch Segment Equipment	GSE: Ground Segment Elements (physical view of Ground Segment System)	GSS: Ground Segment Subsystems	GSEq: Ground Segment Equipment	Electrical Ground Support Equipment	Electrical Power Subsystem	Power Conditioning Unit	Power distribution and protection	Solar Array	Solar Array Drive Mechanism/Electronics	Battery	Battery management	Redundant	Switching converter	Generates/Receives telecommand	High Voltage	Single shot device	Circuit for single shot device	Antenna an RF chain
7.2.2.4.1b	The impact of thermally-induced effects on the generation of passive intermodulation products shall be quantified and the impact on antenna performances assessed.	Requirement	PDR, CDR, QTR, AR	A, T, RoD	[3][5][8]	//	//	//	//	//	-	-	-	-	-	-	-	-	-	-	-	-	-	-	-	-	-	-	E
7.2.2.4.1c	Thermally induced changes of dimension and shape in all metallic antenna parts shall be quantified and their impact on antenna performances assessed.	Requirement	PDR, CDR	A	[3]	-	-	//	-	-	//	-	-	-	-	-	-	-	-	-	-	-	-	-	-	-	-	-	E
7.2.2.4.2a	The impact of surface characteristics and finish on antenna performances shall be assessed.	Requirement	PDR, CDR	A	[3]	-	-	//	-	-	//	-	-	-	-	-	-	-	-	-	-	-	-	-	-	-	-	-	E
7.2.2.4.2b	Thermally induced changes of dimension and shape in all composite and combined metal-composite antenna parts shall be quantified and their impact on antenna performances assessed.	Requirement	PDR, CDR	A	[3]	-	-	//	-	-	//	-	-	-	-	-	-	-	-	-	-	-	-	-	-	-	-	-	E
7.2.2.4.2c	Measures to drain accumulated electric charges from composite parts shall be implemented to avoid electrostatic discharge (ESD).	Requirement	PDR, CDR, QTR, AR	T, RoD	[3][5][8]	-	-	//	-	-	//	-	-	-	-	-	-	-	-	-	-	-	-	-	-	-	-	-	E
7.2.2.4.3a	The dielectric losses of plastic component in the RF power path shall be quantified and their impact on antenna performances assessed.	Requirement	PDR, CDR	A, T	[3][5]	-	-	//	-	-	//	-	-	-	-	-	-	-	-	-	-	-	-	-	-	-	-	-	E
7.2.2.4.3b	Thermally induced changes of dimension and shape in all plastic and combined metal-plastic antenna parts shall be quantified and their impact on antenna performances assessed.	Requirement	PDR, CDR	A	[3]	-	-	//	-	-	//	-	-	-	-	-	-	-	-	-	-	-	-	-	-	-	-	-	E
7.2.2.4.3c	Measures to drain accumulated electric charges from all plastic parts shall be implemented to avoid electrostatic discharge (ESD).	Requirement	PDR, CDR, QTR, AR	T, RoD	[3][5][8]	-	-	//	-	-	//	-	-	-	-	-	-	-	-	-	-	-	-	-	-	-	-	-	E

ECSS Source Id	Req. Statement	ECSS Object Type	Verification			Inclusive requirements								Exclusive requirements															
			Verification Points (SRR, PDR, etc, see complete list at the end of this table)	Verification Methods (RoD, A, etc see complete list at the end of this table)	Recorded in [1] Electrical ICD (incl. SAR, Battery Antenna) [2] Budget document (e.g. Power, Energy, Processor, and memory budgets) [3] DDF or DJF [4] GDIR [5] Tests Report [6] Specification [7] User Manual [8] EIDP	SSE: Space Segment Element (physical view of Space Segment System)	SSS: Space segment sub-system	SSEq: Space Segment Equipment	LSE: Launch Segment Elements (physical view of Launch Segment System)	LSS: Launch Segment Subsystem	LSEq: Launch Segment Equipment	GSE: Ground Segment Elements (physical view of Ground Segment System)	GSS: Ground Segment Subsystems	GSEq: Ground Segment Equipment	Electrical Ground Support Equipment	Electrical Power Subsystem	Power Conditioning Unit	Power distribution and protection	Solar Array	Solar Array Drive Mechanism/Electronics	Battery	Battery management	Redundant	Switching converter	Generates/Receives telecommand	High Voltage	Single shot device	Circuit for single shot device	Antenna an RF chain
7.2.2.5a	The characterisation of antenna performances shall cover the following parameters. 1Coverage or Beam shape; 2Directivity; 3Electrical boresight or Beam pointing; 4Gain or Beam efficiency; 5Input impedance mismatch factor; 6Radiation pattern; 7Sense of polarization; 8Side lobe level; 9Polarisation purity or Axial ratio; 10Group delay; 11Noise temperature, for receive antennas; 12Phase centre position; 13Variations with frequency, angle (where applicable) and aging of all above parameters.	Requirement	PDR, CDR, QTR, AR	RoD	[3][5]	//	//	//	//	//	//	-	-	-	-	-	-	-	-	-	-	-	-	-	-	-	-	-	E
7.2.3.1a	Connectors or waveguide flanges at the antenna ports shall be demonstrated to have the specified power handling capabilities and impedance mismatch factors.	Requirement	PDR, CDR	A, T, RoD	[3][5][8]	//	//	//	//	//	//	-	-	-	-	-	-	-	-	-	-	-	-	-	-	-	-	-	E
7.2.3.1b	It shall be demonstrated that the generation of passive inter-modulation products that can occur at the antenna ports is below the specified limits agreed with the customer.	Requirement	PDR, CDR, QTR, AR	A, T, RoD	[3], [5], [8]	//	//	//	//	//	//	-	-	-	-	-	-	-	-	-	-	-	-	-	-	-	-	E	
7.2.3.1c	For antenna ports the applicable pressure range and gas properties shall be specified.	Requirement	-	-	-	//	//	//	//	//	//	-	-	-	-	-	-	-	-	-	-	-	-	-	-	-	-	E	
7.2.3.1d	For antenna ports the design and manufacturing shall be performed to avoid discharge phenomena according to Paschen curves valid for its specified pressure range and gas properties.	Requirement	-	-	-	//	//	//	//	//	//	-	-	-	-	-	-	-	-	-	-	-	-	-	-	-	-	E	

ECSS Source Id	Req. Statement	ECSS Object Type	Verification			Inclusive requirements									Exclusive requirements														
			Verification Points (SRR, PDR, etc, see complete list at the end of this table)	Verification Methods (RoD, A, etc see complete list at the end of this table)	Recorded in [1] Electrical ICD (incl. SAR, Battery Antenna) [2] Budget document (e.g. Power, Energy, Processor, and memory budgets) [3] DDF or DJF [4] GDIR [5] Tests Report [6] Specification [7] User Manual [8] EIDP	SSE: Space Segment Element (physical view of Space Segment System)	SSS: Space segment sub-system	SSEq: Space Segment Equipment	LSE: Launch Segment Elements (physical view of Launch Segment System)	LSS: Launch Segment Subsystem	LSEq: Launch Segment Equipment	GSE: Ground Segment Elements (physical view of Ground Segment System)	GSS: Ground Segment Subsystems	GSEq: Ground Segment Equipment	Electrical Ground Support Equipment	Electrical Power Subsystem	Power Conditioning Unit	Power distribution and protection	Solar Array	Solar Array Drive Mechanism/Electronics	Battery	Battery management	Redundant	Switching converter	Generates/Receives telecommand	High Voltage	Single shot device	Circuit for single shot device	Antenna an RF chain
7.2.3.2a	Electromagnetic interactions among the antenna and the surrounding spacecraft structure and appendages shall be quantified starting from Phase B, as a minimum, and their impact on antenna performances assessed.	Requirement	PDR, CDR	A, T	[3][5]	//	//	//	//	//	//	-	-	-	-	-	-	-	-	-	-	-	-	-	-	-	-	-	E
7.2.3.2b	For all high-power applications, the risk of generation of passive inter-modulation products by the surrounding spacecraft structure and appendages shall be assessed starting from Phase B, as a minimum, and the impact on antenna performances assessed.	Requirement	PDR	A	[3]	//	//	//	//	//	//	-	-	-	-	-	-	-	-	-	-	-	-	-	-	-	-	-	E
7.2.4a	The requirements of this clause 7.2 shall be verified by the verification methods, at the reviews, and recorded in the documents as specified in Table 8-3.	Recommendation	-	-	-	//	//	//	//	//	//	-	-	-	-	-	-	-	-	-	-	-	-	-	-	-	-	-	E
7.3.2.1a	All the components and equipments of the RF chain shall be able to stand the maximum specified operating RF power during its application in space with: 1no degradation of the component, 2no degradation of the RF signal including radiative losses, and 3with their thermal levels not exceeding those corresponding to the maximum available RF power at the maximum qualification temperature.	Requirement	TRB	1. INS 2. T 3. T	[8]	//	//	//	//	//	//	-	-	-	-	-	-	-	-	-	-	-	-	-	-	-	-	-	E
7.3.2.2a	Each element of the RF chain shall be designed and verified to withstand the maximum specified operating RF power levels plus safety margins agreed with the customer in the development phase at the maximum qualification temperature.	Requirement	PDR, CDR, TRB	A, T	[8]	//	//	//	//	//	//	-	-	-	-	-	-	-	-	-	-	-	-	-	-	-	-	-	E

ECSS Source Id	Req. Statement	ECSS Object Type	Verification			Inclusive requirements								Exclusive requirements																
			Verification Points (SRR, PDR, etc, see complete list at the end of this table)	Verification Methods (RoD, A, etc see complete list at the end of this table)	Recorded in [1] Electrical ICD (incl. SAR, Battery Antenna) [2] Budget document (e.g. Power, Energy, Processor, and memory budgets) [3] DDF or DJF [4] GDIR [5] Tests Report [6] Specification [7] User Manual [8] EIDP	SSE: Space Segment Element (physical view of Space Segment System)	SSS: Space segment sub-system	SSEq: Space Segment Equipment	LSE: Launch Segment Elements (physical view of Launch Segment System)	LSS: Launch Segment Subsystem	LSEq: Launch Segment Equipment	GSE: Ground Segment Elements (physical view of Ground Segment System)	GSS: Ground Segment Subsystems	GSEq: Ground Segment Equipment	Electrical Ground Support Equipment	Electrical Power Subsystem	Power Conditioning Unit	Power distribution and protection	Solar Array	Solar Array Drive Mechanism/Electronics	Battery	Battery management	Redundant	Switching converter	Generates/Receives telecommand	High Voltage	Single shot device	Circuit for single shot device	Antenna an RF chain	
7.3.3.1a	All the components and equipments of the RF chain shall be free of any risk of Gas discharge (Corona) at the maximum specified operating RF power over the full pressure range during: 1the depressurization of the RF components and equipments at launch environmental conditions, 2the pressurization due to out-gassing of the spacecraft in orbit, 3ground testing at ambient pressure, and 4the pressurization of the spacecraft during planetary re-entry phases at the mission environmental conditions.	Requirement	PDR, CDR, TRB	1. A, T 2. A, T 3. T 4. A, T	1. [1][8] 2. [1][8] 3. [8] 4. [1][8]	>>	>>	//	>>	>>	//	-	-	-	-	-	-	-	-	-	-	-	-	-	-	-	-	-	-	E
7.3.3.1b	For those components and equipments which design does not allow operating them over the full pressure range the following action shall be taken: 1specify the applicable pressure range and gas properties, 2ensure that the design and manufacturing is such to avoid discharge phenomena according to Paschen curves valid for its specified pressure range and gas properties.	Requirement	1. SRR 2. PDR, CDR	RoD	[1]	//	//	//	//	//	//	-	-	-	-	-	-	-	-	-	-	-	-	-	-	-	-	-	-	E
7.3.3.2a	RF components and equipments of the RF chain shall be designed and verified to withstand the maximum specified operating RF power levels plus safety margins agreed with the customer in the development phase.	Requirement	PDR, CDR, TRR, TRB	A, RoD, T	[1][8]	>>	>>	//	>>	>>	//	-	-	-	-	-	-	-	-	-	-	-	-	-	-	-	-	-	E	
7.3.4a	The following criteria shall be met for qualification for power handling and gas discharge: 1the RF component and equipment has no physical degradation, 2the RF component and equipment has no degradation of the RF performance during and after the test.	Requirement	TRB	1. INS 2. T	[8]	>>	>>	//	>>	>>	//	-	-	-	-	-	-	-	-	-	-	-	-	-	-	-	-	-	E	
7.4.2a	The acceptance level of interference caused by passive intermodulation products shall be agreed with the customer in the development phase.	Requirement	SRR, PDR, CDR	RoD	[1]	//	//	//	//	//	//	-	-	-	-	-	-	-	-	-	-	-	-	-	-	-	-	-	E	

ECSS Source Id	Req. Statement	ECSS Object Type	Verification			Inclusive requirements										Exclusive requirements													
			Verification Points (SRR, PDR, etc, see complete list at the end of this table)	Verification Methods (RoD, A, etc see complete list at the end of this table)	Recorded in [1] Electrical ICD (incl. SAR, Battery Antenna) [2] Budget document (e.g. Power, Energy, Processor, and memory budgets) [3] DDF or DJF [4] GDIR [5] Tests Report [6] Specification [7] User Manual [8] EIDP	SSE: Space Segment Element (physical view of Space Segment System)	SSS: Space segment sub-system	SSEq: Space Segment Equipment	LSE: Launch Segment Elements (physical view of Launch Segment System)	LSS: Launch Segment Subsystem	LSEq: Launch Segment Equipment	GSE: Ground Segment Elements (physical view of Ground Segment System)	GSS: Ground Segment Subsystems	GSEq: Ground Segment Equipment	Electrical Ground Support Equipment	Electrical Power Subsystem	Power Conditioning Unit	Power distribution and protection	Solar Array	Solar Array Drive Mechanism/Electronics	Battery	Battery management	Redundant	Switching converter	Generates/Receives telecommand	High Voltage	Single shot device	Circuit for single shot device	Antenna an RF chain
7.4.2b	All the components of the RF chain shall be designed and manufactured to guarantee that the passive intermodulation products derived from the transmit carriers do not cause interference with any of the spacecraft receive bands or third party protected frequency bands during the operating temperature cycles.	Requirement	SRR, PDR, CDR	RoD, A, INS	[1]	//	//	//	//	//	//	-	-	-	-	-	-	-	-	-	-	-	-	-	-	-	-	-	E
7.4.3a	All operating conditions shall be identified in which two or more transmit RF signals simultaneously illuminate or passed through a passive RF component, equipment or both.	Requirement	PDR, CDR, TRR	A, RoD	[1][8]	//	//	//	//	//	//	-	-	-	-	-	-	-	-	-	-	-	-	-	-	-	-	-	E
7.4.3b	For each of the conditions identified in 7.4.3a, the frequencies, number of carriers and power levels of these carriers shall be determined.	Requirement	PDR, CDR, TRR	A, RoD,	[1][8]	//	//	//	//	//	//	-	-	-	-	-	-	-	-	-	-	-	-	-	-	-	-	-	E
7.4.3c	An analysis shall be performed to establish all the passive intermodulation products falling within any of the spacecraft receive bands or third party protected frequency bands, for all combinations of frequency carriers up to the intermodulation order of 100.	Requirement	PDR, CDR, TRR	A, RoD,	[1][8]	//	//	//	//	//	//	-	-	-	-	-	-	-	-	-	-	-	-	-	-	-	-	-	E
7.4.4a	Testing at the lowest intermodulation order as identified in 7.4.3c shall be performed to ensure that the amplitudes of the passive intermodulation products are below the specified interference level.	Requirement	TRR, TRB	T	[8]	//	//	//	//	//	//	-	-	-	-	-	-	-	-	-	-	-	-	-	-	-	-	-	E
7.4.4b	Passive Intermodulation tests shall be carried out on the flight hardware in the same configuration as it is during operational use.	Requirement	TRR, TRB	T	[8]	//	//	//	//	//	//	-	-	-	-	-	-	-	-	-	-	-	-	-	-	-	-	-	E
7.4.4c	The test frequencies, number of carriers and power levels of these carriers shall be those as identified in 7.4.3b.	Requirement	TRR, TRB	T	[8]	//	//	//	//	//	//	-	-	-	-	-	-	-	-	-	-	-	-	-	-	-	-	-	E
7.4.4d	Qualification testing shall be carried out on RF non radiative passive components, or equipments, or systems, over the full qualification temperature range, on RF radiative components, equipments or systems over a temperature range to be agreed with the customer, range which can be limited to ambient temperature.	Requirement	TRR, TRB	T	[8]	//	//	//	//	//	//	-	-	-	-	-	-	-	-	-	-	-	-	-	-	-	-	-	E
7.4.4e	Acceptance testing shall be carried out on flight components, equipments or systems over an acceptance temperature range to be agreed with the customer, range which can be limited to ambient temperature.	Requirement	-	-	-	//	//	//	//	//	//	-	-	-	-	-	-	-	-	-	-	-	-	-	-	-	-	-	E

ECSS Source Id	Req. Statement	ECSS Object Type	Verification			Inclusive requirements										Exclusive requirements													
			Verification Points (SRR, PDR, etc, see complete list at the end of this table)	Verification Methods (RoD, A, etc see complete list at the end of this table)	Recorded in [1] Electrical ICD (incl. SAR, Battery Antenna) [2] Budget document (e.g. Power, Energy, Processor, and memory budgets) [3] DDF or DJF [4] GDIR [5] Tests Report [6] Specification [7] User Manual [8] EIDP	SSE: Space Segment Element (physical view of Space Segment System)	SSS: Space segment sub-system	SSEq: Space Segment Equipment	LSE: Launch Segment Elements (physical view of Launch Segment System)	LSS: Launch Segment Subsystem	LSEq: Launch Segment Equipment	GSE: Ground Segment Elements (physical view of Ground Segment System)	GSS: Ground Segment Subsystems	GSEq: Ground Segment Equipment	Electrical Ground Support Equipment	Electrical Power Subsystem	Power Conditioning Unit	Power distribution and protection	Solar Array	Solar Array Drive Mechanism/Electronics	Battery	Battery management	Redundant	Switching converter	Generates/Receives telecommand	High Voltage	Single shot device	Circuit for single shot device	Antenna an RF chain
7.4.5a	The amplitude of each passive intermodulation product falling within any of the spacecraft receive bands or third party protected frequency bands shall be lower than the level specified in 7.4.2a.	Requirement	TRR, TRB	T	[8]	//	//	//	//	//	//	-	-	-	-	-	-	-	-	-	-	-	-	-	-	-	-	-	E
7.5a	The requirements of the clauses 7.3 and 7.4 should be verified by the verification methods, at the reviews, and recorded in the documentation as specified in Table 8-3.	Recommendation	-	-	-	//	//	//	//	//	//	-	-	-	-	-	-	-	-	-	-	-	-	-	-	-	-	-	E
A.2.1a	The EMC control plan shall contain a description of the purpose, objective, content and the reason of prompting its preparation.	Requirement	-	-	-	X	X	X	X	X	X	-	-	-	-	-	-	-	-	-	-	-	-	-	-	-	-	-	-
A.2.1b	The EMC control plan shall list the applicable and reference documents to support the generation of the document.	Requirement	-	-	-	X	X	X	X	X	X	-	-	-	-	-	-	-	-	-	-	-	-	-	-	-	-	-	-
A.2.1c	The EMC control plan shall include any additional definition, abbreviation or symbol used.	Requirement	-	-	-	X	X	X	X	X	X	-	-	-	-	-	-	-	-	-	-	-	-	-	-	-	-	-	-
A.2.1d	The EMC control plan shall list the EMC requirements to be verified, covering at least the following areas:....	Requirement	-	-	-	X	X	X	X	X	X	-	-	-	-	-	-	-	-	-	-	-	-	-	-	-	-	-	-
B.2.1a	The EMEVP shall contain a description of the purpose, objective, content and the reason of prompting its preparation.	Requirement	-	-	-	X	X	X	X	X	X	-	-	-	-	-	-	-	-	-	-	-	-	-	-	-	-	-	-
B.2.1b	The EMEVP shall list the applicable and reference documents to support the generation of the document.	Requirement	-	-	-	X	X	X	X	X	X	-	-	-	-	-	-	-	-	-	-	-	-	-	-	-	-	-	-
B.2.1c	The EMEVP shall include any additional definition, abbreviation or symbol used.	Requirement	-	-	-	X	X	X	X	X	X	-	-	-	-	-	-	-	-	-	-	-	-	-	-	-	-	-	-

ECSS Source Id	Req. Statement	ECSS Object Type	Verification			Inclusive requirements								Exclusive requirements															
			Verification Points (SRR, PDR, etc, see complete list at the end of this table)	Verification Methods (RoD, A, etc see complete list at the end of this table)	Recorded in [1] Electrical ICD (incl. SAR, Battery Antenna) [2] Budget document (e.g. Power, Energy, Processor, and memory budgets) [3] DDF or DJF [4] GDIR [5] Tests Report [6] Specification [7] User Manual [8] EIDP	SSE: Space Segment Element (physical view of Space Segment System)	SSS: Space segment sub-system	SSEq: Space Segment Equipment	LSE: Launch Segment Elements (physical view of Launch Segment System)	LSS: Launch Segment Subsystem	LSEq: Launch Segment Equipment	GSE: Ground Segment Elements (physical view of Ground Segment System)	GSS: Ground Segment Subsystems	GSEq: Ground Segment Equipment	Electrical Ground Support Equipment	Electrical Power Subsystem	Power Conditioning Unit	Power distribution and protection	Solar Array	Solar Array Drive Mechanism/Electronics	Battery	Battery management	Redundant	Switching converter	Generates/Receives telecommand	High Voltage	Single shot device	Circuit for single shot device	Antenna an RF chain
D.2.1a	The battery user manual shall contain the following information: 1. maximum ground storage life (where applicable before and after activation); 2. maximum period of non-use without special "wake-up" cycling; 3. range of battery temperatures and maximum durations during pre-launch and operational phases; 4. battery maintenance procedures during integration and pre-launch phases including case of launch delay; 5. storage procedure, range of storage temperature, cell discharge requirements before storage; 6. humidity and packaging constraints for storage; 7. maximum and minimum state of charge to be maintained during storage, requirements on individual shorting of cells, details of any trickle charge or periodic maintenance (e.g. minimum voltage checks and top-up charge to a maximum voltage in case a minimum cell voltage is reached) 8. reactivation procedure after storage; 9. handling and cell connecting procedures and precautions; 10. cell and battery safety related information; 11. transportation requirements.	Requirement	-	-	-	>>	>>	//	>>	>>	//	-	-	-	-	-	-	-	-	E	-	-	-	-	-	-	-	-	-

ECSS Source Id	Req. Statement	ECSS Object Type	Verification		Inclusive requirements								Exclusive requirements																
			Verification Points (SRR, PDR, etc, see complete list at the end of this table)	Verification Methods (RoD, A, etc see complete list at the end of this table)	Recorded in [1] Electrical ICD (incl. SAR, Battery Antenna) [2] Budget document (e.g. Power, Energy, Processor, and memory budgets) [3] DDF or DJF [4] GDIR [5] Tests Report [6] Specification [7] User Manual [8] EIDP	SSE: Space Segment Element (physical view of Space Segment System)	SSS: Space segment sub-system	SSEq: Space Segment Equipment	LSE: Launch Segment Elements (physical view of Launch Segment System)	LSS: Launch Segment Subsystem	LSEq: Launch Segment Equipment	GSE: Ground Segment Elements (physical view of Ground Segment System)	GSS: Ground Segment Subsystems	GSEq: Ground Segment Equipment	Electrical Ground Support Equipment	Electrical Power Subsystem	Power Conditioning Unit	Power distribution and protection	Solar Array	Solar Array Drive Mechanism/Electronics	Battery	Battery management	Redundant	Switching converter	Generates/Receives telecommand	High Voltage	Single shot device	Circuit for single shot device	Antenna an RF chain
<p>Verification points:</p> <ul style="list-style-type: none"> SRR: System requirements review PDR: Preliminary design review CDR: Critical design review TRR: Test readiness review TRB: Test review board DRB: Delivery review board AR: Acceptance review <p>Verification methods:</p> <ul style="list-style-type: none"> RoD: Review of design T: Test A: Analysis INS: Inspection NOTES: RoD includes review of documentation 																													

Annex A (normative)

EMC control plan - DRD

A.1 DRD identification

A.1.1 Requirement identification and source document

This DRD is called from ECSS-E-ST-20, requirement 6.2.2a.

A.1.2 Purpose and objective

The EMC control plan defines the approach, methods, procedures, resources and organization to design, produce and verify a product to operate within its specified electromagnetic environment and performance characteristics.

It provides the instruction for conducting all activities related to the management, the design requirements and the verification of the electromagnetic compatibility of all items of equipment and subsystems of a project.

A.2 Expected response

A.2.1 Scope and content

ECSS-E-ST-20_0020365

- a. The EMC control plan shall contain a description of the purpose, objective, content and the reason of prompting its preparation.

ECSS-E-ST-20_0020366

- b. The EMC control plan shall list the applicable and reference documents to support the generation of the document.

ECSS-E-ST-20_0020367

- c. The EMC control plan shall include any additional definition, abbreviation or symbol used.

- d. The EMC control plan shall list the EMC requirements to be verified, covering at least the following areas:
1. The EMC programme management:
 - (a) responsibilities of customer and supplier at all levels, lines and protocols of communication, control of design changes;
 - (b) planning of the EMC control program: facilities and personnel required for successful implementation of the EMC control program; methods and procedures of accomplishing EMC design reviews and coordination;
 - (c) programme schedules: Integration of EMC program schedule and milestones within the program development master schedule.
 2. System level performance and design requirements:
 - (a) definition of electromagnetic and related environments;
 - (b) definition of critical circuits;
 - (c) allocation of design responses at system and subsystem and equipment levels;
 - (d) antenna-to-antenna interference reduction analysis and technique;
 - (e) magnetic moment upper limit required for AOCS;
 - (f) magnetic cleanliness control plan (spacecraft with specific payloads);
 - (g) magnetic budget;
 - (h) establishment of a controlled grounding scheme;
 - (i) assessment of possible fault currents;
 - (j) wiring (including shielding and shield termination and categorization) practises;
 - (k) electrical bonding;
 - (l) material properties, effects of corrosion prevention and similar concerns on bonding and general EMC issues;
 - (m) design criteria for alleviating effects of spacecraft charging and other electrification issues.
 3. Subsystem and equipment EMI performance requirements and verification:
 - (a) allocated EMI performance at the equipment level, including tailored equipment level requirements. The control plan is the vehicle for tailoring limits and test methods;
 - (1) Conducted emission on power leads in the frequency domain
 - (2) Inrush current **peak(s) and profile** on power leads

- (3) Common mode conducted emission on power and signal leads
 - (4) Conducted emission on antenna ports
 - (5) DC magnetic field emission
 - (6) Radiated magnetic field emission in the low frequency range (scientific spacecraft)
 - (7) Radiated electric field emission in the low frequency range (scientific spacecraft)
 - (8) Radiated emission of RF electric field
 - (9) Conducted susceptibility on power leads in differential mode
 - (10) Conducted susceptibility on power and signal leads in common mode
 - (11) Conducted susceptibility to transients on power leads
 - (12) Radiated susceptibility to low frequency magnetic fields
 - (13) Radiated susceptibility to RF electric fields
 - (14) Susceptibility to electrostatic discharges
- (b) Summary of test results from subsystem and equipment level EMI tests. Any specification non-compliances judged to be acceptable is described in detail and the justifying rationale presented.
4. Electro-Explosive Devices (EED):
- (a) appropriate requirements (ECSS-E-ST-33-11 and ECSS-E-ST-20-07);
 - (b) design techniques;
 - (c) verification.
5. EMC analysis:
- (a) predictions of intra-system EMI and EMC based on expected or actual equipment and subsystem EMI characteristics;
 - (b) design of solutions for predicted or actual interference situations;
6. Spacecraft level EMC verification, including outline of system-level EMC test plan, including rationale for selection of critical circuits for safety margin demonstration and instrumentation techniques for both critical and EED circuit sensitisation.

A.2.2 Special remarks

None.

Annex B (normative)

Electromagnetic effects verification plan (EMEVP) - DRD

B.1 DRD identification

B.1.1 Requirement identification and source document

This DRD is called from ECSS-E-ST-20, requirement 6.4.1b.

B.1.2 Purpose and objective

The electromagnetic effects verification plan (EMEVP) defines the approach, methods, procedures to verify electromagnetic effects.

The EMEVP provides the instruction for conducting all activities required to verify that the effects of the electromagnetic environment are compatible with the requirements of the project.

B.2 Expected response

B.2.1 Scope and content

- ECSS-E-ST-20_0020369

a. The EMEVP shall contain a description of the purpose, objective, content and the reason of prompting its preparation.
- ECSS-E-ST-20_0020370

b. The EMEVP shall list the applicable and reference documents to support the generation of the document.
- ECSS-E-ST-20_0020371

c. The EMEVP shall include any additional definition, abbreviation or symbol used.
- ECSS-E-ST-20_0020372

d. The EMEVP shall list the requirements of the plan, including:
 - 1. methods to be used to select critical circuits, used to monitor conformance to degradation criteria and safety margins, including the definition of the method of selection;
 - 2. procedures used for developing failure criteria and limits;

3. test conditions and procedures for all electronic and electrical equipment installed in or associated with spacecraft and sequence for operations during tests, including switching;
4. specific tolerance for particular measurement;
5. implementation and application of test procedures, including modes of operation and monitoring points for each subsystem or equipment;
6. use of approved results from laboratory interference tests on subsystems and equipment;
7. methods and procedures for data readout and analysis;
8. means of verifying design adequacy of spacecraft electrification;
9. means of simulating and testing electro-explosive subsystems and devices (EEDs);
10. verifying electrical power quality, and methods for monitoring DC and AC power busses;
11. test locations and descriptions of arrangements for simulating operational performance in cases where actual operation is impractical;
12. configuration of equipment and subsystems modes of operation to ensure victim equipment and subsystems are tested in most sensitive modes, while culprit equipment and subsystems are tested in noisiest mode(s);
13. details concerning frequency ranges, channels, and combinations to be specifically tested such as image frequencies, intermediate frequencies, local oscillator, transmitter fundamental and harmonically related frequencies, and including subsystem susceptibility frequencies identified during laboratory testing;
14. to precise parallel or series injection for conducted susceptibility test;
15. personnel to perform the test, including customer and supplier personnel at all levels, and quality representatives;
16. list of all test equipment to use, including a description of unique EMC instrumentation for stimulating and measuring electrical, electronic, and mechanical outputs of equipment and subsystems to be monitored during the test programme;
17. description of cables attached to the equipment under test;
18. definition of the line impedance stabilization network (values of internal components);
19. need for calibration and check of the measurement setup;
20. antennas to use for RF emission and susceptibility tests;
21. Method of switching ON for inrush current testing.

NOTE to item 4 “specific tolerance for particular measurement”: See also B.2.1e. and f.

ECSS-E-ST-20_0020373

- e. An intra-system compatibility culprit/victim test matrix shall be included in the EMEVP, showing all combinations of individual equipment/subsystems to be tested in order to verify overall intra-system compatibility;

ECSS-E-ST-20_0020374

- f. The description of the Step-by-step test procedures for operation of all matrix equipment shall be included in the EMEVP to support test execution.

B.2.2 Special remarks

None.

Annex C (normative)

Electromagnetic effects verification report (EMEVR) - DRD

C.1 DRD identification

C.1.1 Requirement identification and source document

This DRD is called from ECSS-E-ST-20, requirement 6.4.1c.

C.1.2 Purpose and objective

The electromagnetic effects verification report (EMEVR) provides reporting of all activities in relation with the verification of the effects of the electromagnetic environment.

The document is prepared for each project, based on the electromagnetic effects verification plan.

It then applies to every item of equipment and subsystem in the project.

C.2 Expected response

C.2.1 Scope and content

ECSS-E-ST-20_0020375

- a. The EMEVR shall contain a description of the purpose, objective, content and the reason of prompting its preparation.

ECSS-E-ST-20_0020376

- b. The EMEVR shall list the applicable and reference documents to support the generation of the document.

ECSS-E-ST-20_0020377

- c. The EMEVR shall include any additional definition, abbreviation or symbol used.

ECSS-E-ST-20_0020378

- d. The EMEVR shall include:
1. identification of specific objectives, including applicable requirements and EMEVP references;

2. description of test article (e.g. configuration and drawings and photographs);
3. description of any fixes or configuration changes to article resulting from verification failures;
4. description of changes to cables attached to the equipment under test with respect to the EMEVP
5. summary of results including an executive summary stating degree of conformance to requirements;
6. description of any deviations from test facilities, analysis techniques or tools, and inspection aids in EMEVP;
7. description of any deviations from step-by-step procedures in EMEVP;
8. test set-up diagrams/photographs as appropriate;
9. list of test equipment, including calibration information;
10. recorded data or logs, including instrument readings, correction factors, and reduced results; methods of data reduction.
11. If value of data has been compromised due to test conditions, the reason and impact on results;
12. description of ambient and other test conditions.

C.2.2 Special remarks

None.

Annex D (normative)

Battery user manual - DRD

D.1 DRD identification

D.1.1 Requirement identification and source document

This DRD is called from ECSS-E-ST-20, requirement 5.6.4b.

D.1.2 Purpose and objective

The battery user manual is a document generated by the manufacturer, that can be used by the customer for the procurement of cells and batteries.

D.2 Expected response

D.2.1 Scope and content

ECSS-E-ST-20_0020379

- a. The battery user manual shall contain the following information:
1. maximum ground storage life (where applicable before and after activation);
 2. maximum period of non-use without special “wake-up” cycling;
 3. range of battery temperatures and maximum durations during pre-launch and operational phases;
 4. battery maintenance procedures during integration and pre-launch phases including case of launch delay;
 5. storage procedure, range of storage temperature, cell discharge requirements before storage;
 6. humidity and packaging constraints for storage;
 7. maximum and minimum state of charge to be maintained during storage, requirements on individual shorting of cells, details of any trickle charge or periodic maintenance (e.g. minimum voltage checks and top-up charge to a maximum voltage in case a minimum cell voltage is reached)
 8. reactivation procedure after storage;
 9. handling and cell connecting procedures and precautions;
 10. cell and battery safety related information;
 11. transportation requirements.

D.2.2 Special remarks

None.

Bibliography

ECSS-S-ST-00	ECSS system – Description, implementation and general requirements
ECSS-E-ST-10-02	Space engineering – Verification
ECSS-E-ST-10-04	Space engineering – Space environment
ECSS-E-ST-20-01	Space engineering – Multipaction design and test
ECSS-E-ST-20-08	Space engineering – Photovoltaic assemblies and components
ECSS-E-ST-20-20	Space engineering – Electrical design and interface requirements for power supply
ECSS-E-ST-32	Space engineering – Structural general requirements
ECSS-E-HB-20-02	Space engineering – Li-ion battery testing handbook
ECSS-E-HB-20-05	Space engineering – High voltage engineering and design handbook
ECSS-E-HB-20-20	Space engineering – Guidelines for electrical design and interface requirements for power supply
ECSS-Q-ST-30	Space product assurance – Dependability
ECSS-Q-ST-40	Space product assurance – Safety
ECSS-Q-ST-70	Space product assurance – Materials, mechanical parts and processes
ECSS-U-AS-10	Adoption Notice of ISO 24113: Space systems - Space debris mitigation requirements
NASA-STD-8739.4	Crimping, interconnecting cables, harnesses, and wiring
RNC-CNES-Q-70-511	Spécification de conception et de contrôle des interconnexions filaires
JSC-20793 Rev B April 06	Crew vehicle battery safety requirements