



European Cooperation for  
Space Standardization

# Electrical Engineering, ECSS E-20 series

Presented by

**FERDINANDO TONICELLO, ELECTRICAL LEAD ENGINEER**

TEC-E, ESA-ESTEC

# Electrical Engineering: ECSS E 20 series

## SCOPE

- Understanding of key requirements
- Develop a better familiarity with ECSS E20 series
- Better capability to interface with ESA on electrical matters
- Better capability to evaluate deviations and waivers with proper knowledge of underlying rationale

# Where to find our standards?

## ECSS Standards Engineering branch

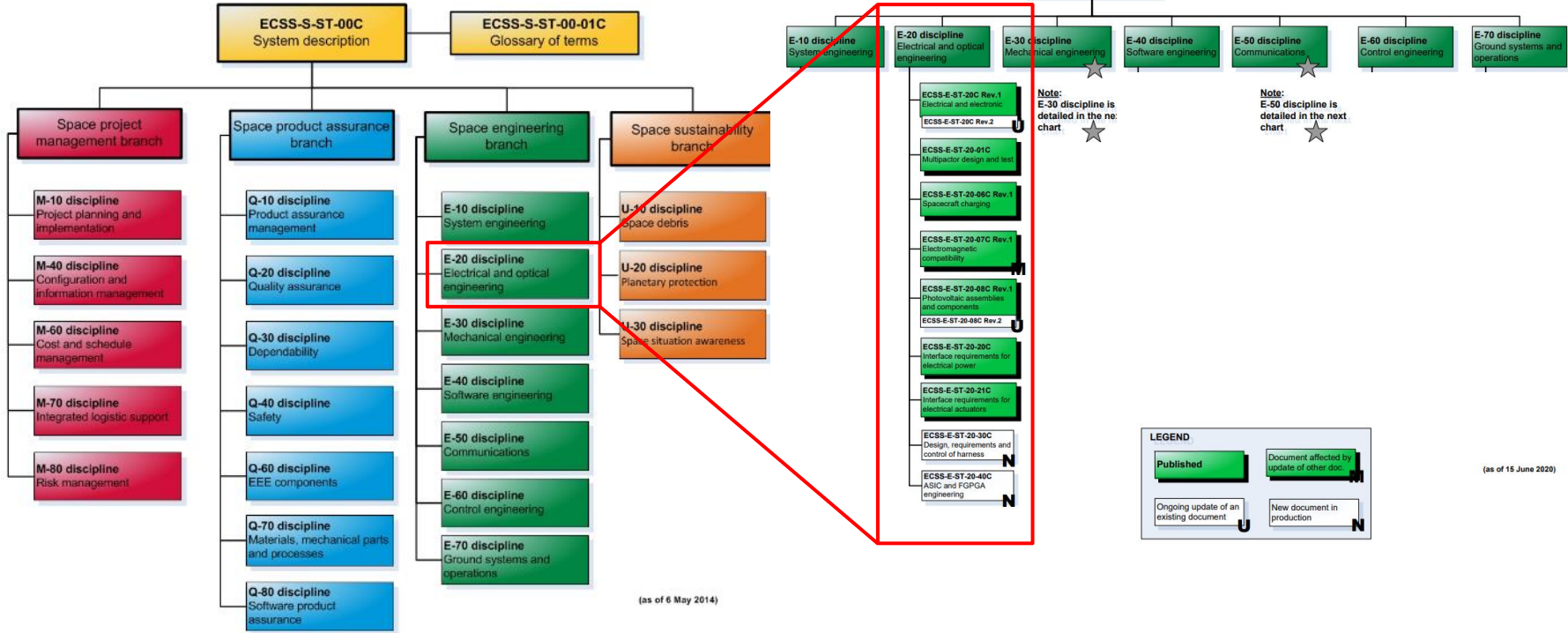

# How to find our handbooks?

ECSS Handbooks and Technical memoranda  
Engineering branch HBs and TMs

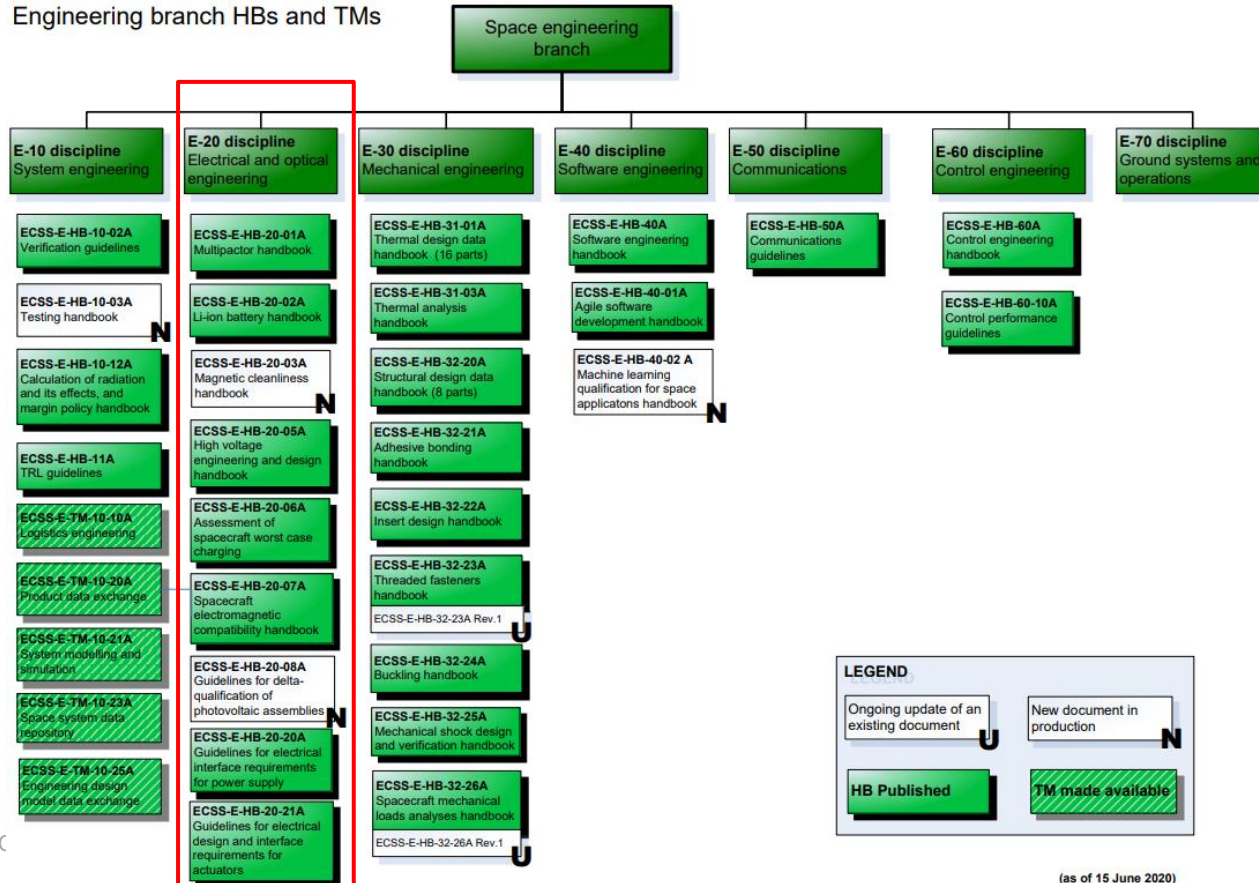

# ECSS E 20 series, tutorial

- Coverage
  - ECSS-E-ST-20C Rev. 2, [Electrical and electronic](#), in this presentation called “STD”
  - E-ST-20-20C (E-HB-20-20A), [Electrical design and interface req.’s for power supply](#)
  - ECSS-E-ST-20-06C, Rev. 1, [Spacecraft Charging](#)
  - ECSS-E-ST-20-07C, Rev.1, [Electromagnetic Compatibility](#)
  - ECSS E-ST-20-08C Rev. 1, [Photovoltaic Assemblies and Components](#)
  - ECSS E-ST-20-01A (Multipaction design and test) is not covered, dealing it with RF issues

## STANDARDS:

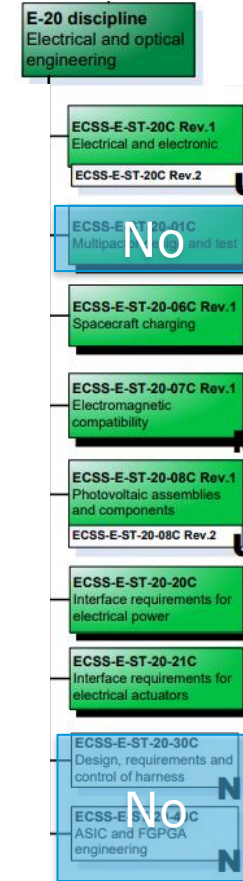

## HANDBOOKS:

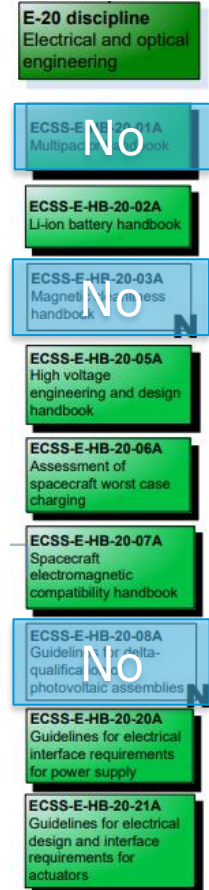

# **ECSS-E-ST-20C Rev.2, Electrical and electronic**

TEC-EP

ESA-ESTEC  
rev1.2

# ECSS E ST 20C, introduction

- Brief history

From the PSS-02-10 to the ECSS-E -ST-20C

1992: Power Standard and Rationale for the Power Standard  
ESA PSS-02-10 Vol 1 and 2

1999: ECSS Standard, Electrical and Electronic  
ECSS-E-20A

2008: ECSS Standard, Electrical and Electronic  
ECSS-E-ST-20C

2019: ECSS Standard, Electrical and Electronic  
ECSS-E-ST-20C Rev.1

2022: ECSS Standard, Electrical and Electronic  
ECSS-E-ST-20C Rev.2 => inclusion of Reliable Insulation requirements chapter

- General remarks:
  - > Strong heritage from Power domain
  - > These documents include a large number of lessons learnt of previous projects

# ECSS E ST 20C, Electrical and electronic, table of contents

- Electronics and power subsystem, key principles
  - Electronics for space
  - Space power subsystem
- Key categories of requirements
  - Reliability
  - Functionality
  - Performance
- Why/when/how to use the STD
- Presentation of the main chapters
- Key STD Definitions
- Key STD requirements
- Conclusions



# ECSS E ST 20C, Electrical and electronic, table of contents

- Electronics and power subsystem, key principles
  - Electronics for space
  - Space power subsystem
- Key categories of requirements
  - Reliability
  - Functionality
  - Performance
- Why/when/how to use the STD
- Presentation of the main chapters
- Key STD Definitions
- Key STD requirements
- Conclusions

# ECSS E ST 20C, Electronics and power subsystem, key principles

- Electronics for space
  - Peculiarities! = > comparison with terrestrial electronics
  - Additional peculiarity for power subsystem

# ECSS E ST 20C, Electronics for space and for terrestrial purposes

	Space application	Terrestrial application
<b>Radiation</b>	<p>Total Dose Irradiation and Single Event Effects are key drivers.</p> <p>Radiation hardened or at least radiation tolerant components shall be used.</p>	<p>Total dose irradiation is negligible and Single Event Effects are rare due to the screen by the Earth atmosphere</p>
<b>Thermal dissipation</b>	<p>Conduction/radiation only.</p> <p>A component running at 40°C in a terrestrial environment might produce case temperatures exceeding 200°C in vacuum.</p>	<p>Convection / forced air is commonly used to keep electronic components under acceptable temperatures</p>
<b>Lifetime</b>	<p>Typically, very extended (up to 18 years operation in telecom satellites)</p>	<p>Typically limited (few years design goal)</p>
<b>Reliability/failure tolerance</b>	<p>Generally, no repair capability during lifetime</p> <p>Important de-rating needs (ECSS-Q-30-11C)</p>	<p>Generally repair is easily feasible: change parts, components</p>
<b>Main design drivers for power electronics</b>	<p>Design mainly driven by reliability and performances (efficiency, mass, volume)</p>	<p>Main driver are usually cost and compactness</p>

# ECSS E ST 20C, Electrical Power Sub-System(EPS)

## Power Generation

- Provide the power required by the spacecraft from launch until the mission completion
- Usually a solar array for near sun satellite applications, sometimes a Radio-Isotope Thermoelectric generator (RTG) for spacecrafts that have to operate at great distances from the sun

## Energy Storage

- Store energy during sunlight
- Ensure a continuous source of electrical power during eclipses
- Complement the power source as needed (e.g. peak power demands, manoeuvres)

## Power Conditioning

- Provide autonomous control of the power generation and energy storage
- Condition the power bus to a defined voltage range
- Provide command and telemetry capability for health check and control

## Power Distribution

- Distribute the power to all the spacecraft loads
- Provide load switching capabilities
- Protect the power lines to avoid failure propagation between loads and EPS

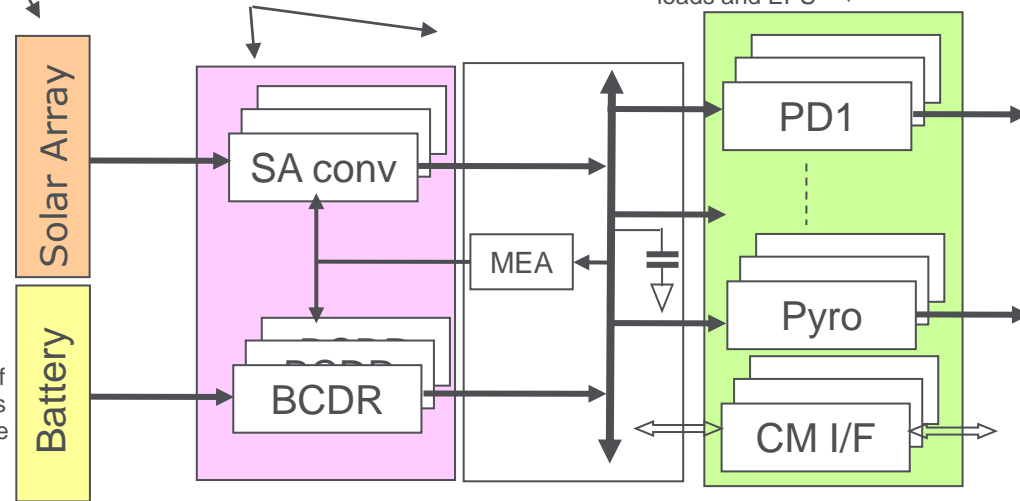

# ECSS E ST 20C, Electrical Power Sub-System, peculiarities

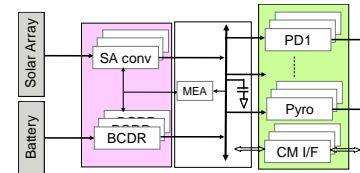

## Failure tolerance

- Once launched, (usually) **no repair** is possible
- The rule:  
*"No single component failure shall result in a significant loss of spacecraft operation."*  
has a very important consequence for the **redundancy, reliability** and **performance** aspects of the power-system design.
- A controlled reduction of power capability might be allowed after a Single Point Failure (e.g. loss of one SA section) or a full **Single Point Failure Free (SPFF)** approach can be required.
  - for manned missions this requirement is enlarged such that double failures shall be tolerated without impacting the safety of astronauts.
- **Modular concepts** are introduced (hot or cold redundancy schemes)
  - Separation of critical sub-circuits (both mechanically and electrically)
  - Redundant connectors on critical lines
- Additional features incorporated in each module to **avoid failure propagation** due to short circuits, over current, over voltage conditions.

## Autonomy

- The power system shall **not** be controlled by an "intelligence" whose circuits are supplied by the power system itself

# ECSS E ST 20C, Electrical and electronic, table of contents

- Electronics and power subsystem, key principles
  - Electronics for space
  - Space power subsystem
- Key categories of requirements
  - Reliability
  - Functionality
  - Performance
- Why/when/how to use the STD
- Presentation of the main chapters
- Key STD Definitions
- Key STD requirements
- Conclusions

# ECSS E ST 20C, key categories of requirements

- **Reliability**
  - In broad sense...
  - Capability of equipment/subsystem/system to fulfil the required function after failures
  - “Failure” management
  - Management of redundancies and protections

# ECSS E ST 20C, key categories of requirements

- **Reliability**

- In broad sense...
- Capability of equipment/subsystem/system to fulfil the required function after failures
- “Failure” management
- Management of redundancies and protections

Example...

STD req.4.2.1.w:

***“The spacecraft electrical system shall be single failure tolerant for unmanned mission and double failure tolerant for manned mission.”***



# ECSS E ST 20C, key categories of requirements

- **Functionality**
  - Capability of equipment/subsystem/system to fulfil or serve the purposes for which it was designed, through design, manufacturing and verification phases

# ECSS E ST 20C, key categories of requirements

- **Functionality**
  - Capability of equipment/subsystem/system to fulfil or serve the purposes for which it was designed, through design, manufacturing and verification phases

Example...

STD req.4.1.3.b:

***"All executable commands shall be explicitly acknowledged by telemetry."***

# ECSS E ST 20C, key categories of requirements

- **Performance**
  - Capability of equipment/subsystem/system to meet the specified scientific or engineering target, through design, manufacturing and verification phases

# ECSS E ST 20C, key categories of requirements

- **Performance**

- Capability of equipment/subsystem/system to meet the specified scientific or engineering target, through design, manufacturing and verification phases

Example...

STD req.5.7.2.i:

***"With a fully regulated bus in nominal operation the bus voltage transients shall:***

***1. for load transients of up to 50% of the nominal load not exceed 1% of its nominal value.***

***2. for any source and load transients remain within 5% of its nominal value."***

# ECSS E ST 20C, key categories of requirements

Why is that important to classify requirements according to

**Reliability**

**Functionality**

**Performance?**

The reason is that requirements on

- **Reliability** requirements are hidden design drivers, and their verification might be easily overlooked!
- **Functionality** might cover non obvious features of the equipment/subsystem/system, and it might also be easy that proper verification is overlooked
- **Performance** dictate the necessary engineering/scientific targets for mission success... but their verification can hardly be forgotten

# ECSS E ST 20C, key categories for requirements, exercise

Identify in the STD

- One requirement on **reliability**
- One requirement on **functionality**
- One requirement on **performance**

=> Discussion

# ECSS E ST 20C, Electrical and electronic, table of contents

- Electronics and power subsystem, key principles
  - Electronics for space
  - Space power subsystem
- Key categories of requirements
  - Reliability
  - Functionality
  - Performance
- Why/when/how to use the STD
- Presentation of the main chapters
- Key STD Definitions
- Key STD requirements
- Conclusions

# ECSS E ST 20C, why/when/how to use the STD

## In general...

### Why?

- Maybe it is a repetition, but it may be worth doing it ... the STD shall be applied **to enhance the chances of success** (e.g. to meet the specific performance, functionality and reliability targets of your electronic units and power subsystem).

### When?

- The application of STD within ESA is indeed recommended **at the beginning of a satellite development** if a classical, top down approach is used to determine system requirements from mission ones, and subsystem/unit level requirements from higher level ones
- In case of subsystem/unit level “stand alone” R&D development the STD application is recommended **at the very beginning of the R&D development** itself (e.g. when TRL level is still low – below 4 or 5) because many of the requirements thereby contained are design drivers
- In case of off-the-shelf subsystem/unit level procurement, the STD application is recommended at the **negotiation phase**.



# ECSS E ST 20C, why/when/how to use the STD

## In general...

## When (continued)?

- d. Do not forget that the STD may become useful in case of disputes with large system integrators and sub-contractors at any time, especially when critical deviations and non conformances appear as a result of HW test!

... keep it in your drawer...

## How?

- A **compliance matrix** shall be produced to identify compliance status to each requirement, with **specific justification for any partial or non compliance**.

# ECSS E ST 20C, why / when / how to use the STD

In particular...

... in the STD each requirement is specified **when**, **how**, and **where** it shall be verified (with reference to satellite classical procurement approach)

-> Example p104 of the ECSS E ST 20C Rev.2:

Table 8-3: Pre-tailoring matrix per "Space product and feature types"

ECSS Source Id	Req. Statement	ECSS Object Type	Verification		
			Verification Points (SRR, PDR, etc. see tables at the end of Clauses)	Verification Methods (RoD, A, etc see tables at the end of each chapter)	Recorded in [1] Electrical ICD (incl. SAR, Battery Antenna) [2] Budget document (e.g. Power, Energy, Processor, and memory budgets) [3] DDF or DJF [4] GDIR [5] Tests Report [6] Specification [7] User Manual [8] EIDP
5.2.1a	Budgets and margins shall be established during Project phase B, and reviewed in all subsequent phases of the project.	Requirement	PDR	RoD	[2]
5.2.2.1a	The power subsystem of a spacecraft shall be able to generate, store, condition, distribute and monitor the electrical power used by the spacecraft throughout all mission phases in the presence of all environments actually encountered.	Requirement	SRR	RoD, A, T	[3][5]
5.2.2.2a	An analysis of power demand versus power available shall be performed, including average peak power, for all phases of the mission.	Requirement	PDR	RoD, A	[2][3]

# ECSS E ST 20C, Electrical and electronic, table of contents

- Electronics and power subsystem, key principles
  - Electronics for space
  - Space power subsystem
- Key categories of requirements
  - Reliability
  - Functionality
  - Performance
- Why/when/how to use the STD
- Presentation of the main chapters
- Key STD Definitions
- Key STD requirements
- Conclusions

# ECSS E ST 20C, presentation of the main chapters

NB not covered by this level 2 course



**Chapter 7**  
Radio Frequency Systems

EMC generic requirements are covered in this chapter. However, EMC specific requirements are covered in the EMC standard ECSS-E-ST-20-07C, Electromagnetic Compatibility



**Chapter 6**  
EMC

**Chapter 2**  
Normative references

**E-ST-20C**  
Electrical and Electronic

**Chapter 5**  
Electrical Power

**Chapter 3**  
Terms, definitions and abbreviated terms

**Chapter 4**  
General requirements

**Chapter 2**  
Normative references

**E-ST-20C**  
Electrical and  
Electronic

**Chapter 3**  
Terms, definitions and  
abbreviated terms

- **Definitions used in the requirements**
- **Abbreviated terms commonly used during meetings and documents**

**Chapter 7**  
Radio Frequency  
Systems

- **Antennas**
- **RF Power**
- **Passive Inter-modulation**

**Chapter 4**  
General requirements

- **Electrical Interfaces**
- **Generic Electrical Design**

**Chapter 6**  
EMC

- **EMC Requirements in term of design**
- **System / equipment requirements**
  - **Spacecraft requirements**

**Chapter 5**  
Electrical  
Power

- **Power subsystem / Budgets**
- **Failure containment / redundancy**
- **Electrical Power Interfaces**
- **Energy generation / Energy Storage**
- **Power Conditioning / Control / Distribution / Protection**

# ECSS E ST 20C, Electrical and electronic, table of contents

- Electronics and power subsystem, key principles
  - Electronics for space
  - Space power subsystem
- Key categories of requirements
  - Reliability
  - Functionality
  - Performance
- Why/when/how to use the STD
- Presentation of the main chapters
- **Key STD Definitions**
- Key STD requirements
- Conclusions

# ECSS E ST 20C, key definitions

- Only some key definitions are hereby explained, they have been chosen according to specific issues making them that special...
  - depth of discharge (DoD)
  - reliable insulation
  - essential function
  - high priority telecommand
  - high voltage
  - single point failure free

# ECSS E ST 20C, DoD definition (1/2)

## Depth of Discharge (or DoD, 3.2.14)

- refers to battery technology.
- it is defined as

*ampere-hour removed from a battery expressed as a percentage of the **nameplate capacity***

- nameplate capacity is in turn defined (3.2.37) as

*capacity stated by the manufacturer of an energy storage cell or battery, given in ampere-hours*

It is not necessarily equal to any measurable capacity.



# ECSS E ST 20C, DoD definition (2/2)

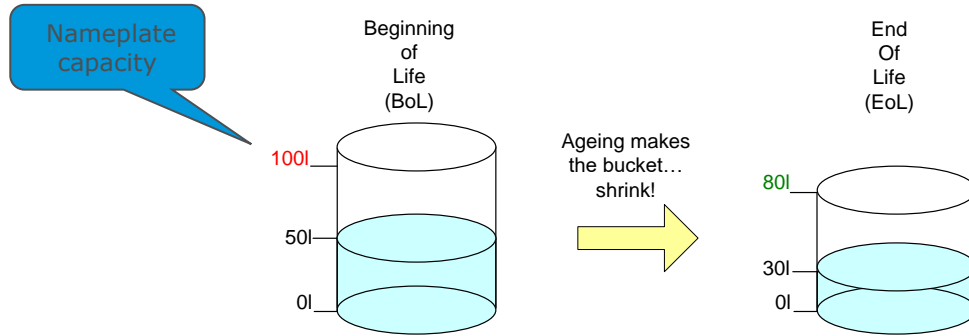

$$\text{DoD} = (100\text{l} - 50\text{l}) / 100\text{l} = 50\%$$

$$\text{DoD} = (80\text{l} - 30\text{l}) / 100\text{l} = 50\%$$

... but the % of actually removed volume is

$$(80\text{l} - 30\text{l}) / 80\text{l} = 62.5\% \text{ !!}$$

## Be careful to

- use DoD properly !!!
- ensure that your interlocutor (Prime, power system or battery manufacturer, etc) understands it and possibly uses the same DoD definition to avoid misunderstandings

# ECSS E ST 20C, RI definition (1/3)

## Reliable Insulation (3.2.47)

- It refers to electrical/electronic items.
- It is defined as

*barrier between conductors or elements of an electronic circuit such that after any credible single failure, conductors or elements of an electronic circuit are still insulated from each other*

- To be read in conjunction with these two additional definitions:

### **Critical net (3.2.11)**

*electrical net that if short circuited with another electrical net or another conductor including satellite and launcher structure can cause critical effects*

### **Critical line (3.2.10)**

*line that is part of a critical net*

# ECSS E ST 20C, RI definition (2/3)

- Repeat of the main RI definition:
  - *"barrier between conductors or elements of an electronic circuit such that **after any credible single failure**, conductors or elements of an electronic circuit are still insulated from each other"*
- *Importance of identifying the credible single failure!*
- *Risk = Severity\* Probability*
- *Dependent on technology, interface, manufacturing, handling (or mishandling), operator's mistakes and accidents, cleanliness...*

# ECSS E ST 20C, RI definition (3/3)

- Applicability of Reliable Insulation (RI) requirements
  - to prevent **single** insulation failures\* that may generate or propagate anomalies with critical consequences (catastrophic or anyhow unacceptable consequences) at mission level.
  - Not only **flight** equipment, but also ground support equipment to exclude dramatic effects of single insulation failures affecting flight hardware (through connection interfaces)
- RI is a overhead...
  - it shall be applied only when and where it is needed... on “critical lines” and “critical nets” of course
- RI is specified in a number of requirements in chapter 4.2.1.2

\* SPFF (Single Point Failure Free) approach generally applies

# ECSS E ST 20C, essential function definition (1/2)

## Essential Function (3.2.24)

- refers generally to electrical/electronic items, but it could be extended to other items
- it is defined as

*function without which the spacecraft cannot be recovered following any conceivable on-board or ground-based failure*

# ECSS E ST 20C, essential function definition (2/2)

## Essential Function (3.2.24)

- Which are essential functions in the terms expressed by the STD?
  - easily identifiable if the “function” **corresponds** to a unit: *satellite receivers, transmitters, OBDH, battery, etc*
  - less obvious when the “function” is **internal** to a unit:  
*Solar Array Regulator (SAR), Battery Charge and Discharge Regulators (BCR, BDR), Main Error Amplifier in the PCDU, but also Reconfiguration Module or Decoder in CDMU.*

# ECSS E ST 20C, HPC definition

## High Priority (tele)Command (HPC, 3.2.29)

- refers to electrical/electronic items
- it is defined as

*command originated from ground and issued by the telecommand decoder for essential spacecraft functions without main on board software intervention*

- It is important to stress that it is the sort of command that needs to be actuated *without any software intervention*, HPC's are normally used in contingency cases to access redundancy of essential functions as per previous definition

# ECSS E ST 20C, HV definition

ECSS-E-HB-20-05A  
High voltage  
engineering and design  
handbook

## High Voltage (HV, 3.2.30)

- refers to electrical/electronic items or wires/harness
- it is defined as

*AC or DC voltage at which partial discharges, corona, arcing or high electrical fields can occur*

- To understand the underlying phenomena, and to know which are the threats of HV in space applications, watch the following:

[Paschen movie](#)



# ECSS E ST 20C, SPFF definition (1/4)

## Single Point Failure Free (SPFF)

- Unfortunately it is not in the list of definitions, it appears in req. 4.2.1w (specifically discussed later in this presentation)
- In STD it refers to any electrical/electronic item, but it can be applied to any spacecraft part
- SPFF is intended as

*the quality of a item that is able to maintain its functionality and performance after any single (internal) failure*

# ECSS E ST 20C, SPFF definition (2/4)

## Single Point Failure Free (SPFF), discussion

- The way any electrical/electronic item would maintain its functionality and performance after any single failure is by *redundancy* and *protections*
- What is important to mention in reference to the SPFF definition is
  - Which are the "**failures**" we want to be robust against?
  - Is it **autonomous reconfiguration** of the SPFF item applicable ?

# ECSS E ST 20C, SPFF definition (3/4)

## Single Point Failure Free (SPFF), which “failures”?

- In theory, **any** possible failure shall be covered
- But any sensible person understands that this is **practically impossible to achieve** (a requirement shall be always verifiable...)
- The way the problem is resolved by dependability is to refer to a practical set of failure cases, which are **defined at EEE component level\***
- **Note that this is the basis of the electrical reliability of our spacecraft!**
- The very important messages here are the following
  - *Please adopt a EEE components failure mode catalogue for any project you might be involved (STD req.4.3.2b) – just refer to annex G of ECSS-Q-ST-30-02C*
  - *Please support the availability of FMECA performed at component level for any essential electrical/electronic unit which you might review or procure (STD req. 4.3.2c)*

# ECSS E ST 20C, SPFF definition (4/4)

**Single Point Failure Free (SPFF) approach, is it *autonomous reconfiguration* applicable?**

- That is an important point to be clarified as soon as possible in the life cycle of a space mission
- In the case of a new satellite procurement, define the strategy of autonomy versus failures possibly in the Mission Requirement Document (MRD) or in the System Requirement Specification (SRS)
- Other implications of autonomy vs SPFF approach are discussed in relation to req. 4.2.1w.

# ECSS E ST 20C, Electrical and electronic, table of contents

- Electronics and power subsystem, key principles
  - Electronics for space
  - Space power subsystem
- Key categories of requirements
  - Reliability
  - Functionality
  - Performance
- Why/when/how to use the STD
- Presentation of the main chapters
- Key STD Definitions
- Key STD requirements...  
.... NB, only a small, non exhaustive set of key requirements!
- Conclusions

***Reliability, Functionality, Performance***

# ECSS E ST 20C, **general**, key requirements

Where we are...

## Table of contents

Change log.....	3
<b>1 Scope .....</b>	<b>9</b>
<b>2 Normative references.....</b>	<b>10</b>
<b>3 Terms, definitions and abbreviated terms .....</b>	<b>11</b>
3.1 Terms from other standards .....	11
3.2 Terms specific to the present standard.....	11
3.3 Abbreviated terms .....	17
3.4 Nomenclature.....	18
<b>4 General requirements .....</b>	<b>20</b>
4.1 Interface requirements.....	20
4.1.1 Overview .....	20
4.1.2 Signals interfaces .....	20
4.1.3 Commands .....	21
4.1.4 Telemetry .....	23
4.2 Design.....	23
4.2.1 Failure containment and redundancy .....	23
4.2.2 Data processing.....	27
4.2.3 Electrical connectors.....	28
4.2.4 Testing.....	30
4.2.5 Mechanical: Wired electrical connections .....	31
4.2.6 Miscellaneous .....	32
4.3 Verification .....	32
4.3.1 Provisions.....	32
4.3.2 Documentation .....	33

# ECSS E ST 20C, general, key requirements

## Key requirement #1

4 General requirements

4.2 Design

4.2.1 Failure Containment and redundancy

***1. In the case of hot redundant essential functions, latching protection shall not be used unless it has an autonomous periodic reset.***

### Explanation:

The requirement typically applies to the overload/current protection features saving the main bus from load failure, when the load is an essential function operating in hot redundancy (for example, the reconfiguration or command decoder in the CDMU).

In this case, the overload protection cannot be a latching type without automatic periodic reset, on the contrary you might risk to lose one side (M or R) of the critical function with catastrophic consequences due to spurious EMC, ESD, SEE triggering.

# ECSS E ST 20C, general, key requirements

## Key requirement #2

4 General requirements

4.2 Design

4.2.1 Failure Containment and redundancy

***m. Disabling critical on-board autonomous functions shall be allowed only if an interlock mechanism is implemented, which prevents the disabling of both main and redundant functions at the same time.***

### Explanation:

By default, and to avoid errors that would be fatal to the mission, an automatism shall be implemented that switches ON (or does not allow the switch OFF) the redundant side of a critical on board autonomous function when the main side is switched OFF.

### Example

The switches commanding ON/OFF the (two essential) receivers in the spacecraft.



# ECSS E ST 20C, general, key requirements

## Key requirement(s) #3,4

4 General requirements

4.2 Design

4.2.1 Failure Containment and redundancy

- w. The spacecraft electrical system shall be single failure tolerant for unmanned mission and double failure tolerant for manned mission.***
- x. Occurrence of a non-destructive SEE after a failure shall not lead to the loss of the mission.***

## Explanation:

By default, any ESA satellite is considered as SPFF (DPFF for manned missions).

SEEs might cause the spurious activation of protections that would affect essential functions (as for example the Battery Discharge Regulator in a power system) and this is shall not be considered as a failure case.

# ECSS E ST 20C, general, key requirements

## Pause... again on SPFF approach

The approach towards failure management on ESA satellites is a very important *technological, design* and *cost/schedule* driver.

It is extremely important that the approach is **agreed** with the Prime **as soon as applicable** (e.g. at system requirement review)

SPFF is our standard option, but this does not mean that it could not be waived

# ECSS E ST 20C, general, key requirements

## Key requirement #5

4 General requirements

4.2 Design

4.2.3 Electrical connectors

***a. A connector carrying source power or external test connectors on units shall have no contact areas exposed to possible short circuit during mating and de-mating process.***

## Issue:

Sometimes (e.g. for a battery) the power is necessarily exposed on both sides! In this case, round-type connectors are preferred over "D" types. There are also other interesting options (see ESCC Detail Specification No. 3401/081 to 084)

In the picture you see to a flight battery connector, damaged because of wrong mating.



# ECSS E ST 20C, general, key requirements

## Pause... again on connectors, key requirement #6

4 General requirements

4.2 Design

4.2.3 Electrical connectors

***m. The following shall be performed for any connector the loss of which can lead to the loss of the mission:***

***1. Document the connector in the single point failure list***

***2. Verify and document its integrity up to the highest spacecraft integration level, to avoid accidental demating.***

- The requirement addresses the dreadful **loss of a critical connector**... the main issue is to establish a clean and robust verification and validation approach of the relevant fixation to be sure that it would not happen during launch and flight (on the contrary, use round connectors with locking mechanism)

# ECSS E ST 20C, general, key requirements

## On redundancy testing

4 General requirements

4.2 Design

4.2.4 Testing

- Some requirements\*\* address the **(necessary) testing of redundancies** and of some protections that are **contained within a unit**. The redundancies test is essential to be sure that your SPFF approach is alive at the time you launch the spacecraft!
- Note that these **testing requirements** are **design drivers**, since you need to be able to “inject” stimuli simulating a failure.

\*\* See next chart...

# ECSS E ST 20C, general, key requirements

## On redundancy testing

4 General requirements

4.2 Design

4.2.4 Testing

\*\*

***g. The redundancy of parts and functions, which failure can lead to the loss of the mission or human injury, shall be verified by test simulating the failure event.***

***h. Circuits meant for on-ground testing or unused circuits shall not create or be sensitive to the noise expected during operation.***

***i. The protection of functions, which failure can lead to the loss of the mission or human injury, shall be verified by test simulating the failure event.***

***m. All redundant functions and protection functions shall be tested, up to the highest possible level of integration of the unit.***

# ECSS E ST 20C, electrical power, key requirements

Where we are...

<b>5 Electrical power</b> .....	<b>34</b>
5.1 Functional description .....	34
5.2 Power subsystem and budgets.....	34
5.2.1 General.....	34
5.2.2 Provisions .....	34

- 5.2 Power subsystem and budgets
- 5.2.2 Provisions
- 5.2.2.2 Engineering process

A set of requirements (a. to d.) is dedicated to **power and energy budgets**, to be produced and maintained **both** for **peak** and for **average** power demand. They are important but intuitively easy to understand (so no specific discussion).

# ECSS E ST 20C, power generation, key requirements

Where we are...



ECSS-E-ST-20C Rev.1  
15 October 2019

5.2.2	Provisions .....	34
5.3	Failure containment and redundancy.....	36
5.4	Electrical power interfaces.....	37
5.5	Power generation .....	38
5.5.1	Solar cell, coverglass, SCA and PVA qualification .....	38
5.5.2	Solar array specification and design .....	38
5.5.3	Solar array power computation .....	41
5.5.4	Solar array drive mechanisms.....	44
5.6	Electrochemical Energy Storage .....	44
5.6.1	Applicability.....	44
5.6.2	Batteries .....	45
5.6.3	Battery cell.....	47
5.6.4	Battery use and storage.....	48
5.6.5	Battery safety.....	49



# ECSS E ST 20C, energy generation, key requirements

The key requirements that relate to function and performance are intuitively easy to understand

- a solar array has to generate power
- aspects which have to be addressed in the power calculation are itemised

The key requirements relating to **reliability** require some more thought....

# ECSS E ST 20C, energy generation, key requirements

The electrical components included in order to ensure **reliability** are:

- Bleed resistor
- Blocking diodes
- Shunt diodes
- Redundant connections

# ECSS E ST 20C, energy generation, key requirements

## Key requirement #7 (from Rev.1 of the STD)

5.5 Power generation

5.5.2 Solar array specification and design

***e) NOTE Good practices in accordance with the present state of the art (maximum current of 0.6A), are to:***

***...***

- implement string blocking diodes***

***...***

### **Explanation:**

- Blocking diodes prevent flow of current from the bus to the solar array in case the string output voltage is less than the bus voltage.

### **Example:**

- A string is unable to maintain the bus voltage in photovoltaic mode e.g. due to partial shadow. In the absence of a blocking diode, this string would sink power.

# Slide 75 of the preparatory presentation...

Equivalent electrical diagram of a single junction cell

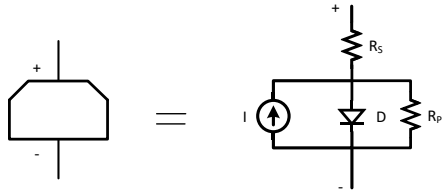

Equivalent electrical diagram of a triple junction cell

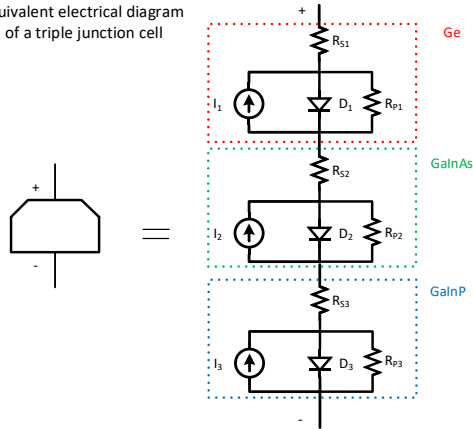

## Strings are connected in parallel to make sections

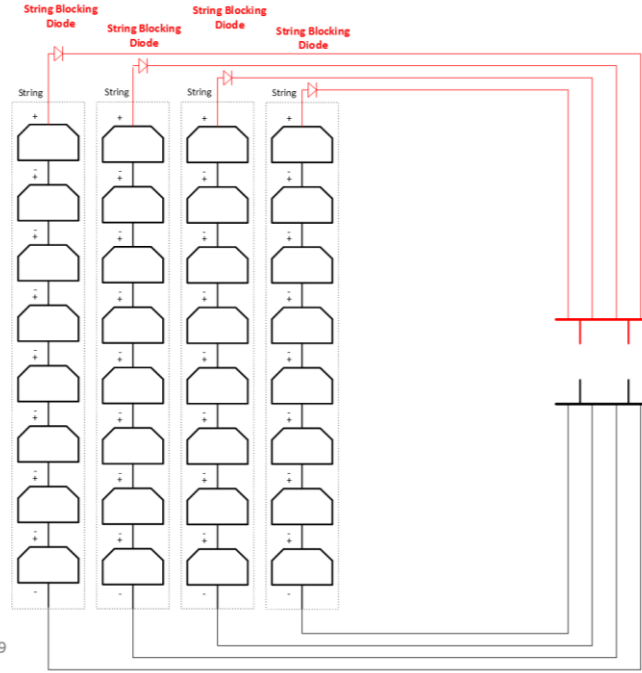

Specific redundancy!

Additional strings are added for redundancy to cover for all possible failures / loss factors (inherent failures, micrometeoroids, ESD effects, etc)

# ECSS E ST 20C, energy generation, key requirements

## Key requirement #8

5.5 Energy generation

5.5.2 Solar array specification and design

*i. In the flight configuration, bleeding resistors shall be implemented.*

### Explanation:

- Bleed resistors limit
  - differential charging between solar panel and spacecraft body e.g. due to different secondary electron emission rates
  - flow of current from the solar array to ground in case of short to the solar array panel substrate

### Example:

- Failure of insulation between solar cells and panel substrate e.g. due to micrometeorite impact

# ECSS E ST 20C, energy generation, key requirements

## Key requirement #9

5.5 Energy generation

5.5.2 Solar array specification and design

*q. Solar cells shall be protected against any deleterious reverse bias conditions.*

### Explanation:

- For triple-junction cells, each cell must be protected by a dedicated **by-pass diode** since unprotected reverse bias operation would usually cause component failure. The reverse voltage of the cell is limited to the forward voltage of the by-pass diode junction.

### Example:

- Within one string which is operating in photovoltaic mode, one cell is partially shadowed and forced to operate in reverse-bias in order to conduct the string current

# ECSS E ST 20C, energy generation, key requirements

- Solar array final configuration with string blocking diodes and cell bypass diodes

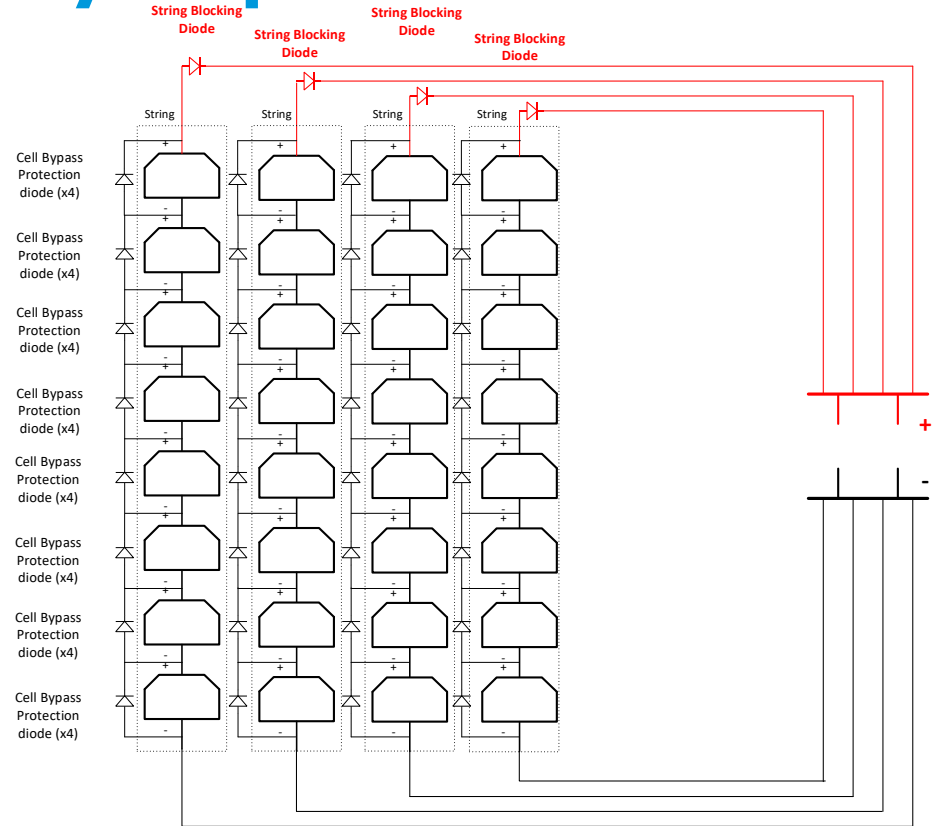

# ECSS E ST 20C, electrochemical energy storage, key requirements

Where we are...



ECSS-E-ST-20C Rev.1  
15 October 2019

5.2.2	Provisions .....	34
5.3	Failure containment and redundancy.....	36
5.4	Electrical power interfaces.....	37
5.5	Power generation .....	38
5.5.1	Solar cell, coverglass, SCA and PVA qualification .....	38
5.5.2	Solar array specification and design .....	38
5.5.3	Solar array power computation .....	41
5.5.4	Solar array drive mechanisms.....	44
5.6	Electrochemical Energy Storage .....	44
5.6.1	Applicability.....	44
5.6.2	Batteries .....	45
5.6.3	Battery cell.....	47
5.6.4	Battery use and storage.....	48
5.6.5	Battery safety.....	49



# ECSS E ST 20C, electrochemical energy storage, key requirements

The key requirements that relate to function and performance are intuitively easy to understand

- An electrochemical cell has to store the energy
- An electrochemical cell has to provide energy when the solar power is not available or not sufficient during all the mission phases

**Reliability** is related to the cell construction and the battery assembly.

A lot of care has to be paid on the **expected** versus **qualified** environmental conditions, and on integration aspects.

# ECSS E ST 20C, electrochemical energy storage, key requirements

## Key requirement #10

5.6 Electrochemical energy storage

5.6.3 Battery cell

***g. The battery supplier shall inform the customer of any change in design, materials or process from cells which have experienced life testing or flight.***

### Explanation:

A review of the cell construction is necessary before starting an overview of the battery construction and to consider the failure modes of the battery. Any change in materials, processes, design can have impacts on the reliability.

### Example:

Any change in tabs or protection devices like Positive Temperature Coefficient thermistor (PTC) will affect the reliability of the cell

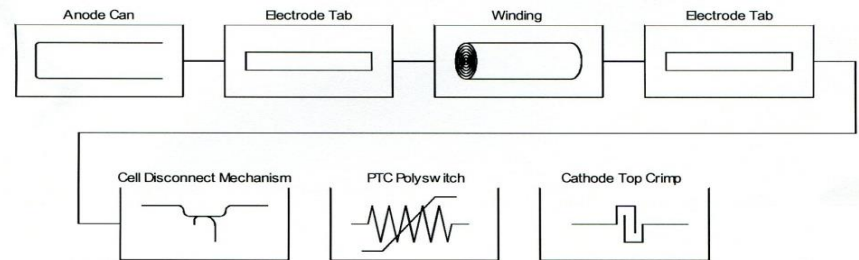

Figure 3-1: Cell Reliability Block Diagram

# ECSS E ST 20C, electrochemical energy storage, key requirements

## Key requirement #11

5.6 Electrochemical Energy Storage

5.6.2 Batteries

***a. The battery shall be specified to ensure the energy balance in each mission phase during operational life, including contingency modes resulting from a single failure for unmanned missions and two failures for manned missions.***

### Explanation:

Batteries must meet requirements in all phases of the mission. It is very important to find worst cases that are leading to battery sizing. If a mission phase is overlooked, battery sizing may be incorrect.

### Example:

LEOP, safe mode might be the battery **sizing driver** *more* than nominal operational mode

# ECSS E ST 20C, electrochemical energy storage, key requirements

## Key requirement #12

5.6 Electrochemical Energy Storage

5.6.2 Batteries

***m. Battery and spacecraft thermal design shall ensure together that:***

***1. maximum and minimum qualification temperature of cell operation under intended cycling conditions are not exceeded***

***...***

### **Explanation:**

If cells are cycled outside their temperature range, their performance is affected in term of cycle life, rate capability

### **Example:**

Rate (Ah) capability at 0°C is different from the rate capability at 15-20°C

# ECSS E ST 20C, electrochemical energy storage, key requirements

- During integration phase(AIT)
  - Live battery connector was allowed to touch the wall of TV chamber
- Is the battery flight worthy?
  - How do you ensure the cell was not overdischarged?
  - Were PTCs (resettable cell protections against high current, external shorts) activated?  
If yes, how to be sure these PTC are exactly identical as previously and will play fully their role in the future?
  - Impacts on reliability?
  - Impacts on performance?

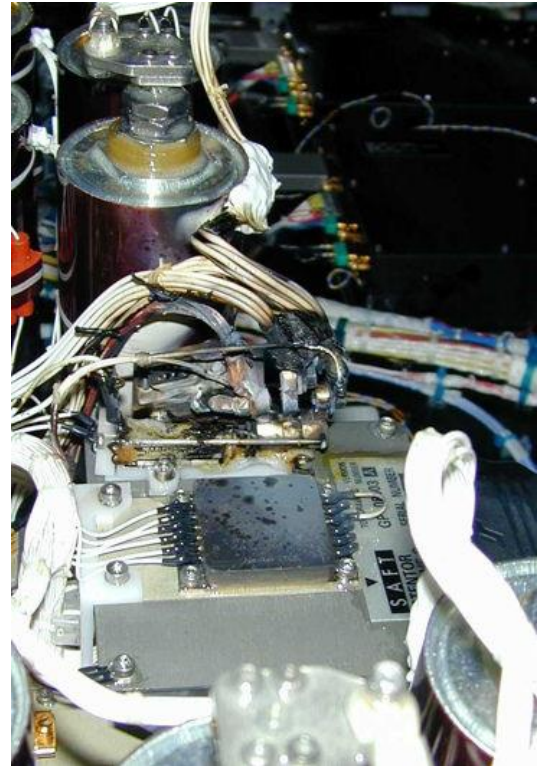

# ECSS E ST 20C, electrochemical energy storage, key requirements

## Key requirement #13

5.6 Electrochemical Energy Storage

5.6.4 Battery use and storage

***c. Flight batteries should not be used for ground operations to prevent any possible damage and subsequent degradation of life performance.***

- **i.e. Battery simulators should be used whenever possible.**
- At most flight batteries need only be used for mechanical and thermal vacuum testing

# ECSS E ST 20C, electrochemical energy storage, key requirements

## Key requirement #14

5.6 Electrochemical Energy Storage

5.6.2 Batteries

- 1. A logbook shall be maintained by the supplier for each flight battery starting with the first activation after battery assembly...***

NOTE The logbook is used for the following purposes:

- to ensure compliance with storage, handling and operational requirements before launch (e.g. maximum time allowed at upper temperature limits, correct scheduling of maintenance activities);
- to allow verification of flight worthiness.
- special care has to be paid to external current discharge paths during integration phases.

Be careful to properly **fill in the logbook**.

It will help to assess battery health status, especially in case of an anomaly during testing.

Logbook is overlooked and usually... empty, if it even exists!

# ECSS E ST 20C, power conditioning and control, key requirements

Where we are...

5.6	Electrochemical Energy Storage .....	44
5.6.1	Applicability.....	44
5.6.2	Batteries .....	45
5.6.3	Battery cell.....	47
5.6.4	Battery use and storage.....	48
5.6.5	Battery safety.....	49
5.7	Power conditioning and control.....	50
5.7.1	Applicability.....	50
5.7.2	Spacecraft bus.....	51
5.7.3	Battery Charge and Discharge Management .....	55
5.7.4	Bus under-voltage or over-voltage .....	57
5.7.5	Power converters and regulators .....	58
5.7.6	Payload interaction .....	59
5.8	Power distribution and protection .....	60
5.8.1	General.....	60
5.8.2	Harness .....	64
5.9	Safety.....	66
5.10	High voltage engineering.....	66
5.11	Verification .....	67
5.11.1	Provisions .....	67
5.11.2	<<deleted>> .....	67



# ECSS E ST 20C, power conditioning and control, key requirements

The power conditioning and control electronics part of the power subsystem has to accomplish the following

- shall **condition, control, monitor and distribute** electrical power from the solar generator to the spacecraft users
- shall **manage battery charge / discharge** to fulfill satellite power demands throughout all mission phases in the presence of all environments actually encountered
- shall be **capable of operating continuously** under all operational conditions of the mission including contingency situations. No damage or degradation shall result from intermittent or cycled operation
- shall provide **adequate status monitoring and telecommand interfaces** necessary to operate the sub-system and permit evaluation of its performance (during ground testing and in-flight operations) and failure detection and recovery.

# ECSS E ST 20C, power conditioning and control, key requirements

The power conditioning and control electronics subject that is required by the STD has the following features:

- It is **SPFF** versus its functional and performance requirements in all phases of the mission including integration ones
  - Req. 5.7.2 a,b,e,f,r,s,t; 5.7.3 c,i; 5.7.4 d,e; 5.7.6 b,d; 5.8.1 a,c,d,j,k
- In its basic features, it is **fully autonomous** and **self-contained**
  - Req. 5.7.2 c,d; 5.7.3 g,h; 5.7.4 c
- It is **able to start from either of the relevant power sources**, irrespective if the other is able to provide power or not
  - Req. 5.7.2 q
- It respects **stringent performance requirements**, such to avoid any compatibility issues with power sources and load
  - Req. 5.7.2 g,h,i,k,m,n,o,p; 5.7.3 a; 5.7.4 a; 5.7.5 a,b,c,d,e,f,g,h; 5.8.1 h,k,n,q,r,s,t,u,v; 5.8.2 e,f; 5.10 b,c,d,e

# ECSS E ST 20C, power conditioning and control, key requirements

## Key requirement #15

- 5.7 Power conditioning and control
- 5.7.2 Spacecraft bus

***o. At the point of regulation, the impedance mask of a fully regulated bus, operating with one source shall be below the impedance mask shown in Figure 5.1.***

## Explanation:

The requirement is strictly related with the dynamic transient performances required from a regulated bus (see 5.7.2i). In particular,

- the **plateau** of the impedance (from 100hz to 10Khz) is derived from a simple calculation, in order to allow a maximum 1% main bus voltage fluctuation for a load modulation up to 50%.
- The behaviour **over 10Khz** results from the bandwidth limitation of the power subsystem voltage control loop (assumed to be 10Khz) and the effect of the capacitor bank at high frequencies.
- the behaviour **below 100Hz** results from assumed proportional-integral power subsystem voltage control loop (with a zero at 100hz) and the residual effect of the connection resistance from regulation point to output connector at frequencies below 10Hz.

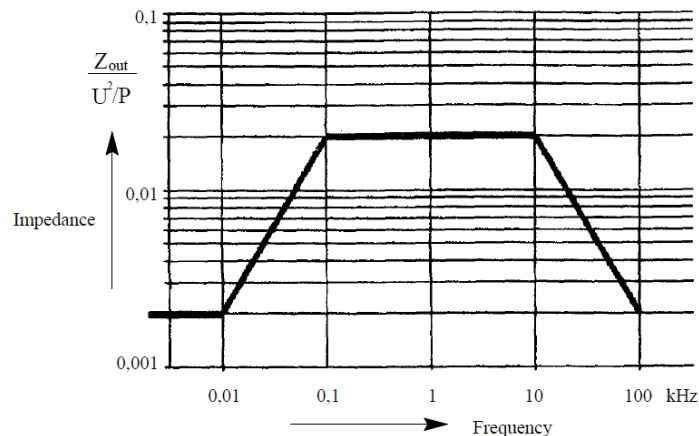

U = Nominal regulated output voltage (Volt)  
P = Power capability (Watt)

# ECSS E ST 20C, Electronics and power subsystem, key requirements

## Key requirement #16

5.7 Power conditioning and control

5.7.3 Battery Charge and Discharge Management

***a. On-board battery chargers shall be designed to ensure charging of a battery discharged down to zero volts.***

## Explanation:

Unfortunately this requirement might be misunderstood... the correct meaning is that the battery chargers shall be **able to recharge a battery** that is **completely drawn** (e.g. that it has been depleted to a negligible state of charge).

The reason of this requirement is to be sure that our satellites can indeed recover from a major power loss (dead bus case, see SOHO experience)... it is a minor design request can save from disaster!

# ECSS E ST 20C, Electronics and power subsystem, key requirements

## Key requirement #17

5.7 Power conditioning and control

5.7.4 Bus under-Voltage or over-voltage

***c. The ultimate non-essential load disconnection circuit shall be implemented as a full hard-wired chain from sensor to actuator.***

## Explanation:

As previously explained, there should be a hardware safety net to save the mission from disaster, like there are hard-wired braking possibility in a car provided with a servo-braking system.

Over this hard limit, there are no prescription on how load disconnection shall be performed.

More details are given in the attached file



**UV protections**

# ECSS E ST 20C, power conditioning and control, key requirements

## Key requirement #18 and following

5.8 Power distribution and protection

5.8.1 General

***q. Whenever two or more blocks are connected in cascade, the stability of the cascade between each source block and load block shall be analysed with the source and load impedances characterised in compliance with Figure 5-2.***

***... see also the following requirements 5.8.1r to 5.8.1v***

## Explanation:

The requirement applies to all power source –load combinations that you might encounter within or outside the power subsystem (SA-PCDU, BATT-PCDU, LCL-Load, etc).

Starting from the assumption that both source and load block do meet stability requirements, it is *not necessary true* that their cascade would be stable.

**Stability is a must** (on the contrary our system will not behave as expected and additional stress on components, unexpected failures and failure propagation patterns would appear).

More details in the attached file.



Stability of  
cascaded blocks

## What happens if 5.8.1b is not ... verified:

We are not sure to have a stable system !

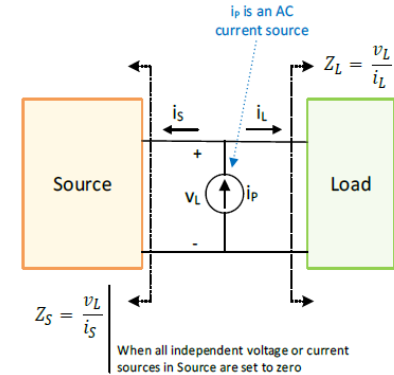

Figure 5-2: Source and load impedance characterisation

**ECSS-E-ST-20-20C,  
ECSS-E-HB-20-20A,  
Electrical design and interface  
requirements for power supply**

TEC-E

ESA-ESTEC

rev1.0

# ECSS-E-ST&HB-20-20, Electrical design and interface requirements for power supply

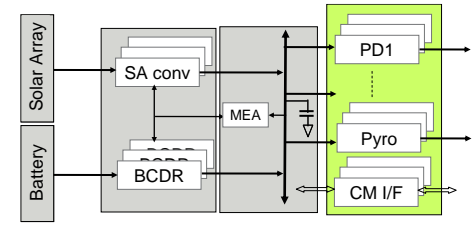

- In reality, both the STD and the HB deal specifically with (standard) interfaces for power distribution based on LCLs and RLCLs
  - Standard “plugs” power for all users on board of institutional spacecraft!
  - Product oriented standard: enables availability of power distribution “products” with defined characteristics (classes & other features)
  - Agreed with Large System Integrators and Equipment Manufacturers!

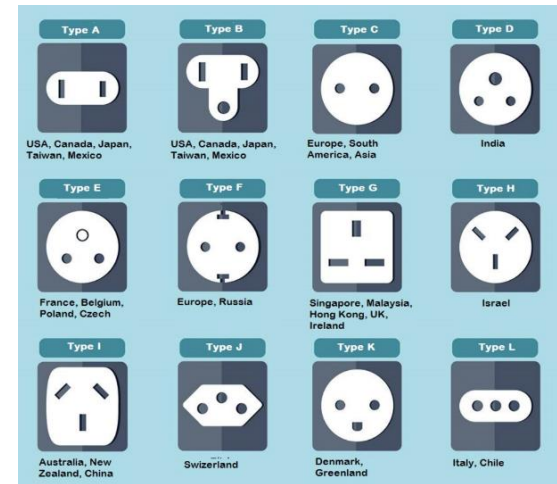



# ECSS-E-ST&HB-20-20, Electrical design and interface requirements for power supply

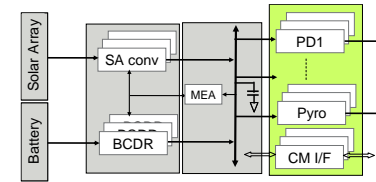

## ➤ Fuses

One shot device: no reset function, uncertainties of the fusing conditions wrt current & time.

The power system needs to be able to absorb the heavy transient resulting from a fuse blowing event.

=> Typically used in high recurrent telecom satellites platforms

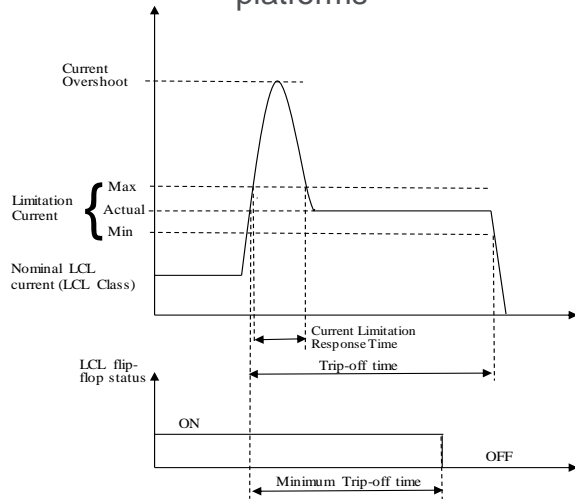

## ➤ Latching Current Limiters

The **LCL** is a solid state switch provided with **current limitation** (from a fraction of an Amp to several Amps).

It normally works in saturated mode (e.g. it presents a **small resistance in series** with the load current).

The voltage drop is kept typically within 1% of the nominal Main Bus voltage level.

In case of an overload on the line, the current limitation feature enters quickly into action, and the line is opened if the **overload duration** exceeds the **trip off time** (some ms to tens of ms).

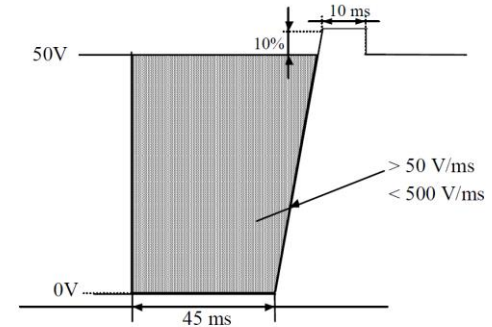

# ECSS-E-ST&HB-20-20, Electrical design and interface requirements for power supply

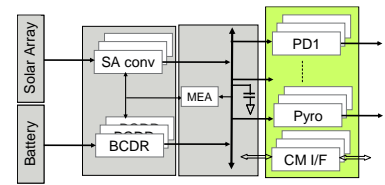

## ➤ Foldback Current Limiters (FCLs)

The FCL is a solid state device provided with a **foldback current limitation**. It is not a switching device and normally works in saturated mode (as the LCL).

In case of an overload on the line, the current is reduced according to the foldback characteristic.

The FCLs are usually protecting the **essential loads** (receivers, decoders in the on board data handling)

The present trend is to substitute FCLs with Retriggerable LCLs (RLCLs) especially for dissipation reasons in case of overload.

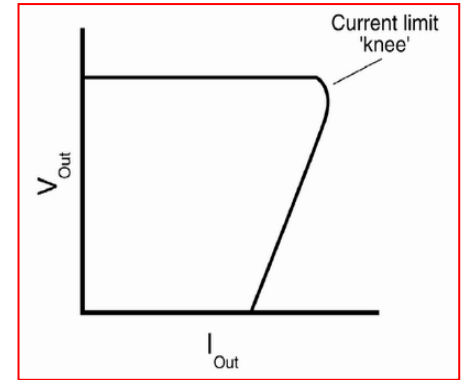

# ECSS-E-ST&HB-20-20, Electrical design and interface requirements for power supply

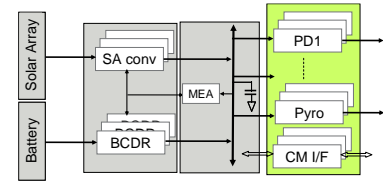

## ➤ Retriggerable Latching Current Limiters (RLCLs)

The **RLCL** is an LCL provided with retrigger capability.

It works in the same way described for LCL, but after the trip off event is automatically restarting if the overload persists.

The RLCLs are usually protecting the *essential loads*.

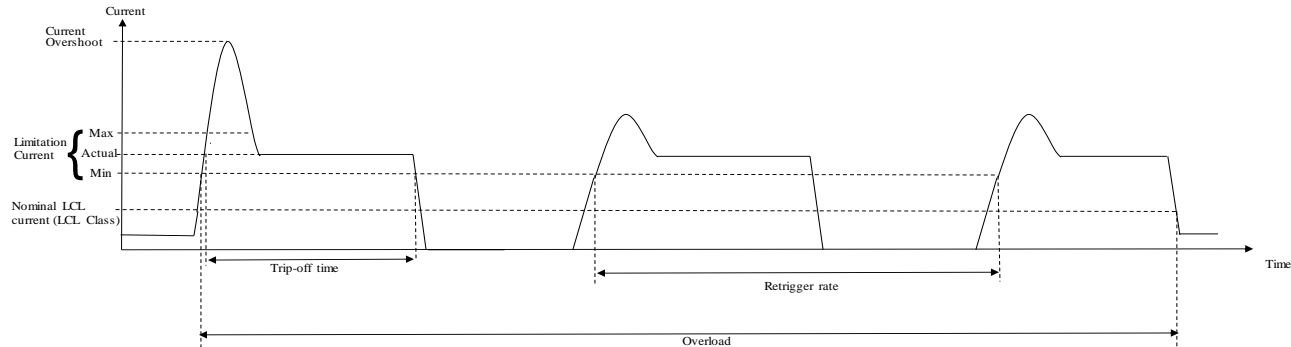

# ECSS-E-ST&HB-20-20, Electrical design and interface requirements for power supply

## Document structure, STD

- Conventional ECSS standard document...
- ... but with **summary synoptic table** (Requirement Mapping table, see Figure 6 below)
- Requirements grouped under following categories
  - **Functional, source** (section 5.2)
  - **Functional, load** (section 5.3)
  - **Performance, source** (section 5.4)
  - **Performance, load** (section 5.5)



Reference	Text of the requirement	Feature	Sub-feature	Conditions	Applicability	Applicability level	Verification
5.2.18.1.1a	The RLCL state shall automatically be recovered to ON conditions after a spurious switch OFF.	Noise immunity	RLCL spurious switch OFF	Nominal	RLCL	Equipment	RoD, A, 
5.2.18.2.1a	Spurious disable of RLCL retriggering memory cell and of RLCL ON/OFF status memory cell shall not result in the loss of the relevant load.		RLCL spurious effects	Nominal	RLCL	Equipment	RoD, A, 

Figure 6, Example of requirements mapping (from STD, Annex A)

# ECSS-E-ST&HB-20-20, Electrical design and interface requirements for power supply

## HB

- **Explanatory** document (principles of operation, important issues)
- **Justification** of STD requirements
- **Key aspects**: interactions LCL and load (at start up, overload, switch-off conditions, both in time and in frequency domain, considering normal operational conditions but also failure cases)
- For the **system engineers**, this document explains the detailed issues at circuit level and the impacts of the requirements for the design of LCLs.

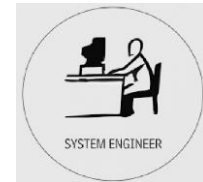

- For **design engineers**, this document gives insight and understanding on the rationales of the requirements on their designs.

# ECSS-E-ST&HB-20-20, Electrical design and interface requirements for power supply

## APPLICABILITY

- For missions traditionally provided with power distribution and protection by LCLs/RLCLs (science, earth observation, navigation)
- for power systems, and in general for satellites, required to be **Single Point Failure Free**.
- to the main bus power distribution by LCLs/RLCLs to **external** satellite loads (no internal power system protections)

# ECSS-E-ST&HB-20-20, Electrical design and interface requirements for power supply

## ASSUMPTIONS

Table 1 - Reference Power Bus Specifications

Power Bus type :		REGULATED BUS [V]		UNREGULATED BUS [V]	
		28V	50V	28V	50V
Nominal DC Bus Voltage Range at regulation point	Min	28 -1%	50 -1%	22	32
	Max	28 +1%	50 +1%	38	52
Nominal DC Bus Voltage Range at load side	Min	28 -5%	50 -5%	22	38
	Max	28 +1%	50 +1%	38	52
Abnormal DC Bus voltage range	Min	0	0	0	0
	Max (fault tolerance)	N/A	N/A	40	55
	Max (fault emission)			38	52
Nominal Bus ripple voltage	Max	Acc. to ECSS-E-ST-20C		Up to $\pm 500$ mVpp in the range of 30 Hz to 50 MHz.	
Nominal Bus voltage transients	Max	Acc. to ECSS-E-ST-20C		$\pm 1,4$ V for load steps of 50%, with $dI/dt=1A/\mu s$	$\pm 2,5$ V for load steps of 50%, with $dI/dt=1A/\mu s$
Abnormal Bus voltage transients	Max	0 to 34 max	0 to 60 max	Within Power Bus abnormal DC limits	

### Other assumptions:

- maximum qualification temperature of the host unit is 70°C
- MB voltage derivative from 0 to 0.1V/ $\mu s$

# ECSS-E-ST&HB-20-20, Electrical design and interface requirements for power supply

## LCL, RLCL CLASSES

Table 2: LCL classes

	LCL class									LCL class								
	1	2	3	4	5	6	8	10		1	2	3	4A	4B	5	6	8	10
Regulated Bus voltage [V]	28									50								
Unregulated Bus voltage [V]	22 to 38									32 to 52								
Class current [A]	1	2	3	4	5	6	8	10		1	2	3	4	4	5	6	8	10
Min limitation current [A]	1,1	2,2	3,3	4,4	5,5	6,6	8,8	11		1,1	2,2	3,3	4,4	4,4	5,5	6,6	8,8	11
Max limitation current [A]	1,4	2,8	4,2	5,6	7	8,4	11,2	14		1,4	2,8	4,2	5,6	5,6	7	8,4	11,2	14
Trip-off min [ms]	10	10	6	6	4	2	2	1,5		10	6	4	2	4	2	2	2	1,5
Trip-off max [ms]	20	20	12	12	8	4	4	3		20	12	8	4	8	4	4	4	3
Max load capacitance [µF]																		
Regulated bus	272	545	490	653	545	327	436	408		152	183	183	122	244	152	183	244	229
Unregulated bus	203	405	365	486	405	243	324	304		148	178	178	118	237	148	178	237	222

Table 3: RLCL classes

	RLCL class					RLCL class			
	0,5	1	2A	2B		0,5	1A	1B	2
Regulated Bus voltage [V]	28					50			
Unregulated Bus voltage [V]	22 to 38					32 to 52			
Class current [A]	0,5	1	2	2		0,5	1	1	2
Min limitation current [A]	0,55	1,1	2,2	2,2		0,55	1,1	1,1	2,2
Max limitation current [A]	0,7	1,4	2,8	2,8		0,7	1,4	1,4	2,8
Trip-off min [ms]	10	10	4	10		10	4	6	4
Trip-off max [ms]	20	20	8	20		20	8	12	8
Max load capacitance [µF]									
Regulated bus		136	272	218	545	76	61	91	122
Unregulated bus		101	203	162	405	74	59	89	118



# ECSS-E-ST&HB-20-20, Electrical design and interface requirements for power supply

## HLCL

Table 4: HLCL classes

Characteristic	HLCL class										HLCL class									
	1	2	3	4	5	6	8	10	1	2	3	4	5	6	8	10				
Regulated Bus voltage [V]	28										50									
Unregulated Bus voltage [V]	22 to 38										32 to 52									
Class current [A]	1	2	3	4	5	6	8	10	1	2	3	4	5	6	8	10				
Min limitation current [A]	1,1	2,2	3,3	4,4	5,5	6,6	8,8	11	1,1	2,2	3,3	4,4	5,5	6,6	8,8	11				
Max limitation current [A]	1,4	2,8	4,2	5,6	7	8,4	11,2	14	1,4	2,8	4,2	5,6	7	8,4	11,2	14				
Trip-off min [ms]	0,5	0,5	0,5	0,5	0,5	0,5	0,5	0,5	0,5	0,5	0,5	0,5	0,5	0,5	0,5	0,5				
Trip-off max [ms]	2	2	2	2	2	2	2	2	2	2	2	2	2	2	2	2				
Max parasitic capacitance [µF]																				
Regulated bus	1	1	1	1	1	1	1	1	1	1	1	1	1	1	1	1				
Unregulated bus	1	1	1	1	1	1	1	1	1	1	1	1	1	1	1	1				

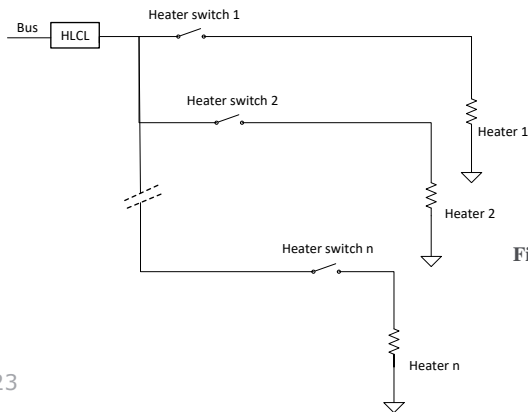

HLCL, or Heater (group) LCL

Figure 4, HLCL application

# ECSS-E-ST-20-06C, Rev.1 Spacecraft Charging

TEC-**EPS**

ESA-ESTEC

rev1.**1**

# ECSS-E-ST-20-06C, Spacecraft Charging, Introduction

- Document
  - ECSS-E-ST-20-06C Spacecraft Charging, **Rev.1, issue 15 May 2019**
  - Part of ECSS-E-ST-20C Electrical and Electronic engineering
- Scope of the document
  - Applicable to all spacecrafts, subject to tailoring
  - Covers the electrical charging of spacecraft and surfaces due to the space environment (not ground or atmospheric effects)
  - Gives requirements to assess, and avoid or acceptably minimize hazardous effects of spacecraft charging

# ECSS-E-ST-20-06C, Spacecraft Charging, Background

Space is not empty.

- It is filled with 'plasma' (electrons and ions) of low density but high temperature ( $\sim 1 \times 10^8 \text{K}$  or  $10 \text{keV}$  in GEO)
- Even higher energy particles ( $\sim \text{MeV}$ ) are in the radiation belts
- The environment varies with location and 'space weather'

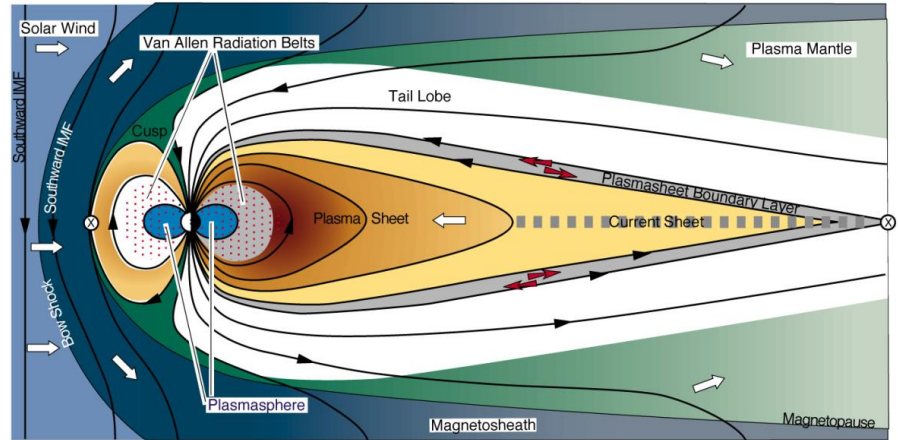

These charged particles stick to the spacecraft, charging it electrically.

**Sparks** (electrostatic discharges) from one charged surface to another interfere with and damage electrical circuits and components.

- **Many** spacecraft **failures** and **anomalies** have resulted.

# ECSS E ST 20 06C, Spacecraft Charging, Background

Both the environment and materials play a role in spacecraft charging

- ECSS-E-ST-10-04C Space Environment standard describes the aspects of the space environment that have a crucial influence on spacecraft charging. In particular:
  - Plasma – ions and electrons, 0eV to ~50keV
  - Energetic particle radiation, ~100keV to ~5MeV
  - Sunlight – ejects negative charge by photoemission
- Materials differ in terms of conductivity and yield of secondary emission and photo-emission.

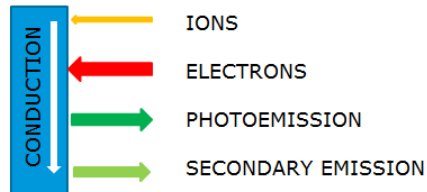

Surface potential arises from the total current from electrons, ions, photoemission, secondary emission, conducted current and more...

Important: Different surfaces reach different potentials.

# ECSS E ST 20 06C, Spacecraft Charging, Effects

Most critical engineering concerns

- Surface charging due to charge accumulation on **external** surfaces. High levels of differential potential may lead to Electrostatic Discharge (ESD).
- **Internal** charging due to more energetic penetrating electrons. ESDs may be generated within the spacecraft Faraday cage and in close proximity to vulnerable components.
- ESDs on the **solar array** can cause secondary arcing

Additional concerns include

- Current leakage and power loss effects on solar arrays
- Environment modification. Can be a critical problem for scientific plasma measurements
- Electric propulsion interactions with the environment
- Electrostatic tethers current collection and voltage generation

# ECSS E ST 20 06C, Spacecraft Charging, Requirements

See clauses 6 to 11 of the standard for detailed requirements

'Platinum' requirements

1. Dielectric materials at not more than **-2kV** w.r.t. conductors (6.2.1)
2. Dielectric materials at not more than **+300V** w.r.t. conductors (6.2.1)
3. Internal electric field not more than 10MV/m (6.2.1)
4. An ESD on the solar array shall not lead to a sustained arc (7.2.3.1)

Other requirements are principally derived from these, including:

- Grounding of conductors
- Selection of leaky insulators
- Selection of high photo/secondary emission yield materials
- Testing of solar arrays

# ECSS E ST 20 06C, Spacecraft Charging, Protection programme

There needs to be a **plan** for assessments **to demonstrate that requirements are met** (Clause 5)

Requirements may be shown to be satisfied in the design by:

- Simple analyses e.g.  $\text{voltage} = \text{worst-case current} \times \text{resistance}$
- Computer simulation of spacecraft charging
- Laboratory testing under vacuum irradiation

The design must be verified by measurement, inspection and testing

e.g. checking the grounding of MLI thermal blankets

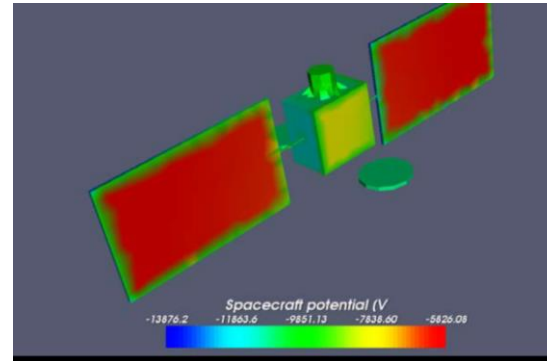



# ECSS E ST 20 06C, Spacecraft Charging, Tailoring

- Different requirements apply in different orbits because of their different environment (Annex B)
- LEO
  - Surface charging (clause 6) **for scientific s/c only**
  - Solar array ESD effects (clause 7)
  - High-voltage interactions (clause 8)
- PEO
  - Surface charging (clause 6) **with some relaxation**
  - Solar array ESD effects (clause 7)
  - High-voltage interactions (clause 8)
- MEO/GEO
  - Surface charging (clause 6)
  - Solar array ESD effects (clause 7)
  - **Internal parts and materials** (clause 9)

# ECSS E ST 20 06C, Spacecraft Charging, Tailoring

- Special requirements apply for
  - Electrodynamic Tethers - (clause 10)
  - Electric propulsion – (clause 11)
- Interplanetary missions and non-Earth planetary environments
  - Not specifically covered by the standard but the 'platinum' requirements are still relevant

# ECSS-E-ST-20-07C Rev. 2

## Electro-magnetic compatibility

TEC-EPE

ESA-ESTEC

Issue 1.0

# ECSS-E-ST-20-07C Rev. 1

## Electromagnetic compatibility, introduction

### Documents of interest

- **ECSS-E-ST-20C (Ch. 6)**, called "20C" in this presentation
- **ECSS-E-ST-20-07C Rev. 1**, called "20-07C" in this presentation

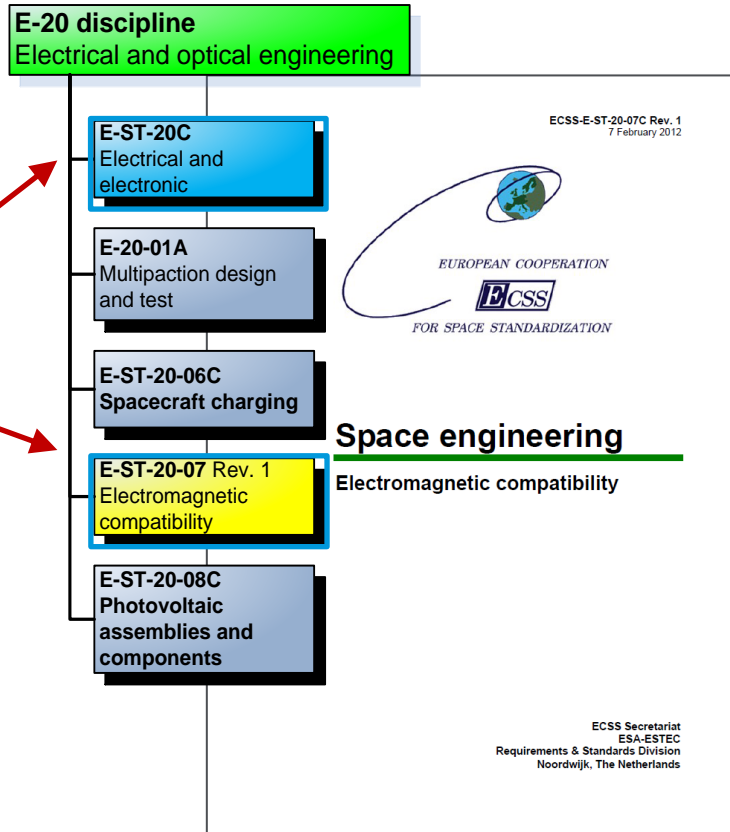

# ECSS-E-ST-20-07C Rev. 2

## Electromagnetic compatibility, introduction

- Additional documents of interest  
ECSS-E-HB-20-07A, EMC handbook

Throughout the presentation, the requirements further discussed in the EMC handbook (ECSS-E-HB-20-07A) are tagged with [HB] + relevant section #.

HB

# ECSS-E-ST-20-07C Rev. 2

## Electromagnetic compatibility, brief history

### Brief history

Birth of the ECSS-E-ST-20-07C Rev. 1

1999: ECSS Standard, Electrical and Electronic

ECSS-E-20A: one chapter (Ch. 6) is about EMC

2004: Introduction of “level 3” ECSS standards, appointment of a WG drafting the ECSS-E-20-07A

2008: ECSS Standard, Electromagnetic Compatibility

Release of the ECSS-E-ST-20-07C (new reference)

2012: ECSS Standard, Electromagnetic Compatibility

Release of the ECSS-E-ST-20-07C Rev. 1

2021: ECSS Standard, Electromagnetic Compatibility

Release of the **ECSS-E-ST-20-07C Rev. 2**

### General remarks:

- Some heritage from US DoD military standards, e.g. MIL-STD-461
- Most heritage from European space projects EMC requirements (but correcting recurrent anomalies)
- “General system EMC requirements” are still in the **ECSS-E-ST-20C, Ch. 6**

# ECSS-E-ST-20-07C Rev. 1

## Electromagnetic compatibility

General system requirements are in the ECSS-E-ST-20C, chapter 6

E-ST-20C  
Electrical and  
electronic

- **Key requirement #1** (20C, clause 6.2.1 Overall EMC programme)

HB  
5.1

- *The supplier shall establish an overall EMC programme*
- *The EMC programme shall allow verifying that:*
  - *design and management controls are organised to achieve EMC control*
  - *verification at spacecraft-level is planned and carried out*

- **Key requirement #2** (20C, clause 6.2.2 EMC control plan)

HB  
5.1.  
4

- *As part of the EMC programme, the supplier shall write an EMC control plan ("EMCCP") for the PDR.*
- *The EMC control plan shall apply to every item of equipment and subsystem in the project.*



# ECSS-E-ST-20-07C Rev. 1

## Electromagnetic compatibility

- **Key requirement #3** (20C, clause 6.3.2.2, EMC with the launch system)

E-ST-20C  
Electrical and  
electronic

- *The EM environment seen by the spacecraft ("S/C") & the EMC requirements during pre-launch and launch phases shall be according to applicable launchers user's manuals ("UM")*

*NOTE: Specific EMC requirements during pre-launch & launch phases are in a contractual Interface Control Document established between launcher and S/C.*

- **Key requirement #4** (20-07C, clause 5.3.3 in Ch. 5 Verification)

E-ST-20-07C Rev. 2  
Electromagnetic  
compatibility

- *If the S/C is not powered during launch, EMC testing with the launch system need not be performed.*
- *If the S/C is powered during launch, the E-field RE and RS requirements specified in the Launcher UM, including intentional transmission, shall be verified.*
- *If a S/C RF Tx is operating under fairing, the following shall be verified:*
  1. *EMISM [margin] w.r.t the susceptibility threshold of the EEDs.*
  2. *EMISM w.r.t the spacecraft RF receivers' susceptibility threshold (if operational) or damage threshold (otherwise).*
- *The EMISM between the launch system RF emissions and the spacecraft RF receivers' damage threshold shall be verified.*

HB  
5.3.1.4

HB  
5.3.2.4.1





# ECSS-E-ST-20-07C Rev. 2

## Electromagnetic compatibility

E-ST-20C  
Electrical and  
electronic

- **Key requirement #5** (20C, clause 6.3.5 Intra-system EMC)
  - *The space system shall operate without performance degradation in the electromagnetic environment due to on-board sources (intentional or not).*
- **Key requirement #6** (20-07C, clause 4.2.8 Intra-system EMC)
  - *Intra-system EMC shall be achieved by:*
    - 1. allocation of equipment-level EMI requirements documented in the EMCCP, including:*
      - a) limits on conducted and radiated emission*
      - b) susceptibility test levels*
    - 2. control of conducted and radiated propagation paths, [...]*

E-ST-20-07C Rev. 2  
Electromagnetic  
compatibility

*NOTE: Recommended limits are in Annex A for equipment and subsystems.*

NOTE 1: in the Annex A of the ECSS-E-ST-20-07C Rev. 1, emission and susceptibility limits are **not normative** but **informative**, so part of early project work is to decide on a set of consistent limits.

NOTE 2: it is recommended to identify possible compatibility issues as early as the first half of phase B and to derive ad hoc requirements.

HB  
5.1.  
2

HB  
5.1.  
3

# ECSS-E-ST-20-07C Rev. 1

## Electromagnetic compatibility

Detailed system requirements are in the 20-07C, Ch. 4.2

- **Key requirement #7** (20-07C, clause 4.2.13.2 **Cable shields**)

HB  
5.2.  
4

- a. **Bonding of cable shields shall be as follows:**

- 1. **Bonding to chassis ground is performed at both ends:**

- a) through the equipment connector body,

- b) using backshell that provides for circumferential bonding of shields or using a halo-ring.

- b. **Overshields shall be bonded to chassis ground:**

- 1. **at both ends,**

- 2. **using a 360° direct contact.**

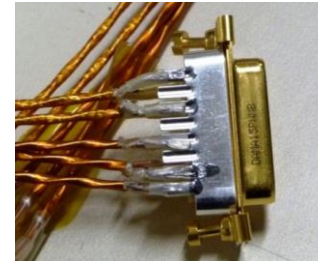
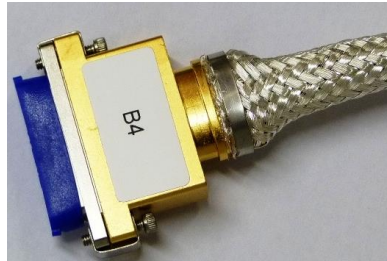

# ECSS-E-ST-20-07C Rev. 1

## Electromagnetic compatibility

Equipment and subsystem level EMC test procedures [methods] are specified in the 20-07C, chapter **5.4**

HB  
4

Limits in the 20-07C are informative | **Test methods are normative**

HB  
5.1.2.  
3

Informative limit Annex A	Title of test procedure	Verification Clause 5
A.2	CE on power leads, differential mode, 30 Hz to 100 kHz (1st part)	5.4.2
A.2	CE on power leads, differential mode, 100 kHz to 100 MHz (2nd part)	5.4.3
A.3	CE on power leads, in-rush currents	5.4.4
A.4	CE on power and signal leads, common mode, 50 kHz to 100 MHz	5.4.3
A.6	DC magnetic field emission	5.4.5
A.7	RE, low-frequency magnetic field	Specific
A.8	RE, low-frequency electric field	Specific
A.9	RE, electric field, 30 MHz to 18 GHz	5.4.6
A.10	CS, power leads, differential mode, 30 Hz to 100 kHz	5.4.7
A.11	CS, power and signal leads, common mode, 50 kHz to 100 MHz	5.4.8
A.12	CS, power leads, short spike transients	5.4.9
A.13	RS, magnetic field, 30 Hz to 100 kHz	5.4.10
A.14	RS, electric field, 30 MHz to 18 GHz	5.4.11
A.15	Susceptibility to wire-coupled electrostatic discharges (legacy method)	5.4.12

Table updated  
in ECSS-E-ST-  
20-07C Rev. 2

# ECSS-E-ST-20-07C Rev. 1

## Electromagnetic compatibility

- For the qualification of equipment, Emission & Susceptibility **limits** in the 20-07C are only informative (contrary to the test methods that are **normative**), so they all have to be defined.
- It is always necessary to tailor RE and RS requirements to the characteristics of **RF transmitters and receivers** on-board:
  - RE requirements to the frequency band of RF receivers, and to the maximum acceptable interference level (HB 5.1.3.2.2.a)
  - RS requirements to the frequency band of RF transmitters, and to the transmitted power level (HB 5.1.3.2.2.b)

HB  
5.1.  
2

HB  
5.1.  
3

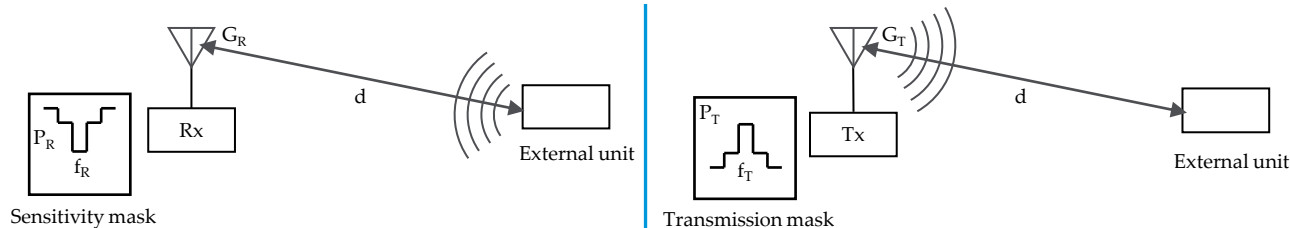

# ECSS-E-ST-20-07C Rev. 1

## Electromagnetic compatibility

### Tailoring and apportioning of DC magnetic requirements

- Design AND verification methods have to be specified as part of a **magnetic cleanliness** programme
- Magnetic moment requirements are apportioned according to:
  - Equipment **location**
  - Equipment **size**
  - **Technology**

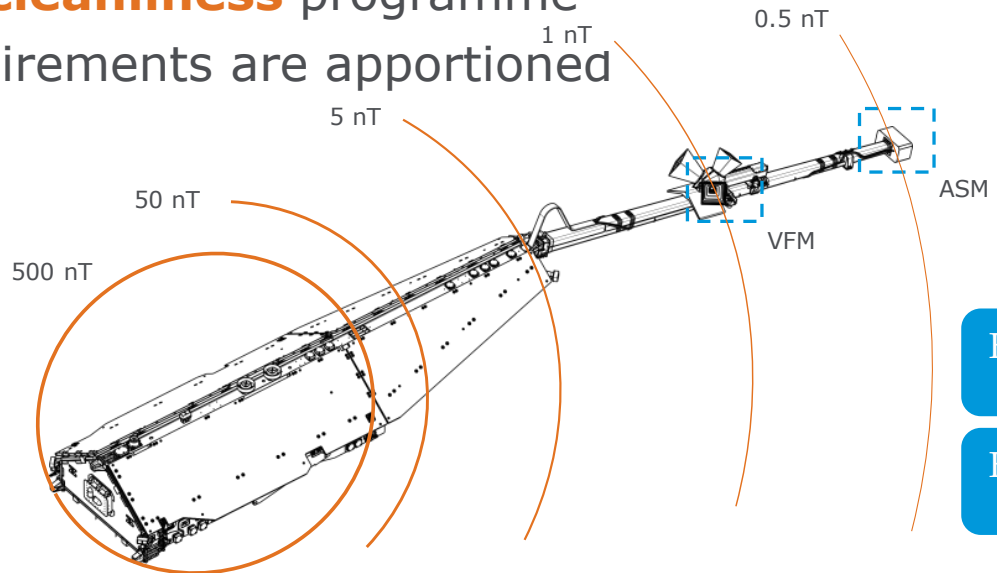

E-ST-20-07C Rev. 2  
Electromagnetic  
compatibility

HB  
6.2

HB  
7.1

# **ECSS E-ST-20-08C Rev. 1**

## **Photovoltaic Assemblies and Components**

TEC-EPG  
ESTEC  
27/11/2012

# ECSS-E-ST-20-08C Rev. 1 General

- This Standard outlines the requirements for the **qualification, procurement, storage and delivery** of the **main assemblies and components** of the space **solar array electrical layout**: photovoltaic assemblies, solar cell assemblies, bare solar cells, coverglass and protection diodes.
- This standard **does not** cover the particular **qualification** requirements for a **specific mission**.
- Rules for the flow of technical requirements from a project solar array specification are defined **down to component level** to guarantee that lower-level components and sub-assemblies are qualified according to specifications.
- On the other hand, the qualification of a specific level of assembly is based on the use of qualified components and sub-assemblies at lower levels.
- Therefore, the qualification programme assures that the specific sub-assembly or component meets the requirements defined for a particular application.
- Engineering and qualification requirements **at higher solar array integration levels** (panels & wings) are specified in ECSS-E-ST-20C and ECSS-E-ST-10-03C.

# PVA - Photovoltaic Assembly Qual. Level

The Photo Voltaic Assembly (**PVA**) coupon is the power generating network, which includes **all electrical components**, integrated **on a flight representative solar array substrate**.

PVA coupons shall be submitted to the following qualification programme to demonstrate:

**Fatigue Thermal cycling**: The life fatigue compatibility of all electrical connections between the different components. Includes Thermal Vacuum (TV) and Ambient Pressure Thermal Cycling testing (APTC).

**Long term storage**: The endurance in a real-life environment against standard environmental conditions using accelerated tests. Includes Humidity and Temperature testing.

**ESD**: The use of adequate design rules to reduce risk of ESD.

**Four point Bending test**: That the compression and tension stress do not exceed the limits specified for the thermal conditions corresponding to the design dimensioning case.

**Critical points**: Electrical network stability under TV, definition of APTC temperature profile & number of cycles and definition of main ESD test parameters (primary discharge duration and S/C and SA capacitances)

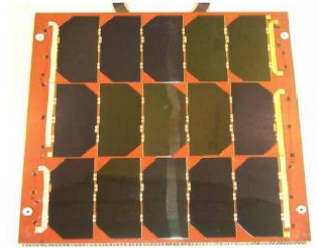

PVA Coupon – Front Side

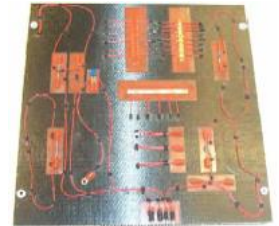

PVA Coupon – Rear Side



# SCA – Solar Cell Assembly Qual. Level

The **SCA** is the assembly of the **bare solar cell**, integrated (welded or soldered) interconnectors and bonded **coverglass** with transparent resin.

SCAs shall be submitted to the following qualification programme to demonstrate:

**Front/rear interconnector adherence**: The interconnectors adherence strength after thermal cycling (Interconnector pull tests)

**BOL performance data and UV exposure**: The solar generator sizing Beginning Of Life performance data and UV exposure compatibility.

**EOL performance data**: The solar generator sizing with End Of Life performance data. (Electron irradiation tests).

**Surface conductivity and humidity**: The SCA surface conductivity stability at EOL (after humidity and electron irradiation tests).

**Life Test**: The SCA power generation stability under worst case operation conditions for long duration.

**Critical points**: UV exposure coverglass glue transmission losses and high fragility of bare cells with front interconnectors to be submitted to pull tests. Activation energy for life test conditions definition

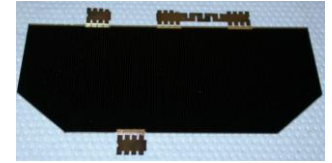

SCA – Front Side



SCA – Rear Side

# Bare Solar Cell Qual. Level

The **bare solar cells** is a semiconductor based component that generates electrical power under illumination.

Bare solar cells shall be submitted to the following qualification programme to demonstrate:

**Front/rear contact adherence**: The interconnector welding/soldering compatibility of the solar cell metallic electrical contacts.

**BOL performance data**: The solar generator sizing Beginning Of Life performance data.

**EOL performance data (Electrons)**: The solar generator sizing End Of Life performance data for mono-energetic electron irradiation doses.

**Extended storage simulation**: The endurance of solar cell coatings and metallic electrical contacts in real-life environment against standard environmental conditions using accelerated tests.

**EOL performance data (Protons)**: The proton radiation damage coefficients or characterize for EOL condition on specific mission.

**Critical points**: Electrical contacts and coatings stability under humidity and solar cells handling (fragile) during testing.

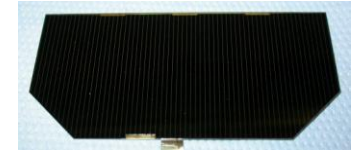

Bare cell – Front Side



Bare cell – Rear Side

# Coverglass Qual. Level

The **coverglass** is a component that protects the solar cell from the space environment. Coverglasses shall be submitted to the following qualification programme to demonstrate:

**Physical characterization of substrate material:** The uncoated glass in air transmission and electro-optical properties.

**Mechanical & BOL performance data characterizations:** The transmission into air and glue, electro-optical, thermo-optical and mechanical properties.

**Coating adherence:** The coating stability under boiling water test.

**Humidity and temperature coating stability:** The extended storage simulation with thermal cycling.

**UV exposure:** The coating stability under UV radiation.

**Electron irradiation:** Coating/glass stability under electron irradiation.

**Proton irradiation:** Coating/glass stability under proton irradiation.

**Breaking strength:** The glass strength to breakage.

**Critical points:** Coatings stability under humidity and UV exposure and coverglass handling (fragile) during testing.



Coverglass ready for thermal cycling test

# Solar cell protection diode Qual. Level

The protection diode is a component that connected in anti-parallel to the cell prevents electrical cell operation in reverse mode. Integral protection diodes (IPDs) are part of the solar cell structure and External Protection Diode (EPDs) are a separate component.

Protection diodes shall be submitted to the following qualification programme to demonstrate:

**Electron irradiation and switching**: stability under EOL conditions and robustness against electrical transients on ground and in-orbit.

**Extended storage simulation**: The endurance of metallic electrical contacts in real-life environment against standard environmental conditions using accelerated tests.

**Contact adherence and ESD**: The interconnector welding/soldering compatibility of the diode contacts and robustness against human body electrostatic discharges.

**Life Test**: The stability under worst case operation for long duration. For IPDs some of these tests are done at bare or SCA level.

**Critical points**: Diode of activation energy for life test conditions definition. Acceptance test electrical requirements.

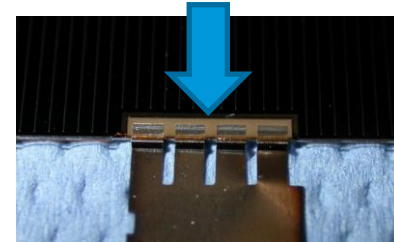

IPD Integral protection diode, with interconnector.

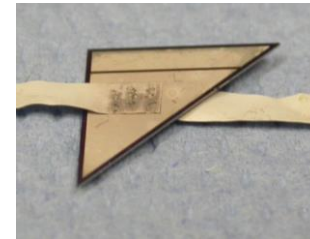

EPD External protection diode, with interconnector.

# ECSS E 20 series tutorial, conclusions

The E 20 STD's have been briefly presented.

- **Key principles and definitions,**
- **key categories of requirements,**
- **some of the key requirements and some hints on tailoring**

have been presented, together with the basic ideas that inspired the E 20 STD's chapters and the relevant requirements.

For more details and for support on the utilisation of the STD's, please refer to ESA-ESTEC

- **TEC-EP division (power systems) and specifically**
  - **TEC-EPG for power generators (solar arrays)**
  - **TEC-EPB for energy (electrochemical) storage**
  - **TEC-EPM for power management and distribution (electrical and electronics)**
- **TEC-EPS for space environment and effects (spacecraft charging)**
- **TEC-EPE for electromagnetic compatibility**

# ECSS E 20 series tutorial, conclusions

**Thanks for the attention!**

**I wanted specially to thank Evelyne Simon (ex TEC-EPB) and Stephen Taylor, Emilio Fernandez Lisbona (TEC-EPG) for their contribution in this presentation**

**Ferdinando Tonicello  
TEC-E, Electrical Lead Engineer  
[Ferdinando.Tonicello@esa.int](mailto:Ferdinando.Tonicello@esa.int)  
Tel. +31.71.565.5442**

# ECSS E 20 series tutorial, acronym list

<b>APR</b>	Array Power Regulator	<b>EPD</b>	External Power Diode	<b>Pyro</b>	Pyrotechnic (device)
<b>APTC</b>	Ambient Pressure Temperature Cycling	<b>EPS</b>	Electrical Power System	<b>R&amp;D</b>	Research & Development
<b>ASM</b>	Absolute Scalar Magnetometer (SWARM satellite)	<b>ESA</b>	European Space Agency	<b>RE</b>	Radiated Emission
<b>BATT</b>	Battery	<b>ESD</b>	Electro Static Discharge	<b>RF</b>	Radio Frequency
<b>BCDR</b>	Battery Charge and Discharge Regulator	<b>FF</b>	Fill Form	<b>RLCL</b>	Retriggerable Latching Current Limiter
<b>BCR</b>	Battery Charge Regulator	<b>GEO</b>	Geostationary Earth Orbit	<b>RS</b>	Radiated Susceptibility
<b>BDR</b>	Battery Discharge Regulator	<b>HPC</b>	High Power Command	<b>S/C</b>	Spacecraft
<b>BOL</b>	Beginning Of Life	<b>HV</b>	High Voltage	<b>S3R</b>	Serial and Sequential Shunt Regulator
<b>CDMU</b>	Central Data Management Unit	<b>I/F</b>	Interface	<b>SA</b>	Solar Array
<b>CE</b>	Conducted Emission	<b>IPD</b>	Internal Protection Diode	<b>SAR</b>	Solar Array Regulator
<b>CM</b>	Command Module	<b>LCL</b>	Latching Current Limiter	<b>SCA</b>	Solar Cell Assembly
<b>CS</b>	Conducted Susceptibility	<b>LEO</b>	Low Earth Orbit	<b>SEE</b>	Single Event Effect
<b>DOD</b>	Depth Of Discharge	<b>LEOP</b>	Low Earth Orbit Phase	<b>SPFF</b>	Single Point Failure Free
<b>DPFF</b>	Dual Point Failure Free	<b>MEA</b>	Main Error Amplifier	<b>SPIS</b>	Spacecraft Plasma Interaction Software
<b>ECSS</b>	European Cooperation for Space Standardization	<b>MEO</b>	Medium Earth Orbit	<b>SRS</b>	System Requirement Specification
<b>EED</b>	Electro Explosive Device	<b>MRD</b>	Mission Requirement Document	<b>STD</b>	Standard
<b>EEE</b>	Electrical, Electronic, and Electro-mechanical	<b>OBDDH</b>	On Board Data Handling	<b>TV</b>	Thermal Vacuum
<b>EMC</b>	Electro Magnetic Compatibility	<b>PCDU</b>	Power Control and Distribution Unit	<b>UM</b>	User Manual
<b>EMCCP</b>	Electro Magnetic Compatibility Control Plan	<b>PD</b>	Power Distribution	<b>UV</b>	Undervoltage
<b>EMI</b>	Electro Magnetic Interference	<b>PEO</b>	Polar Earth Orbit	<b>VFM</b>	Vector Field Magnetometer (SWARM satellite)
<b>EMISM</b>	Electro Magnetic Interference Safety Margin	<b>PTC</b>	Positive Temperature Coefficient (resistor)		
<b>EOL</b>	End Of Life	<b>PVA</b>	Photo Voltaic Assembly		

The material produced for ECSS Training and Learning Programme is property of the European Space Agency (ESA) or ESA's licensors. No part of this material may be reproduced, displayed, amended, distributed or otherwise used in any form or by any means, without written permission of ESA or ESA's licensors. Any unauthorised activity or use shall be an infringement of ESA's or ESA licensors' intellectual property rights and ESA reserves the right to defend its rights and interests, including to seek for remedies.





European Cooperation for  
Space Standardization

