

Standardization training program E-60 discipline: Control

Satellite AOCS requirements
ECSS-E-ST-60-30C (Aug 2013)

The ECSS E60 branch

Standardization
training program
E60 discipline:
Control

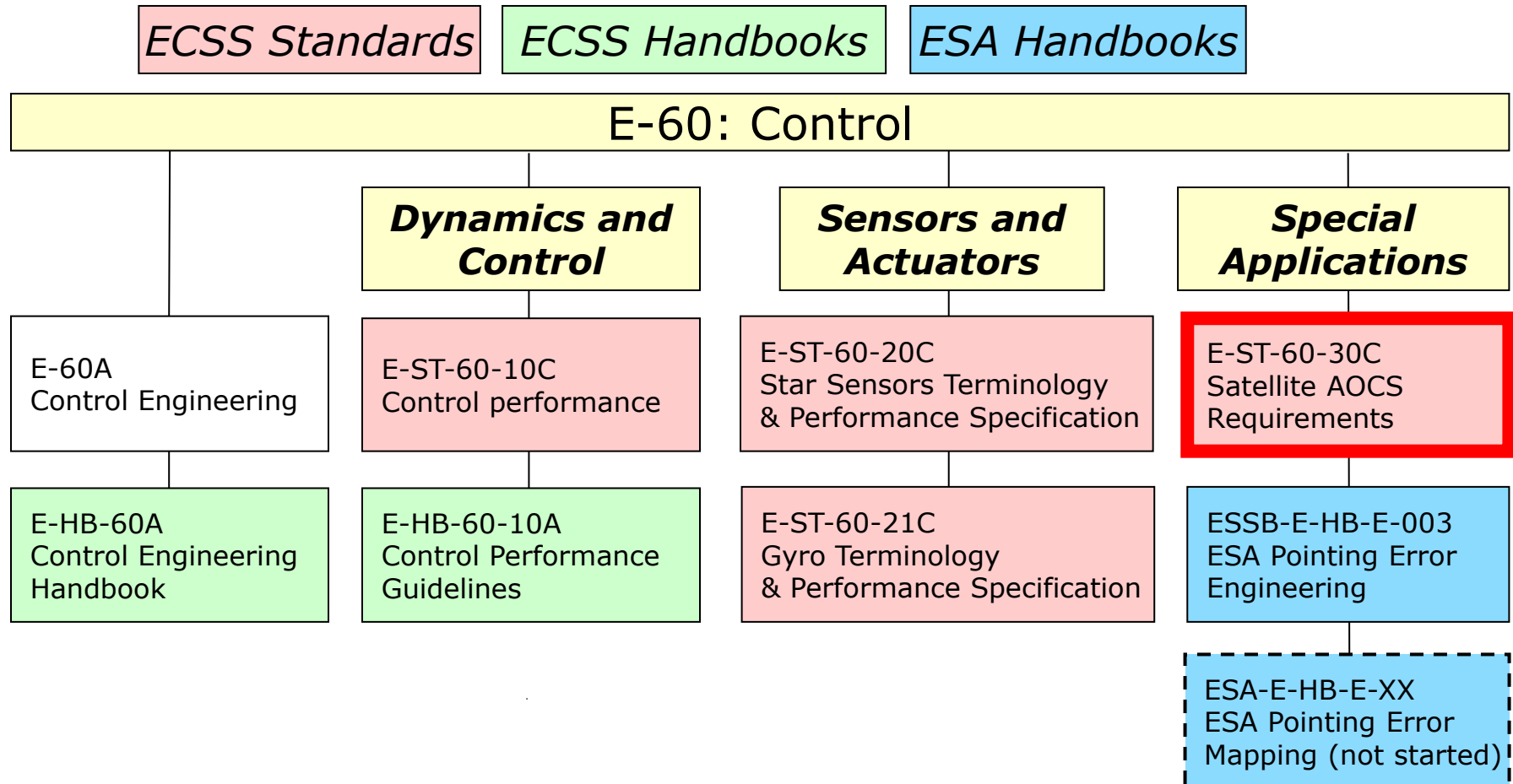

Attitude and Orbit Control System Functions

Standardization
training program
E60 discipline:
Control

- The AOCS performs the following functions:
 - Attitude (and position) **estimation** based on sensors measurements and processing
 - **Attitude control** using actuators (torques)
 - **Orbit corrections** with actuators (forces)
- With a high level of **autonomy**:
 - Initialisation without ground intervention
 - Automatic closed loop control: command = feedback (attitude, rate)
 - Autonomous management of modes
 - Failure Detection, Isolation and Recovery
- Throughout the various mission phases:
 - Launch & Early Orbit Phases
 - Operational phase
 - FDIR and Reacquisition
 - Disposal

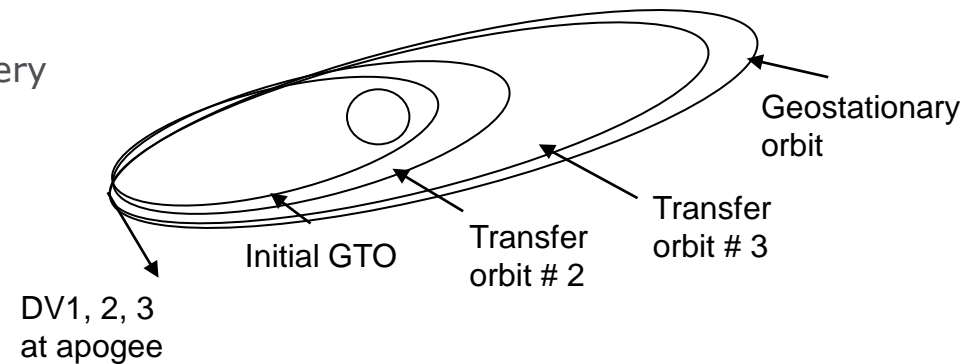
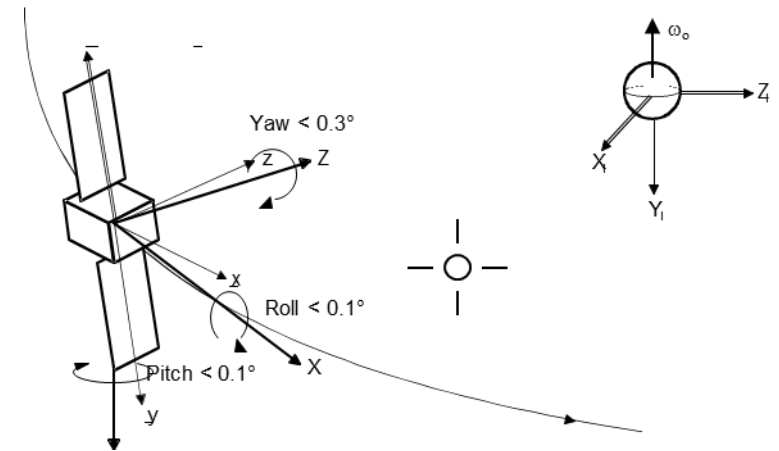

Typical mission timeline and AOCS modes

Standardization
training program
E60 discipline:
Control

- Launcher separation
 - AOCS units automatic initialisation
- Acquisition Mode
 - Damping of tip-off angular rates
 - Sun acquisition/solar array deployment
- Normal Mode
 - Pointing performance
 - Mission availability
- Orbit Control Mode
 - Delta-V's to reach final orbit
 - Periodic orbit maintenance
- Safe mode
 - Stable state ensuring satellite safety (power, thermal, communications)
 - Minimisation of orbit degradation

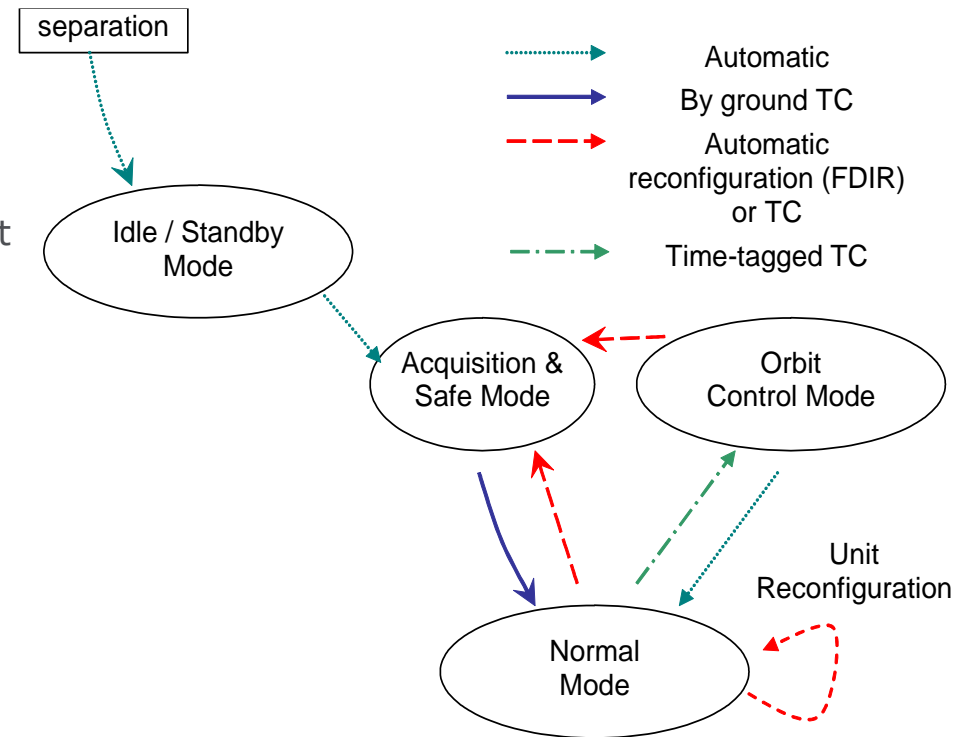

AOCS block diagram

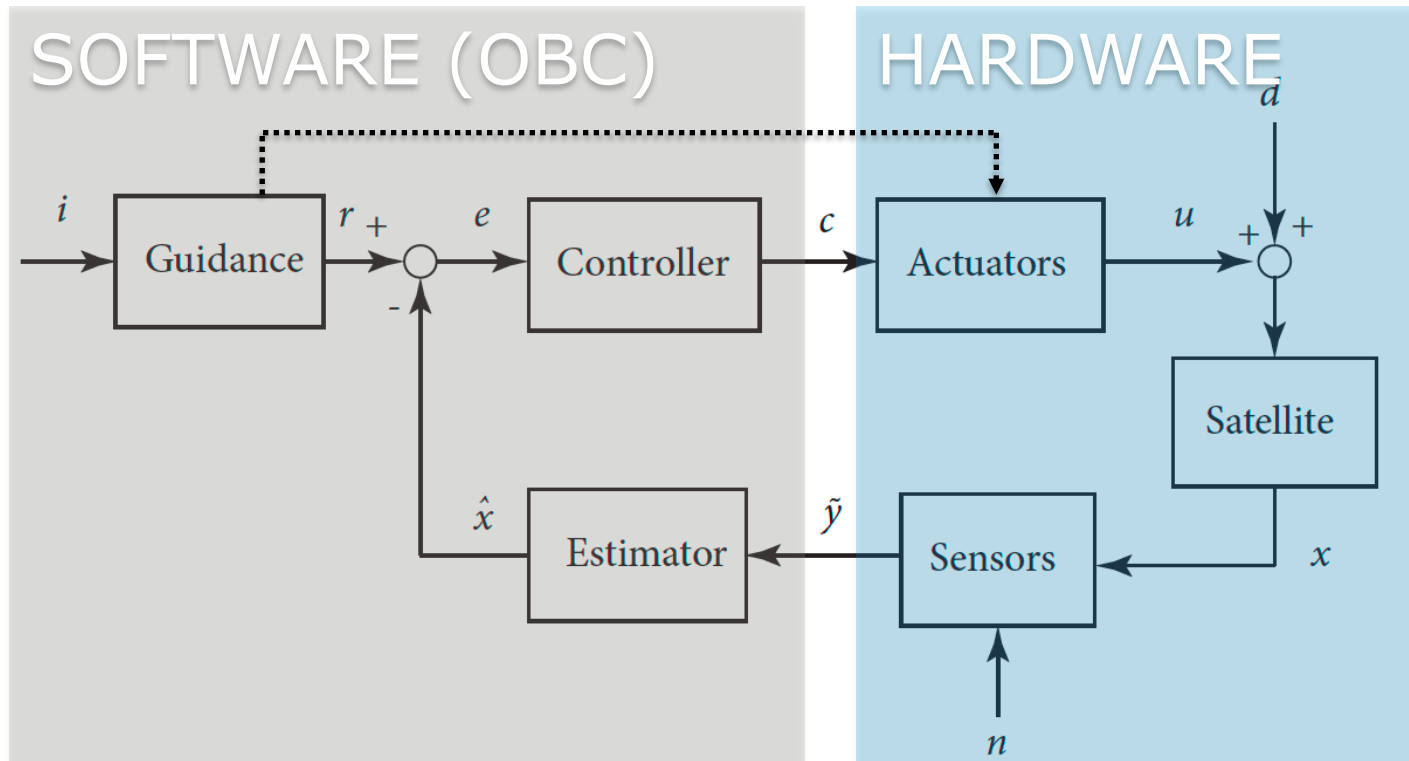

- This document contains a standard set of Attitude and Orbit Control System (AOCS) requirements for the development of satellites
 - It includes all subjects related to AOCS design and verification, namely functions and FDIR, operations, performance, verification and documentation
- Usage
 - A new ESA project will use it (partially) as a standard [catalogue](#) for preparing the relevant sections of the project MRD and SRD
 - The ESA project team will also use it (fully) all along the project development to ensure that the mandatory [AOCS engineering and verification tasks](#) are correctly specified by the prime and properly executed by the prime and its subcontractors
 - In particular, the [normative DRDs](#) in the Annexes will provide a good support for ESA project to obtain proper AOCS documentation
- Variety
 - There is great variation between ESA projects' PRDs, regarding the level of completeness, the level of detail and the expression of similar requirements
 - The distribution of requirements among ESA and industry contractual/technical documentation (e.g. specs and SoW, system and subsystem levels, design and verification, ...) also varies a lot between primes and AOCS companies

- Scope
 - **covers AOCS** attitude estimation, guidance and control; orbit control; and in some cases, on-board orbit estimation
 - **excludes full GNC** with real-time trajectory guidance and control; relative position estimation and control
 - **excludes onboard software**
 - is restricted to AOCS-level requirements, e.g. AOCS pointing performance; and **AOCS FDIR** (excludes system FDIR)
- Tailoring for a specific mission
 - **can leave out** some requirements if not necessary, depending on the industrial organisation, the type of mission and other factors
 - numerical values to be specified (**TBS**) considering each mission's specific needs
 - HW and SW will be a key factor for tailoring of the verification requirements: novelty versus heritage
 - tailoring is made easier thanks to the **numerous notes** embedded in the Standard

Table of contents

Standardization
training program
E60 discipline:
Control

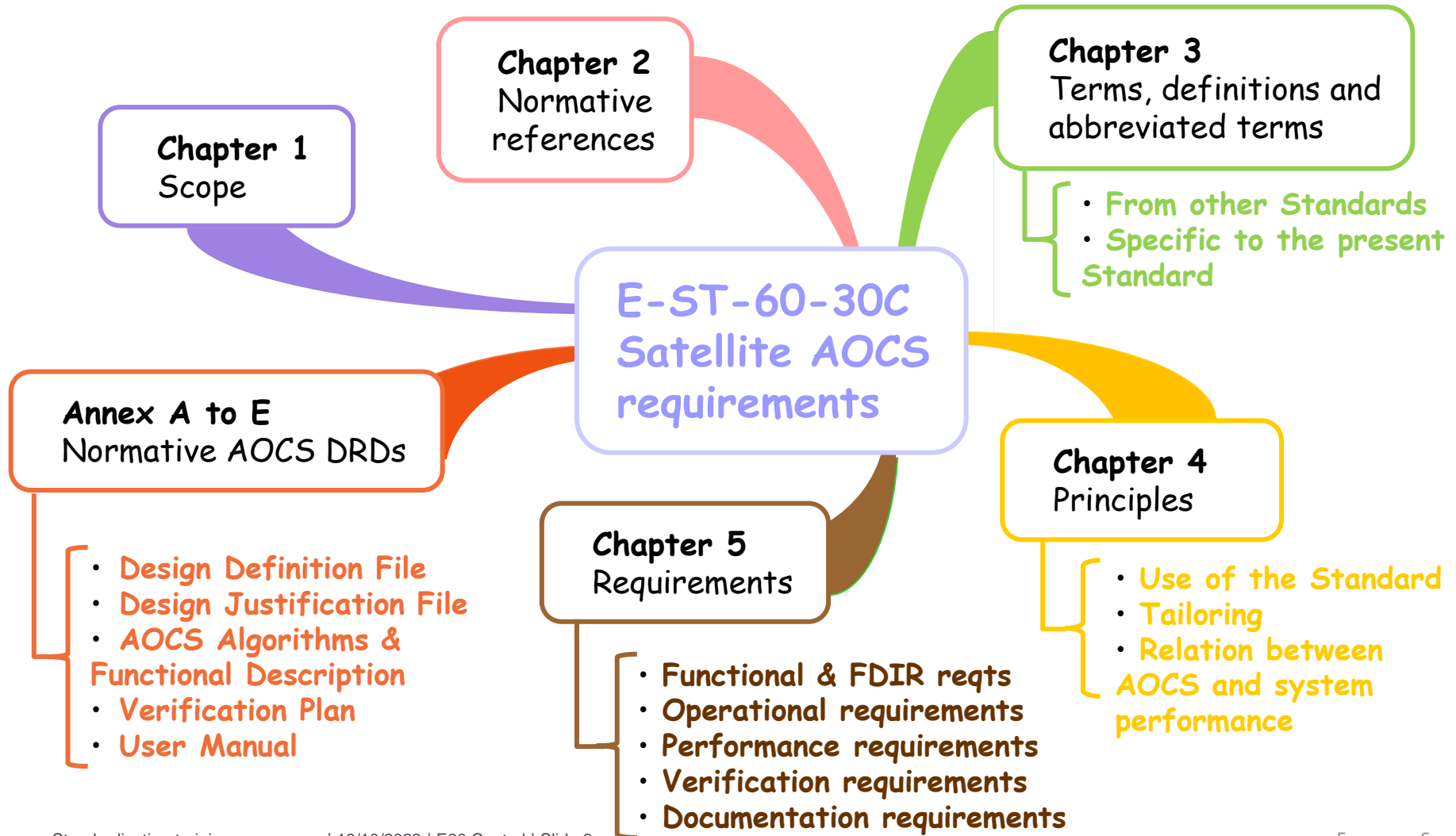

ECSS-E-ST-60-30C: Satellite attitude and orbit control system (AOCS) requirements

Standardization
training program
E60 discipline:
Control

1. Scope
 2. Normative References
 3. Terms, definitions and abbreviated terms
 - 4. Principles - tailoring**
 - 5. Requirements**
- Annex: Design Definition File (DDF) for AOCS – DRD
 - Annex: Design Justification File (DJF) for AOCS – DRD
 - Annex: AOCS algorithms and function description – DRD
 - Annex: Verification plan (VP) for AOCS – DRD
 - Annex User Manual (UM) for AOCS – DRD
 - Annex: AOCS documentation delivery by phase

Chapter 3 overview

Terminology

- Besides terms defined in ECSS-S-ST-00-01 and ECSS-E-ST-10, **specific terms** include
 - Attitude and Orbit Control System (AOCS)
 - AOCS Mode
 - AOCS Functional Simulator
 - Avionics Test Bench
 - End-to-end Tests
 - Flight Dynamics (FD)
 - Guidance, Navigation and Control Functions (GNC)
 - Sensitivity Analysis
 - Worst Case Analysis
- The following **ECSS terms** are defined in ECSS-E-ST-60-10C
 - Absolute Knowledge Error (AKE)
 - Absolute Performance Error (APE)
 - Relative Knowledge Error (RKE)
 - Relative Performance Error (RPE)
 - Robustness

3.2.3 AOCS functional simulator

Fully numerical simulator used to verify the AOCS design, algorithms, parameters and performances

*Note: It can be a collection of unitary numerical simulators, **provided that full coverage of the verification is ensured.***

3.2.8 Sensitivity Analysis

Identification of the parameters which impact the AOCS performance, and assessment of their individual contribution to this performance

Note 1. Only the dominating contributors are of interest. These contributors can include:

- *Noise, bias, misalignment for the AOCS sensors and actuators*
- *Satellite mass properties*
- *Satellite configuration variation, e.g. solar array position, sensors and actuators configuration*
- *Measurements outages*
- *Environmental conditions*
- *External and internal disturbances*

Note 2. The AOCS performance can be for instance: pointing accuracy, duration of a manoeuvre and fuel consumption.

Note 3. The objective is to have an order of magnitude of the contribution, and this can be achieved by analysis, simulation or test.

- Purpose
 - This Standard gathers together typical AOCS requirements for use in the Project Requirement Documents (**PRD**) and the AOCS technical specification, for space programmes at all levels of the customer-supplier chain above AOCS.
- Applicability
 - It is applied **by the highest level customer (e.g. ESA, CNES, DLR etc.) to the prime contractor**, for instance through the MRD or SRD
 - It is **not directly applicable to the AOCS contractor**, whose contractual specification document is a PRD derived from this Standard
- Generality
 - Because of the large variety of space missions, AOCS functions and AOCS performances, the typical AOCS requirements need to be tailored for a dedicated mission. Tailoring needs experience and pragmatism, must read the notes, cannot just cut & paste.
 - The numerical values for performance requirements are expected to be specified (TBS), for each specific project.
- Level
 - It is important to distinguish between AOCS level and system level (i.e. satellite, project, mission or programme).
- The notes
 - These help to decide which requirement to include and how to adapt it for the dedicated mission.
 - EXAMPLE: If a mission requires an onboard navigation function, then requirements dedicated to this function or to an on-board GNSS receiver are applicable.

Chapter 5

Requirements - Overview

A Standard providing a comprehensive template for AOCS requirements specification, covering all project phases, gathered into **5 major** groups

5.2 Operational requirements

- TM/TC, ground monitoring
- Autonomy
- Calibration operations

5.3 Performance requirements

- Domains definition
- Pointing and knowledge performance
- Agility, outages
- Non nominal modes (safety, orbit control)

5.1 Functional and FDIR requirements

- Modes and functions
- System constraints
- FDIR and redundancy

5.4 Verification requirements

- Verification facilities (simulators and benches)
- HW/SW verification
- Verification at satellite level and in flight

5.5 Documentation requirements

- Typical documents per phase
- Required documents

Chapter 5.1 contents

Functional and FDIR requirements

Standardization
training program
E60 discipline:
Control

- General functional requirements
 - High level functions
 - Attitude acquisition and keeping
 - Attitude determination
 - Navigation
 - Reference frames
 - Mission pointing
 - Calibration requirements on AOCS
- Fault management requirements
 - Basic FDIR requirements
 - Hardware and software redundancy scheme
- Propulsion related functional requirements
 - Utilization constraints
 - Fuel gauging
 - Fuel sizing
 - Thruster qualification

5.1.1.8 Safe mode

- a. *In case of major anomaly, the AOCS shall provide the capability to autonomously reach and control safe pointing attitude and angular rates to ensure the integrity of the spacecraft vital functions, including power, thermal and communications.*

NOTE 1. Depending on satellite design and operational sequences, the Safe pointing attitude can be required to be compatible with several satellite mechanical configurations corresponding to solar arrays and appendages in stowed, partially deployed or fully deployed configurations.

NOTE 2. Major anomalies are defined programme by programme.

Chapter 5.1 example 2

AOCS FDIR requirement evolution

- Earlier ESA projects always expressed strict design implementation requirements for FDIR and Safe Mode, e.g.



*R-AOCS-0180 The Emergency and Safe Mode [ESM] **shall use Actuators and Sensors different** from those used in nominal Operational Mode*

- Recent ESA projects tend to be more open
- The Standard “Satellite AOCS requirements” (ECSS-E-ST-60-30C) will not impose a strict upfront architectural design:

5.1.2.2 Hardware and software redundancy scheme

- a. The AOCS shall justify the hardware redundancy implemented against failure tolerance requirements and reliability requirements.*
- b. The AOCS **shall justify the design** of the safe mode against the risk of common design error and common failure with the modes used for the nominal mission.*

Chapter 5.2 contents

Operational requirements

Standardization
training program
E60 discipline:
Control

- Requirements for ground TC
 - Requirements for parameters update
 - Orbit control manoeuvres
 - Orbit determination
 - Attitude guidance
- Requirements for TM
 - AOCS needs ground monitoring
 - Housekeeping TM
 - Diagnostic and event TM
- Requirements for autonomous operations
 - AOCS autonomy
 - Safe mode
- Requirement for calibration operations

Chapter 5.2 example

Operational requirements

Standardization
training program
E60 discipline:
Control

- *Upon ground request, the flight software shall provide the capability for **in-flight update** of the AOCS design **parameters**, through a generic service using a logical addressing.*
 - *NOTE: The AOCS design parameters are not supposed to be modified in flight, but can be changed if necessary. They include filter coefficients, control law gains and parameters involved in transition criteria.*



Chapter 5.3 contents

Performance requirements

- Flight domain
- Normal mode
 - Overview
 - Absolute attitude pointing (APE class)
 - On-board absolute attitude knowledge (AKE class)
 - A posteriori absolute attitude knowledge (AKE class)
 - Relative attitude pointing (RPE class)
 - A posteriori relative pointing knowledge (RKE class)
- Orbit knowledge and orbit control
 - Orbit knowledge (AKE class)
 - Orbit control
- Attitude agility
- Performances outages
- Acquisition and safe mode
- Performance budgets

Chapter 5.3 example

Performance requirements

5.3.3.2 Orbit Control

a. *The AOCS shall perform the Delta-V commanded by the ground for the orbit control with an accuracy better than:*

- 1. TBS % of the Delta-V magnitude along the commanded direction,*
- 2. TBS % of the Delta-V magnitude on the perpendicular directions (**parasitic impulses**).*

NOTE 1. This requirement is valid when the delta-V magnitude is commanded from ground and executed onboard with a closed loop control of the magnitude.

NOTE 2. This requirement can not be used in the following cases:

- Case of an autonomous orbit control, where performances are described with respect to the reference orbit.*
- Case of Delta-V computed onboard by a position guidance function.*
- Case of a thrust activation profile commanded from ground, with the Delta-V managed on ground.*

NOTE 3. The requirement can be complemented by an absolute threshold (in metres per second) for low Delta-Vs.

NOTE 4. A confidence level can be associated to these requirements.

Chapter 5.3 lesson learnt

ESA project issue at FAR

- ISSUE
 - Missing requirement 5.3.3.2a.2 on parasitic Delta-V
- STATUS
 - Late discovery by ESA reviewers: **missing parasitic Delta-V specification** detrimental to operations, for nominal manoeuvre planning and also for safe mode
 - Correction would incur additional delays and costs
 - The question was how to demonstrate compliance. Monte Carlo would need a large number of simulations (>>100), unless a worst case justification could be accepted together with a limited number of test runs
- WORK AROUND SOLUTIONS
 - ESOC to urgently consolidate acceptable requirements on parasitic Delta-V
 - ESA and Contractor to formally agree on this
 - Contractor to demonstrate full AOCS compliance to parasitic Delta-V requirements by analysis complemented by a simulation campaign
 - Contractor to produce a TN on parasitic Delta-V, incorporated in the requirements baseline, properly verified and included in all AOCS documentation

Chapter 5.4 contents

Verification requirements

Standardization
training program
E60 discipline:
Control

- Verification facilities
- AOCS design and performance verification
- AOCS hardware/software verification
- Verification at satellite level
- AOCS-ground interface verification
- In flight verification

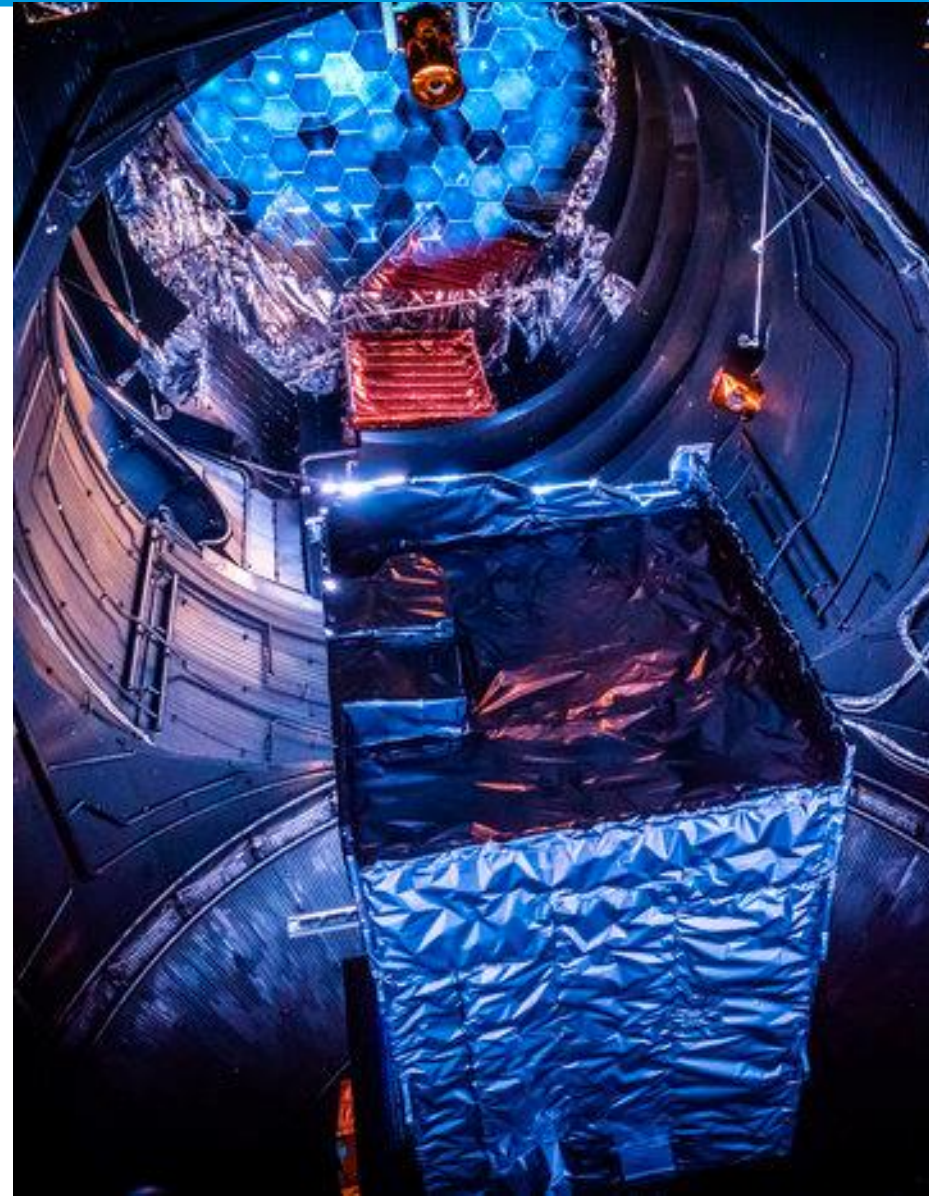

Chapter 5.4 scope

Verification

| inside scope | outside scope |
|--|--|
| <p>AOCS verification at functional chain level. The verification steps used in programmes</p> <p>NB As there are too many situations, a standard process is not described in order to allow flexibility. Requirements are specified to be included in a company's own V&V process.</p> | <p>A complete list of testing facilities (see E-TM-10-21 for some)</p> |
| <p>Verification process of the software specification w.r.t. AOCS functional needs (see Clauses 5.4.3b & 5.4.5)</p> | <p>Verification process of software conformance w.r.t. its specifications (see E-ST-40C)</p> |
| <p>Verification process of the AOCS functional chain, taking into account real behaviour of equipment issued from the equipment verification process (see Clause 5.4.5)</p> | <p>Verification process of the conformance of equipment (AOCS units) w.r.t. their specifications (see E-ST-10-03C; E-ST-20C; E-ST-50-12C; and the ECSS-Q series)</p> |
| <p>Polarity testing (see Clause 5.4.6b)</p> | <p>Satellite integration verification (see E-ST-10-03C)</p> |
| | <p>Environmental testing (see E-ST-10-03C)</p> |

Chapter 5.4 example

Verification requirements

Standardization
training program
E60 discipline:
Control

5.4.4 AOCS design and performance verification

- a. The AOCS design and performance verification shall be performed through **theoretical analyses** and **numerical simulations** on the AOCS functional simulator.*

- b. The AOCS design and performance verification shall cover **all the AOCS modes, functions and mode transitions**.*

Chapter 5.4 example

Verification requirements

5.4.3 Verification facilities

a. The AOCS functional simulator shall be representative of:

1. all the AOCS functions and states;
2. the algorithms specified for the on-board software, or directly implemented in hardware;
3. the AOCS equipment behaviour and performances;
4. the satellite dynamics and kinematics;
5. the space environment related to the dynamic evolution of the attitude and possibly the position, depending on the mission.

Note 1. This representativity includes an adequate modelling of the delays, jitters, and sampling rates of the AOCS loop.

Note 2. It is recommended to include in the simulator the representativity of the failure detection algorithms or function.

Note 3. A good way to ensure the representativity of the algorithms is to reuse the source code of the flight AOCS application software.

Note 4. The representativity of the position evolution (6 degree of freedom simulator) is useful for instance for Drag Free missions.

b. The **simulation models** of the AOCS sensors and actuators implemented respectively in the AOCS functional simulator and in the Avionics test bench shall be **validated** with respect to the real hardware behaviour.

Note A good way is to perform a correlation between sensors and actuators simulation models and hardware test results.

c. The simulation models used in the AOCS functional simulator or the avionics test bench for dynamics effects shall be justified.

Note Dynamic effects can arise from thermal snap, liquid sloshing and flexible modes of appendages.

d. The avionics test bench shall include a hardware model of the on-board computer functionally representative of the flight model.

Note Consequently, the numerical precision of the onboard computer is represented and is compared to analysis or simulations performed during the AOCS development process.

e. The avionics test bench shall embed the real flight software.

f. It shall be possible to introduce a simulation of the forces and torques generated by the AOCS actuators in the dynamics model of the avionics test bench.

g. The avionics test bench shall be representative of real hardware interfaces.

h. The avionics test bench shall be representative of the real time behaviour.

NOTE: The requirements on the avionics test bench define the features necessary on this bench when it is used for the hardware/software verification. Other solutions are however possible as mentioned in the clause 5.4.5.

Chapter 5.5 overview

AOCS Documentation

- Typical AOCS documentation versus development phase
- Formalised normative DRDs (document requirements definition) provided in annexes

| Subject | Availability | | | | Comments |
|--|---------------|-------------|-------------|----|---|
| | Phase A (end) | PDR | CDR | QR | |
| AOCS Technical Specification | ✓ | ✓ | | | Can be part of Platform level specification DRD in ECSS-E-ST-10-06 Annex A |
| Design Definition File for AOCS | Preliminary | ✓ | ✓ | ✓ | DRD in Annex A |
| AOCS Algorithms and Functional Description | | ✓(part) | ✓ | | DRD in Annex C |
| AOCS Hardware Units Specifications | | ✓ | | | DRD in ECSS-E-ST-10-06 Annex A |
| Design Justification File for AOCS | | Preliminary | ✓ | ✓ | DRD in Annex B |
| Verification Plan for AOCS | | Preliminary | ✓ | | DRD in Annex D |
| AOCS Simulation Plans | | | ✓ | | |
| AOCS Test Plans | | | ✓ | | DRD in ECSS-E-ST-10-03 Annex A for satellite tests |
| AOCS Simulation Results Reports | | | ✓ | ✓ | |
| AOCS Test Reports | | | ✓ (part) | ✓ | DRD in ECSS-E-ST-10-02 Annex C |
| AOCS Budgets | Preliminary | ✓ | ✓ | ✓ | Refer to ECSS-E-ST-60-10 for performance budgets |
| AOCS Software Parameters | | | ✓ | ✓ | |
| User Manual (AOCS part) | | | Preliminary | ✓ | DRD in Annex E |

Annexes A-E normative DRDs

Standardization
training program
E60 discipline:
Control

| annex | | DRD |
|-------|-----------|--|
| A | normative | Design Definition File (DDF) for AOCS |
| B | normative | Design Justification File (DJF) for AOCS |
| C | normative | AOCS Algorithms and Functional Description |
| D | normative | Verification Plan (VP) for AOCS |
| E | normative | User Manual (UM) for AOCS |

Design Definition File (DDF) Contents

Standardization
training program
E60 discipline:
Control

Description of the AOCS subsystem: hardware, algorithms and interfaces

- Reference frames and conventions
- Interfaces to ground, payload, FDIR
- Software architecture
- Hardware architecture
- Mode logic
- Per mode: purpose, hardware, algorithms
- TM/TC and FDIR overview
- Hardware information (datasheets, operations, configurations)
- AOCS budgets
- Operational constraints

Design Justification File (DJF) Contents

Standardization
training program
E60 discipline:
Control

Justification of the design, with supporting trade-offs and engineering analyses

- Main design trade-offs and justification
 - Sensor selection and layout justification
 - Actuator selection and sizing
 - FDIR concepts
 - Assumptions, design drivers
- Algorithms justification
 - Control and estimation laws
 - Filtering and processing
 - Parameter tuning (estimation, control, FDIR)
- Performance justification
 - Assumptions, methodology
 - Summary of results

- The E60-30 standard published in 2013 contains a consistent set of Attitude and Orbit Control **System (AOCS) requirements** for the development of satellites
 - It includes all subjects related to AOCS design and verification, namely: functions and FDIR, operations, performance, verification and documentation
- In the ITT preparation phase, it provides a robust set of high level AOCS requirements which can be directly implemented with limited **tailoring** in the ESA MRD/SRD, **limiting the risk of ambiguous or missing or design-oriented requirements**
- In the implementation phase, it helps ESA project team to ensure that AOCS **engineering and verification tasks** are
 - correctly specified by the prime with proper flow down to potential subcontractors,
 - and properly executed by the prime and its AOCS subcontractor.
- Contact point:
 - Benedicte.Girouart@esa.int

- ANY QUESTIONS?