



# Space engineering

## Ranging and Doppler tracking

Published by: ESA Publications Division  
ESA ESTEC, P.O. Box 299  
2200 AG Noordwijk  
The Netherlands

ISSN: 1028-396X

Price: € 10

Printed in: The Netherlands

Copyright: ©2005 by the European Space Agency for the members of ECSS

## Foreword

---

This Standard is one of the series of space standards intended to be applied together for the management, engineering and product assurance in space projects and applications. ECSS is a cooperative effort of the European Space Agency, National Space Agencies and European industry associations for the purpose of developing and maintaining common standards.

Requirements in this Standard are defined in terms of what shall be accomplished, rather than in terms of how to organise and perform the necessary work. This allows existing organisational structures and methods to be applied where they are effective, and for the structures and methods to evolve as necessary without rewriting the standards.

The formulation of this Standard takes into account the existing ISO 9000 family of documents.

This Standard was prepared by the ECSS-E-50-02 Working Group, reviewed by the ECSS Engineering Panel and approved by the ECSS Steering Board.

*(This page is intentionally left blank)*

---

# Contents

---

<b>Foreword</b> .....	<b>3</b>
<b>Introduction</b> .....	<b>7</b>
<b>1 Scope</b> .....	<b>9</b>
<b>2 Normative references</b> .....	<b>11</b>
<b>3 Terms, definitions and abbreviated terms</b> .....	<b>13</b>
3.1. Terms and definitions .....	13
3.2. Abbreviated terms .....	13
<b>4 Requirements</b> .....	<b>15</b>
4.1. Functional .....	15
4.2. Frequency assignment, modulation and spectral sharing.....	20
4.3. Carrier frequency stability .....	26
4.4. Earth station .....	27
4.5. Spacecraft transponder.....	30
4.6. Performance.....	33
<b>5 Compatibility testing</b> .....	<b>37</b>
5.1. General .....	37
5.2. Tests .....	37
A.1 General .....	39
A.2 Category A missions .....	39
A.3 Category B missions.....	40

**Bibliography**..... 45

**Figures**

Figure 1: Ranging and Doppler tracking: functional block diagram..... 16  
Figure 2: Ranging signal spectrum for code length= $2^0$ ..... 22  
Figure 3: Ranging signal spectrum for code length= $2^2$ ..... 23  
Figure 4: Ranging signal spectrum for code length= $2^4$ ..... 23  
Figure 5: Ranging signal spectrum for code length= $2^{12}$ ..... 24  
Figure 6: Carrier frequency stability requirements ..... 26  
Figure C- 1: Integrated Doppler measurement..... 44

## Introduction

---

The purpose of this Standard is to:

- Ensure compatibility between space agencies' spacecraft transponders and the ranging and Doppler tracking facilities of the Earth stations for the Space Operation, Space Research and Earth Exploration Satellite services.
- Ensure, as far as possible, compatibility between space agencies' spacecraft transponders and other networks from which they request support.
- Ensure an adequate level of ranging and Doppler tracking accuracy for missions conforming to this standard.
- Facilitate the early design of flight hardware and ensure that the resulting interfaces and system performances are compatible with given ranging and Doppler tracking configurations and specifications.

*(This page is intentionally left blank)*



# 1

## Scope

---

This Standard is applicable to spacecraft that are supported for ranging or Doppler tracking by direct links to Earth stations<sup>1</sup> and to all related Earth stations operating within the Space Operation, Space Research and Earth Exploration Satellite services<sup>2</sup> as defined in ECSS-E-50-05A Clause 1.

Other space telecommunication services are not covered in this issue.

This Standard applies to projects with unprocessed ranging accuracies<sup>3</sup> of 2,5ns to 30 ns and Doppler tracking accuracies of 0,1 mm/s to 1 mm/s. The analysis of compatibility between systems compliant with this standard and with the CCSDS recommendations is given in Annexes A.2 and A.3.

This document:

- Defines the requirements concerning spacecraft transponder and Earth station equipment for the purposes of ranging and Doppler tracking.
- Provides criteria by which the extent to which the accuracy<sup>4</sup> of the measurements is influenced by equipment effects can be determined.

When viewed from the perspective of a specific project context, the requirements defined in this standard should be tailored to match the genuine requirements of a particular profile and circumstances of a project.

**NOTE:** Tailoring is a process by which individual requirements or specifications, standards and related documents are evaluated and made applicable to a specific project, by selection and, in some exceptional cases, modifications of existing or addition of new requirements.

---

<sup>1</sup> Therefore, this Standard is not applicable for spacecraft supported by data relay satellites.

<sup>2</sup> Therefore, this Standard is not applicable to the Meteorological Satellite service.

<sup>3</sup> For conventional projects with tracking accuracies less stringent than these, CCSDS 401.0-B recommendations may be sufficient.

<sup>4</sup> This accuracy is different to the accuracy of the overall orbit determination process, which is also influenced by effects outside the scope of the standards, i.e. modelling of gravitational and non-gravitational forces, modelling of propagation effects, pre-processing and screening of data.

*(This page is intentionally left blank)*

## 2

## Normative references

---

The following normative documents contain provisions, which, through reference in this text, constitute provisions of this ECSS standard. For dated references, subsequent amendments to, or revisions of, any of these publications do not apply. However, parties to agreements based on this ECSS standard are encouraged to investigate the possibility of applying the most recent editions of the normative documents indicated below. For undated references, the latest edition of the normative document referred to applies.

ECSS-P-001B	ECSS - Glossary of terms
ECSS-E-50A	Space engineering - Communications
ECSS-E-50-05A	Space engineering – Radio frequency and modulation

*(This page is intentionally left blank)*

**3****Terms, definitions and abbreviated terms**

---

**3.1. Terms and definitions**

For the purposes of this document, the terms and definitions given in ECSS-P-001B, ECSS-E-50A and the following apply.

**3.1.1****category A**

category of those spacecraft having an altitude above the Earth's surface of less than  $2 \times 10^6$  km

**3.1.2****category B**

category of those spacecraft having an altitude above the Earth's surface equal to, or greater than,  $2 \times 10^6$  km

**3.2. Abbreviated terms**

The following abbreviated terms are defined and used within this document:

<b>Abbreviation</b>	<b>Meaning</b>
AGC	automatic gain control
AU	astronomical unit
$2B_L$	double-sided phase locked loop noise bandwidth
BPSK	binary phase shift keying (see PSK)
CCSDS	Consultative Committee for Space Data Systems
CLCW	command link control word
C/N	carrier to noise ratio
dB	decibel
dBc	dB with respect to the unmodulated carrier
DRVID	differenced range versus integrated Doppler
IF	intermediate frequency

<b>Abbreviation</b>	<b>Meaning</b>
<b>LO</b>	local oscillator
<b>NRZ</b>	non-return to zero
<b>NRZ-L</b>	NRZ-level
<b>PCM</b>	pulse code modulation
<b>PLL</b>	phase-locked loop
<b>PM</b>	phase modulation
<b>PSK</b>	phase shift keying
<b>pp</b>	peak to peak
<b>RF</b>	radio frequency
<b>r.m.s.</b>	root-mean-square
<b>SNR</b>	signal-to-noise ratio
<b>SPE</b>	static phase error
<b>SP-L</b>	split phase-level
<b>TC</b>	telecommand
<b>TM</b>	telemetry
<b>TR</b>	tracking
<b>UTC</b>	universal time (coordinated)

# 4

## Requirements

---

### 4.1. Functional

#### 4.1.1 Functional breakdown

The ranging and Doppler tracking system is a spacecraft tracking system capable of providing information on the range and range rate between a spacecraft and an Earth station. It uses an active transponder on-board the spacecraft for the re-transmission to the ground of an Earth-to-Space link signal: ranging signal generation and measurement are performed in the Earth station. As a baseline, it is assumed that the spacecraft transponder is used not only for ranging purposes, but also for receiving telecommand signals from Earth and for transmitting telemetry signals to Earth modulated on the same RF carriers. When a transponder is used exclusively for ranging, the requirements in this standard concerning sharing with telecommand and telemetry have no relevance.

A functional breakdown of the ranging and Doppler tracking system is presented in Figure 1. It depicts the five major functions of the system, broken down into functional blocks, as follows:

- the Earth-to-Space link function, employing ground communication <sup>5</sup>, process control, ranging signal generation and Earth-to-Space communication;
- the transponder function, either spacecraft transponder or ground-calibration transponder depending on the application;
- the Space-to-Earth link function, employing Space-to-Earth communication, Doppler measurement, ranging replica generation, ranging correlation, process control and ground communication;
- the link-control function, resident partly in the Space-to-Earth and Earth-to-Space communication and partly in the process control;
- the data-acquisition function, concerned with collection, measurement, processing and transfer of data to the control centre, employing the process-control and the ground communication functions.

The requirements relevant to these five major functions are listed in subclauses 4.1.2 to 4.1.6.

---

<sup>5</sup> Ground communication between the Earth station and the Control Centre is not part of the present standard.

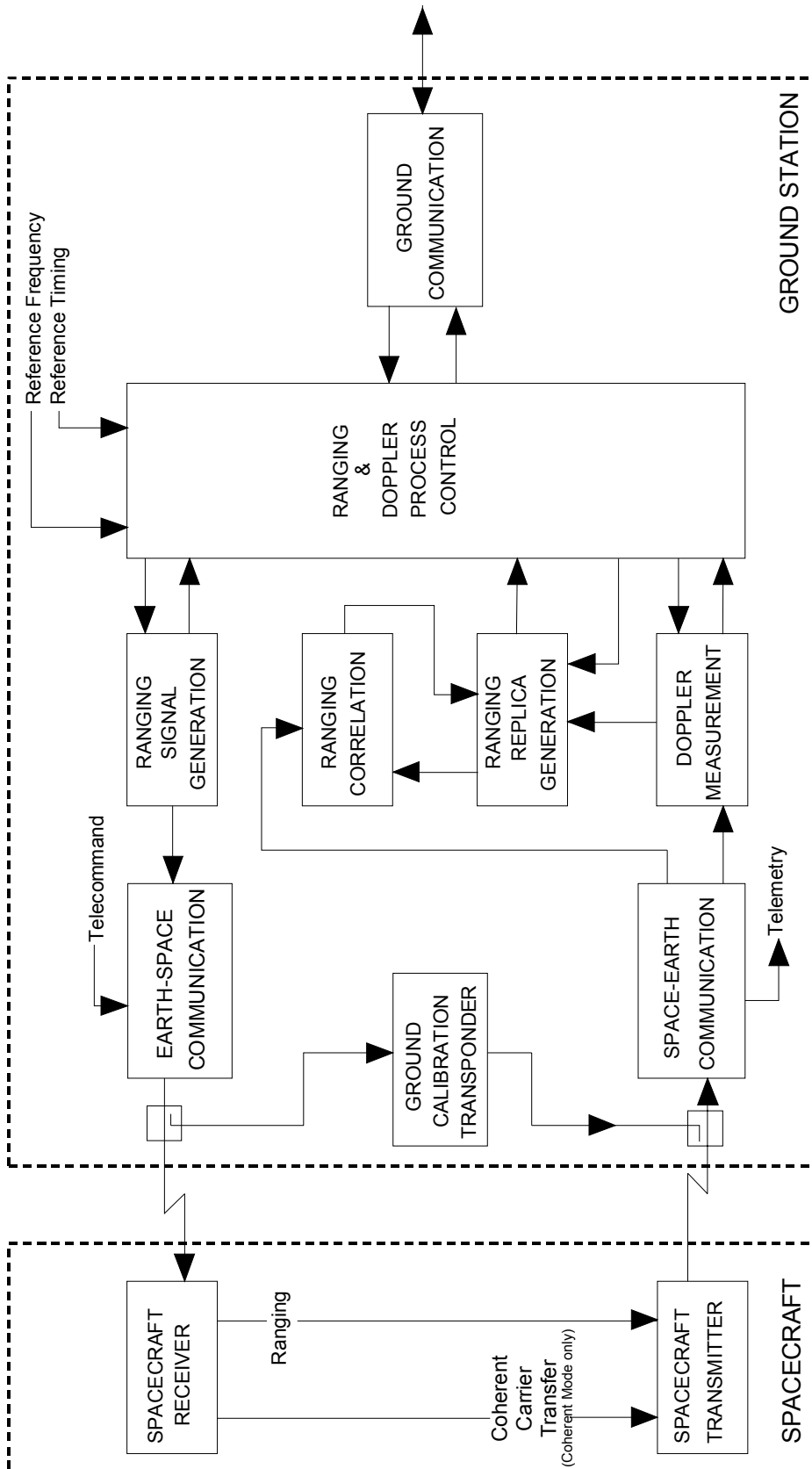

Figure 1: Ranging and Doppler tracking: functional block diagram



## 4.1.2 Earth-to-Space link function

The Earth-to-Space link function shall consist of:

- a. reception of control signals for ranging signal composition (tone frequency, ambiguity resolution code, and modulation index);
- b. generation of the ambiguity resolution code;
- c. generation of the composite ranging signal, consisting of tone and code;
- d. selection of the modulating source, between:
  - ranging,
  - telecommand, and
  - ranging and telecommand;
- e. generation and phase modulation of the first Earth-to-Space link intermediate frequency (IF) carrier;
- f. local oscillator (LO) frequency selection and up-conversion of the modulated IF carrier to the assigned Earth-to-Space link radio frequency (RF);
- g. power amplification of the RF signal;
- h. transmission to spacecraft.

## 4.1.3 Transponder function

### 4.1.3.1 Spacecraft transponder

The spacecraft transponder function shall consist of:

- a. reception of the RF signal;
- b. coherent down-conversion and phase tracking of the residual carrier;
- c. demodulation of ranging and telecommand signals;
- d. independent automatic gain control (AGC) of the residual carrier and base-band signal chains;
- e. in the case of coherent transponders, selection of the Space-to-Earth link frequency source between a local reference (non-coherent mode) and a reference phase locked to the Earth-to-Space carrier (coherent mode);
- f. selection of the modulating source;

NOTE: Modulating source can be selected between:

- ranging (i.e. the demodulated video signal);
  - telemetry;
  - ranging and telemetry;
  - none of the above (for specific missions requiring Doppler measurement of high accuracy, whereby an unmodulated carrier is used).
- g. modulation of the carrier;
  - h. up-conversion of the modulated carrier to the assigned Space-to-Earth link frequency;
  - i. transmission to Earth.

#### 4.1.3.2 Ground calibration transponder

The ground calibration transponder function shall consist of:

- a. frequency conversion of the RF signal from the Earth-to-Space link carrier frequency to the Space-to-Earth link carrier frequency for the purpose of calibrating the ground equipment delay;

**NOTE:** The ranging calibration measurement is usually performed before and after ranging operations with the spacecraft.

- b. frequency conversion of the RF signal from the Earth-to-Space link carrier frequency to the Space-to-Earth link carrier frequency for verification of Earth station phase stability.

#### 4.1.4 Space-to-Earth link function

The Space-to-Earth link function shall consist of:

- a. reception and amplification of the spacecraft signal;
- b. down conversion to an IF band, by means of local oscillators coherent with the station reference frequency or with the Earth receiver phase-locked reference;
- c. phase tracking of the IF signal;
- d. automatic gain control;
- e. reception of telemetry for transponder delay correction, if used <sup>6</sup>;
- f. measurement of integrated Doppler shift on the Space-to-Earth link received or regenerated carrier;
- g. generation of ranging signal replica, taking into account:
  - the frequency and phase information from the integrated Doppler function;
  - the transmitted ambiguity resolution code and the estimated two-way propagation delay towards the spacecraft;
- h. correlation of the generated replica with the received ranging signal;
- i. feedback of filtered correlation signal to the replica generation function for phase alignment of the replica signal with the received signal;
- j. maintenance of ranging signal replica during interruptions of ranging modulation on the Earth-to-Space link (e.g. due to telecommand transmission), by using information from the Doppler function.

**NOTE:** This serves as a time-sharing operation between telecommand and ranging.

---

<sup>6</sup> The following housekeeping information which is embedded in the telemetry data stream, is transmitted for spacecraft control purposes to the Control Centre:  
- Information that enables delay correction of the spacecraft transponder if used for orbit determination;  
- Transponder status for confirmation of relevant control commands and to initiate operational activities (e.g. start of ranging or Doppler operations).

#### 4.1.5 Link control function

The link control function <sup>7</sup> used exclusively for the ranging function shall consist of the code acquisition for ranging, sequentially:

- a. transmission of tone alone;
- b. transmission of the tone modulated with the sequence of codes;
- c. transmission of the tone modulated with the final code <sup>8</sup>.

#### 4.1.6 Data acquisition function

##### 4.1.6.1 Integrated Doppler function

The integrated Doppler function shall consist of:

- a. reception and corresponding acknowledgment of Doppler measurement requests;
- b. pre-processing of Doppler data, in support of the ranging function;
- c. extraction of integrated Doppler data and storage thereof;
- d. integrated Doppler data transfer.

NOTE: For information on integrated Doppler measurements, see Annex C.

##### 4.1.6.2 Ranging function

The ranging function shall consist of:

- a. reception and acknowledgment of ranging initialisation requests;
- b. control for generation of ranging signals and selection between different modes (i.e. deep space, coherent near Earth, non-coherent near Earth);
- c. execution of ambiguity resolution sequence;
- d. execution of ranging measurements by determination of the time interval between the transmitted ranging signal and the replica of the received ranging signal;
- e. storage of ranging data;
- f. ranging data transfer.

##### 4.1.6.3 Meteo function

The meteo function used for correction of tropospheric delay errors when the local meteo model does not meet the project specific accuracy requirements shall consist of:

- a. reception and acknowledgement of meteo data collection requests;

---

<sup>7</sup> The control function concerned with reception and acknowledgment of link parameters, link frequency selection and antenna pointing angles is also used by telemetry and telecommand functions. This is beyond the scope of the present standard.

<sup>8</sup> For certain deep space mission applications, the sequence of codes can be continuously re-started after the final code has been transmitted. The advantage of this scheme is a faster re-acquisition of the ranging signal in case of loss of link at the expense of a reduced accuracy.

- b. measurement of atmospheric pressure, temperature and relative humidity at the Earth station;
- c. storage of meteo data;
- d. meteo data transfer.

## 4.2. Frequency assignment, modulation and spectral sharing

### 4.2.1 Frequency assignment

- a. The ranging and Doppler tracking system shall operate in the frequency bands identified in ECSS-E-50-05A, subclause 4.1.2.
- b. The maximum occupied bandwidth of the ranging signal shall meet ECSS-E-50-05A, subclause 5.4.1.
- c. In order to minimize the occupied bandwidth, the lowest tone frequency compatible with the spacecraft requirements (telecommand, telemetry and ranging) shall be selected.

### 4.2.2 Modulation

#### 4.2.2.1 Modulation schemes

- a. The ranging modulation on both Earth-to-Space and Space-to-Earth links shall be phase modulation (PM).

NOTE: Requirements concerning modulation indexes are stated in subclauses 4.4 and 4.5.

- b. The following two effects shall be considered:
  - 1. power sharing between two or more additive signals, all phase modulated on the same link;
  - 2. interference of the resulting overlying spectra.

#### 4.2.2.2 Ranging signal composition

The ranging baseband signal shall be as follows:

- a. it consists of a sine wave (tone), which is phase modulated by a series of codes, used for ambiguity resolution;
- b. each code is synchronised to the tone such that phase transitions due to the code occur when the unmodulated tone phase is 90°;
- c. the series of codes is described by means of the following expression:

$$C_n = Q_1 \oplus Q_2 \oplus Q_3 \oplus \dots \oplus Q_n$$

where

$C_n$  is the n-th code;

$\oplus$  stands for exclusive or;

$Q_i$  are square waves at frequencies  $2^{-i} \times f_t$ .

- d. Each code is transmitted for a fixed period of time to perform correlation and phase alignment at the receiving site.

- e. The RF carrier is phase modulated with this baseband signal.

**NOTE:** The square waves  $Q_i$  can be generated as the outputs of a divide-by-two flip-flop chain driven by the tone.  
A simple way to generate the code  $C_n$  is to transmit the previous code  $C_{n-1}$  followed by its logical complement.

#### 4.2.2.3 Incompatible modulation schemes

- a. Suppressed carrier modulation schemes as defined in ECSS-E-50-05A subclause 6.2 may be selected for the telemetry.

**NOTE:** Such schemes are not compatible with simultaneous ranging modulation.

- b. If suppressed carrier modulation is selected for telemetry, then the orbit determination shall be supported by one of the following:
- integrated Doppler tracking on the carrier regenerated by the telemetry demodulator;
  - time sharing between suppressed carrier telemetry and ranging;
  - use of a separate ranging transponder.
- c. If the orbit determination is supported by time sharing between suppressed carrier telemetry and ranging (see b. above), the transponder shall be capable of performing the ranging function.

#### 4.2.2.4 Telemetry and ranging

When an optimum choice of tone frequency is established, on the basis of the criteria set out in subclause 4.2.3.2, modulation indexes shall be selected for both signals taking the following into account:

- a. power sharing;
- b. mutual interference;
- c. reduction of the downlink ranging-signal power due to the uplink noise.

#### 4.2.2.5 Telecommand and ranging

- a. Simultaneous ranging and telecommanding should be adopted to avoid scheduling conflicts.
- b. For cases where the link budget constraints are not met for simultaneous ranging and telecommand, ranging and telecommand shall be performed in time sharing.
- c. The following constraints shall be taken into account for simultaneous ranging and telecommanding:
  1. the telecommand signal can appear in the modulated Space-to-Earth link and can create undesirable effects on the transmitted spectrum, owing to power sharing and spectral overlap;
  2. transient overmodulation of the Space-to-Earth link and telemetry signal loss can occur owing to the slow response of the on-board baseband AGC due to the start of telecommand or ranging transmission; this effect can be reduced by:

- (a) ramping the uplink modulation at the start of transmission;
- (b) ensuring the presence of the telecommand signal in the ranging channel before switching the ranging mode on, in case the AGC is active on the telecommand signal.

### 4.2.3 Spectral sharing

#### 4.2.3.1 Ranging spectra

The ranging signal spectrum changes during the ambiguity resolution process, owing to different transmitted codes. The spectrum produced when the tone alone modulates the carrier has discrete lines at the carrier frequency plus or minus integral multiples of the tone frequency (see Figure 2). During the acquisition process, the code number increases and the code power is spread over an increasing number of lines (see Figure 3 and Figure 4). When the last step of the ambiguity resolution is completed, the code has created a quasi-continuous baseband spectrum, which extends (between first nulls) from  $2^{-N} f_t$  to  $(2-2^{-N}) f_t$  where  $f_t$  is the tone frequency, and N is the longest code length (see Figure 5).

**NOTE:** The spectra plotted in Figure 2 to Figure 5 have been obtained with a carrier modulation index of 1,0 rad and with a tone modulation index of  $45^\circ$ . In these figures, the 0-dB reference level corresponds to the modulated carrier power, and  $f_0$  is the carrier frequency.

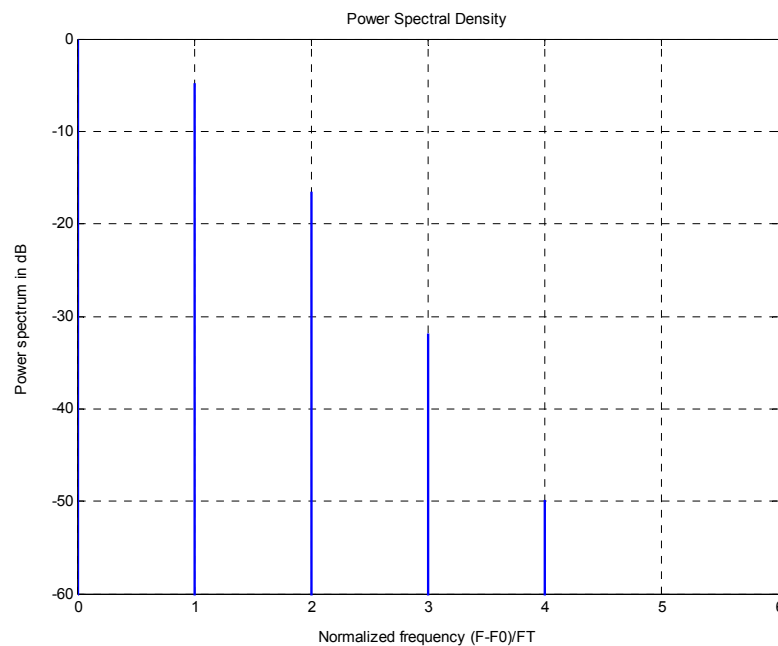

**Figure 2: Ranging signal spectrum for code length =  $2^0$**

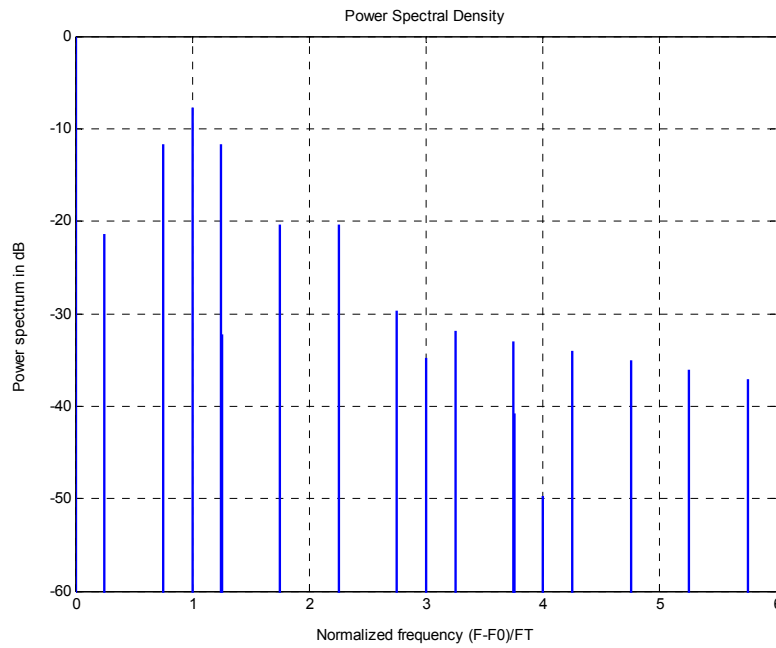

**Figure 3: Ranging signal spectrum for code length =  $2^2$**

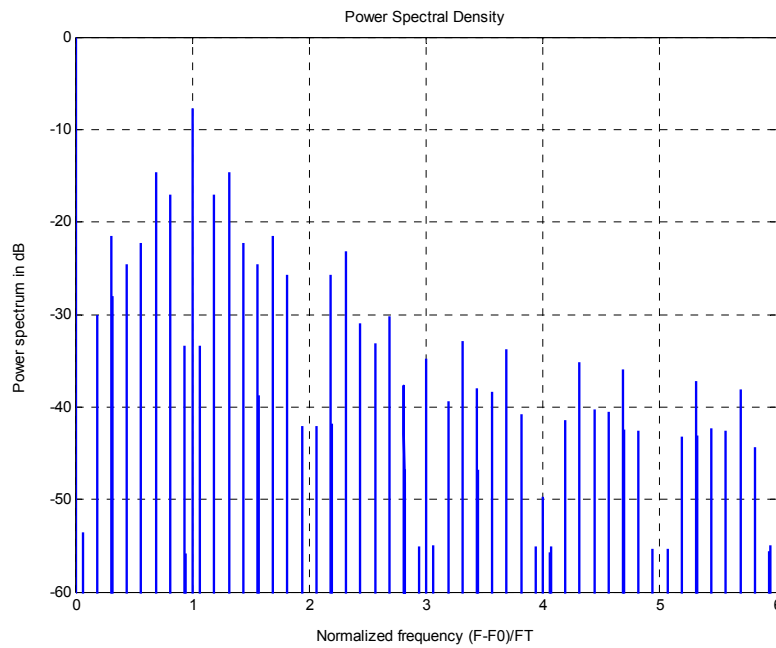

**Figure 4: Ranging signal spectrum for code length =  $2^4$**

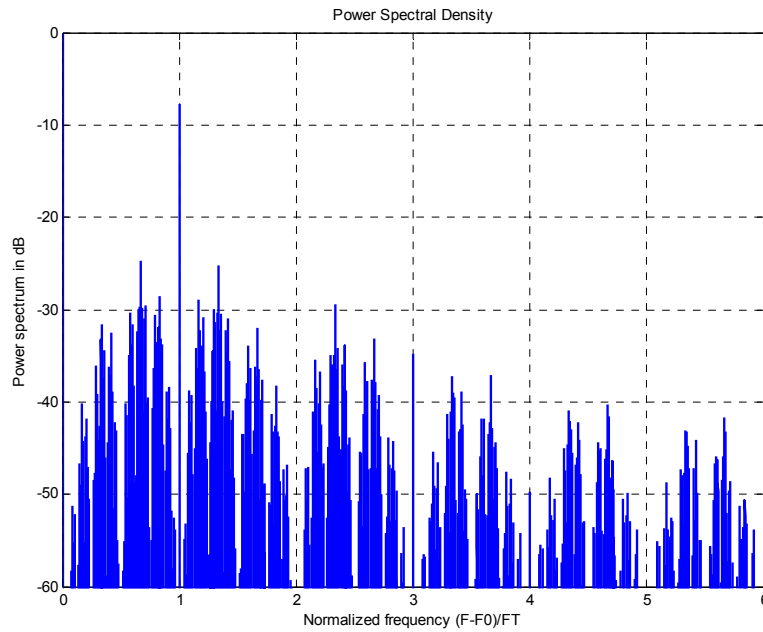

**Figure 5: Ranging signal spectrum for code length =  $2^{12}$**

#### 4.2.3.2 Ranging tone selection

##### 4.2.3.2.1 Nominal tone frequency

The nominal tone frequency  $f_t$  plus and minus its expected Doppler shift, shall be selected within the range 100 kHz – 1,5 MHz and in a region of the transponder bandwidth where the group delay is stable within the specified accuracy.

##### 4.2.3.2.2 Selection of the frequency

###### a. Interference between ranging and telemetry

1. In order to minimize interference between ranging and telemetry, the following conditions should be taken into account:

$$| D f_t - f_{sc} | \geq 2,5 f_{\text{symp}}$$

$$| D f_t - 3 f_{sc} | \geq f_{\text{symp}}$$

$$| k f_{\text{symp}} - D f_t | \geq 5 \text{ Hz}$$

where

$f_t$  = tone frequency

$f_{\text{symp}}$  = telemetry symbol rate

$f_{sc}$  = telemetry subcarrier frequency

$k$  = integer

$D$  = one-way Doppler factor =  $\sqrt{\frac{1 - v/c}{1 + v/c}}$

$v$  = spacecraft radial velocity

$c$  = speed of light

2. If SP-L modulation is used for the telemetry signal,  $f_{sc} = f_{\text{symp}}$  should be assumed.
3. If in the case described in provision 2. above, the conditions specified



in provision 1. above yield a tone frequency not compatible with the mission requirements,  $f_t$  shall be selected close to a null of the SP-L spectrum but separated from the null by more than the Doppler shift plus 5 Hz.

4. Frequency instability of the telemetry signal shall be taken into account in the equations in provision 1. above.

**NOTE:** The interference level is strongly dependent on the ranging signal-to-noise density ratio ( $S/N_0$ ) in the spacecraft's transponder. These provisions are applicable for high  $S/N_0$  ratios. When the conditions specified in provisions 1 to 4 above cannot be satisfied, the tone frequency is selected by means of an optimization tailored to the requirements of the mission concerned.

b. Interference between ranging and telecommand

1. If the simultaneous ranging and telecommand mode is selected (see also subclause 4.2.2.5), the following conditions should be taken into account in order to minimize this interference:

(a) PCM(NRZ-L)/PSK/PM telecommand

$$| 2 m f_{TC} - f_t | \geq 5 \text{ Hz}$$

$$| (2 n - 1) f_{TC} - f_t | \geq 2 f_b$$

where

$f_t$  = tone frequency  
 $f_b$  = telecommand bit rate  
 $f_{TC}$  = telecommand subcarrier frequency  
 $m, n$  = integers

(b) PCM(SP-L)/PM telecommand

$$| f_t - f_b | \geq 2,5 f_b$$

$$| f_t - 3 f_b | \geq f_b$$

$$| k f_b - f_t | \geq 5 \text{ Hz}$$

where

$f_t$  = tone frequency  
 $f_b$  = telecommand bit rate  
 $k$  = integer

2. If the conditions for the PCM(SP-L)/PM telecommand (see b.1.(b)) yield a tone frequency not compatible with the mission requirements,  $f_t$  shall be selected close to a null of the SP-L telecommand spectrum, but separated from the null by more than 5 Hz.

**NOTE:** In the case of the PCM(SP-L)/PM telecommand specified in b.1.(b) above, telecommand and telemetry modulation schemes are selected taking into account their mutual interference, in the case of simultaneous telecommand, ranging and telemetry.

### 4.3. Carrier frequency stability

Requirements on carrier frequency stability in 4.4 and 4.5 refer to Figure 6. This subclause explains how to interpret and apply this figure.

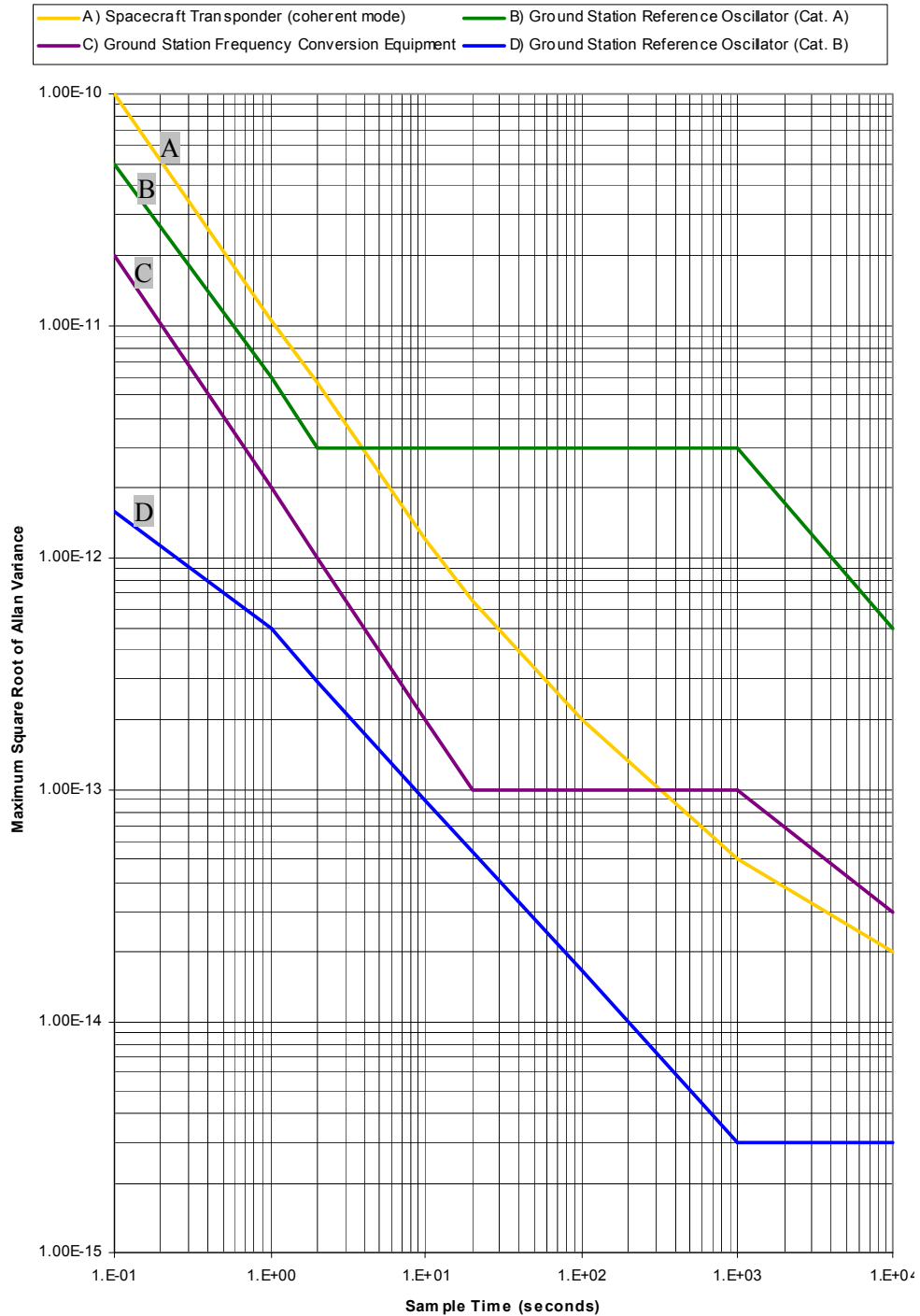

**Figure 6: Carrier frequency stability requirements**

The Allan variance is defined as:

$$\sigma^2(\tau) = \lim_{m \rightarrow \infty} \frac{1}{2(m-1)} \cdot \sum_{j=2}^m (\bar{y}_j - \bar{y}_{j-1})^2$$

where

$$\bar{y}_j = \frac{\phi((j+1)\tau) - \phi(j\tau)}{2\pi f_0 \tau}$$

$m$  = number of average fractional frequency samples;

$\tau$  = sample time;

$\phi$  = instantaneous phase measurement samples.

For both curves A and C in Figure 6, the sample time  $\tau$  is the duration over which the integrated Doppler measurement is processed.

For both curves B and D in Figure 6, the sample time  $\tau$  for computing the integrated Doppler bias is the signal round-trip light time.

For computing the Integrated Doppler jitter from curves B and D in Figure 6,  $\tau$  is the duration over which the integrated Doppler measurement is processed.

## 4.4. Earth station

### 4.4.1 Earth-to-Space link

The following requirements shall be met by the Earth-to-Space link:

- |    |   |  |
|----|---|--|
| a. | Tone frequency selectable range ( $f_t$ )         | 100 kHz – 1,5 MHz                      |
| b. | Code period                                       | $2^n / f_t$ with $n = 0, 1, \dots, 20$ |
| c. | Modulation scheme                                 | PCM/PSK/PM                             |
| d. | Tone modulation index <sup>9</sup>                | 45° or 22,5°                           |
| e. | Carrier modulation index                          |  |
|    | 1. Minimum, ranging only                          | 0,1 rad peak                           |
|    | 2. Maximum, ranging only                          | 1,4 rad peak                           |
|    | 3. Ranging and telecommand                        | $\leq 1,75$ rad peak                   |
| f. | Spurious signals                                  | < -60 dBc                              |
| g. | Phase noise density                               |  |
|    | 1. Category A                                     |  |
|    | (a) for $10 \text{ Hz} \leq f \leq 1 \text{ MHz}$ | $-(48 + 10 \log(f)) \text{ dBc/Hz}$    |
|    | (b) for $f > 1 \text{ MHz}$                       | $< -108 \text{ dBc/Hz}$                |
|    | 2. Category B                                     |  |
|    | (a) for $1 \text{ Hz} \leq f \leq 1 \text{ MHz}$  | $-(51 + 10 \log(f)) \text{ dBc/Hz}$    |

<sup>9</sup> As a baseline, 45° is used during ambiguity resolution and 22,5° during the measurement phase for the PCM/PSK modulation of the tone by the code.

	(b) for $f > 1$ MHz	$< -111$ dBc/Hz
h.	Earth-to-Space link carrier frequency stability	
	1. reference frequency	Figure 6, curves B and D
	2. frequency converters	Figure 6, curve C
i.	Group delay variation vs. time	
	1. Category A	20 ns/12 h pp
	2. Category B	2 ns/12 h pp
j.	Group delay variation over 3 MHz bandwidth	
	1. Category A	5 ns pp
	2. Category B	2,5 ns pp
k.	Timing accuracy	
	1. Category A	$\leq 10$ $\mu$ s relative to UTC
	2. Category B	$\leq 1$ $\mu$ s relative to UTC

## 4.4.2 Space-to-Earth link

### 4.4.2.1 Residual carrier modulation

The following requirements shall be met by the Space-to-Earth link:

a.	Minimum C/N ratio in carrier PLL $2B_L$	15 dB
b.	Ranging effective modulation index	0,01 to 0,7 rad peak
c.	Ranging acquisition and tracking	
	1. Tone PLL loop order	second
	2. Minimum ranging SNR in tone PLL $2B_L$	19 dB
	3. Technological degradation <sup>10</sup>	$\leq 3$ dB
	4. Tone PLL loop bandwidth $2B_L$ , selectable	$10^{-3}$ Hz to 3 Hz
	5. Damping factor	$1 \pm 0,1$
	6. Maximum Doppler rate <sup>11</sup>	
	(a) Tracking limit	10 Hz/s (category A) 1 Hz/s (category B)
	(b) For specified accuracy	2 Hz/s (category A) 0.02 Hz/s (category B)
	7. Tone integration time for acquisition	1-1000 s (categories A and B)
	8. Code integration time	0,5-1000 s (categories A and B)
	9. Number of codes to be resolved	$n$ (categories A and B)

<sup>10</sup> Such degradation applies when computing noise-induced jitter, but not for verifying if the ranging signal is above the equipment threshold.

<sup>11</sup> The figures given here apply to the ranging system performance only.

10.	Acquisition time <sup>12</sup> for $n = 10$	< 12 s (category A) < 1500 s (category B)
11.	Doppler sampling rate	$\leq 10/s$ (categories A and B)
12.	Ranging sampling rate	$\leq 1/s$ (categories A and B)
d.	Doppler tracking	
1.	Carrier PLL loop order	
(a)	Category A	second
(b)	Category B	second or third
2.	Technological degradation <sup>13</sup>	$\leq 3$ dB
3.	Doppler sampling rate	$\leq 10/s$
e.	Phase noise density:	
1.	Category A	
(a)	For $10 \text{ Hz} \leq f \leq 1 \text{ MHz}$	$-(48 + 10 \log(f)) \text{ dBc/Hz}$
(b)	For $f > 1 \text{ MHz}$	$< -108 \text{ dBc/Hz}$
2.	Category B	
(a)	For $1 \text{ Hz} \leq f \leq 1 \text{ MHz}$	$-(51 + 10 \log(f)) \text{ dBc/Hz}$
(b)	For $f > 1 \text{ MHz}$	$< -111 \text{ dBc/Hz}$
f.	Space-to-Earth link carrier frequency stability	
1.	reference frequency	Figure 6, curves B and D
2.	frequency converters	Figure 6, curve C
g.	Group delay variation vs. time	
1.	Category A	20 ns/12 h pp
2.	Category B	2 ns/12 h pp
h.	Group delay variation over 3 MHz bandwidth <sup>14</sup>	
1.	Category A	5 ns pp
2.	Category B	2,5 ns pp
i.	Timing accuracy	
1.	Category A	$\leq 10 \mu\text{s}$ relative to UTC
2.	Category B	$\leq 1 \mu\text{s}$ relative to UTC

<sup>12</sup> For a probability of incorrect ambiguity resolution of  $10^{-2}$ .

<sup>13</sup> Such degradation applies when computing noise-induced jitter, but not for verifying if the carrier level is above the equipment threshold.

<sup>14</sup> In case of polarization diversity combination, these conditions can be achieved only with a proper compensation of the differential delay.

#### 4.4.2.2 Suppressed carrier modulation <sup>15</sup>

The following requirements shall be met by the Space-to-Earth link:

- |    |  |                                       |
|----|--|---------------------------------------|
| a. | Minimum C/N <sup>16</sup> ratio in carrier loop $2B_L$ | 15 dB                                 |
| b. | Doppler tracking                                       |                                       |
|    | 1. Carrier PLL loop order                              | second                                |
|    | 2. Technological degradation <sup>17</sup>             | $\leq 3$ dB                           |
|    | 3. Doppler sampling rate                               | $\leq 10/s$                           |
| c. | Phase noise density:                                   |                                       |
|    | 1. Category A  |                                       |
|    | (a) for $10 \text{ Hz} \leq f \leq 1 \text{ MHz}$      | $-(48 + 10 \log(f)) \text{ dBc/Hz}$   |
|    | (b) for $f > 1 \text{ MHz}$                            | $< -108 \text{ dBc/Hz}$               |
|    | 2. Category B  |                                       |
|    | (a) for $1 \text{ Hz} \leq f \leq 1 \text{ MHz}$       | $-(51 + 10 \log(f)) \text{ dBc/Hz}$   |
|    | (b) for $f > 1 \text{ MHz}$                            | $< -111 \text{ dBc/Hz}$               |
| d. | Space-to-Earth link carrier frequency stability        |                                       |
|    | 1. reference frequency                                 | Figure 6, curves B and D              |
|    | 2. frequency converters                                | Figure 6, curve C                     |
| e. | Timing accuracy  |                                       |
|    | 1. Category A  | $\leq 10 \mu\text{s}$ relative to UTC |
|    | 2. Category B  | $\leq 1 \mu\text{s}$ relative to UTC  |

## 4.5. Spacecraft transponder

### 4.5.1 General

The requirements in 4.5.2 to 4.5.10 apply to spacecraft transponders employed for category A and category B missions. For the purposes of this Standard, spacecraft transponder means the ensemble of transponder, high power amplifier if external to the transponder, diplexer and radio frequency distribution unit.

### 4.5.2 Range and range rate operations

- a. For deep space operations and for those missions using two-way Doppler measurements, the transponder shall be of the coherent type, i.e. the Space-to-Earth link carrier shall be derived coherently from the Earth-to-Space link carrier through multiplication by the turn-around ratio over the transponder tracking range.

**NOTE:** Turn-around ratios are specified in Table 2 of ECSS-E-50-05A.

<sup>15</sup> Only Doppler tracking can be used in this mode.

<sup>16</sup> Equivalent C/N ratio taking into account squaring loss.

<sup>17</sup> Such degradation applies when computing noise-induced jitter, but not for verifying if the carrier level is above the equipment threshold.

- b. In case of on-board digital synthesis, the deviation from the ideal turn-around ratio shall be such that the resulting Doppler error (bias) does not exceed 0,1 mm/s averaged over 1 s.
- c. The ranging signal shall be demodulated in the transponder, from the Earth-to-Space link carrier, and then be re-modulated onto the Space-to-Earth link carrier.
- d. The following two independent mode selections shall be accessible by telecommand:
  - 1. transponder coherent/non-coherent, and
  - 2. ranging modulation on/off.
- e. Coherent transponders used for Doppler tracking shall meet the carrier frequency stability requirements of curve A in Figure 6.

**NOTE:** The values are applicable to the complete assembly of the equipment concerned, from uplink reception to downlink transmission in static conditions corresponding to the nominal input power level range, and in all operational modes (including when the uplink is not modulated and the ranging channel in the transponder is enabled).
- f. For the combined influence of temperature and supply voltage over the operational range, input power over any 10 dB within the transponder dynamic range and uplink frequency shifts of  $\pm 3 \times 10^{-5}$ , the peak-to-peak phase shift of the transmitted carrier shall not exceed  $\pi/4$ .

### 4.5.3 Range only operations

- a. For missions that use ranging measurements only, the transponder need not be of the coherent type.
- b. The ranging signal shall be demodulated in the transponder, from the Earth-to-Space link carrier, and then be re-modulated onto the Space-to-Earth link carrier.
- c. One mode selection shall be accessible by telecommand: ranging modulation on/off.

### 4.5.4 Group delay

#### 4.5.4.1

- a. For the purposes of ambiguity resolution for both category A and category B missions, the group delay of the ranging channel shall be constant to within  $\pm 1/(5 f_i)$  within the range  $0,3 f_i$  to  $1,7 f_i$  as seen from the diplexer interface.
- b. The requirement in a. above shall be applied for any values within the nominal range of carrier frequency (taking into account Doppler shift), input level, modulation index, power supply, temperature and lifetime.

#### 4.5.4.2

- a. For the purposes of ranging measurement for both category A and category B missions, the group delay of the ranging channel at the tone frequency  $f_t$  shall be constant to within  $\pm 30$  ns as seen from the diplexer interface.

- b. The requirement in a. above shall be applied over the nominal range of carrier and tone frequencies (taking into account Doppler shift), input level, modulation index, power supply, temperature and lifetime.

#### 4.5.4.3

- a. If specified by mission analysis, the capability of knowing the total on-board delay at any time to a mission specific accuracy, by means of predicted Doppler and telemetered data of input level, power supply voltage, and temperature, shall be implemented.

NOTE: Usual values of calibration accuracy are  $\pm 5$  ns for category A and  $\pm 2,5$  ns for category B missions.

- b. When compliance with provision a. above involves calibration data of group delay versus carrier and tone frequency (taking into account Doppler shift), input level, modulation index, temperature, and power supply voltage, this calibration shall be produced by the manufacturer, unless it can be demonstrated that the data are insensitive to such parameters.

#### 4.5.5 Telemetered monitoring

In order to verify correct functioning of the system and for calibration purposes, telemetry information shall be available regarding:

- a. the chosen mode of operation,
- b. the receiver input level,
- c. the receiver frequency offset from the best lock frequency,
- d. the lock status, and
- e. the transponder temperature and power supply voltage.

#### 4.5.6 Amplitude response

- a. The amplitude response of the ranging channel (RF-in to RF-out) for both category A and category B missions shall be  $\pm 0,5$  dB from  $0,3 f_i$  to  $1,7 f_i$ .
- b. The attenuation of the ranging channel at  $0,1 f_i$  and  $1,9 f_i$  shall be less than 3 dB.
- c. Except for the case specified in d below, the one-sided noise bandwidth shall be less than or equal to  $2,5 f_i$ .
- d. In the case of standard off-the-self transponders designed for multiple versions, the ranging tone selection shall be carried out taking into account available transponder noise bandwidths to minimize the loss in the effective Space-to-Earth link ranging modulation index.

#### 4.5.7 Phase modulation

A positive phase shift on the Earth-to-Space link shall give rise to a positive shift on the Space-to-Earth link.



#### **4.5.8 Baseband automatic gain control (AGC)**

- a. An AGC system shall be employed in the video ranging channel, working to keep the root mean square (r.m.s.) of signal plus noise at the transponder modulator input constant.
- b. The AGC response time shall be more than 10 ms, and less than 30 ms.

#### **4.5.9 Modulation index**

- a. The nominal Space-to-Earth link modulation index for the ranging channel shall be in the range 0,1 rad to 0,7 rad.
- b. For category B missions, the modulation index shall be selectable by telecommand to at least two values between 0,2 rad and 0,7 rad.
- c. Link design shall ensure that the effective Space-to-Earth link ranging modulation index always conforms to 4.4.2.1.b.

#### **4.5.10 Ranging technological loss**

- a. The transponder end-to-end technological loss (see Annex B) for both category A and category B missions shall be less than or equal to 1 dB.

**NOTE:** This includes all internal transponder contributions in the demodulation and modulation process taking into account also phase noise and quantization effects (in case of digital implementation of the ranging function).

- b. Provisions in a. above shall be applied in all operational modes, over the nominal range of carrier and tone frequencies (taking into account Doppler shift), input level, modulation index, power supply, temperature and lifetime.

### **4.6. Performance**

#### **4.6.1 Purpose**

The purpose of this subclause (4.6) is to specify the requirements that determine the end-to-end performance of the ranging and Doppler tracking system, but not the final performance of the orbit determination process, which is beyond the scope of the present standard.

#### **4.6.2 Integrated Doppler performance**

##### **4.6.2.1 Overview**

The accuracy of the integrated Doppler measurement is affected by several error sources for which the minimum requirements concerning system accuracy are as specified in subclauses 4.6.2.2 and 4.6.2.3. The standard deviation of the uncorrelated noise induced errors can be reduced by pre-processing (averaging) individual measurements.

#### 4.6.2.2 Systematic errors (bias)

- a. The error due to the station reference stability (drift) shall be as per subclauses 4.4.1.h.1, 4.4.2.1.f.1 and 4.4.2.2.d.1

NOTE: This normally results in a negligible contribution for missions up to lunar distance, and 0,5 mm/s for missions at Lagrangian points.

- b. For a digital implementation of the station transmit carrier generation, any offset from the nominal uplink carrier frequency shall be considered in the Doppler data processing.
- c. The error due to on-board digital synthesis for coherent transponders shall be as per subclause 4.5.2.b.
- d. The error due to the acceleration and acceleration rate at the station and at the spacecraft shall be computed assuming the carrier PLL order loops (subclauses 4.4.2.1.d.1 and 4.4.2.2.b.1 for stations) and loop bandwidths used.

#### 4.6.2.3 Noise induced errors (jitter)

- a. The error due to the station reference stability (jitter) shall be as per subclauses 4.4.1.h.1, 4.4.2.1.f.1 and 4.4.2.2.d.1.
- b. The error due to the station frequency converters stability shall be as per subclauses 4.4.1.h.2, 4.4.2.1.f.2 and 4.4.2.2.d.2.
- c. The error due to carrier frequency stability for coherent transponders shall be as per clause 4.5.2.e.
- d. The quantization error of the measurement shall be less than 1/1000 of the carrier period.
- e. The error due to the thermal noise at the station and at the spacecraft shall be computed assuming the PLL loop type and bandwidths used, and the technological degradation of clauses 4.4.2.1.d.2 and 4.4.2.2.b.2.
- f. The error due to the phase noise at the station shall be as per subclauses 4.4.1.g, 4.4.2.1.e and 4.4.2.2.c.

NOTE 1 This normally results in a negligible contribution.

NOTE 2 The contribution due to the phase noise of the transponder is covered by c. above.

### 4.6.3 Ranging performance

#### 4.6.3.1 Overview

The accuracy of the ranging measurement is affected by several error sources for which the minimum requirements concerning system accuracy are as specified in subclauses 4.6.3.2 and 4.6.3.3. The standard deviation of uncorrelated noise induced errors can be reduced by pre-processing (averaging) individual measurements.

#### 4.6.3.2 Systematic errors (bias)

- a. The error due to the station group delay variation versus time shall be as per subclauses 4.4.1.i and 4.4.2.1.g.
- b. If the error specified in a. above exceeds the mission requirement, station calibration shall be performed before and after the ranging measurement.

- c. The error due to the station group delay variation versus frequency should be as per subclauses 4.4.1.j and 4.4.2.1.h.

NOTE: Since normal mission scenarios result in small Doppler shifts on the nominal carrier and tone frequencies, this effect is typically negligible.

- d. In the case that c. above cannot be achieved, station calibration at different frequencies over the mission specific frequency variation should be performed.
- e. The error due to the transponder group delay stability and variation shall be as per subclauses 4.5.4.4.5.4.2, 4.5.4.3 and b.
- f. The error due to the acceleration and acceleration rate at the station and at the spacecraft shall be computed assuming the PLL order loops (subclause 4.4.2.1.c.1 for stations) and loop bandwidths used.
- g. The error due to the station reference stability shall be as per subclauses 4.4.1.h.1, 4.4.2.1.f.1 and 4.4.2.2.d.1.

NOTE: This normally results in a negligible contribution.

#### **4.6.3.3 Noise induced errors (jitter)**

- a. The quantization error of the measurement shall be less than or equal to  $1/65536$  of the tone period.
- b. The measurement accuracy of the station ranging system shall be 1 ns or  $1/1000$  of the tone period, whichever is larger.
- c. The error due to the thermal noise at the station shall be computed assuming the tone PLL loop bandwidth used, the selected tone frequency, and the technological degradation of subclause 4.4.2.1.c.3 plus the transponder contribution to the link budget as per subclauses 4.5.6.c and 4.5.10.
- d. The error due to the phase noise at the station shall be as per subclauses 4.4.1.g, and 4.4.2.1.e.

NOTE: This normally results in negligible contribution.

#### **4.6.4 Ancillary measurements**

##### **4.6.4.1 Introduction**

The accuracy of the orbit determination process is also influenced by the error due to the propagation of electromagnetic waves through the atmosphere (both tropospheric and ionospheric propagation errors, multipath effects and scintillations), through plasma in the interplanetary paths, and the error in the station position measurement. Requirements in subclause 4.6.4.2 for Earth stations ensure the minimization of such effects.

#### 4.6.4.2 Ancillary measurements performance <sup>18</sup>

- a. For correction of the tropospheric error, the following measurements shall be carried out at the station with the herein specified accuracy:
  1. atmospheric pressure  $\pm 1$  hPa
  2. temperature  $\pm 1$  °C
  3. relative humidity  $\pm 1$  %
- b. For modelling of ionospheric density variation and the effect of the inter-planetary plasma, two measurement methods may be used:
  1. Multiple-frequency Doppler or ranging.  
**NOTE:** This uses a multiple carrier frequency transmission. There is no guarantee of the availability of this feature if the ground network responsible is not contacted at an early stage.
  2. Differenced range versus integrated Doppler (DRVID).  
**NOTE:** There is no guarantee of the availability of this feature if the ground network responsible is not contacted at an early stage.
- c. The station location (antenna phase centre) shall be determined to an accuracy better of than 0,5 m.

---

<sup>18</sup> The local meteo model can be sufficient to meet the project specific accuracy requirements. If this is the case, this subclause 4.6.4.2 can be tailored-out.

# 5

## Compatibility testing

---

### 5.1. General

The tests to demonstrate compatibility of ranging transponder and Earth equipment as specified in subclause 5.2:

- a. may be combined with similar telecommand and telemetry compatibility tests;
- b. shall be made with spacecraft and Earth station equipment which is electrically representative of the operational units;
- c. shall use as spacecraft equipment engineering qualification models as a minimum.

**NOTE:** Such equipment is usually integrated into a portable "compatibility test unit" (sometimes referred to as a "suitcase").

### 5.2. Tests

The following tests shall be run in order to demonstrate compatibility:

- a. frequency measurement of the Space-to-Earth link non-coherent carrier as a function of time after switch-on;
- b. spectrum examination of the Space-to-Earth link:
  1. check for spurious signals, and
  2. measurements of modulation indices;
- c. output power of the transponder transmitter;
- d. phase jitter of the Space-to-Earth link carrier;
- e. ranging signal group delay and jitter as a function of:
  1. ranging tone frequency,
  2. Earth-to-Space and Space-to-Earth link power and Doppler shift,
  3. modulation index,

4. presence of telecommand and telemetry (if this mode is operationally foreseen), and
5. comparison with the values established during spacecraft system testing (correcting for different power supply and temperature values);
- f. demonstration of correct ambiguity resolution, as a function of input signal level and ranging code;
- g. coherent transponder phase stability (Allan variance) as a function of:
  1. Earth-to-Space and Space-to-Earth link power and Doppler shift,
  2. presence of telecommand and telemetry (if this mode is operationally expected);
- h. coherent transponder turn-around ratio as a function of input frequency.

## Annex A (Informative)

# Compatibility with other ground stations networks

---

### A.1 General

The perceived degree of compatibility between transponders designed against this standard for ranging and Doppler tracking and other networks is illustrated in this Annex.

**NOTE:** There is no guarantee of the availability of such external networks for ranging and Doppler tracking if the ground network responsible is not contacted at an early stage.

### A.2 Category A missions

The Consultative Committee for Space Data Systems (see CCSDS 401.0-B) recommendation for Category A missions assumes that a tone ranging system is used with a major tone at 100 kHz and minor tones as low as 4 kHz. For this reason the CCSDS recommends the following three clauses:

- a. that spacecraft transponders incorporate a bandpass filter in their ranging channel;
- b. that the transponder ranging channel's baseband frequency response be uniform within  $\pm 0.5$  dB within the frequency range 3 kHz to 110 kHz;
- c. that the transponder's ranging channel be designed to not deviate by more than  $\pm 6$  degrees from a linear phase-frequency relationship within the frequency range 3 kHz to 110 kHz.

Transponders compliant with this standard do not automatically meet the above requirements A.2.b and A.2.c (see clauses 4.5.4.a, 4.5.6.a and 4.5.6.b) in the low frequency range, even when a 100 kHz major tone is used. Given the fact that a minor tone as low as 3 kHz need not always be used for resolving the ambiguity of the mission concerned and that some networks employ a subcarrier at 16 kHz for the minor tones, it is reasonable to assume that no major incompatibility is likely to occur, although the measurement performance can be less good than for a network designed against this standard.

### A.3 Category B missions

The Consultative Committee for Space Data Systems (see CCSDS 401.0-B) recommendation for Category B missions assumes that a ranging system is used with a 1 MHz square wave or sine wave tone and with ranging components (resulting from the modulation of the tone with the code) as low as 1 Hz. For this reason, the CCSDS recommends the following five clauses:

- a. that spacecraft transponders incorporate a bandpass filter in their ranging channel;
- b. that the transponder ranging channel's baseband frequency response be uniform within  $\pm 0.5$  dB within the frequency range 3 kHz to 1.1 MHz;
- c. that the one-half power (-3 dB) bandpass frequencies of the transponder's ranging channel be greater than 3 MHz and less than 1 kHz;
- d. that the transponder's ranging channel be designed to not deviate by more than  $\pm 6$  degrees from a linear phase-frequency relationship from 1 kHz to 3 MHz;
- e. that the one-sided equivalent noise bandwidth be limited to 3.5 MHz.

Transponders compliant with this standard do not automatically meet the above requirements A.3.b, A.3.c and A.3.d (see clauses 4.5.4.a, 4.5.6.a and 4.5.6.b) in the low as well as in the high frequency range, even when a 1 MHz tone is used. Given the fact that a sine wave tone is becoming the choice for spectral occupancy reasons and that frequency chopping (modulo-2 addition of the selected ranging component with the fundamental square wave or other higher frequency components) is available on at least one non-European network, it is reasonable to assume that no major incompatibility is likely to occur, although the measurement performance can be less good than for a network designed against this standard.



## Annex B (Informative)

# Transponder ranging technological loss

---

The technological loss  $L_{TECH}$  is defined as the degradation in the ranging tone power over noise spectral density  $(P_R / N_0)$  as measured at the transmitter output with respect to its theoretical value  $(P_R / N_0)_{TH}$ .

For instance, in the case of ranging only modulation, the theoretical value can be computed as:

$$(P_R / N_0)_{TH} = (C / N_0) + 20 \cdot \log_{10} [J_1(m_R)] + 3 \text{ (in dB)}$$

where

$P_R$  = ranging tone signal power;

$N_0$  = single-sided noise spectral density;

$C$  = unmodulated Earth-to-Space link carrier power;

$J_1$  = modified Bessel function of first order;

$m_R$  = Earth-to-Space link ranging modulation index (in rad peak),

and the technological loss is represented as:

$$L_{TECH} = (P_R / N_0)_{TH} - (P_R / N_0)$$

Such losses can only be measured by transmitting an unmodulated ranging tone.

*(This page is intentionally left blank)*

---

## Annex C (informative)

# Integrated Doppler measurement

---

The following simplified explanation is an approximation to illustrate the principles of integrated Doppler measurement.

The radial velocity of the spacecraft is determined by measuring the two-way shift of the Earth-to-Space link carrier frequency, with the aid of a coherent transponder. A simplified diagram showing the various frequencies involved is presented in Figure C- 1.

Integrated Doppler measurements (one-way Doppler) can also be made with the transponder in non-coherent mode. In this case, the Doppler measurement is relative to the Space-to-Earth carrier.

Integrating the Doppler-shifted carrier yields a change in phase angle, which represents a change in distance (delta-range) between the spacecraft and the Earth station.

Consecutive Doppler frequency measurements are not carried out as independent velocity measurements, but the continuous phase development versus time is measured. This method turns the measurement into a high-resolution determination of the range, to within an unknown integration constant: since the phase,  $\phi$ , of the Space-to-Earth link frequency is measured from an initial phase  $\phi_0$  at time  $t_0$  onwards, the phase difference ( $\phi - \phi_0$ ) corresponds to the change in the propagation path.

This method is referred to as "integrated Doppler measurement", or "non-destructive range-rate measurement".

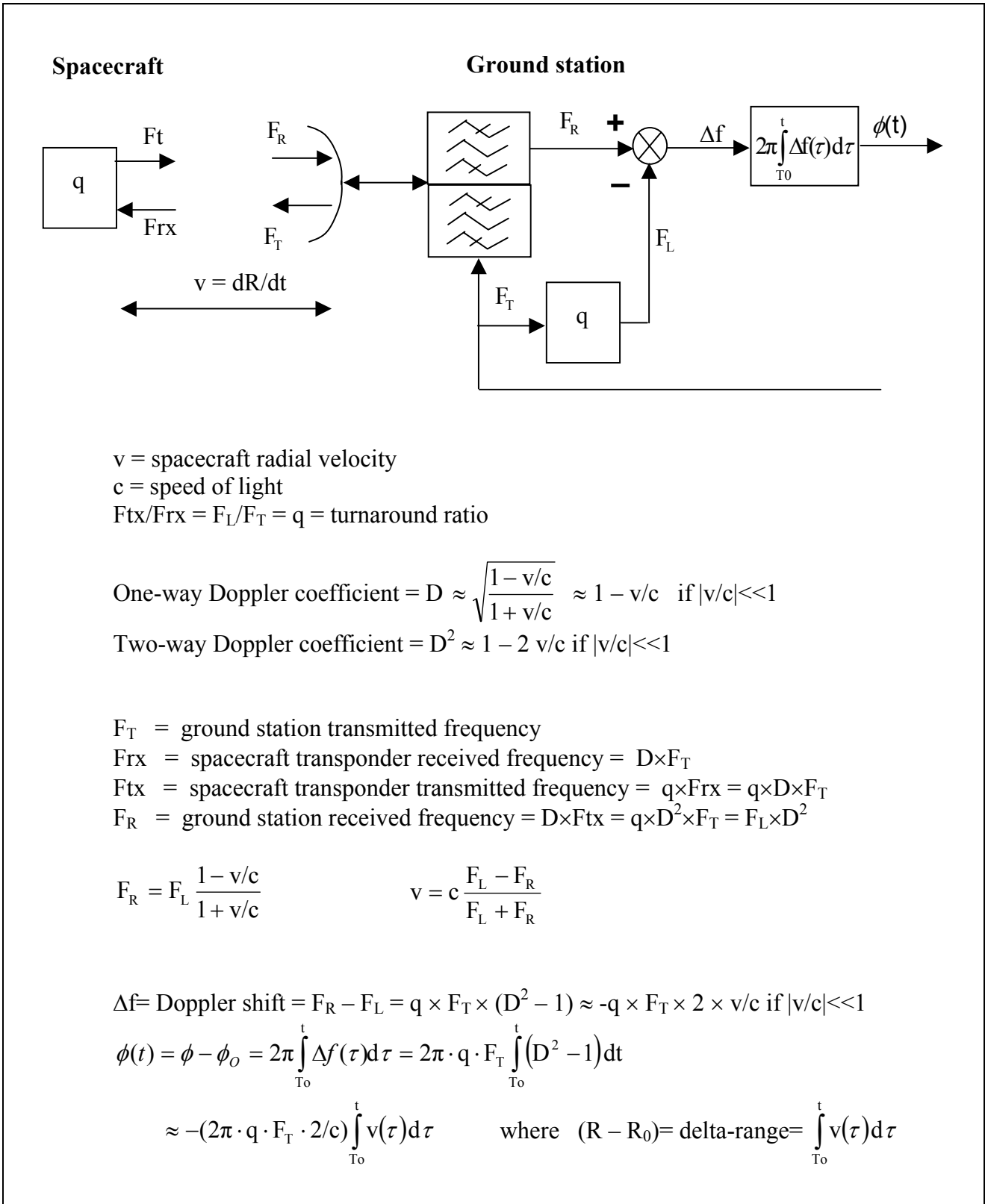

**Figure C- 1: Integrated Doppler measurement**

## Bibliography

---

CCSDS 401.0-B

Radio Frequency and Modulation Systems –  
Part 1: Earth Stations and Spacecraft

*(This page is intentionally left blank)*

## ECSS Change Request / Document Improvement Proposal

A Change Request / Document Improvement Proposal for an ECSS Standard may be submitted to the ECSS Secretariat at any time after the standard's publication using the form presented below.

This form can be downloaded in MS Word format from the ECSS Website  
([www.ecss.nl](http://www.ecss.nl), in the menus: Standards - ECSS forms).



## ECSS Change Request / Document Improvement Proposal

1. Originator's name: Organization: e-mail:		2. ECSS Document number: 3. Date:		
4. Number.	5. Location of deficiency clause page (e.g. 3.1 14)	6. Changes	7. Justification	8. Disposition

### Filling instructions:

1. **Originator's name** - Insert the originator's name and address
2. **ECSS document number** - Insert the complete ECSS reference number (e.g. ECSS-M-00B)
3. **Date** - Insert current date
4. **Number** - Insert originator's numbering of CR/DIP (*optional*)
5. **Location** - Insert clause, table or figure number and page number where deficiency has been identified
6. **Changes** - Identify any improvement proposed, giving as much detail as possible
7. **Justification** - Describe the purpose, reasons and benefits of the proposed change
8. **Disposition** - not to be filled in (*entered by relevant ECSS Panel*)

Once completed, please send the CR/DIP by e-mail to: [ecss-secretariat@esa.int](mailto:ecss-secretariat@esa.int)

(This page is intentionally left blank)