



# **Space engineering**

---

## **Photovoltaic assemblies and components**

**ECSS Secretariat  
ESA-ESTEC  
Requirements & Standards Division  
Noordwijk, The Netherlands**

## Foreword

This Standard is one of the series of ECSS Standards intended to be applied together for the management, engineering and product assurance in space projects and applications. ECSS is a cooperative effort of the European Space Agency, national space agencies and European industry associations for the purpose of developing and maintaining common standards. Requirements in this Standard are defined in terms of what shall be accomplished, rather than in terms of how to organize and perform the necessary work. This allows existing organizational structures and methods to be applied where they are effective, and for the structures and methods to evolve as necessary without rewriting the standards.

This Standard has been prepared by the ECSS-E-ST-20-08C Working Group, reviewed by the ECSS Executive Secretariat and approved by the ECSS Technical Authority.

## Disclaimer

ECSS does not provide any warranty whatsoever, whether expressed, implied, or statutory, including, but not limited to, any warranty of merchantability or fitness for a particular purpose or any warranty that the contents of the item are error-free. In no respect shall ECSS incur any liability for any damages, including, but not limited to, direct, indirect, special, or consequential damages arising out of, resulting from, or in any way connected to the use of this Standard, whether or not based upon warranty, business agreement, tort, or otherwise; whether or not injury was sustained by persons or property or otherwise; and whether or not loss was sustained from, or arose out of, the results of, the item, or any services that may be provided by ECSS.

Published by: ESA Requirements and Standards Division  
ESTEC, P.O. Box 299,  
2200 AG Noordwijk  
The Netherlands  
Copyright: 2008 © by the European Space Agency for the members of ECSS

## Change log

ECSS-E-20-08A 30 November 2004	First issue
ECSS-E-20-08B	Never issued
ECSS-E-ST-20-08C 31 July 2008	<p>Second issue</p> <p>The following is a summary of the changes in respect to ECSS-E-20-08A:</p> <ul style="list-style-type: none"><li>• The qualification, procurement, storage and delivery of external and integral protection diodes has been included in clause 9. The reason is that triple junction solar cells require protection diodes connected in parallel to each cell of the solar array string, to avoid the operation in reverse voltage (which can electrically damage the cell) of these devices, in certain operation conditions. It is important that protection diodes are integrated in the electrical network in such a way that there is no disturbance to present electrical network design. Therefore conventional EEE parts (i.e. encapsulated diodes) are not used, instead, special design, either being part of the cell (integral diodes) or silicon flat planar diodes are used. Main qualification test included in clause 9 are electron irradiation and electrical switching, extended storage simulation, contact adherence and electrostatic discharge and operational life test. Accordingly operational life test of solar cells are included at solar cell assembly level.</li><li>• Experience in the application of ECSS-E-20-08A to different satellite programmes, revealed several aspects that could be improved, modified or removed, without affecting the reliability of photovoltaic assemblies and components. A summary of those changes is presented below:<ul style="list-style-type: none"><li>• It has been reinforced in the scope, that the standard covers general qualification requirements but does not cover particular qualification requirements for specific missions.</li><li>• Provisions have been included to grant qualification of main PVA components when qualified at higher levels of assembly within the same satellite programme.</li><li>• General quality assurance requirements or references to these requirements have been removed because they are included in higher level ECSS-Q standards, which are generally applicable to any project using ECSS standards.</li><li>• It has been clarified that, in this standard the source control drawing has been selected on every level of assembly as a generic</li></ul></li></ul>

	<p>document to reflect the specific requirements.</p> <ul style="list-style-type: none"> <li>• PVA, solar cell assembly, bare solar cell and cover glass qualification matrix tables have been fully revised and accordingly modified.</li> <li>• Characterization tests of material properties have been removed from qualification test procedures, like four-point bending test of coverglasses and coupon samples.</li> <li>• The contents of the process identification document and the documentation data package have been harmonized and included as DRDs in annexes.</li> <li>• It have been clearly identified the limits of the PVA coupon design and qualification requirements with respect to the design and qualification requirements of the solar panels and solar arrays. Design measures that influence the sizing of the solar array like compensation for reliability losses have been deleted from this standard. Requirements that are applicable at solar panel or solar array level only have been deleted.</li> <li>• Some test procedures have been updated including best practices from companies on their qualified processes:             <ul style="list-style-type: none"> <li>• The level of traceability indicated by the solar cell marking shall be agreed with the supplier.</li> <li>• Electrical performance and contact thickness test procedures for acceptance testing of bare solar cells included.</li> <li>• UV exposure test conditions have been updated according to recent experiences during test campaigns.</li> <li>• Coating adherence test procedure on solar cells and diodes has to be agreed between customer and supplier.</li> <li>• Pull direction of the interconnector adherence test to be proposed by the supplier.</li> <li>• Solar cell visual inspection requirements which have to be defined by the supplier have been included in the body of the standard. New inspection techniques for solar cell visual inspection have been introduced</li> <li>• Requirements for the re-calibration of reference solar cells have been implemented.</li> </ul> </li> <li>• The following parts of the standard have been re-structured or completed:             <ul style="list-style-type: none"> <li>• In clause 3, missing definitions in version A, and new definitions applicable to the new material, have been included.</li> <li>• General requirements that apply on photovoltaic assemblies and components have been grouped in a dedicated clause (clause 4).</li> <li>• Normative annexes from version A other than DRDs, have been included now as clauses in the main body of the standard (clauses 10 and 11).</li> </ul> </li> </ul>
--	--

---

## Table of contents

---

<b>Change log</b> .....	<b>3</b>
<b>Introduction</b> .....	<b>13</b>
<b>1 Scope</b> .....	<b>14</b>
<b>2 Normative references</b> .....	<b>15</b>
<b>3 Terms, definitions and abbreviated terms</b> .....	<b>16</b>
3.1 Terms from other standards .....	16
3.2 Terms specific to the present standard .....	16
3.3 Abbreviated terms .....	21
<b>4 General</b> .....	<b>24</b>
4.1 Overview .....	24
4.1.1 Objective and organization .....	24
4.1.2 Interfaces with other areas .....	25
4.2 Physical properties .....	26
4.3 Test and storage .....	27
4.3.1 Test environment.....	27
4.3.2 Test tolerances and accuracies .....	27
4.3.3 Margins.....	28
4.4 Critical materials.....	28
<b>5 Photovoltaic assemblies</b> .....	<b>29</b>
5.1 Overview .....	29
5.1.1 Description.....	29
5.1.2 Purpose and objective .....	29
5.2 Conditions and method of test.....	30
5.3 Photovoltaic assembly design .....	31
5.3.1 Overview.....	31
5.3.2 Parameters related to parts, materials and processes (PMP).....	31
5.3.3 Parameters related to design .....	32
5.4 PVA manufacturing .....	36

---

5.4.1	Process validation .....	36
5.4.2	Defect acceptability .....	36
5.4.3	In-process testing .....	36
5.4.4	Identification and traceability .....	37
5.4.5	Recording .....	38
5.5	PVA tests.....	38
5.5.1	Qualification tests .....	38
5.5.2	Acceptance tests for qualification coupons .....	43
5.5.3	Definition of tests and checks.....	44
5.6	Failure definition .....	55
5.6.1	Failure criteria.....	55
5.6.2	Failed qualification coupons .....	55
5.7	Data documentation .....	55
5.8	Delivery .....	55
5.9	Packaging, packing, handling and storage.....	56
<b>6</b>	<b>Solar cell assemblies .....</b>	<b>57</b>
6.1	General.....	57
6.1.1	Testing.....	57
6.1.2	Conditions and methods of test.....	57
6.1.3	Deliverable components .....	57
6.1.4	Identification and traceability .....	58
6.2	Production control (process identification document).....	58
6.3	Acceptance tests .....	58
6.3.1	General.....	58
6.3.2	Test methods and conditions.....	59
6.3.3	Electrical performance acceptance test (EPA) .....	59
6.4	Qualification tests .....	59
6.4.1	General.....	59
6.4.2	Qualification.....	62
6.4.3	Test methods, conditions and measurements.....	63
6.5	Failure definition .....	74
6.5.1	Failure criteria.....	74
6.5.2	Failed SCAs.....	75
6.6	Data documentation .....	75
6.7	Delivery .....	75
6.8	Packing, dispatching, handling and storage.....	75
6.8.1	Overview.....	75

---

---

6.8.2	ESD Sensitivity .....	75
<b>7</b>	<b>Bare solar cells .....</b>	<b>76</b>
7.1	Testing, deliverable components and marking .....	76
7.1.1	Testing .....	76
7.1.2	Deliverable components .....	77
7.1.3	Marking .....	77
7.2	Production control (process identification document) .....	77
7.3	Acceptance tests .....	78
7.3.1	General .....	78
7.3.2	Test methods and conditions .....	79
7.3.3	Documentation .....	79
7.4	Qualification tests .....	79
7.4.1	General .....	79
7.4.2	Qualification .....	82
7.5	Test methods, conditions and measurements .....	83
7.5.1	Visual inspection (VI) .....	83
7.5.2	Dimensions and weight (DW) .....	85
7.5.3	Electrical performance (EP) .....	85
7.5.4	Temperature coefficients (TC) .....	86
7.5.5	Spectral response (SR) .....	87
7.5.6	Optical properties (OP) .....	87
7.5.7	Humidity and temperature (HT) .....	88
7.5.8	Coating adherence (CA) .....	89
7.5.9	Contact uniformity (CU) .....	90
7.5.10	Contact thickness (CT) .....	90
7.5.11	Surface finish (SF) .....	90
7.5.12	Pull test (PT) .....	91
7.5.13	Electron irradiation (EI) .....	91
7.5.14	Proton irradiation (PI) .....	92
7.5.15	Photon irradiation and temperature annealing (PH) .....	93
7.5.16	Solar cell reverse bias test (RB) .....	93
7.5.17	Thermal cycling (CY) .....	94
7.5.18	Active-passive interface evaluation test (IF) .....	94
7.5.19	Flatness test (FT) .....	94
7.6	Failure definition .....	95
7.6.1	Failure criteria .....	95
7.6.2	Failed components .....	95

---

---

7.7	Data documentation .....	95
7.8	Delivery .....	95
7.9	Packing, dispatching, handling and storage .....	96
7.9.1	Overview.....	96
7.9.2	ESD Sensitivity .....	96
<b>8</b>	<b>Coverglasses .....</b>	<b>97</b>
8.1	Overview .....	97
8.1.1	Purpose .....	97
8.1.2	Description.....	97
8.2	Interfaces.....	97
8.3	Testing, deliverable components and marking .....	98
8.3.1	Testing.....	98
8.3.2	Deliverable components .....	98
8.3.3	Marking (coating orientation) .....	99
8.4	Production control (Process identification document) .....	99
8.5	Acceptance tests .....	99
8.5.1	Acceptance test samples.....	99
8.5.2	Acceptance test sequence .....	100
8.5.3	Test methods and conditions.....	100
8.5.4	Documentation .....	100
8.6	Qualification tests .....	101
8.6.1	General.....	101
8.6.2	Qualification.....	101
8.7	Test methods, conditions and measurements.....	103
8.7.1	Visual inspection (VI).....	103
8.7.2	Transmission into air (TA) .....	104
8.7.3	Electro-optical properties (EO) .....	105
8.7.4	Mechanical properties .....	105
8.7.5	Reflectance properties (OP).....	106
8.7.6	Normal emittance ( $e_N$ ) (NE).....	108
8.7.7	Surface resistivity .....	108
8.7.8	Flatness or bow (FT) .....	108
8.7.9	Transmission into adhesive (TH).....	109
8.7.10	Boiling water test (BW) .....	109
8.7.11	Humidity and temperature .....	109
8.7.12	UV exposure (UV) .....	110
8.7.13	Electron irradiation (EI).....	111



---

8.7.14	Proton irradiation (PI) .....	111
8.7.15	Breaking strength (BS) .....	111
8.7.16	Thermal cycling (CY) .....	112
8.7.17	Abrasion resistance (coated surface) (AE) .....	112
8.7.18	Coating adhesion (TD) .....	112
8.8	Failure definition .....	112
8.8.1	Failure criteria .....	112
8.8.2	Failed components .....	113
8.9	Data documentation .....	113
8.10	Delivery .....	113
8.11	Packing, dispatching, handling and storage .....	113
<b>9</b>	<b>Solar cell protection diodes .....</b>	<b>114</b>
9.1	Overview .....	114
9.2	Testing, deliverable components and marking .....	114
9.2.1	Testing .....	114
9.2.2	Deliverable components .....	116
9.2.3	Marking .....	116
9.3	Production control (process identification document) .....	116
9.3.1	Integral protection diodes .....	116
9.3.2	External protection diodes .....	116
9.4	Acceptance tests .....	117
9.4.1	General .....	117
9.4.2	Integral protection diodes .....	117
9.4.3	External protection diodes .....	117
9.4.4	External and integral diodes .....	118
9.4.5	Test methods and conditions .....	118
9.4.6	Documentation .....	119
9.5	Qualification tests .....	119
9.5.1	General .....	119
9.5.2	Integral protection diodes .....	119
9.5.3	External protection diodes .....	120
9.5.4	Integral and external protection diodes .....	121
9.6	Test methods, conditions and measurements .....	122
9.6.1	General .....	122
9.6.2	Visual inspection (VI) .....	122
9.6.3	Dimensions and weight (DW) .....	123
9.6.4	Thermal cycling (CY) .....	124

---

9.6.5	Burn in (BI) .....	124
9.6.6	Humidity and temperature (HT) .....	124
9.6.7	Contact uniformity (CU) .....	125
9.6.8	Contact thickness (CT) .....	125
9.6.9	Surface Finish (SF) .....	126
9.6.10	Contact adherence (CA) .....	126
9.6.11	Pull test (PT) .....	127
9.6.12	Electron irradiation (EI) .....	127
9.6.13	Temperature annealing (TA) .....	128
9.6.14	Temperature behaviour (TB) .....	128
9.6.15	Diode characterization (DC) .....	129
9.6.16	Human body ESD (DE) .....	130
9.6.17	Switching test (DS) .....	130
9.6.18	Life test (DL) .....	133
9.7	Failure definition .....	135
9.7.1	Failure criteria .....	135
9.7.2	Failed components .....	135
9.8	Data documentation .....	135
9.9	Delivery .....	135
9.10	Packing, despatching, handling and storage .....	136
9.10.1	Overview .....	136
9.10.2	ESD sensitivity .....	136
<b>10</b>	<b>Sun simulators and calibration procedures .....</b>	<b>137</b>
10.1	Sun simulators .....	137
10.1.1	Spectral distribution .....	137
10.1.2	Irradiance uniformity .....	145
10.1.3	Irradiance stability .....	145
10.2	Standard cell and Sun simulator calibration .....	146
10.2.1	Primary standards .....	146
10.2.2	Secondary working standards (SWS) .....	147
10.2.3	Standards cells documentation .....	148
10.2.4	Maintenance of standards .....	149
10.2.5	Recalibration and intercomparison .....	149
10.2.6	Sun simulator calibration and maintenance .....	149
<b>11</b>	<b>Capacitance measurement methods .....</b>	<b>150</b>
11.1	Single junction solar cell capacitance measurement .....	150
11.1.1	Overview .....	150

---

11.1.2	Signal measurement method.....	151
11.1.3	Measurement procedure .....	151
11.1.4	Measurement analysis.....	155
11.1.5	Measurement of the capacitance of a multi-junction cell.....	158
11.2	Time domain capacitance measurement .....	159
11.2.1	Overview.....	159
11.2.2	Measurement procedure .....	159
<b>Annex A (normative) Source control drawing for photovoltaic assembly (SCD-PVA) - DRD.....</b>		
		<b>161</b>
<b>Annex B (normative) Source control drawing for solar cell assembly (SCD-SCA) - DRD.....</b>		
		<b>167</b>
<b>Annex C (normative) Source control drawing for bare solar cell (SCD-BSC) - DRD.....</b>		
		<b>172</b>
<b>Annex D (normative) Source control drawing for coverglass (SCD-CVG) - DRD .....</b>		
		<b>181</b>
<b>Annex E (normative) Source control drawing for External Protection Diodes (SCD-EPD) - DRD .....</b>		
		<b>187</b>
<b>Annex F (normative) Process identification document (PID) - DRD.....</b>		
		<b>191</b>
<b>Annex G (normative) Data documentation package (DDP) - DRD.....</b>		
		<b>193</b>
<b>Bibliography.....</b>		
		<b>196</b>
<b>Figures</b>		
Figure 4-1:	Specification hierarchy.....	25
Figure 6-1:	Definition of cell defects.....	64
Figure 6-2:	Test points for electrical performance measurement.....	66
Figure 7-1:	Definition of bare solar cell defects .....	84
Figure 8-1:	Methods of defining coverglass orientation.....	99
Figure 8-2:	Edge chip parameters.....	104
Figure 8-3:	Corner chip parameters .....	104
Figure 8-4:	Coverglass manufacturing tolerance limits .....	106
Figure 8-5:	Schematic for calculating surface resistivity .....	108
Figure 8-6:	Definition of coverglass flatness .....	109
Figure 9-1:	Diode forward and reverse test profile .....	132
Figure 9-2:	Diode switching test profile .....	133
Figure 11-1:	Solar cell impedance measurement equipment.....	152

Figure 11-2: Channel balancing and reduction of the parasitic inductances .....	153
Figure 11-3: Measurement of the resistance value of the shunt in the measuring conditions (shunt in parallel with the input of the network analyser).....	154
Figure 11-4: Small signal electrical schema biased with a DC voltage associated impedance .....	156

Figure C-1 : BSC front side .....	174
Figure C-2 : BSC rear side .....	175
Figure C-3 : BSC contact .....	175

## Tables

Table 4-1: Test tolerances on temperature .....	28
Table 5-1: Qualification test plan for PVA .....	39
Table 5-2: Acceptance test plan.....	44
Table 6-1: Qualification test plan for SCA .....	61
Table 6-2: Maximum dimensions of corner chips, edge chips and surface nicks .....	64
Table 7-1: Acceptance test matrix.....	78
Table 7-2: Qualification test plan for bare solar cells .....	81
Table 7-3: Maximum dimensions of corner chips, edge chips and surface nicks .....	84
Table 8-1: Qualification test plan for coverglasses.....	102
Table 9-1: Acceptance test matrix IPD.....	117
Table 9-2: Acceptance test matrix EPD .....	117
Table 9-3: Qualification test plan for integral protection diode .....	120
Table 9-4: Qualification test plan for external protection diodes .....	121
Table 9-5: Diode life test parameters .....	134
Table 10-1: AM0 solar spectral irradiance (WRC).....	138
Table 10-2: Classes of single and multi-source solar simulators .....	143
Table 10-3: Classes of solar simulators with respect to nonconformity of irradiance uniformity .....	145
Table 10-4: Classes of solar simulators with respect to temporal instability of irradiance ..	146
Table B-1 : Minimum current requirement for solar assemblies (25 °C or operating temperature) .....	169
Table C-1 : Electrical performance pass-fail criteria.....	177

---

## Introduction

---

The qualification, procurement, storage and delivery of space solar arrays are defined in the dedicated solar array specification, where requirements for the solar array electrical layout, structure and mechanism are specified.

This Standard outlines the requirements for the qualification, procurement, storage and delivery of the main assemblies and components of the space solar array electrical layout: photovoltaic assemblies, solar cell assemblies, bare solar cells, coverglass and protection diodes. This Standard does not outline the requirements for the qualification, procurement, storage and delivery of the solar array subsystem, comprising the solar panels, structural parts and mechanisms.

The general requirements are covered in the main part of this Standard (clauses 5 to 11). Annex A to Annex E specify the contents of the source control drawing of photovoltaic and solar cell assemblies, bare solar cells coverglasses and protection diodes and include the inspection data, physical and electrical characteristics, other ratings and acceptance and qualification specific requirements, which can be different for each space project.

This Standard is divided into five specific subjects, each one corresponding to each assembly or component:

- Clause 5 defines requirements for photovoltaic assemblies,
- Clause 6 for solar cell assemblies,
- Clause 7 for bare solar cells,
- Clause 8 for coverglasses,
- Clause 9 for protection diodes.

Two additional clauses are dedicated to Sun simulators and calibration procedures (clause 10 and capacitance measurement methods (clause 11).

# 1

## Scope

---

This Standard specifies the general requirements for the qualification, procurement, storage and delivery of photovoltaic assemblies, solar cell assemblies, bare solar cells, coverglasses and protection diodes suitable for space applications.

This standard does not cover the particular qualification requirements for a specific mission.

This Standard primarily applies to qualification approval for photovoltaic assemblies, solar cell assemblies, bare solar cells, coverglasses and protection diodes, and to the procurement of these items.

This standard is limited to crystalline Silicon and single and multi-junction GaAs solar cells with a thickness of more than 50  $\mu\text{m}$  and does not include thin film solar cell technologies and poly-crystalline solar cells.

This Standard does not cover the concentration technology, and especially the requirements related to the optical components of a concentrator (e.g. reflector and lens) and their verification (e.g. collimated light source).

This Standard does not apply to qualification of the solar array subsystem, solar panels, structure and solar array mechanisms.

This standard may be tailored for the specific characteristic and constraints of a space project in conformance with ECSS-S-ST-00.

## 2

# Normative references

---

The following normative documents contain provisions which, through reference in this text, constitute provisions of this ECSS Standard. For dated references, subsequent amendments to, or revision of any of these publications do not apply. However, parties to agreements based on this ECSS Standard are encouraged to investigate the possibility of applying the more recent editions of the normative documents indicated below. For undated references, the latest edition of the publication referred to applies.

ECSS-S-ST-00-01	ECSS system – Glossary of terms
ECSS-Q-ST-60	Space product assurance – Electrical, electronic and electromechanical (EEE) components
ECSS-Q-ST-70-06	Space product assurance – Particle and UV radiation testing for space materials
ECSS-Q-ST-70-09	Space product assurance – Measurements of thermo-optical properties of thermal control materials
ISO 15387:2005	Space Systems – Single junction space solar cells – Measurement and calibration procedures
ISO 14644-1:1999	Cleanrooms and associated controlled environments – Part 1: Classification of air cleanliness
MIL-E-12397B	Eraser, rubber pumice for testing coated optical elements
IEC 60749-26:2006	Semiconductor devices – Mechanical and climatic test methods - Part 26: Electrostatic discharge (ESD) sensitivity testing – Human body model (HBM)
ASTM D1193-99	Standard specification for reagent water
ESCC 23800 Issue 1	Electrostatic Discharge Sensitivity Test Method
ESCC 24900 Issue 2	Minimum Requirements for Controlling Environmental Contamination of Components
DIN 53289	Testing of adhesives for metals; floating roller peel test

# 3

## Terms, definitions and abbreviated terms

---

### 3.1 Terms from other standards

For the purpose of this Standard, the terms and definitions from ECSS-S-ST-00-01 apply, in particular for the following terms:

**qualification**

**verification**

### 3.2 Terms specific to the present standard

#### 3.2.1 General

##### 3.2.1.1 blistering

forming of multiple small air bubbles inside the perimeter of a finish layer

##### 3.2.1.2 bubbles

gaseous inclusion in the cell, coverglass or coverglass adhesive

##### 3.2.1.3 chip

local absence of material along the edges and corners of a complete component and which extend through the thickness of the component

##### 3.2.1.4 crack

fissure in the component with no separated portion from the remainder

**NOTE** Cracks can propagate from the edge of the material (edge cracks) or terminate at both ends within the material (surface cracks).

##### 3.2.1.5 delamination

physical separation between two material layers, which are joined in design

##### 3.2.1.6 discolouration

local variation of solar cell anti-reflection coating colour due to the influence of the structure orientation of the cell layer immediately below or the variation of the anti-reflection coating layer thickness

##### 3.2.1.7 dig

cavities in the surface of a component caused by impact with a pointed object or by crushing a material into the surface



**3.2.1.8 inclusion**

volume contained within the component that is devoid of the substrate material

**3.2.1.9 in-process testing**

tests performed during the manufacturing of a component or assembly in order to identify, in advance, defects or low performances

**3.2.1.10 nick**

local absence of material on the surface of a complete component which does not extend through the thickness of the component

**3.2.1.11 peeling**

forming of a delamination of a finish layer at the edge of the finished area. A blister at the edge of the surface

**3.2.1.12 procurement lot**

set of shipment lots of solar cells assemblies, bare solar cells and coverglasses, manufactured with the same processes and materials, with identical manufacturing lines, that fill the same purchase order

**3.2.1.13 scratch**

linear marking of the component that represents a volume devoid of the substrate material emanating from a single face of the component and not penetrating through the whole thickness of the substrate at any point

**3.2.1.14 shipment lot**

solar cell assemblies, bare solar cells and coverglasses manufactured with the same processes and materials with identical manufacturing lines delivered to the customer as a part of a purchase order

**3.2.1.15 spatter**

small bits of solid coating material imbedded on or in the coating or substrate

**3.2.1.16 voids**

absence of deposited materials

NOTE Examples are absence of cell contact material or anti-reflection coating.

**3.2.2 Photovoltaic assemblies****3.2.2.1 photovoltaic assembly**

power generating network comprising the interconnected solar cell assemblies (strings and sections), the shunt and blocking diodes, the busbars and wiring collection panels, the string, section and panel wiring, the wing transfer harness, connectors, bleed resistors and thermistors

**3.2.2.2 qualification coupon**

non-flight representative test sample of flight panels, built with flight processes and containing representative materials and components to be used in the manufacture of flight panels, formerly also called DVT coupon

### **3.2.2.3 slicing**

procedure to evenly distribute the total number of thermal cycles over temperature domains which are compatible with the temperature excursion on an orbit level rather than on the overall mission temperature envelope

NOTE Normally used for LEO missions.

## **3.2.3 Solar cell assemblies**

### **3.2.3.1 cladding**

application of a thin layer of material fully covering the surface, For instance silver cladding of an interconnector

### **3.2.3.2 deformed interconnector**

interconnector whose initial conformed shape is modified

### **3.2.3.3 interconnected cell**

solar cell with interconnector without coverglass

### **3.2.3.4 solar cell assembly**

solar cell together with interconnector, coverglass and, if used, by-pass diode

### **3.2.3.5 tearing interconnector**

interconnector physically separated from the cell due to a failure of the welding or soldering joint

## **3.2.4 Bare solar cells**

### **3.2.4.1 bare solar cell**

photovoltaic component capable to delivering electrical power when illuminated with light

### **3.2.4.2 component bare solar cell**

specially manufactured solar cell, with only one active junction and the same spectral response as one sub cell of a multi-junction solar cell

### **3.2.4.3 contact vacuum evaporation batch**

bare solar cells manufactured in the same contact vacuum evaporation run

### **3.2.4.4 drops**

excess of metallization material on the solar cell contacts

### **3.2.4.5 remaining Factor**

ratio of an electrical performance parameter at EOL to its value at BOL

NOTE E.g. maximum power of a solar cell.

### **3.2.4.6 solar cell anti-reflection coating**

single or multi-layer coating which reduces the reflection coefficient of the incident solar radiation

### **3.2.4.7 uncoated area**

area of the solar cell where the bare solar cell is exposed and is devoid of coatings

### **3.2.4.8 worm shaped bulge**

protuberance of contact material shaped in linear irregular paths or single dots where the contact material is locally delaminated from the immediate lower layer

## **3.2.5 Coverglasses**

### **3.2.5.1 coating**

dielectric or conductive material applied to the glass substrate by vacuum deposition

NOTE Coatings applied to the external face of the coverglass is termed the “front surface coating”. Coatings applied to the internal face of the glass substrate to be bonded to the solar cell is termed the “rear surface coating”. Commonly used coatings include:

- single-layer anti-reflection coating,
- multi-layer anti-reflection coating,
- ultraviolet reflector,
- infrared reflector, and
- conductive coating.

### **3.2.5.2 conductive coating**

transparent coating used to prevent the exposed surface from charging and consequently protecting the solar cell from the effect of electrostatic discharge

NOTE The coverglass usually comprises a suitable glass substrate and one or more of a combination of the coatings given in the note in clause 3.2.5.1.

### **3.2.5.3 coverglass**

glass substrate and coatings applied to its surfaces

### **3.2.5.4 coverglass coating lot**

collection of glass substrates subjected to the same coating run or runs (for coverglasses which have more than one coating)

### **3.2.5.5 infrared reflector**

multi-layer dielectric coating which has a high reflectance coefficient in the infrared portion of the solar spectrum

NOTE The infrared reflector is used to reflect light that is not usefully converted to electrical energy by the solar cell thus reducing the operating temperature and increasing the conversion efficiency of the SCA.

### **3.2.5.6 mark**

See **stain**

### **3.2.5.7 multi-layer anti-reflection coating**

multiple layer coating which has the effect of increasing the transmission coefficient of the coverglass

### **3.2.5.8 single layer anti-reflection coating**

simplest form of coating comprising a single layer of low index dielectric material which minimizes the reflection coefficient of the incident solar radiation thus increasing the transmission coefficient of the coverglass

NOTE The single layer of low index dielectrical material is usually done of  $MgF_2$ .

### **3.2.5.9 stain**

area which under inspection conditions can clearly be defined as not being optically homogeneous with the bulk material, and that cannot be categorized as an inclusion, scratch, crack, chip, dig, void or coating delamination

NOTE The term "mark" can be used as a synonymous.

### **3.2.5.10 ultraviolet reflector**

multi-layer dielectric coating which has a high reflectance coefficient in the UV portion of the solar spectrum

NOTE The ultraviolet reflector is used to protect the underlying adhesive and to reflect light that is not usefully converted to electrical energy by the solar cell thus reducing the operating temperature of the solar cell and increasing the conversion efficiency of the SCA.

### **3.2.5.11 uncoated area**

area of the coverglass where the bare coverglass substrate is exposed and is devoid of coatings

## **3.2.6 Verification processes**

### **3.2.6.1 accelerated testing**

test in which the life time requirement is verified in an accelerated way by intensifying one parameter of the environment or load.

NOTE The following are examples of accelerated tests:

- UV test done with increased sun intensity in the UV part of the spectrum,
- Electron and proton radiation tests with life time fluences in a limited period of time,
- humidity tests done at higher temperature and humidity,
- bake-out done at higher temperature,
- performance parameter degradation at higher temperature,

- thermal cycling with higher/lower cool-down and heat-up rates and without nominal operating dwell time in between.

### 3.2.6.2 acceptance test

test to determine that a system, subsystem, component or functional part is capable of meeting performance requirements prescribed in purchase specifications or other documents specifying what constitutes the adequate performance capability for the item and to demonstrate the item is free from manufacturing defects

NOTE In this document acceptance is associated with specified requirements which have a defined acceptance safety factor with respect to requirements corresponding with the actual loads and environments

### 3.2.6.3 delta qualification

qualification performed on an equipment which has undergone minor design modifications or has been qualified to operate in environments less severe than those specified

### 3.2.6.4 proto flight test

test requirements which have a defined qualification safety factor with respect to requirements corresponding with the actual loads and environments, but with limited test durations

### 3.2.6.5 qualification by similarity

process to demonstrate the ability to fulfil specified requirements by comparing a new design specification with a similar proven design specification

## 3.3 Abbreviated terms

For the purpose of this standard, the abbreviated terms of ECSS-S-ST-00-01 and the following apply:

Abbreviation	Meaning
ADP	acceptance data package
AOCS	attitude and orbit control system
AM0	air mass 0 (zero)
APTC	ambient pressure thermal cycling
AR	anti-reflection
ARC	anti-reflection coating
ATOX	atomic oxygen
BOL	beginning-of-life
BSC	bare solar cell
BSR	back surface reflector
CIC	connector integrated cell

NOTE: U.S. designation of SCA.

---

<b>Abbreviation</b>	<b>Meaning</b>
CIDL	configuration item data list
CVCM	collected volatile condensable material
CVG	coverglass
DCR	documentation change request
DJF	design justification file
DRD	document requirements definition
DRB	delivery review board
DVG	direct voltage gradient
DVT	design verification test
EMC	electromagnetic compatibility
EOL	end-of-life
ESD	electrostatic discharge
FIT	failure in time
FMECA	failure modes, effects and criticality analysis
GaAs	gallium arsenide
GEO	geostationary orbit
IC	interconnected cell
$I_{mp}$	maximum power current
$I_{op}$	current at operational voltage
IRR	infrared reflector
$I_{sc}$	short-circuit current
IVG	inverted voltage gradient
LEO	low Earth orbit
LVDT	linear voltage displacement transducer
MLAR	multi-layer anti-reflection coating
NCR	nonconformance report
NRB	nonconformance review board
OSTC	on station thermal cycling
PAD	part approval document
PCDU	power control and distribution unit
PID	process identification document
$P_{max}$	maximum power
PMCF	product manufacturing and control file
PMP	parts, materials and processes
PTH	power transfer harness
PVA	photovoltaic assemblies
r.m.s.	root mean square
RAMS	reliability, availability, maintainability and safety

---

<b>Abbreviation</b>	<b>Meaning</b>
RDC	relative damage coefficients
RML	recovered mass loss
S.C.	solar constant
S.C. (AM0)	solar constant at air mass 0
SCA	solar cell assembly
SCD	source control drawing
SLAR	single layer anti-reflection coating
SWS	secondary working standard
TAT	type approval test
TBD	to be defined
TBS	to be specified
TML	total mass loss
UVR	ultraviolet reflector
$V_{mp}$	maximum power voltage
$V_{oc}$	open-circuit voltage
$V_{op}$	operational voltage
$V_{test}$	test voltage
WRC	World Radiation Centre in Davos

---

# 4 General

---

## 4.1 Overview

### 4.1.1 Objective and organization

The objectives of this Standard are:

- To define the rules for the flow of technical requirements from a project solar array specification down to component level in order to guarantee that lower level components and sub-assemblies are qualified according to specifications.
- To define the set of requirements from component level up to photovoltaic assemblies (PVA) to enable a generic qualification for each level of assembly for about 90 % of the solar array applications within a certain range; for example, deployable solar arrays for GEO or LEO.

This clause describes the organization of the requirements and how they are applied.

The philosophy behind this Standard is two fold in that respect that:

- Qualification of a specific level of assembly is based on the use of qualified components and sub-assemblies at lower levels. The specification hierarchy that photovoltaic assemblies and their components form part of is illustrated in Figure 4-1.

OR

- Qualification of components for a specific application can be achieved at a sub-assembly level at which the qualification is unequivocally demonstrated. This means that certain types of qualification tests do not need to be duplicated at different level of assembly in case of a unique application of a dedicated design

This Standard defines the requirements for qualification at each level from components up to and including PVA on coupons. Coupons are built according to PVA design requirements with the objective of demonstrating that the design and manufacturing processes are ready for use on solar panels of a flight application.

For many parameters in this standard the value to be specified as requirement is dependent on the mission concerning duration and environmental conditions or the implemented solar array design. These parameter values are derived from the higher level subsystem specification and reflected in a dedicated



document. In this standard the source control drawing has been selected generically on every level of assembly as an example of a document to reflect the specific requirements. So the source control drawing or equivalent set of documentation is the reference list for physical characteristics, performance requirements and environmental conditions.

Full qualification for an application is not only achieved after successful qualification of the PVA and its components on coupon level. Robustness against some environments can only be demonstrated in the final solar array configuration, that may comprise amongst others full size panel on-station thermal cycling and sine vibration, acoustic noise, and wing deployment testing at subsystem or spacecraft level.

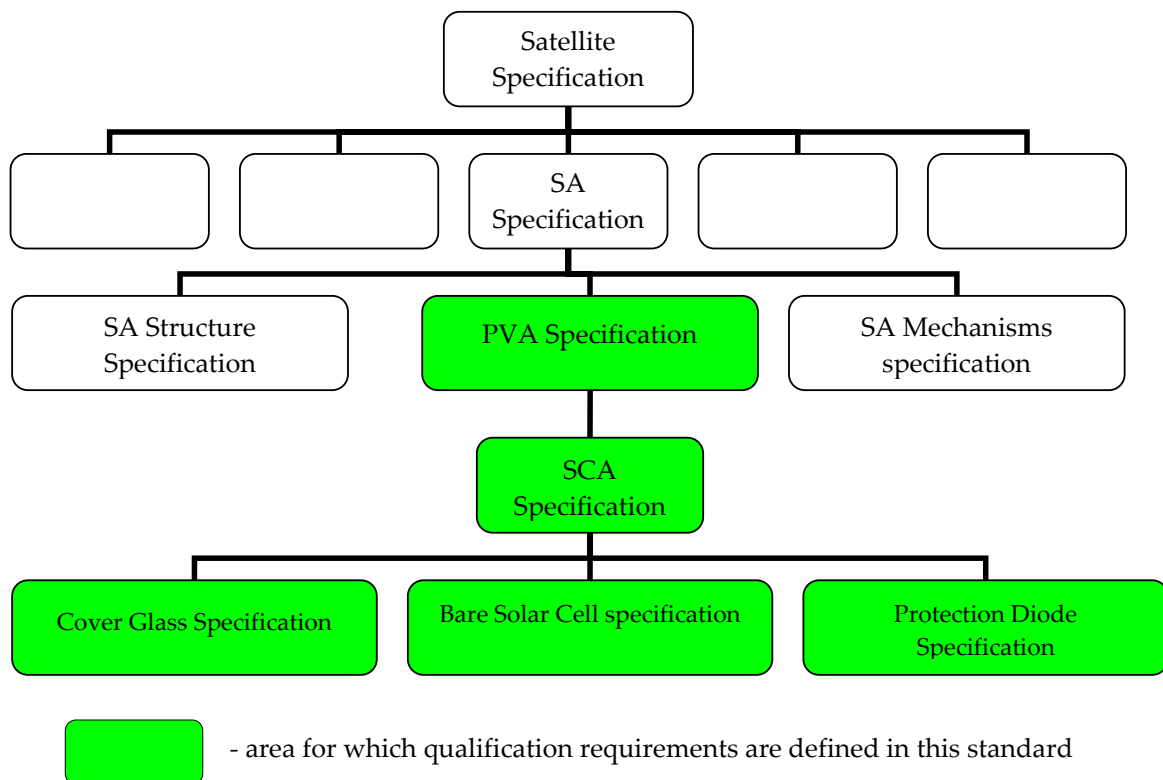

**Figure 4-1: Specification hierarchy**

### 4.1.2 Interfaces with other areas

In the specification hierarchy (Figure 4-1) only the components and assembly levels that are usually dedicated to solar arrays are shown. At every integration step, additional materials and components, not mentioned in the specification hierarchy, are used such as:

- adhesives,
- solder,
- interconnectors and busbars,
- diodes,

- resistors,
- thermistors,
- connectors, and
- wires.

Requirements for these materials and components can be found in their procurement specifications, and in EEE component specifications, which are reviewed as part of the qualification process. For EEE component specifications, see the ECSS-Q-ST-60 series of standards. For Materials Parts and processes specifications, see the ECSS-Q-ST-70.

The qualification of the use of these items is a pre-requisite for the qualification of the assembly they are part of (for example, coverglass adhesive at the SCA level and busbars at the qualification coupon level).

Non-PVA related solar array design, power subsystem interface and mission specific related topics such as grounding, electromagnetic compatibility, magnetic moment, spacecraft related geometrical loss factors and end-of-life performance prediction related topics, including loss factors, are not addressed in this Standard.

Specific design measures to support the solar array in order to satisfy the requirements of this Standard, such as grounding spots and blocking diodes, are however, taken into account.

Specific environmental conditions which can be a limitation in the qualification for general use, are not addressed in this Standard as these aspects are usually the subject of a project dedicated qualification (for example, the chemical contents in local ambient air).

## 4.2 Physical properties

- a. The following physical properties of the components and materials shall be measured:
  1. coefficient of thermal expansion
  2. heat conductivity
  3. specific heat
  4. Young's modulus and Poisson's ratio
  5. Flex strength

NOTE The objective is to establish the boundaries for the qualification test program over the full range of application by means of analysis.

- b. The data specified in requirement 4.2a shall be determined during the development phase of a new component and need not be repeated during the qualification program.

## 4.3 Test and storage

### 4.3.1 Test environment

- a. The atmospheric conditions during all inspection, test operations and storage shall be as follows:

1. Pressure: (1013,25 ± 33) hPa.
2. Temperature: (23 ± 5) °C.
3. Average relative humidity: 40 % - 60 %.

NOTE A pressure of (1013,25 ± 33) hPa is equivalent to (760 ± 25) mmHg.

- b. The room cleanliness level should be airborne particle count: Class 8 ISO 14644-1.
- c. Every deviation from requirements 4.3.1a and 4.3.1b during tests shall be recorded in the data documentation package (DDP).

NOTE 1 For DDP complete contents, refer to Annex G.

NOTE 2 Semiconductor devices (i.e. planar diodes) can short-circuit if no special precautions are taken during long storage periods under certain atmospheric conditions. This is because chlorine content, in combination with illumination, can produce metal contact migrations on these semiconductor devices.

### 4.3.2 Test tolerances and accuracies

- a. The accuracy of the instruments and test equipment used to control or measure test parameters shall be one order of magnitude higher than the tolerance on the variable to be measured.

NOTE Examples of where this cannot be achieved include measurements of electrical performance and temperatures.

- b. All instrumentation used for qualification and acceptance tests shall:
1. be calibrated, and
  2. be within the specified calibration period at the time of test.
- c. Instrumentation whose calibration period runs out during the planned test time shall not be used.
- d. The maximum test temperature tolerances for thermal testing shall be as given in Table 4-1.
- e. The accuracy of mass measurements shall be better than ±1 % or 0,01 g, whichever is higher.
- f. The test condition tolerances shall be applied to the nominal test values specified.

- g. The accuracy of the electrical performance test on PVA level shall be better than or equal to the calibration loss factor used in the power analysis.

**Table 4-1: Test tolerances on temperature**

Temperature range (°C)	tolerance (°C)
around - 175	-10 / +0
around - 100	-10 / +0
around + 90	-0 / +10
Around +130	-0 / +10

### 4.3.3 Margins

- a. The margins to be applied to qualification test conditions shall be as defined in the solar array specification.

## 4.4 Critical materials

- a. The critical interface information shall be part of the PMP list.

NOTE For PMP, see ECSS-Q-ST-70 Annex B.

- b. Silver cladding shall be annealed and contain a minimum of 99,9 % pure silver.
- c. Pure tin, cadmium and zinc shall not be present in finished space-qualified solar panels.

NOTE Pure tin refers to a tin alloy with less than three atomic percent of an alloying metal, e.g., lead. Pure cadmium and zinc is defined as these metals used or applied in a non-mixed metal or unalloyed state.

- d. Solar panels containing Beryllium Oxide shall be clearly identified with the designation BeO.

# 5

## Photovoltaic assemblies

---

### 5.1 Overview

#### 5.1.1 Description

The photovoltaic assembly (PVA) comprises the electrical parts to satisfy the requirements of the solar array specification.

This Clause applies to solar arrays using a planar design without concentration and based on crystalline solar cells.

In case of concentration, this Clause applies to the PVA without the optics, provided that the electrical performance tests are adapted to the light incidence and intensity imposed by the optics.

Usually, a PVA consists of parallel connected strings. A string is the smallest operational component at the PVA level. A string consists of a series interconnected solar cells connected to the spacecraft bus. These strings are supported by a solar array panel substrate or frame.

The parts comprising a PVA usually include:

- interconnected SCAs,
- bleed resistors,
- wiring,
- panel connectors,
- diodes (blocking and shunt),
- thermal sensors,
- telemetry indicator wiring, and
- grounding.

#### 5.1.2 Purpose and objective

In this Clause the design limits, including margins, and the responsibilities for PVA manufacturing are defined and include the:

- design requirements (refer to clause 5.3);
- mechanical and electrical interface;
- manufacturing requirements for PVA (refer to clause 5.4);

- qualification requirements for PVA (refer to clause 5.5.1);
- acceptance requirements for PVA (refer to clause 5.5.2).

The values specified for the SCA level are provided by the solar cell assembly supplier and confirmed during the SCA qualification tests (refer to clause 6.4).

In order to design and verify a solar array, data for the following parameters and characteristics at the SCA level or lower are used:

- characteristics of the SCA ( $V_{oc}$ ,  $I_{sc}$ ,  $V_{mp}$  and  $I_{mp}$ );
- spectral response;
- reference calibration standard;
- relative damage coefficient and electron-proton equivalence;
- temperature coefficients as a function of radiation fluences;
- reverse characteristics versus temperature;
- UV and Sun spectrum characteristics (reflectivity);
- capacitance versus temperature;
- optical properties (hemispherical emissivity, and solar absorptance, and cover gain or loss);
- behaviour with regard to specific mission environments:
  - ATOX sensitivity,
  - thruster erosion sensitivity,
  - micro-meteoroids and debris sensitivity;
- loss factors for interconnecting the cells into a string.

## 5.2 Conditions and method of test

- a. The conditions and methods of testing shall conform to the photovoltaic assembly source control drawing (SCD-PVA).

NOTE The PVA specification consists of two parts, the generic specification (this Standard) and the SCD. For the preparation of the SCD-PVA, refer to Annex A.

- b. The SCD-PVA shall be prepared by the supplier, in conformance with Annex A, and provided to the customer for reviewing and agreement.
- c. Any deviation from in-process, acceptance and qualification test shall be justified.
- d. Deviations from this Standard applicable to the SCD-PVA shall:
1. be agreed between the customer and the supplier;
  2. include alternative requirements equivalent to those of this Standard;
  3. not affect the reliability and performances of the photovoltaic assemblies;
  4. be only those specified in requirement 5.2c.

## 5.3 Photovoltaic assembly design

### 5.3.1 Overview

The objective of this standard at the PVA level is to specify the requirements for the detail design, performance, qualification, manufacture and acceptance testing of coupons equipped with the PVA. The inputs to these requirements are the solar array specification, which is prepared following the requirements of the mission specification, the ground test programme and the spacecraft design. In this clause the steps which influence specific design characteristics of the PVA have been listed. Requirements which merely determine the sizes of the PVA have not been taken into account, like intensity related loss factors and reliability requirements.

### 5.3.2 Parameters related to parts, materials and processes (PMP)

#### 5.3.2.1 Outgassing

- a. Flight hardware shall be constructed from space qualified materials having the following properties:

1. A recovered mass loss (RML) of 1 % or less.

NOTE See ECSS-Q-ST-70-02.

2. A collected volatile condensable material (CVCM) of 0,1 % or less when heated in a vacuum to 125 °C and collected at 25 °C.

- b. The PMP list shall include the RML and CVCM values for all materials used.

NOTE The mission specification can specify an absolute limit to the total mass loss and volatile condensable material of the solar array sub-system. The fulfilment of this system requirement can be verified either by analysis using the total amount of the applied materials, the individual material RML and CVCM data, outgassing field of view and temperature distribution, or by test of the representative subsystem and measurement of the outgassing product.

#### 5.3.2.2 Toxicity

- a. Any material used in the construction of the PVA that is dangerous to the health of the personnel shall be identified.
- b. Preventive handling measures shall be taken in conformance with a standard approved by the customer.

### **5.3.2.3 Flammability**

- a. Any flammable materials used in the construction of the PVA shall be identified.

### **5.3.2.4 Corrosion**

- a. The supplier and customer shall agree on the measures to be taken to prevent corrosion during storage or in normal operational service.
- b. Standard atmospheric conditions may be assumed for general applications in the spacecraft, over a period of time that is agreed between the supplier and customer.
- c. To avoid electrolytic corrosion, a process, approved by the customer, shall be used.

### **5.3.2.5 Magnetism**

- a. Permanent magnetic materials shall be avoided when specified by the mission.
- b. Non-magnetic materials should be used.

### **5.3.2.6 Erosion**

- a. PVA materials shall be capable of tolerating a defined erosion level resulting from spacecraft operation without degradation in the nominal performance of the PVA, in conformance with the PVA specification.

NOTE Example: thruster plumes.

### **5.3.2.7 Atomic oxygen (ATOX)**

- a. PVA materials shall be capable of tolerating a defined level of degradation resulting from an ATOX environment, without degradation in the nominal performance of the PVA, in conformance with the solar array specification.
- b. The ATOX resistivity shall be determined by the individual resistivities of the used materials and components in their configuration.

## **5.3.3 Parameters related to design**

### **5.3.3.1 Cell integration**

- a. The solar cells shall be structured such that the PVA is capable of withstanding all phases of ground handling, transportation, qualification testing and acceptance testing, launch and orbit operations as to conform to the mission requirements.
- b. The capability for replacement of cracked, broken or damaged SCAs shall be included in the design.
- c. Repair method shall be feasible in horizontal and vertical panel positions.



### 5.3.3.2 Stringing

- a. If blocking diodes are applied in the design at the panel level, the positive end of the strings shall be connected to the panel connector by a blocking diode.
- b. To enable performance measurement at the lowest level of assembly at the coupon level, strings shall be measured individually.
- c. Potential parallel connections shall not prevent performance measurement specified in requirement 5.3.3.2b.
- d. If the dimensions of the coupon enables the accommodation, the full flight string length shall be represented on the qualification coupon.
- e. Coupon layout shall be as defined in a overall assembly drawing as part of the SCD-PVA.

### 5.3.3.3 Cell interspacing

- a. The cell interspacing shall be compatible, as a minimum, with the following mission requirements:
  1. thermal expansion and contraction within the mission temperature extremes specified in the solar array specification;
  2. panel geometry;
  3. ESD requirements.

### 5.3.3.4 Sectioning

- a. Sections shall not be included at the coupon level.
- b. To test the technique of interconnecting strings, the negative ends of individual strings may be connected in a way that is representative for flight panels.

### 5.3.3.5 Reverse bias protection

- a. The solar cells that are potentially subject to reverse bias shall be protected by shunt diodes unless the solar cells are insensitive to the effects of reverse bias.

NOTE Types of reverse bias include:

- AOCS failure shadowing,
- self shadowing, and
- power management (including maximum power point tracker when direct energy transfer function is acting at BOL).

### 5.3.3.6 Insulation

- a. The following items shall be electrically insulated from each other:
  1. Any solar cell circuits to substrate (the grounding reference of the coupon).

2. Solar cell circuits to solar cell circuits (if not connected at the negative ends).
3. Thermal sensor to the solar cell circuits and to the substrate (the grounding reference of the coupon).
4. Conductive coverglass grounding network, if used, to solar cell circuits.

#### **5.3.3.7 Derating**

For the derating requirements of components, see ECSS-Q-ST-30-11.

#### **5.3.3.8 Redundancy**

For redundancy requirements, see ECSS-Q-ST-30.

For failure modes requirements, see ECSS-Q-ST-30-02.

#### **5.3.3.9 Fault tolerance**

- a. A FMECA shall be performed for the design of the solar array.
- b. The design consequences shall be implemented on the qualification coupon, including:
  1. the photovoltaic assembly from solar cell strings to the connector, and
  2. redundant bleed resistors and, if any, redundant PVA assemblies or components.

NOTE 1 Examples: Solar cell strings, blocking diodes, temperature sensors.

NOTE 2 For FMECA, see ECSS-Q-ST-30-02.

- c. No single fault shall result in the following:
  1. The loss of integrity of the redundant parts indicated in requirement 5.3.3.9b.2.
  2. The propagation of the fault causing permanent damage or loss of use of the units connected to the PVA.

NOTE Examples: solar array regulator unit, solar array drive mechanism.

- d. No failure shall be propagated from one solar array wiring group to another.

#### **5.3.3.10 Fatigue resistance**

- a. The effects of fatigue shall be verified by analysis or test.
- b. The design of the PVA shall include the result of the verification specified in requirement 5.3.3.10a.

### **5.3.3.11 Adherence to substrate**

#### **5.3.3.11.1 Measurement**

- a. The adherence of SCAs to the substrate shall be measured using representative process samples.

#### **5.3.3.11.2 Property**

- a. The SCAs shall stay attached to the panel and conform to all requirements during the test campaign and all the phases of the mission.
- b. The adherence shall be such that the SCAs integrated on the substrate can be repaired, removed and replaced.

### **5.3.3.12 Adhesive uniformity**

- a. The thickness boundaries, including manufacturing and repair tolerances, shall be defined by means of analysis or test.
- b. The boundary requirements on minimum and maximum thickness, in conformance with requirement 5.3.3.12a, shall be guaranteed by a controlled application process demonstrated on separate samples.
- c. The thermal conductance towards the panel substrate shall be such that the specified solar cell and protection diode temperature can be maintained.

### **5.3.3.13 Electrostatic discharge (ESD)**

- a. The solar array design shall be such that it can survive the charging environment and operating conditions defined by the mission.
- b. Requirement 5.3.3.13a shall be either demonstrated by analysis or by testing.

NOTE During and after launch, the spacecraft is surrounded by a low density plasma of high energy electrons and protons. On insulated surfaces of the spacecraft, the electrons build up a charge which discharges when breakdown of the insulating materials is reached.

### **5.3.3.14 Electromagnetic compatibility (EMC)**

- a. The PVA shall be designed to meet the specific EMC requirements stated in the SCD-PVA.

### **5.3.3.15 Repairability**

- a. The capability of repairing, removing and replacing items down to component level shall be provided.

NOTE For example, for single SCAs, diodes, thermal sensors, wires and connectors.

## 5.4 PVA manufacturing

### 5.4.1 Process validation

- a. The manufacturing and integration processes shall be validated for all the project specific design configurations and to meet the engineering design requirements.

### 5.4.2 Defect acceptability

- a. The acceptability of defects at the PVA level shall be:
  1. agreed with the customer;
  2. defined in a production control document;
  3. validated by qualification testing.

### 5.4.3 In-process testing

#### 5.4.3.1 Overview

The in-process tests are performed during the manufacturing of the PVA to detect deviations and defects as early as possible. This clause 5.4.3 lists the test to be performed during the manufacturing of the PVA.

#### 5.4.3.2 Mass measurement

- a. To determine the add-on mass of the SCA laydown process, the mass of the substrate shall be measured before and after the substrate is equipped with the SCA's and be in conformance with SCD-PVA.

#### 5.4.3.3 Wet insulation test

- a. A wet insulation test shall be performed by the supplier to prove the integrity of the bare coupon insulation layer, as follows:
  1. Verify continuity between the conductive layer under the insulation to the test connection point.
  2. For the wet insulation test, use ethyl, isopropyl alcohol, or otherwise an equivalent fluid agreed with the customer, as contact fluid during the measurements.
  3. Apply a voltage which corresponds to the breakthrough value for short term exposure of the applied insulation material ( $E_{\text{spec}}$  V/ $\mu\text{m}$ ) times the minimum guaranteed thickness.

NOTE For example, for  $E_{\text{spec}} = 20$  V/ $\mu\text{m}$  and a  $(50 \pm 10)$   $\mu\text{m}$  insulation layer, a test voltage of 800 V applies.

- b. The acceptance criteria shall be an insulation larger than 100 M $\Omega$ .
- c. In case of a failure, the coupon insulator layer shall be repaired.

#### 5.4.3.4 Adherence to substrate

- a. The adherence of the SCAs to the substrate, shall be performed in parallel to panel laydown.
- b. The adherence to substrate shall be verified by means of one of the following two methods:
  1. Method 1
    - (a) Bond 3 SCAs following identical process to a representative PVA substrate of the following dimensions: 200 x 130 mm.
    - (b) After 1 week at room temperature, perform a pull test, with a pull force equal or larger than 1 N/cm<sup>2</sup>.
  2. Method 2
    - (a) In case no solar cell assemblies and substrate are available, bond together 2 Kapton foils of the same material as used in representative PVA and with dimensions of 250 mm x 150 mm.
    - (b) After 1 week at room temperature, perform a peel test of the foil according to DIN 53289.
    - (c) Use a peel force equal or larger than 1,8 N/cm.
    - (d) Ensure that the separation takes place within the adhesive for an area larger than 50 %.

#### 5.4.3.5 Visual inspection

- a. A visual inspection shall be made after stringing.

NOTE This is to determine, as early as possible, defects in the rear sides of solar cells and, when feasible, the front sides.
- b. The visual inspection procedure and criteria shall be agreed with the customer and be described in the SCD-PVA.

#### 5.4.3.6 Continuity check

- a. The continuity of all strings shall be checked after stringing, in order to detect defects not detected during the visual inspection.
- b. Continuity of harness, wires and diodes shall be checked, and measured after final assembly.
- c. The maximum values of resistance shall be given in the SCD-PVA.

#### 5.4.4 Identification and traceability

- a. Components other than SCAs, bare cells and coverglasses shall be identified in conformance with the traceability requirements of Class 1 components, and PAD DRD of ECSS-Q-ST-60.

NOTE For requirements on the identification and traceability of parts and materials, see clauses 6.1.4,

7.1.3 and 8.3.3 for SCAs, bare cells and coverglass, respectively.

### **5.4.5 Recording**

- a. Before start manufacturing, all processes and process variables related to PVA manufacturing that have impact on the performance of the process, shall be identified by the supplier.
- b. The processes variables specified in requirement 5.4.5a shall be recorded during manufacturing.

## **5.5 PVA tests**

### **5.5.1 Qualification tests**

#### **5.5.1.1 Purpose**

Qualification tests are performed to check and qualify the design requirements.

#### **5.5.1.2 Process**

- a. Qualification tests shall be preceded by the acceptance tests as listed in clause 5.5.2, in order to be representative of the life of flight hardware.
- b. All results of the qualification test shall be reported in a qualification test report.
- c. Qualification margins shall not exceed component and material specifications unless agreed between supplier and customer.
- d. The following environmental test shall be performed for qualification of PVAs as applied on solar panels:
  1. Fatigue thermal cycling test on the qualification coupon.
  2. Humidity test performed on dedicated test sample if not tested on SCA level.
  3. ESD test on a dedicated ESD coupon, if specified by the solar array requirement specification.
  4. Erosion of materials, due to thruster plume if specified by the solar array requirement specification.

NOTE The tests to be performed for each qualification are listed in Table 5-1 and described in clauses 5.5.2 and 5.5.3.

- e. In cases where the same coupon is used for the fatigue thermal cycling test and the humidity test, in conformance with requirement 5.5.1.2d the humidity test sequence shall precede the fatigue thermal cycling test sequence.

- f. Except in conformance with requirement 5.5.1.2e, each type of test shall be performed on a dedicated qualification coupon built specifically for the test.
- g. The qualification coupon need not be the same size as the flight panels, but shall contain a representative number of components to enable reliable verification of flight panel processes and materials.
- h. The processes used to build the qualification coupon shall be documented in a parts, materials and process (PMP) list to ensure that the flight panels are built with identical processes, materials and configurations.
- i. Each qualification coupon shall be flight representative as far as allowed by the dimensions of the qualification coupon
- j. Facilities shall be available to safely store the qualification hardware (included failed samples) for a minimum of 6 years (equivalent to five years in storage and one year in orbit).

**Table 5-1: Qualification test plan for PVA**

Check	Fatigue thermal cycling	Humidity test	ESD test
Full visual inspection (5.5.3.2)	1, 6, 9, 14	1, 5	1, 4
Electrical health check and performance (5.5.3.3 and 5.5.3.4)	2, 7, 10, 15	2, 6	2, 5
Capacitance (5.5.3.5)	3, (11), 16		
X-ray photo (5.5.3.9)	4, (12), 17		
Reflectance (5.5.3.8)		3, 7	
Vacuum thermal cycling (5.5.3.11)	5, 13		
Substrate integrity (5.5.3.10)	18		
Fatigue thermal cycling (5.5.1.3)	8		
Humidity (5.5.1.4)		4	
ESD test (5.5.1.5)			3
NOTE: The numbers in each column indicate the sequence in which the checks are performed for each test.			

### 5.5.1.3 Fatigue thermal cycling test

#### 5.5.1.3.1 Purpose

The purpose of the thermal cycling test is to demonstrate the life fatigue compatibility of all components and processes in an assembly.

#### 5.5.1.3.2 General

- a. The PVA manufacturer shall demonstrate that lack of continuity is avoided at any time during cycles defined in requirement 5.5.1.3.4g, both on the solar cell and on the protection shunt diode circuits.

- b. The test conditions, specifically the thermal gradients through the test sample thickness, shall be representative of the distribution predicted in space so that the components are not over-stressed or under-stressed beyond specified limits.
- c. The temperature extremes of the thermal cycling shall be extended or a dedicated structural test shall be performed in cases where analysis demonstrates that the structural loading results in a greater stress than the thermal cycling.

NOTE For example, acoustic and noise can produce greater stress than thermal cycling in certain missions.

#### 5.5.1.3.3 Qualification coupon

- a. The qualification coupon shall be defined by means of a representative drawing, document or matrix in the SCD-PVA.
- b. The representation of the critical areas of the solar array on the qualification coupon shall be agreed with the customer.

NOTE For example, the substrate represents a worst-case stress part of the flight panels.

- c. The qualification coupon shall be manufactured using the same qualified materials and processes as the flight panel, and any deviation shall be identified by the PVA supplier.
- d. The qualification coupon shall contain only one PVA technology.
- e. The number of (non-cell) components shall correspond to the number in a flight configuration of the unit they belong to, but with a minimum of two.

NOTE For example, it can be one blocking diode per string, one shunt diodes per shunt interval, and two bleed resistors per panel, but in accordance with this requirement, in all these cases the minimum number is two.

- f. If space is available, additional components may be included to be tested as separate items.
- g. For every type of solar cell configuration (N-end tab, P-end tab or middle cell) one piece shall be repaired on the coupon after the acceptance test (only visual inspection and electrical health check), unless configurations are identical, in which case at least two cells shall be repaired.
- h. The production of the qualification coupons shall be representative of the full processing of the flight hardware.
- i. At least 3 thermocouples on the front side and 3 on the rearside of each qualification coupon shall be placed for temperature monitoring.
- j. The qualification coupon subjected to the fatigue thermal cycling test need not follow the acceptance test sequence.



- k. Dedicated electrical test points shall be included in the electrical design of the qualification coupon such that the capacitance of single strings can be measured.

#### 5.5.1.3.4 Test

- a. The number of cycles and temperature deltas may be determined using one of the following criteria:
  - 1. The number of cycles is four times the number of cycles that occur during the mission with 0 °C temperature delta (at both upper and lower design temperature limit).
  - 2. The number of cycles is equal to 1,5 times the number of cycles occurring during the mission with a temperature delta of 10 °C at extremes (both upper and lower qualification temperature limit).
- b. If qualification margin temperature exceeds the brittle point of main elements of the PVA, the option to be used in conformance with requirement 5.5.1.3.4a shall be agreed with the customer.
- c. For a GEO mission, the following cycling profiles shall be used:
  - 1. Define GEO transfer orbit cycles in conformance with the mission profile.
  - 2. all on station representing fatigue cycles are identical”.
- d. For a LEO mission, the following cycling profiles shall be used:
  - 1. A temperature profile which envelopes the variation of temperature extremes during the mission.
  - 2. The total profile, divided into a number of equally shaped sub-profiles, where the number of sub-profiles are:
    - (a) equal to the number of years of the mission, and
    - (b) with extreme cycle temperatures derived from the slicing of the temperature profile of the whole mission.
- e. The number of cycles and temperature limits of requirements 5.5.1.3.4a and 5.5.1.3.4b shall be stated in the SCD-PVA.
- f. Monitoring of the insulation between the solar cell circuit and the substrate shall:
  - 1. be performed in conformance with clause 5.5.3.3.3, and
  - 2. take place during the cycles with the maximum temperature limits and for a minimum of two cycles at each test interval.
- g. Monitoring of the continuity of the solar cell circuits shall:
  - 1. be performed in conformance with clause 5.5.3.3.2,
  - 2. take place during cycles for the complete activity,
  - 3. be performed on a regular, at least daily basis for a number of cycles, such that:
    - (a) during 10 % of these cycles of the cell circuit, and

- (b) during 90 % of these cycles on the protection diode network shall be monitored.
- 4. be performed by measuring both cell circuit continuity, at the beginning and at the end of the cycles in conformance to the relevant percentage specified in requirement 5.5.1.3.4g.3.
- h. Insulation and continuity shall not be measured simultaneously.

#### 5.5.1.3.5 Pass-fail criteria

- a. On completion the test, the following conditions shall be met:
  - 1. there is electrical continuity (no open circuit), and
  - 2. the power output of the test coupon and the insulation is within the limits stated in the SCD-PVA.

### 5.5.1.4 Humidity

#### 5.5.1.4.1 Purpose

The purpose of the humidity test is to demonstrate the endurance of assembled PVA components in a real-life environment against standard environmental conditions using accelerated tests.

#### 5.5.1.4.2 General

- a. If there are requirements on specific environmental conditions, they shall be stated in the SCD-PVA.

NOTE For example, chemical vapour requirements.

#### 5.5.1.4.3 Test Sample

- a. The test sample shall be manufactured using the same qualified materials and processes as the flight panels.
- b. The production of the test sample shall be representative of the full processing of the flight hardware.

#### 5.5.1.4.4 Test

- a. The test sample shall be placed in a chamber at ambient pressure.
- b. The chamber temperature shall then be increased to 60 °C minimum.
- c. Relative humidity shall be higher than 90 %.
- d. The duration of the test shall be 30 days.
- e. In the case of solar cells with aluminium content window layers, the HT test shall be extended to simulate on-ground expected duration and humidity and temperature conditions.
- f. High-purity water in conformance with ASTM D1193-99, Type I, shall be used.
- g. Water condensation on the surface of the test sample shall be prevented.
- h. If there are requirements on specific environmental conditions, they shall be stated in the SCD-SCA.

NOTE For example, requirements on chemical vapour conditions.

#### 5.5.1.4.5 Pass-fail criteria

- a. On completion the test, the following conditions shall be met:
  1. there is electrical continuity (no open circuit), and
  2. the power output of the test coupon and the insulation is within the limits stated in the SCD-PVA for the specified temperatures.

### 5.5.1.5 Electrostatic discharge (ESD) test

#### 5.5.1.5.1 Purpose

The purpose of the ESD test is to demonstrate that the use of adequate design rules reduces the risk of ESD. This is done by demonstrating that ESD primary discharge does not lead to a self-sustained secondary arc, which can lead to loss of permanent power or insulation in the solar array.

The tests are performed on solar array coupons using instrumentation specially designed for that purpose.

Typical rules and a test procedure are described in ECSS-E-ST-20-06.

#### 5.5.1.5.2 Pass-fail criteria

- a. No sustained arc shall occur.
- b. Testing shall demonstrate that the observed primary arcs do not produce any type of damage to the solar array or to the cells.

### 5.5.1.6 Erosion of materials

- a. The test sequence, test definitions and requirements for the tests for erosion of material shall be agreed between the supplier and the customer and stated in the SCD-PVA.

### 5.5.1.7 EMC

- a. The test sequence, test definitions and requirements related to the EMC of the PVA shall be agreed between the supplier and the customer and given in the SCD-PVA.

## 5.5.2 Acceptance tests for qualification coupons

### 5.5.2.1 Purpose

The acceptance tests are performed to check the workmanship of the supplier.

### 5.5.2.2 Applicability

Acceptance test are applicable to completed and qualified hardware, except if the acceptance tests are part of the qualification process.

### 5.5.2.3 Deliverables

- a. The deliverable documentation shall be agreed with the customer.

NOTE The acceptance is dependant on this test and the documentation delivered.

### 5.5.2.4 Process

- a. All acceptance tests shall be in conformance with clause 5.2.  
b. All results of the acceptance test shall be reported in the data documentation package (DDP).

NOTE For the DDP, see clause 5.7 and Annex G.

- c. The standard sequence of acceptance tests for PVA shall be as presented in Table 5-2.  
d. The bake-out test shall be performed as part of the coupon acceptance test sequence only in the cases where the bake-out is included in the manufacturing process or in the acceptance test of the flight panels.

**Table 5-2: Acceptance test plan**

Sequence number	Test
Add-on mass (5.5.3.1)	0
Full visual inspection (5.5.3.2)	1, 6, 10
Electrical health check (5.5.3.3)	2, 7, 11
Capacitance (5.5.3.5)	3, 13
Electrical performance (5.5.3.4)	4, 8,12
Bake-out (5.5.3.6)	5
Thermal cycling (5.5.3.7)	9
NOTE: See 5.5.2.4d	

## 5.5.3 Definition of tests and checks

### 5.5.3.1 Add-on mass measurement

- a. The mass of the panel shall be measured after the coupon is equipped with the PVA parts and the harness, and the add-on mass deduced.  
b. The add-on mass of both the PVA and the harness shall be in conformance with the value given the SCD-PVA.

### 5.5.3.2 Full visual inspection

#### 5.5.3.2.1 Purpose

The full VI is performed to detect imperfections in the complete hardware.

#### 5.5.3.2.2 Process

- a. A full visual inspection shall be performed against the inspection requirements stated in clauses 5.5.3.2.4 to 5.5.3.2.21, as follows:
  1. Visually examine each component for workmanship, identification and finish.
  2. Examine the deliverable items for conformance to general assembly drawings, with respect to critical dimensional parameters.

NOTE The inspection methods to be used include:

- electroluminescence
- infrared inspection;
- inspection with the naked eye;
- inspection using microscopes;
- any equivalent methods.

- b. Training records of the personnel performing the visual inspection shall be made available to the customer under request.

#### 5.5.3.2.3 General criteria

- a. The PVA supplier shall define the inspection criteria for the PVA components, to be agreed by the customer, and included in the SCD-PVA.

#### 5.5.3.2.4 Visual inspection of dimensions, stay-out zones, and stand-offs

- a. The dimensions shall conform to the qualification coupon assembly drawing.
- b. Cells and components shall not enter the stay-out zones indicated on the qualification coupon assembly drawing.
- c. The stand-off distance of cells and components shall conform to the qualification coupon assembly drawing.

#### 5.5.3.2.5 Visual inspection of the substrate

- a. Substrates shall be inspected for any damage due to coupon assembly, handling and testing.
- b. The insulator material shall show no evidence of delamination.

NOTE The insulator material is usually kapton.

- c. The integrity of the substrate shall not deviate from the coupon assembly drawing.

#### 5.5.3.2.6 Visual inspection of the coverglass

- a. All the coverglass shall be inspected for defects in conformance with requirements 5.5.3.2.6b to 5.5.3.2.6e.

- b. No more than 5 % of the total number of coverglasses shall exhibit any of the following defects on the coupon, due to assembly, handling and acceptance:
  - 1. For 100 % covered cells, or cells where the unprotected solar cell surface is covered with the coverglass adhesive up to a maximum of 5 % of the cell area, chips and nicks in the coverglass with the characteristics specified in clause 6.4.3.1.4.
  - 2. Cracks on the coverglass, except if they meet the following conditions:
    - (a) no visible separation (in conformance with clause 6.4.3.1.4);
    - (b) no more than three per cover;
    - (c) meeting cracks if they are separated by more than 2 mm at the non-meeting end.
- c. Any defect in conformance with requirement 5.5.3.2.6b, raised after acceptance shall be reported and traced throughout the qualification sequence.
- d. Covers with dirty and contaminated surfaces shall be cleaned.
- e. Coverglasses with any of the following defects shall be rejected at the end of acceptance:
  - 1. Coverglasses installed upside down as indicated by improper location of the coating orientation mark in conformance with clause 8.3.3.
  - 2. Coverglass which is not flush with or overhanging all four cell edges.
  - 3. Coverglasses with dirty and contaminated surface if they cannot be cleaned.
  - 4. Loose coverglasses.
  - 5. Corner chip exceeding the limits specified in requirement 5.5.3.2.6b.1.
  - 6. Edge chips exceeding the limits specified in clause 6.4.3.1.4.
  - 7. Coverglasses with intersecting cracks exceeding the limits specified clause 6.4.3.1.4.

#### 5.5.3.2.7 Visual inspection of the coverglass adhesive

- a. After coverglass or solar cell repair, there shall be no delamination or discoloration in the adhesive, except in the area opposite rear welds, where discoloration may be present.
- b. After coverglass or solar cell repair, adhesive voids along the cover edge shall not exceed 0,6 mm in depth.
- c. After coverglass or solar cell repair,, the maximum total projected area of additional bubbles shall not exceed 0,2 % of cell area, discounting:
  - 1. bubbles less than 0,02 mm<sup>2</sup> in the projected area, and

2. bubbles, discolorations and voids located at less than 2 mm from the interconnector edges.

#### 5.5.3.2.8 Visual inspection of the solar cells

- a. No more than 2 % of the total quantity of solar cells or one cell, whichever is larger, per coupon shall exhibit any of the following defects:
  1. More than the number of cracks per cell specified in the SCD-PVA.
  2. Cracks crossing more than the number of different gridlines specified in the SCD-PVA.
  3. Corner chips and edge chips greater than those specified in clause 6.4.3.1.4.
- b. Any imperfections listed in requirements 5.5.3.2.8a.1 to 5.5.3.2.8a.3, raised after acceptance shall be reported and traced throughout the qualification sequence.
- c. Solar cells with any of the following defects shall be rejected at the end of acceptance:
  1. Cracks crossing more gridlines than defined in requirement 5.5.3.2.8a.2.

NOTE Multiple crossing of the same gridline can be present.

2. More cracks than defined in requirement 5.5.3.2.8a.1 on a single cell.
3. Cracks between the cell edges parallel to the gridlines and the outermost edges of the interconnectors.
4. Corner chip exceeding the limits specified in clause 6.4.3.1.4.
5. Edge chips exceeding the limits specified in clause 6.4.3.1.4.

#### 5.5.3.2.9 Visual inspection of the solar cell bypass diodes

- a. Cracks in the body of the diode, causing separation of the material, shall not be present.
- b. Tarnishing of the diode body or attachment serpentines may be present.

#### 5.5.3.2.10 Visual inspection of the interconnectors

- a. No more than 2 % of the total number of interconnectors and no more than one interconnector per cell shall exhibit any of the following defects at the end of acceptance testing:
  1. Deformation.
  2. Solder or adhesive blocking, bridging, plugging or otherwise impeding the flexure of the stress relief loop.
  3. Foreign matter or contamination on the interconnector or within the interconnector weld or solder joint or within the stress relief loop.

- b. Any imperfections listed in requirements 5.5.3.2.10a.1 to 5.5.3.2.10a.3, raised after acceptance shall be reported and traced throughout the qualification sequence.
- c. None of the interconnectors shall exhibit lifting tears, breaks or cracks.
- d. Interconnectors may be tarnished.

#### 5.5.3.2.11 Visual inspection of the bus bars

- a. None of the bus bars shall exhibit any of the following defects at the end of acceptance testing:
  - 1. Solder or adhesive blocking, bridging, plugging or otherwise impede the flexure of stress relief loops between solar cell strings.
  - 2. Foreign matter, or contamination on the interconnector, within the interconnector weld or solder joint, or within the stress relief loop.
  - 3. Tears, breaks or cracks.
- b. Any defect listed in requirements 5.5.3.2.11a.1 to 5.5.3.2.11a.3, raised after acceptance shall be reported and traced throughout the qualification sequence.
- c. Tarnishing may be present on the end terminations.

#### 5.5.3.2.12 Visual inspection of the wiring

- a. None of the wiring shall exhibit any of the following defects at the end of acceptance testing:
  - 1. Sharp bends, sharp twists, sharp buckles or creases in the wire.
  - 2. Delamination or looseness of the wire attachment.
  - 3. Chafing or abrasion of the wire insulation.
  - 4. Cracks, breaks or nicks in the wire insulation or conductor.
  - 5. Exposed shields on shielded wires.
- b. Any defects listed in requirements 5.5.3.2.12a.1 to 5.5.3.2.12a.5, raised after acceptance shall be reported and traced throughout the qualification sequence.

#### 5.5.3.2.13 Visual inspection of the soldering

- a. Soldering of wires at string terminations and terminals shall be in conformance with a standard agreed with the customer

NOTE For soldering, see for instance ECSS-Q-ST-70-08.

#### 5.5.3.2.14 Visual inspection of the welding

- a. Welding of wires at string terminations and terminals shall be in conformance with the SCD-PVA.

#### 5.5.3.2.15 Visual inspection of the crimping

- a. Crimping of wires shall be in conformance with a standard agreed with the customer.



NOTE For crimping, see for instance ECSS-Q-ST-70-26.

#### 5.5.3.2.16 Visual inspection of the attachment materials

- a. Attachments based on bonding techniques shall be fully cured and not exhibit any tackiness.

#### 5.5.3.2.17 Visual inspection of the feed-throughs

- a. Feed-throughs shall be firmly bonded.
- b. Feed-throughs shall conform to the locations specified on the top assembly drawing.

#### 5.5.3.2.18 Visual inspection of the marking

- a. All identification markings specified by the customer shall be firmly adhered to the locations identified on the assembly drawing.
- b. Identification markings shall be clearly legible.

#### 5.5.3.2.19 Visual inspection of the hardware

- a. Terminal board locations shall conform to the qualification coupon assembly drawing.
- b. Stand-off of all components shall conform to the qualification coupon assembly drawing.
- c. For mounted components (temperature sensor, resistors and diodes), the following shall be performed:
  1. Verify the status of the following items:
    - (a) fixation on the substrate;
    - (b) body aspect and absence of cracks;
    - (c) connections;
    - (d) shrinkage tube.
  2. Ensure that conformal coating of the components,:
    - (a) consist of a uniform layer of the specified adhesive, and
    - (b) encapsulate the components.
- d. For the connectors, the status of the following items shall be verified:
  1. fixing on the substrate;
  2. absence of cracks;
  3. connections;
  4. shrinkage tube.

#### 5.5.3.2.20 Visual inspection of the bonding integrity

- a. 100 % of the solar cells shall be inspected for bond integrity.
- b. Any loose cells shall not be used unless an engineering disposition, specifying that it can be used, is issued.

#### 5.5.3.2.21 Visual inspection of the cleanliness

- a. When visually examined with the unaided eye, the coupon shall appear clean.
- b. There shall be no loose material on the coupon.

### 5.5.3.3 Electrical health check

#### 5.5.3.3.1 Purpose

All tests specified in this clause are part of the electrical health check. The purpose of the electrical health check together with the electrical performance measurement is to detect faults in the electrical functions of the electrically active parts of the PVA.

#### 5.5.3.3.2 Electrical continuity check

- a. All electrical circuits of the PVA shall be checked to ensure electrical continuity, and the test conditions shall be stated in the SCD-PVA.

#### 5.5.3.3.3 Insulation resistance

- a. An insulation test shall be performed at the voltage stated in the SCD-PVA to measure the insulation between the following:
  1. the structure ground or substrate (+) and the solar cell circuits (-) including soldering and wiring;
  2. adjacent solar cell strings if not parallel connected;
  3. the thermal sensor (+) and the substrate (-);
  4. the thermal sensor (+) and cell strings (-);
  5. the cover glass network (-) to cell strings (+) if the coverglass network is grounded;
  6. the cover glass network (+) to cell strings (-) if the coverglass network is grounded.

- b. The insulation shall be in conformance with that stated in the SCD-PVA.

#### 5.5.3.3.4 Grounding resistance test

- a. All resistance at grounding spots shall be measured.
- b. The grounding resistance shall be the value stated in the SCD-PVA.

#### 5.5.3.3.5 Bleed resistor test

- a. The resistance of the bleed resistor shall be measured.
- b. The resistance shall be the value stated in the SCD-PVA.

#### 5.5.3.3.6 Blocking diode test

- a. The reverse current of the blocking diode shall be measured at a voltage equal to the predicted maximum  $V_{oc}$  during the mission.
- b. The reverse current measured shall be negligible with respect to the string current (usually less than 5 mA).

- c. The forward voltage drop of the blocking diode shall be measured with the string at maximum  $I_{sc}$  current.
- d. Test conditions and requirements shall be stated in the SCD-PVA.

#### 5.5.3.3.7 Shunt diode test

- a. When all the cells are protected by shunt diodes, the forward voltage of shunt diodes shall be measured by reverse mode measurement of the interconnected string at the maximum operating current and the measured voltage shall be equal  $\pm 1\%$  to the sum of the individual diode forward voltages at the maximum current.
- b. When all the cells are protected by shunt diodes, the supplier shall provide the test method and precautions to be taken.
- c. When all the cells are protected by shunt diodes, during the test, the temperature increase of the shunt diode shall be uniform and shall not exceed the value stated in the SCD-PVA.

NOTE If the measured voltage is outside the sum of the individual diode forward voltages at the maximum current  $\pm 1\%$ , techniques such as thermographic photo recordings may be used to locate the failed shunt diodes.

#### 5.5.3.3.8 Thermal sensor test

- a. The thermal sensor resistance shall be measured at room temperature.
- b. The thermal sensor resistance shall be the value stated in the SCD PVA.

#### 5.5.3.3.9 Resistance measurement

- a. The resistance of the harness shall be measured at the interface connector by measuring the redundant coupon wiring in series (i.e. positive end to positive end and negative end to negative end).
- b. Test conditions and requirements shall be described in the SCD-PVA.

### 5.5.3.4 Electrical performance measurement

#### 5.5.3.4.1 Purpose

The power output is measured in order to be able to detect any degradation before and after testing.

#### 5.5.3.4.2 Process

- a. The electrical power performance at the string level shall be measured at a reference temperature of  $25\text{ }^{\circ}\text{C}$  at the interface connector.
- b. The performance measurement shall be made under 1 S.C. (AM0).

NOTE The characteristics of the Sun simulator are given in clause 10.

- c. The results shall be in conformance with those stated in the SCD-PVA.

- d. The inaccuracies in current, voltage and power shall be specified in the SCD-PVA and include:
  1. spectral mismatch;
  2. uniformity of the test area;
  3. dynamic electrical effects of the test item

NOTE Example: capacitance.

  4. inaccuracies of the temperature sensors.
- e. Calibration shall be done with an agreed primary standard reference and secondary working standard (SWS) in conformance with clause 10.
- f. Pre-test and post-test measurements shall be made with the same test set-up.

### **5.5.3.5 Capacitance test**

#### **5.5.3.5.1 Purpose**

The purpose of the test is to measure the capacitance of the PVA by measuring the string capacitance in order to characterise the electrical dynamical behaviour of the PVA in interaction with the power regulator. Different types of power regulator require different measurement techniques. The methods described in clause 5.5.3.5.2 are applicable only to PVA interacting with a sequential switching shunt regulator.

#### **5.5.3.5.2 Process**

- a. One of the following methods shall be followed for capacitance measurement:
  1. frequency domain single junction solar cell capacitance measurement as described in clause 11.1,

NOTE No method available for multi-junction measurement at the time being.
  2. Time domain capacitance measurement as described in clause 11.2.
- b. The method for measuring the capacitance shall be stated in the SCD-PVA.
- c. The capacitance shall be measured at room temperature and averaged operational temperature.
- d. The measurement at averaged operational temperature can be replaced by measurement of the SCA capacitance at operational temperature.

### **5.5.3.6 Bake-out**

- a. Measures to prevent outgassing, to be taken before exposure to vacuum conditions, shall be agreed with the customer.
- b. If a vacuum bake-out at the panel level is specified in the solar array specification, a vacuum bake-out shall be performed on the PVA before thermal cycling at coupon level.
- c. Temperature and test conditions shall be defined in SCD-PVA.

### 5.5.3.7 Thermal cycling acceptance test

#### 5.5.3.7.1 Purpose

The thermal cycle acceptance tests assess the reliability of the PVA under stress and verify the workmanship of the supplier. In this way infant mortality stresses are identified and these parts can be replaced.

#### 5.5.3.7.2 General

- a. Thermal vacuum cycling should be used.
- b. If gaseous cycling tests are used, the supplier shall demonstrate the equivalence of the test method.
- c. The temperature extremes of the thermal cycling shall be extended or a dedicated structural test shall be performed in cases where analysis demonstrates that the structural loading results in a greater stress than the thermal cycling.

#### 5.5.3.7.3 Process

- a. The panels shall be exposed to the number of thermal cycles for acceptance as stated in the SCD-PVA.
- b. The number of cycles specified in requirement 5.5.3.7.3a shall be between 4 and 10.
- c. The temperature profile shall be the worst-case nominal temperature profile with a 5 °C margin.
- d. During thermal cycling, the electrical insulation shall be measured.
- e. During thermal cycling, the continuity shall be measured at least during the last cycle.
- f. Continuity and insulation shall not be measured simultaneously.
- g. Acceptance criteria shall be:
  1. A maximum increment of  $I_{OP}$ , and a minimum isolation, as stated in the SCD-PVA.
  2. The existence of electrical continuity (no open circuit).
  3. At the end of the test, less than a 2 % increase in cracked cells or one cracked cell, whichever is higher, not cumulative with the results of the bake-out test and which can have an impact on the electrical performance of the string.

#### 5.5.3.8 Reflectance

- a. The reflectance of the solar cell surface shall be measured before and after the humidity test to determine the possible degradation of the coverglass coatings.
- b. The reflectance shall be measured over a range from 280 nm to 2 500 nm.
- c. The reflectance shall not change during testing more than as stated in the SCD-PVA.

### 5.5.3.9 X-Ray

- a. X-ray photographs shall be taken of all busbars, wire collection strips and diode boards on the qualification coupons.
- b. The acceptance criteria shall be stated in the SCD-PVA.

NOTE Defects that cannot be detected by means of visual inspections (e.g. internal structural deformations or alterations in busbars and wire connections) can be traced by X-ray photographs.

### 5.5.3.10 Substrate integrity

#### 5.5.3.10.1 Process

- a. The structural integrity of the substrate shall be inspected after thermal cycling.
- b. A non-destructive test method should be used for the inspection specified in requirement 5.5.3.10.1a.
- c. If requirement 5.5.3.10.1b cannot be satisfied, a destructive test shall be applied.
- d. The test method shall be described in the SCD-PVA.

#### 5.5.3.10.2 Pass-fail criteria

- a. The pass-fail criteria shall be those stated in the SCD-PVA.

### 5.5.3.11 Vacuum thermal cycling

#### 5.5.3.11.1 Purpose

Vacuum thermal cycling is performed in order to verify the integrity of components, assemblies and interfaces in a vacuum environment.

#### 5.5.3.11.2 Process

- a. The components to be checked for electrical continuity shall be identified in the SCD-PVA.
- b. The qualification coupon shall be exposed to vacuum thermal cycling.
- c. The qualification coupon shall be exposed to 10 vacuum thermal cycles
- d. The pressure shall be lower than  $2 \times 10^{-3}$  Pa.
- e. The temperature profile shall be the worst-case nominal temperature profile with a 10 °C margin.
- f. During vacuum thermal cycling the electrical continuity of the components identified in requirement 5.5.3.11.2a, including if present (at least) strings, diodes, thermal sensors and resistors, shall be recorded.
- g. The insulation resistance of the strings against the substrate shall be recorded for a minimum of 2 cycles, without performing electrical continuity.

#### 5.5.3.11.3 Pass-fail criteria

- a. The qualification coupon electrical performance and insulation resistance shall not degrade more than as stated in the SCD-PVA.
- b. No open circuit conditions shall be recorded during continuity testing.
- c. There shall be less than a 2 % increase in cracked cells or one cracked cell, whichever is higher, not cumulative with the results of the fatigue thermal cycling test, and which can have an impact on the electrical performance of the string.

## 5.6 Failure definition

### 5.6.1 Failure criteria

- a. The following shall constitute PVA failures:
  1. Coupons that fail during subgroup tests for which the pass-fail criteria are inherent in the test method.
  2. Coupons failing to conform to the requirements of the visual inspection as listed in the SCD-PVA.
  3. Coupons that fail to conform to stress requirements as listed in the SCD-PVA.
  4. Coupons that, when subjected to electrical performance measurements after qualification tests in conformance with the SCD-PVA, fail one or more of the stated limits, measurement accuracy included.

### 5.6.2 Failed qualification coupons

- a. A coupon shall be considered as failed if it exhibits one or more of the failure modes detailed in requirement 5.6.1a.
- b. Failure analysis of these coupons shall be performed by the supplier and the results provided to the customer, as part of an NRB documentation.

NOTE For NRB, see ECSS-Q-ST-10-09.

## 5.7 Data documentation

- a. The supplier shall provide a data documentation package (DDP) in conformance with Annex G for the qualification approval records for each coupon.

## 5.8 Delivery

- a. All deliverable hardware specified in the order shall be delivered together with documentation in conformance with clause 5.7.

- b. One set of documents shall be sent to the customer.

## **5.9 Packaging, packing, handling and storage**

For packaging, dispatching, handling and storage of components see ESA-PSS-01-202.



# 6

## Solar cell assemblies

---

### 6.1 General

#### 6.1.1 Testing

- a. Qualification testing of solar cell assemblies (SCAs) shall comprises acceptance and qualification tests.
- b. Testing of previously qualified SCAs shall comprises acceptance tests and delta qualification tests in conformance with requirement 6.4.1f.4.

#### 6.1.2 Conditions and methods of test

- a. The conditions and methods of testing shall conform to the SCA source control drawing (SCD-SCA).

NOTE The SCA specification consists of two parts, the generic specification (this Standard) and the SCD-SCA. For the preparation of the SCD-SCA, refer to Annex B.

- b. The SCD-SCA shall be prepared by the supplier in conformance with Annex B, and provided to the customer for reviewing and agreement.
- c. Any deviation from the required in-process, acceptance and qualification test shall be justified in the documentation package.
- d. Deviations from this Standard applicable to the SCD-SCA shall:
  1. be agreed between the customer and the supplier;
  2. not affect the reliability and performances of the SCAs;
  3. only be those specified in requirement 6.1.2c.

#### 6.1.3 Deliverable components

- a. Delivered solar cell assemblies shall be produced and inspected in conformance with the requirements of the process identification document (PID) defined in clause 6.2, and
- b. Delivered solar cell assemblies shall have completed all tests and inspections included in the SCD-SCA.

### 6.1.4 Identification and traceability

- a. All delivered solar cell assemblies shall be permanently marked with a code to enable traceability of the cells at the level stated in the PID.

NOTE For the PID, see clause 6.2.

## 6.2 Production control (process identification document)

- a. A process identification document (PID) for the SCA to be qualified shall be prepared by the supplier in conformance with Annex F.
- b. The supplier shall do the following:
  1. maintain configuration control of all documents;
  2. keep the issues of the documents effective at the date of acceptance by the customer;
  3. provide the PID to the customer for review;
  4. submit to the customer for review and approval any modifications or changes to documents in the PID with any quality and reliability implications.

## 6.3 Acceptance tests

### 6.3.1 General

- a. Acceptance tests shall be performed on the following:
  1. components for delivery;
  2. components used for qualification.
- b. Acceptance tests shall consist of the following:
  1. visual inspection (100 % of the SCAs), in conformance with clause 6.4.3.1.
  2. dimension and weight inspection (1 % of the SCAs), in conformance with clause 6.4.3.2.
  3. electrical performance measurement (100 % of the SCAs), in conformance with clause 6.3.3.
  4. diode characterization (100 % of the SCAs), in conformance with clause 9.4.5.2.
- c. The data documentation corresponding to the tests referred to in requirement 6.3.1b shall be delivered together with the delivered SCAs and the qualification test lot as part of the DDP.

NOTE For the DDP, see clause 6.6.

### **6.3.2 Test methods and conditions**

- a. The test methods and conditions specified in clause 6.4.3 shall be applied.

### **6.3.3 Electrical performance acceptance test (EPA)**

#### **6.3.3.1 Purpose**

The purpose of the EPA test is to measure the electrical performance of the SCA for current class grading.

#### **6.3.3.2 Process**

- a. The electrical current of SCA under 1 S.C. (AM0) shall be measured at operational voltage ( $I_{op}$ ) at a solar cell temperature of 25 °C or operating temperature.
- b. The predicted operational voltage ( $V_{op}$ ) shall be defined in the SCD-SCA.
- c. The accuracy of  $I_{op}$  and  $V_{op}$  shall be provided to the customer.
- d. During measurement, the SCAs shall be kept at a constant temperature.
- e. Continuous or pulsed light source calibrated in conformance with clause 10 shall be used to verify the requirements given in clause 6.3.3.3 for electrical characterization.

#### **6.3.3.3 Pass-fail criteria**

- a. The pass fail criteria shall be indicated in the SCD-SCA.

## **6.4 Qualification tests**

### **6.4.1 General**

- a. All SCA procurement lots shall be qualified.
- b. Qualification shall be granted by the customer.
- c. The qualification plan shall consist of the tests specified in Table 6-1.
- d. The following requirements shall apply to the qualification plan:
  1. Ensure that welding parameters, the material and dimensions of the interconnectors, cementing conditions, adhesive and coverglass for the following activities in Table 6-1, are in conformance with the production process for solar panels that applies to the supplier of the SCA:
    - (a) Front interconnect welding
    - (b) Coverglass bonding

- (c) Rear interconnect welding
- 2. Perform UV test (step 16 in Table 6-1) in subgroup B on a minimum of 6 SCAs.

**Table 6-1: Qualification test plan for SCA**

Test	Symbol	Method	Bare cells (40 samples)		Solar cell assemblies (30 , 40 or 50 samples)			
			A (20)	E (20)	B (20)	C (10) / (20) (see 6.4.3.11.2.e)	D (10)	F(20)
Front Interconnect Welding	FIW		4	4				
Coverglass Bonding	CB			5				
Rear Interconnect Welding	RIW			6				
Visual inspection	VI	6.4.3.1	1,5,9,13	1,7,11,15	1,17,20	1,10 / 1,10,16	1,6,8,12	1,5
Dimension and weight	DW	6.4.3.2			2	2 / 2	2	2
Electrical performance	EP	6.4.3.3	2,6,10	2,8,12	4,7,10,14,18	3,6,11,15 / 3,6,11,17,21	3,9,13	3,6
Temperature coefficients & Diode Temperature Behaviour	TC TB	6.4.3.4 9.6.14			12	13 / 13,19		
Spectral response	SR	6.4.3.5				7,16 / 7,21		
Thermo-optical data	TO	6.4.3.6			15,19	17 / 22		
Thermal cycling	CY	6.4.3.7	8	10				
Humidity and temperature	HT	6.4.3.8					5	
Coating adherence	CA	6.4.3.9					7	
Interconnector adherence	IA	6.4.3.10	12	14				
Electron irradiation	EI	6.4.3.11				8 / 8,14	11	
Photon irradiation and temperature annealing	PH	6.4.3.12			9	9 / 9,15		
Surface conductivity	SC	6.4.3.13					4,10,14	
Diode characterization	DC	9.6.15	3,7,11	3,9,13	5,8,11,21	4,12/4,12,18		
Cell reverse bias test	RB	6.4.3.14			13	5,14 / 5,20		
Ultraviolet exposure	UV	6.4.3.15			16			
Capacitance	CT	6.4.3.16			6			
Flatness	FT	6.4.3.17			3			
Life Test	LT	6.4.3.18						4
<p>NOTE 1 The numbers in the subgroup columns indicate the sequence in which the tests are performed; e.g. for subgroup A, the 1st test is VI, the 2nd test EP, the 3rd is DC, and so on.</p> <p>NOTE 2 The reason for dividing the test samples into subgroups is to generally test for the following:</p> <ul style="list-style-type: none"> <li>- Subgroup A: front interconnector adherence;</li> <li>- Subgroup E: rear interconnector adherence;</li> <li>- Subgroup B: BOL performance data and ultraviolet exposure;</li> <li>- Subgroup C: EOL performance data;</li> <li>- Subgroup D: surface conductivity and humidity on SCA (for coverglasses with conductive coating only)</li> <li>- Subgroup F: Life test</li> </ul> <p>NOTE 3 The number of test samples are indicated between brackets e.g. A (20)</p> <p>NOTE 4 For additional requirements, refer to requirement 6.4.1d.</p> <p>NOTE 5 Perform UV test (step 16) in subgroup B on a minimum of 6 SCAs</p>								

- e. The supplier shall provide details of the outcome of the qualification programme to the customer.
- f. For a procurement lot of a previously qualified SCA, the qualification tests need not be repeated if the following conditions are satisfied:
  - 1. No changes are made to the design, function or electrical or mechanical parameters of the solar cell assembly.
  - 2. The same source control drawing is applicable.
  - 3. No changes are made to the PID.
  - 4. Delta qualification tests are performed to cover the requirements imposed by the new application.
- g. For 6.4.1f.4, the new requirements shall be included in a new version of the SCD-SCA.

## **6.4.2 Qualification**

### **6.4.2.1 Production and test schedule**

- a. Before starting production of the qualification lot, the manufacturer shall compile a production test schedule, showing by date and duration, production and test activities, including all major processing operations and key stages in the production and testing.
- b. A production flow chart, process schedules and inspection procedures shall be provided.

### **6.4.2.2 Qualification test samples**

- a. The solar cell assemblies for qualification testing shall conform to the PID.
- b. The supplier shall provide access to the customer to monitor the manufacture of the test samples in conformance with a procedure agreed with the customer.
- c. The test samples shall be chosen statistically and at random from the first manufacturing lots of the procurement lot.

NOTE For sampling, see ISO 2859.

- d. Facilities shall be available to safely store the qualification lot (included failed samples) for a minimum of 6 years (equivalent to five years in storage and one year in orbit).

### **6.4.2.3 Qualification testing**

- a. Qualification testing shall proceed as given in Table 6-1.
- b. The total quantity of test samples shall be a minimum of 80 or 90 SCAs depending on previous testing, in conformance with requirement 6.4.3.11.2e.

- c. The qualification tests shall be divided into subgroups of tests, and the samples assigned to a subgroup shall be subjected to the tests in that subgroup in the sequence specified.
- d. A failure in any subgroup shall constitute a failure in the qualification.

NOTE For a definition of failure see clause 6.5.

### **6.4.3 Test methods, conditions and measurements**

#### **6.4.3.1 Visual inspection (VI)**

##### 6.4.3.1.1 Applicability

The requirements on visually observable defects defined in this clause apply to granting qualification approval to high quality solar cell assemblies.

##### 6.4.3.1.2 Test process

- a. The SCAs shall be inspected with an equipment with a resolution which is 5 times higher than the minimum allowed defect size to verify requirements on the following:
  - 1. defects on cell;
  - 2. coverglass;
  - 3. adhesive;
  - 4. contacts;
  - 5. interconnector.

##### 6.4.3.1.3 Deviations

- a. Any deviation from the visual inspection requirements on defects shall:
  - 1. not affect performance or reliability,
  - 2. be agreed with the customer, and
  - 3. be justified.

##### 6.4.3.1.4 Solar cell defects

- a. The location and maximum dimensions of edge chips, corner chips and surface nicks shall be in conformance with Figure 6-1 and Table 6-2.
- b. The cumulative area of all defects of the types specified in requirement 6.4.3.1.4a shall not exceed 5 % of the total solar cell area.
- c. Defects of the types specified in requirement 6.4.3.1.4a occurring in the contact weld area shall be prevented.
- d. Cracks or fingerprints shall not be present on solar cells.
- e. The total area of anti-reflection coating voids shall not exceed 3 % of the total active area of the cell.

#### 6.4.3.1.5 Coverglass defects

- a. The coverglasses shall be inspected to ensure 100 % coverage of the bare surface of the cells.
- b. Chips and nicks may be present on coverglasses if the bare surface of the solar cell is 100 % covered.
- c. Covers with dirty and contaminated surfaces shall be rejected.
- d. The total area of ARC and conductive coating voids, including evaporation jig marks, shall not exceed 3 % of the area of the coverglass.
- e. The coverglass shall not contain bubbles having a projected area larger than 0,02 mm<sup>2</sup>.
- f. Coverglasses shall be rejected if they contain cracks with any one of the following characteristics:
  1. there is a visible separation between cracks;
  2. there are more than three per cover;
  3. meeting cracks are separated by more than 2 mm at the non-meeting end.

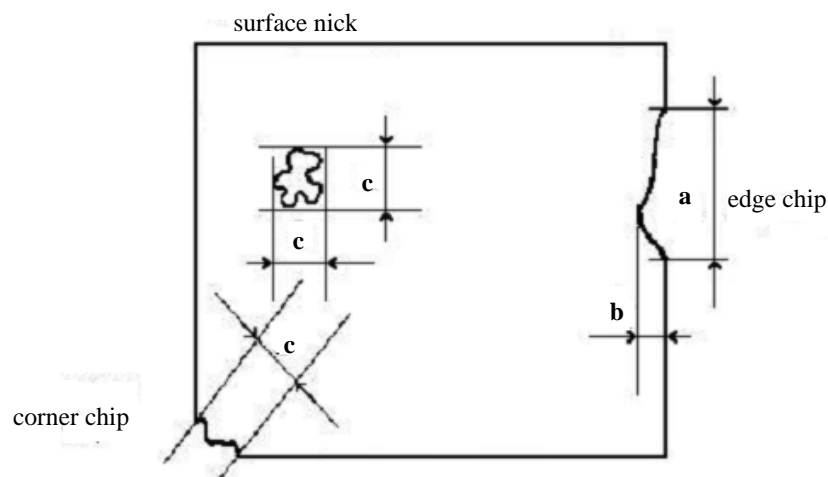

Figure 6-1: Definition of cell defects

Table 6-2: Maximum dimensions of corner chips, edge chips and surface nicks

Cell area (cm <sup>2</sup> )	Dimensions of defects (mm)		
	a	b	c
4	4	0,7	1,5
8	6	0,8	2
12	8	0,9	2,5
25	10	1	4
32	12	1,1	5



#### 6.4.3.1.6 Coverglass adhesive defects

- a. There shall be no delamination or discolouration in the adhesive, except in the area opposite rear welds, where discolouration may be present.
- b. Adhesive voids along the cover edge shall not exceed 0,6 mm in depth.
- c. The maximum total projected area of additional bubbles shall not exceed 0,2 % of the cell area, discounting the following:
  1. bubbles less than 0,02 mm<sup>2</sup> in the projected area, and
  2. bubbles, discolourations and voids located less than 2 mm from the interconnector edges.

#### 6.4.3.1.7 Front contact defects

- a. Interruptions and delaminations in the front contact shall be prevented.
- b. Over-coating (coating exceeding the area of the contact) along one side of each welding pad shall not exceed 0,1 mm.
- c. The maximum total length of missing grids, short grids or non-continuous grids shall not exceed the total length of 3 grids.

#### 6.4.3.1.8 Rear contact defects

- a. For the rear side contact, outside the welding area, the following conditions shall be met:
  1. Drops and spatter do not exceed 0,1 mm in diameter and 0,05 mm in height.
  2. The maximum deep of edge delaminations do not exceed 0,75 mm.
  3. Other defects do not exceed a total of 2 % of the cell contact area.
  4. The area of worm shaped bulges is 3 % of the total cell contact area, or less.
  5. The maximum length of the hypotenuse of the triangular area of visible semiconductor at the corners of the solar cell (c) is in conformance with Table 6-2.
- b. In the interconnector weld area, clause 7.5.1.5.2 shall apply.

#### 6.4.3.1.9 Interconnector defects

- a. Breaking, tearing or deformation of the interconnector shall be prevented.

#### 6.4.3.2 Dimensions and weight (DW)

- a. The overall lateral dimensions of the SCA and the interconnector position shall be inspected for compliance with the dimensions and tolerances stated in the SCD-SCA.
- b. The lateral dimensions of the coverglasses shall be such as to ensure 100 % coverage of the bare surface of the cells.

- c. The weight of the SCA shall be verified by determining the average weight per qualification lot to ensure that this conforms to the value stated in the SCD-SCA.

### 6.4.3.3 Electrical performance (EP)

#### 6.4.3.3.1 Purpose

The purpose of the EP test is to assess the corresponding electrical parameters of the SCA and to provide data for the design of the solar generator.

#### 6.4.3.3.2 Process

- a. The electrical current of SCA under 1 S.C. (AM0) shall be measured and recorded digitally at least at 50 points, at a solar cell temperature of 25 °C +/- 0,5 °C or operating temperature.
- b. The electrical parameters measured or processed from requirement 6.4.3.3.2a and identified in Figure 6-2 shall be
  1. derived from the full curve, and
  2. delivered to the customer together with:
    - (a) their average and standard deviation, and
    - (b) digital data of the full curve.

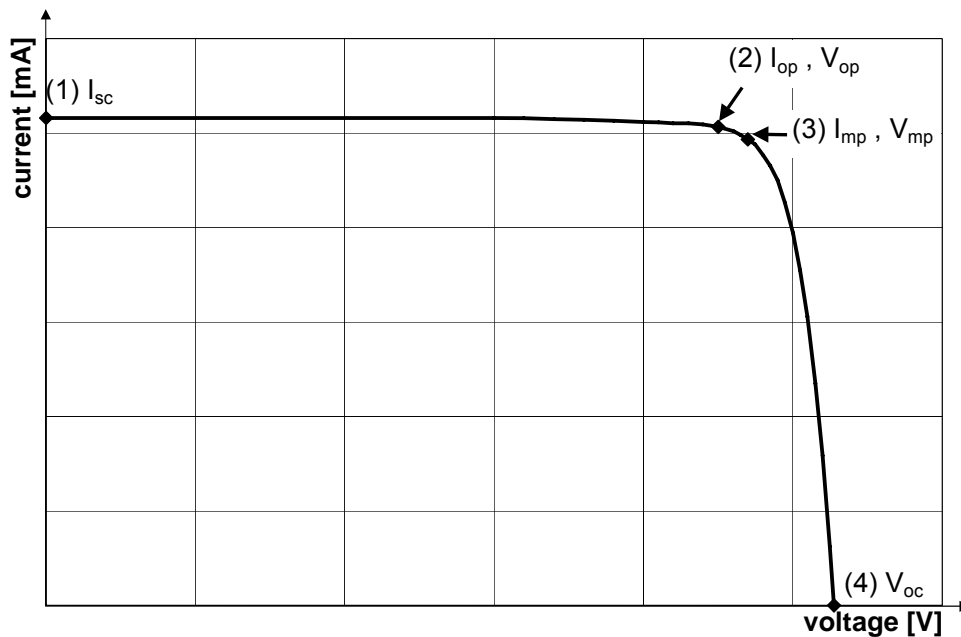

NOTE:  $I_{op}$  and  $V_{op}$  are equal to the  $I_{test}$  and  $V_{test}$  of the SCD SCA

**Figure 6-2: Test points for electrical performance measurement**

- c. The accuracy of the SCA measured parameters ( $I_{sc}$ ,  $I_{test}$ ,  $V_{test}$ ,  $V_{oc}$  and  $P_{max}$ ) shall be provided to the customer.
- d. During measurement, the SCAs shall be kept at a constant temperature +/- 0,5 °C.

- e. A continuous or pulsed light source calibrated in conformance with clause 10 shall be used to verify the requirements given in 6.4.3.3.2c for electrical characterization during both qualification and acceptance testing.

#### 6.4.3.3.3 Pass-fail criteria

- a. The minimum current requirement for solar cell assemblies before and after electron radiation testing shall be stated in the SCD-SCA.
- b. The maximum deviation in current measured at  $V_{\text{test}}$  before and after CY for subgroups A and E (in conformance with Table 6-1) shall be 2 % for each individual cell.
- c. After qualification tests, the maximum degradation of electrical performance shall be in conformance with requirements 6.4.3.3.3a and 6.4.3.3.3b.

#### 6.4.3.4 Temperature coefficients (TC)

- a. Temperature coefficient measurement at SCA level need not be performed if already performed during qualification at bare cell level.
- b. Temperature coefficients of all samples in subgroup B and half of the samples of subgroup C shall be measured.
- c. The test described in clause 6.4.3.3 shall be repeated at six equidistant solar cell temperatures between two temperature extremes  $t_1$  and  $t_2$ , calculated as follows, and stated in the SCD-SCA:
  - $t_1$  = highest operating temperature (without margins) predicted for the mission + 25 °C.
  - $t_2$  = lowest operating temperature (without margins) predicted for the mission (including eclipse exit) - 25 °C.
- d. Data for all electrical performance parameters at the different solar cell temperatures shall be provided.
- e. The temperature coefficients of short-circuit current, open circuit voltage, voltage at maximum power and current at maximum power shall be derived by least-square curve fitting.
- f. The coefficient of determination for the indicated electrical parameters obtained from the curve fit shall be included.

#### 6.4.3.5 Spectral response (SR)

##### 6.4.3.5.1 Purpose

Spectral response data is used for the verification of the Sun simulator (see clauses 10.1.1 and 10.1.2) for performance measurement error calculation, and for the characterization of the spectral response spread of production SCAs.

##### 6.4.3.5.2 Process

- a. Spectral response shall be measured in subgroup C on half of the samples before irradiation, by comparing the short-circuit current of the test SCAs

- against the output of a spectral standard of known relative spectral response under monochromatic irradiation.
- b. Subgroup C samples where spectral response has been measured shall be later irradiated to the highest dose and subsequently submitted to spectral response test
  - c. The monochromatic irradiation shall be generated by one of the following methods:
    1. With the aid of narrow-band interference filters, having the following characteristics:
      - (a) for silicon solar cells, at least, at 14 discrete wavelength intervals between 0,3  $\mu\text{m}$  and 1,1  $\mu\text{m}$ ;
      - (b) for single-junction GaAs solar cells at least, at 14 discrete wavelength intervals between 0,3  $\mu\text{m}$  and 1,1  $\mu\text{m}$  and at least 3 narrow band interference filters in the range 0,75  $\mu\text{m}$  to 1,1  $\mu\text{m}$ .
      - (c) for multi-junction GaAs solar cells, the number of narrow band interference filters and their wavelength are stated in the SCD-SCA.
    2. By means of a high-intensity monochromator for continuous recording between 0,3  $\mu\text{m}$  and at least 1,8  $\mu\text{m}$ .
  - d. The irradiation intensity at all wavelengths shall be such as to ensure that the measurement is made in the region where the cell response short-circuit current versus irradiance is linear.
  - e. For multi-junction solar cells, it shall be ensured that the measurements are performed on the current limiting subcell, and that it is working close to short-circuit conditions.

### **6.4.3.6 Thermo-optical data (TO)**

#### **6.4.3.6.1 Overview**

Thermo-optical data is used for computation of the solar panel operational temperature.

#### **6.4.3.6.2 Process**

- a. For Subgroup B step 15 (in conformance with Table 6-1), the solar absorptance and the hemispherical emittance shall be measured according to ECSS-Q-ST-70-09 on at least two samples.
- b. For subgroup B step 18 and for subgroup C, the solar absorptance and the hemispherical emittance should be measured according to ECSS-Q-ST-70-09.
- c. For subgroup B step 18 and for subgroup C, the portable absorptance and the normal emittance should be measured according to ECSS-Q-ST-70-09, provided that the same measurements have been performed in all samples of subgroup B step 15.

#### 6.4.3.6.3 Pass-fail criteria

- a. Pass-fail criteria for the SCAs thermo-optical properties shall be as stated in the SCD-SCA.

### 6.4.3.7 Thermal cycling (CY)

#### 6.4.3.7.1 Purpose

The purpose of this test is to assess the reliability of test samples under a thermal stress equivalent to the number of eclipses that occur during one year in orbit for LEO missions, and 1000 thermal cycles for GEO missions or the complete lifetime cycling for interplanetary or other mission types.

#### 6.4.3.7.2 Process

- a. The number of cycles and the extreme temperatures shall be as stated in the SCD-SCA.

### 6.4.3.8 Humidity and temperature (HT)

#### 6.4.3.8.1 Purpose

This test is an accelerated shelf-life test to monitor the coverglass conductive coating in a humid atmosphere.

#### 6.4.3.8.2 Process

- a. All SCAs in subgroup D shall be placed in a chamber at ambient pressure.
- b. The chamber temperature shall then be increased to 60 °C minimum.
- c. Relative humidity shall be higher than 90 %.
- d. The duration of the test shall be 30 days.
- e. In the case of solar cells with aluminium content window layers, the HT test shall be extended to simulate on-ground expected duration and humidity and temperature conditions.
- f. High-purity water in conformance with ASTM D1193-99, Type I, shall be used.
- g. Water condensation on the surface of the SCAs shall be prevented.
- h. If there are requirements on specific environmental conditions (such as chemical vapours), they shall be stated in the SCD-SCA.

### 6.4.3.9 Coating adherence (CA)

#### 6.4.3.9.1 Purpose

This test is performed to verify the durability of the coverglass conductive coating.

#### 6.4.3.9.2 Process

- a. All SCAs of subgroup D shall be subjected to a coating adherence test on the coverglass SCA face.
- b. Test conditions shall be established according to a standard which is mutually agreed with the customer.

NOTE Example of standards that can be used for the test conditions of the coating adherence test are ISO 9211-4 and ECSS-Q-ST-70-13.

- c. The adhesive tape used for this test shall be clear in colour with an adhesive strength on steel of at least 0,28 N/mm width.

NOTE Example of standard that can be used to measure to the adhesive strength is EN 1939.

- d. Any visible delamination of parts of the coverglass coating shall not exceed the limits specified in requirement 6.4.3.1.4e.

### 6.4.3.10 Interconnector adherence (IA)

#### 6.4.3.10.1 Purpose

The purpose of this test is to monitor the bond strength of interconnectors under mechanical and thermal stress and to verify the electrical stability after interconnector welding.

#### 6.4.3.10.2 Process

- a. A gradually increasing pull force shall be applied to the interconnector tabs at a pull speed stated in the SCD-SCA.
- b. The ultimate pull strength of each tab shall be as stated in the SCD-SCA.
- c. The pull direction shall:
  1. be either 0°, 45° or 90°;
  2. be as stated in the SCD-SCA.

### 6.4.3.11 Electron irradiation (EI)

#### 6.4.3.11.1 Purpose

EI test is an accelerated life test to check the solar cell performance degradation under electron particle irradiation.

#### 6.4.3.11.2 Process

- a. The SCAs shall be subjected to 1 MeV electron irradiation.

NOTE ISO 23038 outlines a methodology to perform this test.

- b. The flux density and energy shall be uniform over the cell area to within  $\pm 10\%$ .

- c. During irradiation, the cells shall be protected from oxidation using either a vacuum (below  $10^{-3}$  Pa) or a dry atmosphere of nitrogen or argon at a temperature of  $(20 \pm 10)$  °C.
- d. The nominal rate shall be lower than or equal to  $5 \times 10^{11} \text{ e}^- \text{ cm}^{-2} \text{ s}^{-1}$ .
- e. The irradiation shall be performed as follows:
  1. State the expected dose for the envisaged application,  $\Phi_p$ , the SCD-SCA.
  2. If the BSC was qualified according to the same specific mission requirements of the SCA (Subgroup C2 of the BSC qualification programme, in conformance with Table 7-2):
    - (a) the minimum dose is  $\Phi_p$ ;
    - (b) perform tests on Subgroup C (in conformance with Table 6-1) on 10 mid-grade cells only.
  3. If qualified BSC was submitted for general characterization (Subgroup C1 of the BSC qualification programme, in conformance with Table 7-2):
    - (a) Perform subgroup C (in conformance with Table 6-1) on 20 cells, divided in two batches of 10 samples constituted as follows: 2 high-grade, 6 mid-grade and 2 low-grade SCAs;;
    - (b) Irradiate one batch of 10 samples 2 times at  $\Phi_p/2$ , as a minimum;
    - (c) Irradiate the second batch times at  $\Phi_p$ , as a minimum.

NOTE This results in data for 10 samples at  $\Phi_p/2$ , at  $\Phi_p \times 2$ , and data for 20 samples at  $\Phi_p$ .
- f. The sequence of tests in Table 6-1 shall be arranged so SCAs of subgroup D are irradiated at  $\Phi_p$ .
- g. After combined electron and photon irradiation, the SCAs shall conform to the requirements stated in the SCD-SCA.
- h. Electron irradiation at a dose corresponding to the dose at transfer orbit shall be added when specified by the mission requirements; this dose shall be included in the SCD-SCA.

### 6.4.3.12 Photon irradiation and temperature annealing (PH)

#### 6.4.3.12.1 Purpose

This test is to verify the stability of SCA performance under the equivalent light and temperature of 1 S.C. (AM0).

#### 6.4.3.12.2 Process

- a. During the test, SCAs in subgroups B and C shall be subjected to the following:
  1. irradiated with 1 S.C. (AM0) for 48 h;
  2. be kept at  $(25 \pm 5)$  °C;

3. arranged in an open circuit condition.
- b. Multi-junction solar cells shall be subsequently temperature annealed for 24 h at 60 °C.
- c. After the tests the SCAs shall be kept at temperatures below 50 °C until they are electrically measured.

### **6.4.3.13 Surface conductivity (SC)**

#### **6.4.3.13.1 Purpose**

This test is to verify the average conductivity of conductive coverglasses across the total surface.

#### **6.4.3.13.2 Process**

- a. The surface conductivity of coverglasses for SCAs of subgroup D shall be measured.
- b. The measurement specified in requirement 6.4.3.13.2a shall be performed between the cover contact dots or by the method described in the SCD-SCA.

#### **6.4.3.13.3 Pass-fail criteria**

- a. The average conductivity across the total surface shall conform to the requirements stated in the SCD-SCA.

### **6.4.3.14 Solar Cell Reverse Bias Test (RB)**

#### **6.4.3.14.1 Purpose**

The purpose of solar cell reverse bias test is to check for performance degradation of the SCA due to reverse bias.

#### **6.4.3.14.2 Process**

- a. For SCAs without a protection diode or with a protection diode electrically isolated from the cell, the reverse I/V characteristics of the SCA under illumination of 1 S.C. (AM0) with a limiting power supply (to avoid destructive breakdown) shall be measured.
- b. For SCAs with a protection diode electrically connected to the cell, solar cell reverse bias test shall not be performed.

#### **6.4.3.14.3 Pass-fail criteria**

- a. The parameters of reverse I/V characteristics measurement shall be as stated in the SCD-SCA concerning temperature, hold time, current limitation, maximum reverse bias (voltage).

### **6.4.3.15 Ultraviolet exposure test (UV)**

#### **6.4.3.15.1 Purpose**

This test is an accelerated life test with the purpose of checking the stability of the solar cells assembly under ultraviolet light exposure.



#### 6.4.3.15.2 Process

- a. The integrated intensity of the photons shall be measured with a Sun-blind photo-diode.
- b. For photons with a wavelength between 200 nm to 400 nm, the integrated intensity at the end of test shall be as follows:
  1. equal to (1000 - 1500) Sun-hours or 1 % of the mission life, whichever is the longer period;
  2. have a UV irradiation acceleration factor of less than 10 Suns.
- c. Spectral Irradiance for UV light sources shall be performed in conformance with ECSS-Q-ST-70-06.
- d. The test shall be performed in a vacuum (i.e. pressure less than  $10^{-3}$  Pa).
- e. The temperature of the SCAs shall be the nominal operational temperature  $\pm 10$  °C (in conformance with SCD-SCA).
- f. The short circuit current resulting from the applied UV light source of at least one of the SCA's shall be continuously monitored and recorded.
- g. Measure the current output of the solar cells at identical bias conditions, using a stable light source, not necessarily AMO representative, during the execution of the UV exposure at regular intervals (at least 3 - including the begin and the end of the UV exposure).
- h. Control samples shall be included in the UV chamber in order to identify potential contaminations occurring during the test.

#### 6.4.3.15.3 Pass Fail Criteria

- a. The electrical performance of the SCAs shall not degrade more than 70 % of the UV loss factor used for the EOL power analysis.
- b. The UV loss factor shall be specified in the SCD-SCA.
- c. The current output measured at the intervals specified in requirement 6.4.3.15.2g shall demonstrate an exponential decay.

### 6.4.3.16 Capacitance test (CT)

#### 6.4.3.16.1 Purpose

The purpose of this test is to gather data for the panel level by extrapolating the data obtained on the capacitance of the SCA.

#### 6.4.3.16.2 Process

- a. One of the following methods shall be followed for capacitance measurement:
  1. Frequency domain single junction solar cell capacitance measurement as described in clause 11.1.  

NOTE No method available for multi-junction measurement at the time being.
  2. Time domain capacitance measurement as described in clause 11.2.

- b. The method for measuring the capacitance shall be stated in the SCD-SCA.
- c. The capacitance shall be measured at SCA level in conformance with the method referred in requirement 6.4.3.16.2b at the temperature range stated in the SCD-SCA.

#### **6.4.3.17 Flatness test (FT)**

##### **6.4.3.17.1 Purpose**

The purpose of this test is to determine the flatness of the SCA.

##### **6.4.3.17.2 Process**

- a. The flatness shall be determined by measuring the maximum deflection of the SCA measured on an optically flat surface.

##### **6.4.3.17.3 Pass/fail criteria**

- a. The deflection of the SCA shall be lower than the deflection value,  $d$  in Figure 8-6, stated on the SCD-SCA.

#### **6.4.3.18 Life test (LT)**

##### **6.4.3.18.1 Purpose**

The purpose of this test is to determine the stability of the solar cell assembly under worst case operation conditions for long duration.

##### **6.4.3.18.2 Process**

- a. One of the following two methods shall be proposed and described by the supplier as life test:
  - 1. Determine the activation energy by measuring the time to failure at several temperatures.
  - 2. Demonstrate by assuming an activation energy of 0,7 eV that the stability is not affected within the duration of the mission.
- b. The test environment shall at least comprise vacuum conditions,, illumination and cell operation at a working point.

## **6.5 Failure definition**

### **6.5.1 Failure criteria**

- a. The following shall constitute SCA failures:
  - 1. SCAs which fail during subgroup tests for which the pass-fail criteria are inherent in the test method.
  - 2. SCAs failing to conform to the requirements of the visual inspection specified in clause 6.4.3.1.

3. Components whose marking fails to conform to the requirements of clause 6.1.4.
4. SCAs that, when subjected to electrical performance measurements after qualification tests in conformance with the SCD-SCA, fail one or more of the specified limits, measurement accuracy included.

### **6.5.2 Failed SCAs**

- a. An SCA shall be considered as failed if it exhibits one or more of the failure modes detailed in clause 6.5.1.
- b. Failed SCAs shall be identified as such and be included in the delivery.
- c. Failure analysis of these SCAs shall be performed by the supplier and the results provided to the customer, as part of an NRB documentation.

NOTE For NRB, see ECSS-Q-ST-10-09.

## **6.6 Data documentation**

- a. The supplier shall provide a data documentation package in conformance with Annex G for the qualification approval records and for each SCA delivery lot.

## **6.7 Delivery**

- a. All deliverable hardware specified in the order shall be delivered together with documentation in conformance with the requirements specified in clause 6.6.
- b. One set of documents shall be sent to the customer.

## **6.8 Packing, dispatching, handling and storage**

### **6.8.1 Overview**

For packaging, dispatching, handling and storage of components see ESA-PSS-01-202.

### **6.8.2 ESD Sensitivity**

- a. If a SCA is sensitive to ESD according to clause 5.2 of ESCC 23800 Issue 1 then it shall be handled and stored according to ESCC 24900 Issue 2 clause 10.

# 7

## Bare solar cells

---

### 7.1 Testing, deliverable components and marking

#### 7.1.1 Testing

##### 7.1.1.1 Tests for qualification and procurement

- a. Testing for the qualification of bare solar cells (BSCs) shall comprise acceptance and qualification testing.
- b. Testing for the procurement of qualified solar cells shall comprise acceptance tests and delta qualification tests in conformance with clause 7.4.1e.4.

##### 7.1.1.2 Conditions and methods of tests

- a. The conditions and methods of testing shall conform to the bare solar cell source control drawing (SCD-BSC).

NOTE The bare solar cell specification consists of two parts, the generic specification (this Standard) and the SCD-BSC. The SCD-BSC contains the technical specification for a cell type relevant to acceptance testing, as well as for the qualification testing. For the preparation of the SCD-BSC for bare solar cells, refer to Annex C.

- b. The SCD-BSC shall be prepared by the supplier in conformance with Annex C and provided to the customer for reviewing and agreement.
- c. Any deviation from in-process, acceptance and qualification test procedures shall be justified in the SCD-BSC.
- d. Deviations from this Standard applicable to the SCD-BSC shall:
  1. be agreed between the customer and the supplier;
  2. include alternative requirements equivalent to those of this Standard;
  3. not affect the reliability and performances of the BSCs;
  4. only be those specified in requirement 7.1.1.2c.

### **7.1.1.3 Responsibility of supplier for the performance of tests and inspections**

- a. The supplier shall ensure that the tests and inspections are performed.
- b. The tests and inspections specified in requirement 7.1.1.3a shall be performed at the manufacturer's plant or at a facility approved by the customer.

NOTE For test house requirements, see ECSS-Q-ST-20-07.

### **7.1.1.4 Preliminary characterization**

- a. Before starting a qualification, the manufacturer shall verify the BOL and EOL solar cell characteristics on a representative production lot.
- b. The approach followed for the RDC determination shall be defined and the availability of a consistent data set demonstrated.
- c. The manufacturer shall propose a sampling method and procedure for customer approval.

NOTE No pass fails are foreseen during the execution of the sampling

### **7.1.2 Deliverable components**

- a. Delivered solar cells shall be processed and inspected in conformance with the requirements of the process identification document (PID) defined in requirement 7.2:
- b. Delivered solar cells shall have completed all tests and inspections specified herein in conformance with the SCD-BSC.

### **7.1.3 Marking**

- a. All delivered solar cells shall be permanently marked with a code to enable traceability of the cells at the level specified in the PID

## **7.2 Production control (process identification document)**

- a. The process identification document (PID) for the bare solar cell (BSC) to be qualified shall be prepared by the supplier in conformance with Annex F.
- b. The supplier shall do the following:
  - 1. maintain configuration control of all documents;
  - 2. keep the issues of the documents effective at the date of acceptance by the customer;
  - 3. provide the PID to the customer for review;

4. submit to the customer for review and approval any modifications or changes to documents in the PID with any quality and reliability implications.

## 7.3 Acceptance tests

### 7.3.1 General

- a. Acceptance tests shall be performed on the following:
  1. components for delivery;
  2. components used for qualification.
- b. Acceptance tests shall consist on the tests specified in Table 7-1.
- c. The generic specification to be used for each of the tests specified in Table 7-1 shall be agreed with the customer.
- d. The sample size shall be in conformance with Table 7-1, but it may be modified depending on the specific project requirements as stated in SCD-BSC.
- e. The data documentation corresponding to the tests referred to in requirement 7.3.1b shall be delivered together with the delivered cells and the qualification test lot.
- f. For cells with integral diode the acceptance tests described in Table 9-1 shall be performed.

**Table 7-1: Acceptance test matrix**

Test	Symbol	Verification method	Sample Size
Visual inspection	VI	7.5.1	100 %
Dimension and weight	DW	7.5.2	1 %
Flatness	FT	7.5.19	2 cells
Surface Finish	SF	7.5.11	2 cells
Contact thickness	CT	7.5.10	1 %
Solar Cell Reverse Bias test	RB	7.5.16	100 %
Electrical performance	EPA	7.3.2.2	100 %
Hemispherical reflectance <sup>(a)</sup>	HR	7.5.6.2	1 %
Humidity and temperature	HT	7.5.7.2	1 %
Coating adherence	CA	7.5.8	1 %
Humidity and temperature, and pull	HT/PT	7.5.7.2 and 7.5.12	1 %
Coverglass gain - loss		7.5.6.3	1 %
<sup>(a)</sup> only for BSR solar cells.			

## 7.3.2 Test methods and conditions

### 7.3.2.1 Test other than electrical performance

- a. Except for electrical performance, the test methods and conditions for acceptance shall conform to clause 7.5.

### 7.3.2.2 Electrical performance

#### 7.3.2.2.1 Purpose

The purpose of the EPA test is to measure the electrical parameters of the BSC.

#### 7.3.2.2.2 Process

- a. The electrical current of BSC under 1 S.C. (AM0) shall be measured at short circuit ( $I_{sc}$ ) and at specified test voltage, ( $I_{test}$ ) at a solar cell temperature of  $25\text{ °C} \pm 0,5\text{ °C}$  or operating temperature.
- b. The specified test voltage ( $V_{test}$ ) shall be defined in the SCD-BSC.
- c. The open circuit voltage of the BSC under 1 S.C. shall be measured at a solar cell temperature of  $25\text{ °C} \pm 0,5\text{ °C}$  or operating temperature.
- d. The accuracy of the BSC measured parameters ( $I_{sc}$ ,  $V_{oc}$ ,  $I_{test}$  and  $V_{test}$ ) shall be provided to the customer.
- e. During measurement, the BSCs shall be kept at a constant temperature  $\pm 0,5\text{ °C}$ .
- f. Continuous or pulsed light source calibrated in conformance with clause 10 shall be used to verify the requirements given in 7.3.2.2.3 for electrical characterization.

#### 7.3.2.2.3 Pass-Fail Criteria

- a. The pass fail criteria shall be indicated in the SCD-BSC.

#### 7.3.2.2.4 Electrical grading in acceptance tests

- a. The BSCs tested in conformance with clause 7.3.2.2.2 and accepted shall be graded for  $I_{test}$  performance
- b. The grading intervals (in mA) shall be stated in the SCD-BSC.

## 7.3.3 Documentation

- a. Documentation on acceptance tests shall conform to clause 7.7.

## 7.4 Qualification tests

### 7.4.1 General

- a. Qualification shall be granted by the customer.
- b. The qualification plan shall consist of the tests specified in Table 7-2.

- c. During the qualification, all cells in subgroup A shall be equipped with front and rear interconnectors (in conformance with clause 7.5.10.2) after step 6 (in conformance with Table 7-2).
- d. The supplier shall provide details of the outcome of the qualification programme to the customer.



**Table 7-2: Qualification test plan for bare solar cells**

Test	Symbol	Method	Bare cells (108)					
			A (20)	B (20)	C1 (24)	C2 (24)	O (20)	P (24)
Interconnect Welding	IW		7					
Visual inspection	VI	7.5.1	1,8,10	1,14	1,7,15	1,7,13,21	1,6,10,14	1,7,13
Dimensions and weight	DW	7.5.2	2	2	2	2	2	2
Electrical performance	EP	7.5.3	3	5,8,13	3,9,13	3,9,15,19	3,7,11	3,9
Temperature coefficients & Diode Temperature Behaviour	TC	7.5.4		10	11	11,17		11
	TB	9.6.14						
Spectral response	SR	7.5.5			5,14	5,20		5,12
Optical properties	OP	7.5.6		11				
Humidity and temperature 1	HT1	7.5.7.1					5	
Humidity and temperature 2	HT2	7.5.7.2	9					
Coating adherence	CA	7.5.8					13	
Contact uniformity	CU	7.5.9	5					
Surface Finish	SF	7.5.11	6					
Pull	PT	7.5.12	11					
Electron Irradiation	EI	7.5.13			6	6,12		
Proton irradiation	PI	7.5.14						6
Photon irradiation	PH	7.5.15		7	8	8,14		8
Diode characterisation	DC	9.6.15	4	6,9	4,10	4,10,16	4,8,12	4,10
Solar Cell reverse bias test	RB	7.5.16		12	12	18		
Thermal cycling	CY	7.5.17					9	
Active-passive interface	IF	7.5.18		3				
Flatness	FT	7.5.19		4				

NOTE 1 The numbers in the subgroup columns indicate the sequence in which the tests are performed; e.g. for subgroup O, the 1st test is VI, the 2nd test DW, the 3rd is EP, the 4th is DC and so on.

NOTE 2 The reason for dividing the test samples into subgroups is to generally test for the following:

- Subgroup A: contact adherence (front and rear side)
- Subgroup B: BOL performance
- Subgroup C1: Electron irradiation (general)
- Subgroup C2: Electron irradiation (mission specific) [optional]
- Subgroup O: Extended storage simulation
- Subgroup P: Proton irradiation

NOTE 3 For additional requirements, refer to 7.4.1c.

- e. For a procurement lot of previously qualified solar cells, the qualification tests need not to be repeated if the following conditions are satisfied:
  1. No changes are made to the design, function or electrical or mechanical parameters of the bare solar cell.

2. The same source control drawing is applicable.
  3. No changes are made to the PID.
  4. Delta qualification tests are performed to cover the requirements imposed by the new application.
- f. The new requirements referred to in 7.4.1e.4 shall be included in a new version of the SCD-BSC.

## 7.4.2 Qualification

### 7.4.2.1 Production and test schedule

- a. Before starting production of the qualification lot, the manufacturer shall compile a production test schedule showing by date and duration of the production and test activities, including all major processing operations and key stages in the production and testing.
- b. A production flow chart, process schedules and inspection procedures shall be provided.

### 7.4.2.2 Qualification test samples

- a. The solar cells for qualification testing shall conform to the PID.
- b. The test samples shall be chosen statistically and at random from the qualification lot

NOTE For sampling see ISO 2859.

- c. The qualification lot shall be a production lot of at least 400 cells or the number of cells to be integrated on the solar array, whichever is lower.
- d. The total number of samples shall be divided into three equal groups, referred to as high-grade, mid-grade and low-grade according to their current at operating voltage.
- e. Facilities shall be available to safely store the qualification lot including failed samples for a minimum of 6 years (equivalent to five years in storage and one year in orbit).

### 7.4.2.3 Qualification testing

- a. Qualification testing shall proceed as given in Table 7-2.
- b. The total quantity of test samples shall be a minimum of 108 (either subgroup C1 or C2) bare solar cells.
- c. The qualification tests shall be divided into subgroups of tests, and the samples assigned to a subgroup subjected to the tests in that subgroup in the sequence specified.
- d. More than one failure in any subgroup, or more than two failures in total, shall constitute a failure in the qualification.

NOTE For a definition of failure see clause 7.6.

## 7.5 Test methods, conditions and measurements

### 7.5.1 Visual inspection (VI)

#### 7.5.1.1 Applicability

The requirements on visually observable defects defined in this clause apply to granting qualification approval to a high quality bare solar cell.

#### 7.5.1.2 Test process

- a. Solar cells shall be inspected with an equipment with a resolution which is 5 times higher than the minimum allowed defect size to verify the requirements for defects on solar cell and contacts.

#### 7.5.1.3 Deviations

- a. Any deviation from the visual inspection requirements on defects specified in clauses 7.5.1.4 and 7.5.1.5 shall:
  1. not affect performance or reliability,
  2. be agreed with the customer, and
  3. be justified.

#### 7.5.1.4 Solar cell defects

##### 7.5.1.4.1 Edge chips, corner chips and surface nicks

- a. The location and maximum dimensions for allowable defects related to edge chips, corner chips and surface nicks shall be in conformance with Figure 7-1 and Table 7-3.
- b. The cumulative area of all edge chips, corner chips and surface nicks shall not exceed 5 % of the total cell area.
- c. Edge chips, corner chips and surface nicks shall not be present in the contact weld area.

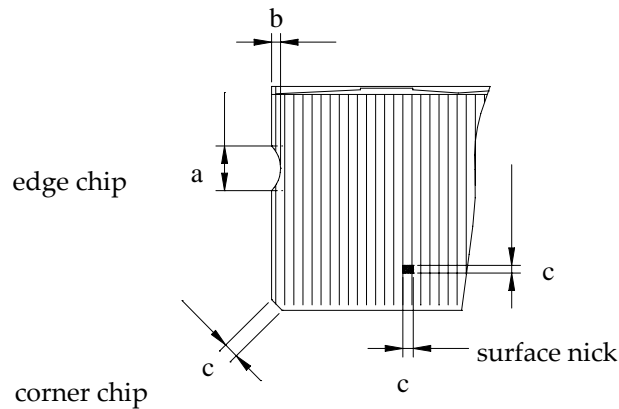

**Figure 7-1: Definition of bare solar cell defects**

**Table 7-3: Maximum dimensions of corner chips, edge chips and surface nicks**

Cell area (cm <sup>2</sup> )	Dimensions of defects (mm)		
	a	b	c
4	4	0,7	1,5
8	6	0,8	2
12	8	0,9	2,5
25	10	1	4
32	12	1,1	5

#### 7.5.1.4.2 AR coating

- For acceptance and qualification, the maximum value of the total uncoated area, and the value of spatter and voids shall be 3 %.
- The AR coating may contain discolourations.

#### 7.5.1.4.3 Cracks and fingerprints

- Cracks and fingerprints shall not be present.

### 7.5.1.5 Solar cell contact area defects

#### 7.5.1.5.1 General

- The solar cell contact area shall be free of digs, scratches, and probe prints, unless metallization is still present.
- Peeling, blistering and delamination of contacts shall not be present.

#### 7.5.1.5.2 Front and rear side contact welding area

- The maximum dimension of voids or bubbles shall be 0,25 mm in diameter.
- The maximum dimension of drops and spatter shall be 0,1 mm in diameter and 0,03 mm in height.

- c. Over-coating (coating exceeding the area of the contact on the frontside only) along one side of each pad shall not exceed 0,1 mm.
- d. Digs or depressions deeper than 0,025 mm shall not be present.
- e. The cumulative area of voids, bubbles, drops and spatter shall not exceed 2 % of the total welding area.

#### 7.5.1.5.3 Front bus bar and grids

- a. There shall be no interruptions in the front bus bar.
- b. The maximum total length of missing grids, short grids or non-continuous grids shall not exceed a total length of 3 grids.

#### 7.5.1.5.4 Rear side contact outside the welding area

- a. Drops and spatter shall not exceed 0,1 mm in diameter and 0,05 mm in height.
- b. The cumulative area of voids, bubbles and drops shall not exceed 2 % of the total area.
- c. Edge delaminations shall not be deeper than 0,75 mm.
- d. The maximum area of worm shaped bulges shall be 3 % of total cell contact area.
- e. The maximum length of the hypotenuse of the triangular area of visible semiconductor at the corners, shall be included in the SCD-BSC.

### 7.5.2 Dimensions and weight (DW)

- a. The overall lateral dimensions of the cell (including thickness), contact dimensions and interconnector position shall conform to the requirements stated in the SCD-BSC.
- b. The weight of the solar cell shall be verified by determination of the average weight per qualification lot or weight per contacts vacuum evaporation batch (sample base).

### 7.5.3 Electrical performance (EP)

#### 7.5.3.1 Purpose

The purpose of the EP test is to assess the corresponding electrical parameters of the solar cells and to provide data for the design of the solar generator.

#### 7.5.3.2 Process

- a. The electrical current of solar cells under 1 S.C. (AM0) shall be measured and recorded digitally, at least at 50 points, at a solar cell temperature of 25 °C or operating temperature.
- b. The electrical parameters measured or processed from requirement 7.5.3.2a and identified in Figure 6-2 shall

1. be derived from the full curve, and
2. delivered to the customer together with:
  - (a) their average and standard deviation values, and
  - (b) digital data of the full curves.
- c. The accuracy of the bare solar cell measured parameters ( $I_{sc}$ ,  $V_{oc}$  and  $P_{max}$ ) shall be provided to the customer.
- d. During measurement, the cells shall be kept at a constant temperature ( $\pm 0,5$  °C).
- e. A continuous or pulsed light source calibrated in conformance with clause 10 shall be used to verify the requirements given in the SCD-BSC for electrical characterization.
- f. There shall be a maximum of 3 % deviation in the current at the test voltage  $V_t$ , from the measurements before test, after the humidity and thermal cycling test in subgroup O.

#### **7.5.4 Temperature coefficients (TC)**

- a. Temperature coefficients of all samples in subgroup B and on a minimum of 12 samples from each of subgroups C1, C2 and P shall be measured.
- b. The electrical performance test described in clause 7.5.3 shall be repeated, as a minimum, as follows:
  1. In the temperature range between 25 °C and 80 °C with intermediate temperatures at 40 °C and 60 °C, (subgroups B, C1 and P).
  2. For mission specific qualification (subgroup B, C2 and P) at six equidistant solar cell temperatures between two temperature extremes  $t_1$  and  $t_2$  calculated as follows:
    - $t_1$  = highest operating temperature (without margins) predicted for the mission + 25 °C
    - $t_2$  = lowest operating temperature (without margins) predicted for the mission - 25 °C
- c. Data for all electrical performance parameters at the different solar cell temperatures shall be provided.
- d. The temperature coefficients of short-circuit current, open circuit voltage, voltage at maximum power and maximum power shall be derived by least-square curve fitting.
- e. The coefficient of determination for the electrical parameters specified in requirement 7.5.4d, obtained from the curve fit specified in requirement 7.5.4d shall be included.

## 7.5.5 Spectral response (SR)

### 7.5.5.1 Purpose

Spectral response data is used for the verification of the sun simulator (see clauses 10.1.1 and 10.1.2) for performance measurement error calculation, for the characterization of the spectral response spread of production cells, for EOL degradation evaluation and for current matching investigation in multi-junction solar cells.

### 7.5.5.2 Process

- a. Spectral response shall be measured on half of the samples of subgroup C1, C2 and P, by comparing the short-circuit current of the test cells against the output of a spectral standard of known relative spectral response under monochromatic irradiation.
- b. The monochromatic irradiation shall be generated by one of the following methods:
  1. The irradiation shall be generated with the aid of narrow-band interference filters, having the following characteristic:
    - (a) for silicon solar cells, at least, at 14 discrete wavelength intervals between 0,3  $\mu\text{m}$  and 1,1  $\mu\text{m}$ ;
    - (b) for single-junction GaAs solar cells at least, at 14 discrete wavelength intervals between 0,3  $\mu\text{m}$  and 1,1  $\mu\text{m}$  and at least 3 narrow band interference filters in the range 0,75  $\mu\text{m}$  to 1,1  $\mu\text{m}$ .
    - (c) for multi-junction GaAs solar cells, the number of narrow band interference filters and their wavelength are stated in the SCD-BSC.
  2. By means of a high intensity monochromator for continuous recording between 0,3  $\mu\text{m}$  and at least 1,8  $\mu\text{m}$ .
- c. The irradiation intensity at all wavelengths shall be such as to ensure that the measurement is made in the region where the cell response short-circuit current versus irradiance is linear.
- d. For multi-junction solar cells, it shall be ensured that the measurements are performed on the current limiting subcell, and that it is working close to short-circuit conditions.

## 7.5.6 Optical properties (OP)

### 7.5.6.1 Overview

Hemispherical reflectance is used for the definition of acceptance criteria for silicon BSR solar cells only. Coverglass gain loss, is measured to provide input for the performance of the SCA. Solar absorptance of the cell is measured to provide data on the operational temperature of the SCA.

### **7.5.6.2 Hemispherical reflectance (HR)**

- a. Hemispherical reflectance shall be measured in the wavelength region from 250 nm to 2500 nm.
- b. The reflectance value for the acceptance of silicon BSR solar cells at 1,5  $\mu\text{m}$  shall be stated in the SCD-BSC.

### **7.5.6.3 Coverglass gain-loss (GL)**

- a. For single junction solar cells, the coverglass gain-loss stated in the SCD-BSC shall be determined by using n-Amyl alcohol in order to simulate the optical properties of the adhesive.
- b. For multi-junction solar cells, the agent to be used to simulate the optical properties of the adhesive shall be stated in the SCD-BSC.
- c. The coverglass as stated in the SCD-BSC shall be used.
- d. The solar cells shall be submitted to an electrical performance test before and after applying the coverglass, as defined in requirements 7.5.6.3a to 7.5.6.3c, according to clause 7.5.3 under the following test conditions:
  1. at an illumination of 1 S.C. (AM0);
  2. a temperature, as stated in the SCD-BSC.
- e. The pass-fail criteria shall be stated in the SCD-BSC.

### **7.5.6.4 Solar absorptance ( $a_s$ )**

- a. The solar absorptance shall be measured according to ECSS-Q-ST-70-09.

## **7.5.7 Humidity and temperature (HT)**

### **7.5.7.1 HT1 for qualification testing (subgroup O)**

#### **7.5.7.1.1 Purpose**

This test is an accelerated shelf-life test to monitor the stability of contacts, anti-reflection coatings and integrated diode in a humid atmosphere.

#### **7.5.7.1.2 Process**

- a. All cells in subgroup O shall be placed in a chamber at ambient pressure.
- b. The chamber temperature shall then be increased to 60 °C minimum.
- c. Relative humidity shall be higher than 90 %.
- d. The duration of the test shall be 30 days.
- e. In the case of solar cells with Aluminium content window layers, this test shall be extended to simulate on-ground expected duration, and humidity and temperature conditions.
- f. High-purity water in conformance with ASTM D1193-99, Type I, shall be used.
- g. Water condensation on the surface of the cells shall be prevented.



- h. If there are requirements on specific environmental conditions, such as chemical vapours, they shall be stated in the SCD-BSC.

### **7.5.7.2 HT2 for qualification (subgroup A) and acceptance testing**

#### **7.5.7.2.1 Purpose**

This test is to verify the adherence of the contacts to the solar cell and diode, if available.

#### **7.5.7.2.2 Process**

- a. All cells shall be placed in a chamber at ambient pressure.
- b. The chamber temperature shall then be increased to 95 °C minimum.
- c. Relative humidity shall be higher than 90 %.
- d. The duration of the test shall be 24 h.
- e. High-purity water in accordance with ASTM D1193-99, Type I, shall be used.
- f. Water condensation on the surface of the cells shall be prevented.
- g. If there are requirements on specific environmental conditions, such as chemical vapours, they shall be stated in the SCD-BSC.

## **7.5.8 Coating adherence (CA)**

### **7.5.8.1 Purpose**

This test is performed to verify the durability of the anti-reflection coating, the contacts of cell and integrated diode.

### **7.5.8.2 Process**

- a. The test samples shall be subjected to a coating adherence test on both sample faces.
- b. Test method shall be established according to a standard which is mutually agreed with the customer.

NOTE For the test conditions of the coating adherence test, ISO 9211-4 and ECSS-Q-ST-70-13 can be used.

- c. The adhesive tape used for this test shall be clear in colour with an adhesive strength on steel of at least 0,28 N/mm.

NOTE For measuring the adhesive strength on steel, EN 1939 can be used.

- d. Any visible delamination of parts of the contacts or the anti-reflection coating shall not exceed the limits specified in clauses 7.5.1.4 and 7.5.1.5.

## **7.5.9 Contact uniformity (CU)**

### **7.5.9.1 Purpose**

The contact uniformity test verifies the uniformity of the thickness of the solar cell contacts during qualification.

### **7.5.9.2 Process**

- a. The uniformity of the thickness of the metal contact in the interconnector weld area shall be checked with a step-height profiler for instance a betascope or a similar instrument as stated in the SCD-BSC.

### **7.5.9.3 Pass fail criteria**

- a. The uniformity of the contact thickness of the metal layers of the cell contact shall conform to the requirements of the interconnection process (as stated in the SCD-BSC).

## **7.5.10 Contact thickness (CT)**

### **7.5.10.1 Purpose**

The contact thickness test verifies the thickness of the solar cell contacts during acceptance test.

### **7.5.10.2 Process**

- a. The thickness of the solar cell metal contact in the interconnector weld area or on dedicated in-process test samples shall be checked with a step-height profiler, as stated in the SCD-BSC.

NOTE For example, with a betascope or a similar instrument.

### **7.5.10.3 Pass fail criteria**

- a. The thickness of the metal layers of the cell contact shall conform to the requirements of the interconnection process (as stated in the SCD-BSC).

## **7.5.11 Surface finish (SF)**

### **7.5.11.1 Purpose**

The surface finish test verifies the surface finish of the solar cell contacts during qualification test.

### **7.5.11.2 Process**

- a. The surface finish in the interconnector weld area shall be checked with a micro surface-roughness tester.

### 7.5.11.3 Pass fail criteria

- a. The surface finish of the metal layers of the cell contact shall conform to the requirements of the interconnection process (as stated in the SCD-BSC).

## 7.5.12 Pull test (PT)

### 7.5.12.1 Purpose

The objective of the pull test is to check the bond strength of the front and rear side contacts under mechanical and environmental stress.

### 7.5.12.2 Process

- a. A gradually increasing pull force shall be applied to the interconnector tabs at a pull speed as stated in the SCD-BSC.
- b. The ultimate pull strength of each tab shall be as stated in the SCD-BSC.
- c. The pull direction shall:
  1. be either 0°, 45° or 90°;
  2. be as stated in the SCD-BSC.
- d. The type of failure shall be recorded.

## 7.5.13 Electron irradiation (EI)

### 7.5.13.1 Purpose

This test is an accelerated life test to check the solar cell performance degradation under electron particle irradiation.

### 7.5.13.2 Process

- a. The solar cells shall be subjected to 1 MeV electron irradiation.

NOTE ISO 23038 outlines a methodology to perform this test.
- b. The flux density and energy shall be uniform over the cell area within  $\pm 10\%$ .
- c. During irradiation, the cells shall be protected from oxidation, using either vacuum (below  $10^{-3}$  Pa) or a dry atmosphere of nitrogen or argon at a temperature of  $(20 \pm 10)$  °C.
- d. The nominal rate shall be lower than  $5 \times 10^{11}$  e<sup>-</sup> cm<sup>-2</sup> s<sup>-1</sup>.
- e. For general characterization of solar cells (subgroup C1):
  1. The dosages stated in the SCD-BSC (for specific cell types and to cover typical applications) shall be applied;

2. only cells from mid-grade shall be used (in conformance with requirement 7.4.2.2c).
- f. For mission specific qualification (Subgroup C2) the irradiation shall be performed as follows:
  1. State the expected dose for the envisaged application,  $\Phi_p$ , in the SCD-BSC.
  2. Divide subgroup C2 (in conformance with Table 7-2) in two batches of 12 samples as a minimum, constituted as follows (in conformance with requirement 7.4.2.2c):
    - (a) a minimum of 8 mid-grade cells;
    - (b) a minimum of 2 high-grade cells;
    - (c) a minimum of 2 low-grade cells.
  3. Irradiate the batches specified in requirement 7.5.13.2f.2 as follows:
    - (a) the first batch, twice at  $\Phi_p$ ;
    - (b) the second batch, twice at  $\Phi_p/2$ .

NOTE This results in data for 12 samples at  $\Phi_p/2$ , at  $\Phi_p \times 2$ , and data for 24 samples at  $\Phi_p$ .
- g. After electron irradiation, photon irradiation and temperature annealing, the requirements in requirement 7.5.3.2e shall be satisfied.
- h. Electron irradiation at a dose corresponding to the dose at transfer orbit (as stated in the SCD-BSC) shall be added.

## 7.5.14 Proton irradiation (PI)

### 7.5.14.1 Purpose

The purpose of this test is to monitor the degradation of solar cell performance under proton particle irradiation.

### 7.5.14.2 Process

- a. Subgroup P shall be constituted as follows (in conformance with requirement 7.4.2.2d):
  1. 4 high-grade solar cells,
  2. 16 mid-grade solar cells and
  3. 4 low-grade solar cells.

NOTE See cell grading in SCD-BSC.
- b. The solar cells shall be subjected to a fluence, of  $X_1$  and  $X_2$  MeV proton radiation, where  $X_1$  and  $X_2$  are as stated in the SCD-BSC.

NOTE Usually, the total radiation flux for a particular space environment (including all particles and energies) is translated into an equivalent dose of 1 MeV electrons.

- c. Two proton energies shall be used in order to confirm the validity of the calculated equivalent dose of 1 MeV electrons.
- d. The flux of the proton irradiation, in  $p^+ \text{ cm}^{-2} \text{ s}^{-1}$ , shall be as stated in the SCD-BSC.

### **7.5.15 Photon irradiation and temperature annealing (PH)**

#### **7.5.15.1 Purpose**

This test is to verify the stability of solar cell performance under the equivalent light and temperature of 1 S.C. (AM0).

#### **7.5.15.2 Process**

- a. During the test, solar cells of subgroups B, C1, C2 and P shall be subjected to the following:
  - 1. irradiated with 1 S.C. (AM0) for 48 h;
  - 2. be kept at  $(25 \pm 5) \text{ }^\circ\text{C}$ ;
  - 3. be in an open circuit condition.
- b. The cells shall be subsequently temperature annealed for 24 h at  $60 \text{ }^\circ\text{C}$ .
- c. After the tests, the cells shall be kept at temperatures below  $50 \text{ }^\circ\text{C}$  until they are electrically measured.

### **7.5.16 Solar cell reverse bias test (RB)**

#### **7.5.16.1 Purpose**

The purpose of solar cell reverse bias test is to check for performance degradation of the solar cell due to reverse bias.

#### **7.5.16.2 Process**

- a. For solar cells without a protection diode or with a protection diode electrically isolated from the cell, the process shall be as follows:
  - 1. Measure the reverse I/V characteristics of the bare solar cell under illumination of 1 S.C. (AM0) with a limiting power supply (to avoid destructive breakdown).
  - 2. Ensure that the parameters of reverse I/V characteristics measurement are as stated in the SCD-BSC concerning temperature, hold time, current limitation, maximum reverse bias (voltage).
- b. For solar cells with a protection diode electrically connected to the cell, solar cell reverse bias test shall not be applied.

### **7.5.16.3 Pass-fail criteria**

- a. Solar cell reverse bias test shall satisfy the pass-fail criteria stated in the SCD-BSC.

## **7.5.17 Thermal cycling (CY)**

### **7.5.17.1 Purpose**

The purpose of this test is to assess the reliability of test samples under a thermal stress equivalent of one year in orbit.

### **7.5.17.2 Process**

- a. The number of cycles and the extreme temperatures shall be those stated in the SCD-BSC.

## **7.5.18 Active-passive interface evaluation test (IF)**

### **7.5.18.1 Purpose**

This test is performed to determine if the single junction GaAs-Ge cell has got an active or passive interface layer.

### **7.5.18.2 Process**

- a. Test in clause 7.5.3 shall be repeated using a non infrared-rich simulator having a maximum deviation of the total energy in the spectral region of  $0,8\ \mu\text{m}$  to  $1,1\ \mu\text{m}$  (as described in clause 10.1.1) of a percentage value stated in the SCD-BSC.
- b. The delta value of the open circuit voltage of bare cells with an active interface under the two solar simulator conditions (1 S.C (AM0) and non-infrared rich) shall be less than the value stated in the SCD-BSC.

## **7.5.19 Flatness test (FT)**

### **7.5.19.1 Purpose**

The purpose of this test is to determine the flatness of the bare solar cell.

### **7.5.19.2 Process**

- a. The flatness shall be determined by measuring the maximum deflection,  $d$ , of the bare solar cell measured on an optically flat surface with an orientation and method as stated in the SCD-BSC.

### **7.5.19.3 Pass/fail criteria.**

- a. The deflection of the bare cell shall be lower than the deflection value stated on the SCD-BSC.

## 7.6 Failure definition

### 7.6.1 Failure criteria

- a. The following shall constitute failures:
  1. Components that fail during subgroup tests for which the pass-fail criteria are inherent in the test method.
  2. Components failing to conform to the requirements of visual inspection stated in the SCD-BSC.
  3. Components whose marking fails to conform to the requirements of clause 7.1.3.
  4. Components that, when subjected to electrical performance measurements after acceptance tests in conformance with the SCD-BSC, fail to meet one or more of the specified limits, measurement accuracy included.

### 7.6.2 Failed components

- a. A component shall be considered to have failed if it exhibits one or more of the failure modes specified in clause 7.6.1.
- b. Failed components shall be identified as such and included in the delivery.
- c. Failure analysis of these components shall be performed by the supplier and the results provided to the customer as part of an NRB documentation.

NOTE For NRB, see ECSS-Q-ST-10-09.

## 7.7 Data documentation

- a. The supplier shall provide a data documentation package (DDP) in conformance with Annex G, for the qualification approval records and for each component delivery lot.

## 7.8 Delivery

- a. All deliverable hardware specified in the order shall be delivered together with documentation in conformance with the requirements specified in clause 7.7.
- b. One set of documents shall be sent to the customer.

## **7.9 Packing, dispatching, handling and storage**

### **7.9.1 Overview**

For packaging, dispatching, handling and storage of components see ESA-PSS-01-202.

### **7.9.2 ESD Sensitivity**

- a. If a bare cell is sensitive to ESD according to clause 5.2 of ESCC 23800 Issue 1 then it shall be handled and stored according to ESCC 24900 Issue 2, clause 10.



# 8 Coverglasses

---

## 8.1 Overview

### 8.1.1 Purpose

This Clause defines the generic requirements for the manufacture, test and qualification of coated coverglasses (CVG) for solar cell photovoltaics in the space environment and the requirements to guarantee the performance of a manufacturing lot.

This Clause, along with the source control drawing for coverglasses (SCD-CVG) and process identification document, defines the performance requirements for the coverglass component.

### 8.1.2 Description

The coverglasses are designed for use as a transparent protective shield for a range of solar cells.

Coverglass substrates are either made of fused silica or a borosilicate microsheet. The latter has a nominal concentration of cerium dioxide to increase the radiation stability of the coverglass and selectively filter out the short wavelength ultraviolet radiation to protect the underlying coverglass bonding adhesive. In the case of fused silica, a UV reflective coating is used to protect the underlying adhesive.

The glass is defined by its elemental composition, which is measured throughout the production cycle to ensure consistent physical characteristics.

## 8.2 Interfaces

- a. The design of the coverglasses shall enable bonding to solar cells with space qualified adhesives.

## 8.3 Testing, deliverable components and marking

### 8.3.1 Testing

#### 8.3.1.1 Tests for qualification and procurement

- a. Tests for qualification of coverglasses shall comprise acceptance and qualification tests.
- b. Tests for procurement of qualified coverglasses shall comprise acceptance tests.

#### 8.3.1.2 Conditions and methods of tests

- a. The conditions and methods of testing shall conform to the coverglass source control drawing (SCD-CVG).

NOTE The coverglass specification consists of two parts, this Standard and the SCD-CVG. For the preparation of the SCD-CVG, refer to Annex D.

- b. The SCD-CVG shall be prepared by the supplier in conformance with Annex D and provided to the customer for reviewing and agreement.
- c. Any deviation from in-process, acceptance and qualification test procedures shall be justified in the SCD-CVG.
- d. Deviations from this Standard applicable to the SCD-CVG shall:
  1. be agreed between the customer and the supplier;
  2. include alternative requirements equivalent to those of this Standard;
  3. not affect the reliability and performances of the coverglasses;
  4. only be those specified in requirement 8.3.1.2c.

#### 8.3.1.3 Responsibility of supplier for the performance of tests and inspections

- a. The supplier shall ensure that the tests and inspections are performed.
- b. These tests and inspections shall be performed at the plant of the manufacturer or at a facility approved by the customer.

NOTE For test house requirements, see ECSS-Q-ST-20-07.

### 8.3.2 Deliverable components

- a. Delivered coverglasses shall be processed and inspected in conformance with the requirements of the process identification document (PID) defined in clause 8.4, and
- b. Delivered coverglasses shall have completed all tests and inspections stated in the SCD-CVG.

### 8.3.3 Marking (coating orientation)

- a. The coated face of the component shall be identified.

NOTE This requirement can be satisfied using for instance one of the methods shown in Figure 8-1. or equivalent.

- b. The orientation method along with associated dimensional tolerances shall be stated in the SCD-CVG.

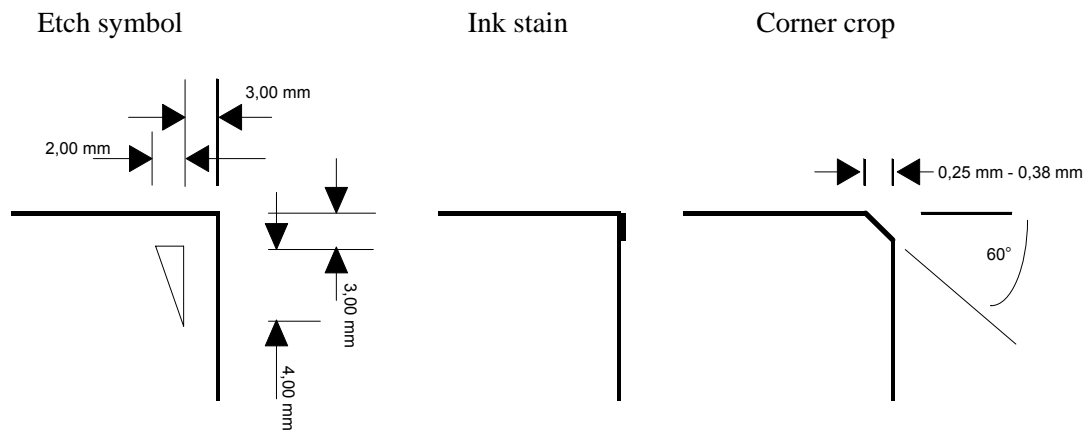

Figure 8-1: Methods of defining coverglass orientation

## 8.4 Production control (Process identification document)

- a. A process identification document (PID) for the coverglasses to be qualified shall be prepared by the supplier in conformance with Annex F.
- b. The supplier shall do the following:
1. maintain configuration control of all documents;
  2. keep the issues of the documents effective at the date of acceptance by the customer;
  3. provide the PID to the customer for review;
  4. submit to the customer for review and approval any modifications or changes to documents in the PID with any quality and reliability implications.

## 8.5 Acceptance tests

### 8.5.1 Acceptance test samples

- a. A minimum of 40 test samples shall be selected statistically and at random from the shipment lot.
- b. Sample size may be modified depending on specific project requirements, as stated in SCD-CVG.

NOTE For sampling see ISO 2859.

### **8.5.2 Acceptance test sequence**

- a. Acceptance tests shall be performed on the following:
  1. components for delivery;
  2. components used for qualification.
- b. Acceptance tests shall consist on the following:
  1. Submit 50 % of the samples (as selected in clause 8.5.1) to the following tests:
    - (a) transmission into air;
    - (b) dimensions;
    - (c) weight;
    - (d) thickness.
    - (e) flatness
  2. Submit the remaining 50 % of the samples (as selected in clause 8.5.1) to the following tests:
    - (a) visual inspection and transmission into air;
    - (b) humidity and temperature HT2;
    - (c) visual inspection and transmission into air;
    - (d) abrasion resistance;
    - (e) visual inspection;
    - (f) thermal cycling;
    - (g) coating adhesion;
    - (h) visual inspection.
- c. The data documentation corresponding to the tests referred in requirement 8.5.2b shall be delivered together with the delivered coverglasses and the qualification test sub-lot.

### **8.5.3 Test methods and conditions**

- a. The test methods and conditions shall conform to clause 8.7.

### **8.5.4 Documentation**

- a. Documentation on acceptance tests shall conform to clause 8.9.

## 8.6 Qualification tests

### 8.6.1 General

- a. Qualification shall be granted by the customer.
- b. All coverglass procurement lots shall be qualified.
- c. If a purchase order is placed for a procurement lot of a previously qualified coverglass, the qualification tests need not to be repeated if the following conditions are satisfied:
  1. No changes are made to the design, function or mechanical parameters of the coverglass.
  2. The same SCD-CVG is applicable.
  3. No changes are made to the PID.
- d. Qualification shall consist of the tests specified in Table 8-1.
- e. The supplier shall provide details of the outcome of the qualification programme to the customer.

### 8.6.2 Qualification

#### 8.6.2.1 Production and test schedule

- a. Before starting production of the qualification lot, the manufacturer shall compile a production test schedule, showing by date and duration, production and test activities, including all major processing operations and key stages in the production and testing.
- b. Process schedules and inspection procedures shall be provided.

#### 8.6.2.2 Qualification test samples

- a. The supplier shall provide access to the customer to monitor the manufacture of the coverglass qualification set.
- b. The coverglass qualification set shall be chosen statistically and at random from the first coating lots, as stated in the SCD-CVG.

NOTE For sampling see ISO 2859.

#### 8.6.2.3 Qualification testing

- a. Qualification testing shall proceed as given in Table 8-1, with the following conditions:
  1. The total quantity of test samples (in Table 8-1) shall be agreed between the customer and supplier.

NOTE For example, 20 coverglasses for each subgroup and 5 for every radiation dose.

2. The qualification tests shall be divided into subgroups of tests.

3. The samples assigned to a subgroup shall be subjected to the tests in that subgroup in the sequence specified.
  - b. A failure in any subgroup shall constitute a failure in the qualification.

**Table 8-1: Qualification test plan for coverglases**

Test	Symbol	Method	Un-coated	Coated or uncoated coverglases						
			A (20)	B (20)	U (20)	O (20)	V (20)	C (20)	P (20)	S (10)
Visual inspection	VI	8.7.1	1	1	1,4	1,4,7,9,12	1,4	1,4	1,4	
Transmission into air	TA	8.7.2	2	2	2,5	2,5,10	2,5	2,5	2,5	
Electro-optical properties	EO	8.7.3	3	3						
Mechanical properties	MP	8.7.4		4						
Reflectance properties	OP	8.7.5		5						
Normal emittance	NE	8.7.6		6			6	6	6	
Surface resistivity	SC	8.7.7		7			7	7	7	
Flatness	FT	8.7.8		8						
Transmission into adhesive	TH	8.7.9		9						
Boiling water	BW	8.7.10			3					
Humidity and temperature <sup>1</sup>	HT1	8.7.11.1				3				
UV exposure	UV	8.7.12					3			
Electron irradiation	EI	8.7.13						3		
Proton irradiation	PI	8.7.14							3	
Breaking strength	BS	8.7.15								1
Thermal cycling	CY	8.7.16				8				
Abrasion resistance	AE	8.7.17				6				
Coating adhesion	TD	8.7.18				11				

NOTE 1 The numbers in the subgroup columns indicate the sequence in which the tests are performed; e.g. for subgroup A, the 1st test is VI, the 2nd test TA, the 3rd is EO, and so on.

NOTE 2 The reason for dividing the test samples into subgroups is to generally test for the following:

- Subgroup A: Physical properties of coverglass substrate material
- Subgroup B: Mechanical properties and BOL data
- Subgroup U: Coating adherence (Solubility)
- Subgroup O: Humidity and temperature coating stability
- Subgroup V: UV exposure
- Subgroup C: Electron irradiation
- Subgroup P: Proton irradiation
- Subgroup S: Breaking strength

## 8.7 Test methods, conditions and measurements

### 8.7.1 Visual inspection (VI)

#### 8.7.1.1 General

- a. All the coverglasses shall be visually inspected with the naked eye to verify the requirements for defects on coverglasses in conformance with clause 8.7.1.2.

#### 8.7.1.2 Deviations

- a. Any deviation from the visual inspection requirements on defects in clause 8.7.1.3 shall:
  1. not affect performance or reliability,
  2. be agreed with the customer, and
  3. be justified.

#### 8.7.1.3 Defects

##### 8.7.1.3.1 Coated coverglasses

- a. The coated area shall have a uniform appearance, with no visible evidence of pinholes, voids or spatter.

NOTE See MIL-PRF-13830.

- b. For a coated coverglass, the uncoated area due to coating tools shall not exceed 1 % of the total coverglass area or 8 mm<sup>2</sup>, whichever is greater.

##### 8.7.1.3.2 Scratch and dig

- a. The maximum dimensions of scratches and digs shall be stated in the SCD-CVG.

NOTE See MIL-PRF-13830.

##### 8.7.1.3.3 Bubbles and inclusions

- a. The projected area of any bubble or inclusions in the coverglass shall not be larger than 0,02 mm<sup>2</sup>.

NOTE See MIL-PRF-13830.

##### 8.7.1.3.4 Edge chips

- a. The projection into the coverglass face, defined by "b" in Figure 8-2, shall not exceed 0,25 mm.
- b. The length of the chip, defined by "a" in Figure 8-2, shall not exceed 0,6 mm.
- c. Edge chips with a dimension of the projection into the coverglass face of  $b < 0,1$  mm and a length of the chip  $a < 0,2$  mm (in conformance with Figure 8-2) may be ignored.

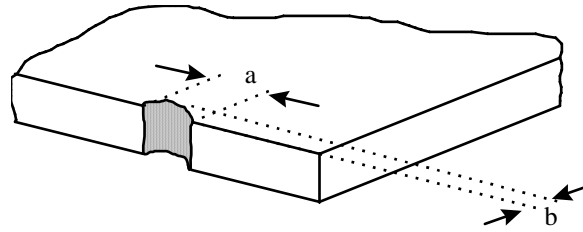

**Figure 8-2: Edge chip parameters**

#### 8.7.1.3.5 Corner chips

- a. The length of the hypotenuse, as defined by “d” in Figure 8-3, of any corner chip in the coverglass, shall not exceed 0,75 mm.
- b. The SCD-CVG shall state a requirement specifying the maximum number of chips per coverglass.

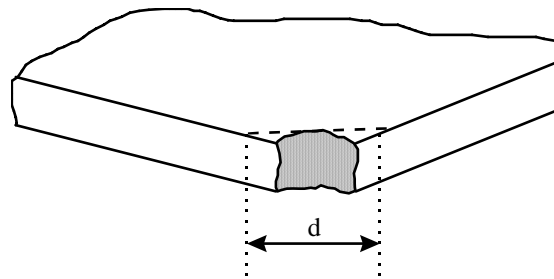

**Figure 8-3: Corner chip parameters**

#### 8.7.1.3.6 Cracks

- a. Surface, edge or corner cracks shall not be present on a coverglass.

NOTE For further information, see MIL-PRF-13830.

#### 8.7.1.3.7 Dirty and contaminated surfaces

- a. Coverglasses shall not have dirty or contaminated surfaces.

NOTE For further information, see MIL-PRF-13830.

### 8.7.2 Transmission into air (TA)

- a. The transmission into air of the coverglass shall be measured (for  $\lambda$  and T in conformance with requirement 8.7.2b) using a calibrated spectrophotometer as follows:
  1. at an incidence angle of less than  $10^\circ$ ,
  2. with a wavelength tolerance of  $(\lambda \pm 2)$  nm, and
  3. an absolute transmission tolerance of  $(T \pm 1)$  %.
- b. The transmission values before and after testing shall be specified in the SCD-CVG for the following:
  1. Discrete wavelength: 400 nm, 450 nm, 500 nm and 600 nm.
  2. Wavelength range: (300 - 320) nm, (400 - 450) nm, (600 - 800) nm, (450 - 1100) nm and (900 - 1800) nm.



## 8.7.3 Electro-optical properties (EO)

### 8.7.3.1 Bulk and surface resistivity

- a. The values and tolerances of the bulk resistivity and surface resistivity, derived from an electrical measurement made between two geometrically defined, evaporated electrical contacts on the glass substrate, shall be stated in the SCD-CVG.

### 8.7.3.2 Refractive index

- a. The values and tolerances of the refractive index, measured using the following V-block refractometer method, shall be stated in the SCD-CVG:
  1. Prepare the samples by cutting 22 mm × 22 mm square samples and clamp them together to give a small block approximately 6 mm in thickness.
  2. Place this block into the V of a V-block prism made of a glass of refractive index similar to that of the sample under test.
  3. To achieve the optical contact, use a matching refractive index fluid.
  4. Measure first a reference block of known refractive index in order to calibrate the apparatus.

NOTE The instrument gives an absolute measurement referenced to this Standard with an accuracy better than  $\pm 10^{-4}$  over the range of 1,47 to 1,65.

5. Use a sodium d-line as the light source.

## 8.7.4 Mechanical properties

### 8.7.4.1 Dimension and weight

- a. The dimensions and associated tolerances of the coverglass shall be stated in the SCD-CVG and conform to the tolerance limits defined in Figure 8-4.
- b. The values and tolerances of the weight of the coverglass, verified by determining the average weight per shipping lot, shall be as stated in the SCD-CVG.

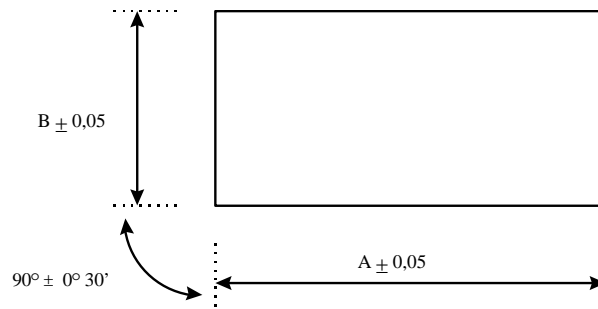

**Figure 8-4: Coverglass manufacturing tolerance limits**

#### 8.7.4.2 Density

- a. The density and tolerances of a sample of the glass, weighed in air and water using an analytical balance at 25 °C, shall conform to the requirements stated in the SCD-CVG.

NOTE Density is calculated from the measured specific gravity and the density of water at 25 °C.

#### 8.7.4.3 Thickness

- a. The coverglass thickness along with the associated tolerances shall be as stated in the SCD-CVG.
- b. The thickness shall be measured using a calibrated micrometer.

#### 8.7.4.4 Edge parallelism

- a. The edge parallelism shall be as stated in the SCD-CVG.
- b. The edge parallelism shall be measured using a calibrated micrometer.

#### 8.7.4.5 Perpendicularity of sides

- a. The perpendicularity of the sides of the coverglass shall be measured using an optical instrument with a reference normal.
- b. The perpendicularity shall be as stated in the SCD-CVG.

### 8.7.5 Reflectance properties (OP)

#### 8.7.5.1 Reflectance

- a. The reflectance shall be measured using a calibrated spectro-photometer using a W-reflectance method or integrating sphere.
- b. The wavelength tolerance shall be  $\lambda \pm 2$  nm and a reflectance tolerance of  $(R \pm 1)$  %, where  $\lambda$  and R are as stated in the SCD-CVG.

### 8.7.5.2 Reflectance cut-on

#### 8.7.5.2.1 Definition

The reflectance cut-on is defined as the wavelength that corresponds to 50 % absolute measured reflectance in the low wavelength side of the reflectance band.

#### 8.7.5.2.2 Purpose

The reflectance cut-on is used to measure high reflectance bands.

NOTE There can be more than one high reflectance band in the coated coverglass component.

#### 8.7.5.2.3 Requirement

- a. The reflectance cut-on shall be as stated in the SCD-CVG.

### 8.7.5.3 Reflectance cut-off

#### 8.7.5.3.1 Definition

The reflectance cut-off is defined as the wavelength that corresponds to 50 % absolute measured reflectance in the high wavelengths range of the reflectance band.

#### 8.7.5.3.2 Purpose

The reflectance cut-off is used to measure high reflectance bands.

NOTE There can be more than one high reflectance band in the coated coverglass component.

#### 8.7.5.3.3 Requirement

- a. The reflectance cut-off shall be as stated in the SCD-CVG.

### 8.7.5.4 Reflectance bandwidth

#### 8.7.5.4.1 Definition

The reflectance bandwidth is the width in nanometres measured between the reflectance cut-on and cut-off divided by the centre wavelength of the reflectance band which is defined with the following equation;

$$\lambda_c = \frac{2\lambda_1\lambda_2}{\lambda_1 + \lambda_2}$$

where

$\lambda_c$  is centre wavelength of the reflectance band;

$\lambda_1$  is the reflectance cut-on;

$\lambda_2$  is the reflectance cut-off.

#### 8.7.5.4.2 Requirement

- a. The reflectance bandwidth shall be as stated in the SCD-CVG.

### 8.7.6 Normal emittance ( $e_N$ ) (NE)

- a. The normal emittance shall be measured according to ECSS-Q-ST-70-09.
- b. The normal emittance shall be as stated in the SCD-CVG.

### 8.7.7 Surface resistivity

- a. When a conductive coating is incorporated in the coverglass, the surface resistivity shall be measured, using the equipment stated in the SCD-CVG, as follows:
  1. Measure the resistance between two indium-tin soldered buzzbars applied to the coverglass, as shown in Figure 8-5.
  2. Calculate the surface resistivity from the resistance and the length  $a$ , and  $b$ , defined in Figure 8-5 using the following equation:

$$R_s = (aR) / b$$

where

$R$  is the measured resistance;

$R_s$  is the surface resistivity.

- b. The surface resistivity shall conform to the requirements defined in the SCD-CVG.

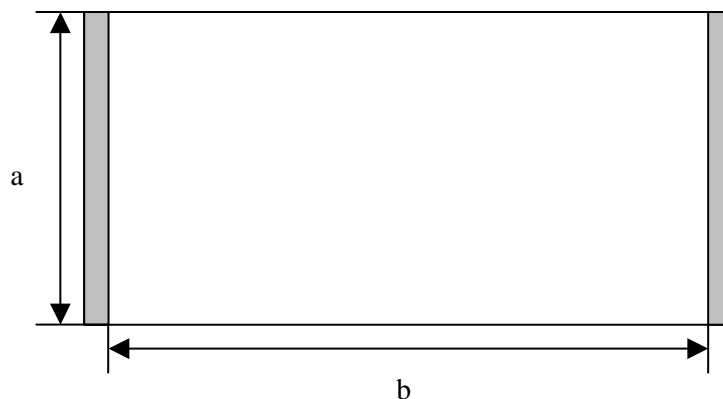
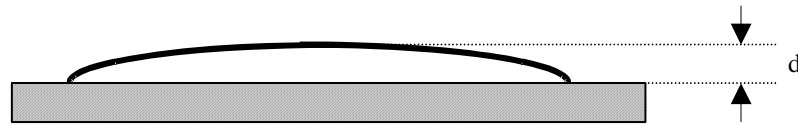

Figure 8-5: Schematic for calculating surface resistivity

### 8.7.8 Flatness or bow (FT)

- a. Flatness or bow shall be measured by measuring the maximum deflection,  $d$  (as stated in the SCD-CVG) of the coverglass measured on an optically flat surface in the orientation shown in Figure 8-6.
- b. For localized flatness deformations, the maximum displacement of the coverglass from an optically flat surface over a specified distance shall not exceed the values stated in the SCD-CVG.



**Figure 8-6: Definition of coverglass flatness**

### 8.7.9 Transmission into adhesive (TH)

- a. The transmission into the adhesive shall be measured as in clause 8.7.2, using a fused silica or uncoated coverglass backing piece laminated onto the coverglass component and a matching fluid with a refractive index of 1,41.
- b. The transmission shall be corrected for reflectance losses at the backing piece-air interface by using Fresnel's equation as stated in the SCD-CVG.
- c. The transmission into adhesive values shall be as stated in the SCD-CVG.

### 8.7.10 Boiling water test (BW)

- a. The single-coated coverglass shall be immersed in boiling de-ionized water for a minimum continuous period of:
  1. 5 minutes for multi-layer coated coverglasses;
  2. 15 minutes in any other case.

### 8.7.11 Humidity and temperature

#### 8.7.11.1 HT1 for qualification testing (subgroup O)

##### 8.7.11.1.1 Purpose

This test is an accelerated shelf-life test to monitor the stability of the coverglass coatings stability in a humid atmosphere.

##### 8.7.11.1.2 Process

- a. All coverglasses of subgroup O shall be placed in a chamber at ambient pressure.
- b. The chamber temperature shall then be increased from ambient temperature to 50 °C at a minimum.
- c. Relative humidity shall be higher than 90 %.
- d. The duration of the test shall be 10 days.
- e. High-purity water in conformance with ASTM D1193-99, Type I, shall be used.
- f. Water condensation on the surface of the coverglasses shall be prevented.
- g. If there are requirements on specific environmental conditions they shall be stated in the SCD-CVG.

NOTE For example, requirements on chemical vapours.

## 8.7.11.2 HT2 for acceptance testing

### 8.7.11.2.1 Purpose

This test is to verify the adherence of coatings to the coverglass.

### 8.7.11.2.2 Process

- a. All coverglasses shall be placed in a chamber at ambient pressure.
- b. The chamber temperature shall then be increased from ambient temperature to 50 °C at a minimum.
- c. Relative humidity shall be higher than 90 %.
- d. The duration of the test shall be 72 h.
- e. High-purity water in conformance with ASTM D1193-99, Type I, shall be used.
- f. Water condensation on the surface of the cells shall be prevented.
- g. If there are requirements on specific environmental conditions, they shall be stated in the SCD-CVG.

NOTE For example, requirements on chemical vapours.

## 8.7.12 UV exposure (UV)

### 8.7.12.1 Purpose

This test is an accelerated shelf-life test with the purpose of checking the stability of the coverglass coatings under ultraviolet light exposure.

### 8.7.12.2 Process

- a. The integrated intensity of the photons shall be measured with a Sun-blind photo-diode.
- b. For photons with a wavelength between 200 nm to 400 nm, the integrated intensity at the end of test shall be as follows:
  1. equal to (1000 - 1500) Sun-hours or 1 % of the mission life, whichever is the longer period;
  2. have an UV irradiation acceleration factor of less than 10 S.C. (AM0).

NOTE For photons with a wavelength between 200 nm to 400 nm, spectral irradiance requirements for UV light sources are defined in ECSS-Q-ST-70-06.

- c. The test shall be performed in a vacuum (i.e. pressure less than  $10^{-3}$  Pa).
- d. The temperature of the coverglass shall be kept below 60 °C during the test.
- e. Control samples shall be included the UV chamber in order to identify potential contaminations occurring during the test.

## 8.7.13 Electron irradiation (EI)

### 8.7.13.1 Purpose

This test is an accelerated shelf-life test with the purpose of checking coverglass coating stability under electron particle irradiation.

### 8.7.13.2 Process

- a. The coverglasses shall be subjected to 1 MeV electron irradiation.
- b. If the front surface coating is tested, low electron energies shall be used.
- c. The flux density and energy shall be uniform over the coverglass area to within  $\pm 10\%$ .
- d. The nominal rate shall be lower than the value stated in the SCD-CVG.
- e. Tests shall be performed in vacuum (pressure below  $10^{-3}$  Pa) or in inert gas atmosphere.
- f. The irradiation shall be performed at doses representative of LEO and GEO mission environments and at least  $2 \times \Phi_p$ , as stated in the SCD-CVG.

## 8.7.14 Proton irradiation (PI)

### 8.7.14.1 Purpose

This test is an accelerated shelf-life test with the purpose of verifying the stability of coverglass and its coatings under proton particle irradiation.

### 8.7.14.2 Process

- a. The coverglasses shall be subjected to a proton irradiation of high and low energies according to dose and energy values stated in the SCD-CVG.
- b. The proton energy shall be uniform over the coverglass area within  $\pm 10\%$ .
- c. The nominal flux ( $p^+ \text{ cm}^{-2} \text{ s}^{-1}$ ) shall be uniform within  $\pm 10\%$  and be lower than or equal to the value stated in the SCD-CVG.
- d. Tests shall be performed in a vacuum (pressure below  $10^{-3}$  Pa).

## 8.7.15 Breaking strength (BS)

- a. The coverglass breaking strength shall exceed the limits set in the SCD-CVG.
- b. The breaking strength test method shall be as stated in the SCD-CVG.

### 8.7.16 Thermal cycling (CY)

- a. The coverglasses shall be exposed to the number of cycles over the range of temperature (both as stated in the SCD-CVG) with a total cycle duration not greater than 10 minutes.
- b. After exposure, the coverglasses shall show no signs of physical degradation when inspected in conformance with a standard agreed with the customer  

NOTE Example of such a standard is MIL-PRF-13830.
- c. The coverglasses shall show no degradation in the measured optical performance.

### 8.7.17 Abrasion resistance (coated surface) (AE)

- a. The coverglass shall be subjected to 20 strokes with a 6 mm diameter pencil type eraser conforming to MIL-E-12397B, loaded to 10 N.
- b. The coverglass shall show no evidence of physical degradation.

### 8.7.18 Coating adhesion (TD)

- a. The coverglass shall be subjected to an adhesion test in conformance with a standard agreed with the customer.  

NOTE An example of such a standard is ECSS-Q-ST-70-13.
- b. The coating shall show no evidence of delamination.  

NOTE For further guidance, see also MIL-M-13508.

## 8.8 Failure definition

### 8.8.1 Failure criteria

- a. The following shall constitute failures:
  1. Components that fail during subgroup tests for which the pass-fail criteria are inherent in the test method.
  2. Components failing to conform to the requirements of visual inspection stated in the SCD-CVG.
  3. Deviation between the group B, transmission into air, normal emittance and surface resistivity characterization (BOL) and the identical test after exposure in subgroups V, C and P, that are not within the measurement accuracy of the used characterization equipment.



### **8.8.2 Failed components**

- a. A component shall be considered as failed if it exhibits one or more of the failure modes specified in clause 8.8.1.
- b. Failed components shall be identified as such and included in the delivery.
- c. Failure analysis of these components shall be performed by the supplier and the results provided to the customer as part of an NRB documentation.

NOTE For NRB, see ECSS-Q-ST-10-09.

## **8.9 Data documentation**

- a. The supplier shall provide a data documentation package (DDP) in conformance with Annex G for the qualification approval records and for each component delivery lot.

## **8.10 Delivery**

- a. All deliverable hardware specified in the order shall be delivered together with documentation in conformance with the requirements specified in clause 8.9.
- b. One set of documents shall be sent to the customer.

## **8.11 Packing, dispatching, handling and storage**

For packaging, despatching, handling and storage of components see ESA-PSS-01-202.

# 9

## Solar cell protection diodes

---

### 9.1 Overview

Multi-junction solar cells are protected with shunt diodes for safe performance in solar cell strings applied on solar panels for use in space. These protection diodes can be applied in different configurations:

- A separate external diode shunting the cell junctions
- An integral diode consisting of the same epitaxial design as the bare solar cell and connected to the next solar cell in the string
- An integral diode consisting of dedicated epitaxial design to be connected to the bare solar cell using interconnectors
- An integral diode consisting of dedicated epitaxial design which has been connected to the cell as part of the solar cell production process. This is called a monolithic protection diode

This clause gives guidelines for the specification of external and integral protection diodes, but does not take into account the monolithic protection diodes.

An integral protection diode can not be considered as a separate entity. All the tests and inspections done on the bare cell with which the diode forms an integral part are also applied to the diode. This chapter deals with the additional aspects of qualification and acceptance of the protection diode.

In this document BSC refers to Bare Solar Cell plus integral protection diode. EPD refers to external protection diode.

In case "SCD-BSC or SCD-EPD" is stated, it refers to the one applicable, i.e. to SCD-BSC in the case of integrated protection diode, or SCD-EPD in the case of external protection diode.

### 9.2 Testing, deliverable components and marking

#### 9.2.1 Testing

##### 9.2.1.1 Tests for qualification and procurement

- a. The qualification test programme for the protection diodes shall comprise both acceptance and qualification testing.

- b. Testing for the procurement of qualified protection diodes shall comprise acceptance tests and delta qualification tests in conformance with requirement 9.5.2g.

### **9.2.1.2 Conditions and methods of tests**

#### **9.2.1.2.1 Integral protection diodes (IPD)**

- a. For internal protection diodes, the test conditions and methods for BSC specified in clause 7.1.1.2 shall apply.

#### **9.2.1.2.2 External protection diodes (EPD)**

- a. The conditions and methods of external protection diode testing shall conform to the external protection diode source control drawing (SCD-EPD).

NOTE The external protection diode specification consists of two parts, the generic specification (this Standard) and the SCD-EPD. The SCD-EPD contains the technical specification for a diode type relevant to acceptance testing, as well as for the qualification testing. For the preparation of the SCD-EPD for external protection diodes, refer to Annex E, checklist for SCD-EPD.

- b. The SCD-EPD shall be prepared by the supplier in conformance with Annex E and provided to the customer for reviewing and agreement.
- c. Any deviation from the required in-process, acceptance and qualification tests shall be justified..
- d. Deviations from this Standard applicable to the SCD-EPD shall:
  - 1. be agreed between the customer and the supplier;
  - 2. include alternative requirements equivalent to those of this Standard;
  - 3. not affect the reliability and performances of the EPDs;
  - 4. only be those specified in requirement 9.2.1.2.2c.

### **9.2.1.3 Responsibility of supplier for the performance of tests and inspections**

- a. The supplier shall ensure that the tests and inspections specified in clauses 9.4 and 9.5 are performed.
- b. The tests and inspections specified in clauses 9.4 and 9.5 shall be performed at the manufacturer's plant or at a facility approved by the customer.

NOTE For test house requirements, see ECSS-Q-ST-20-07.

## **9.2.2 Deliverable components**

### **9.2.2.1 Integral protection diodes**

- a. Delivered integral protection diodes shall be processed and inspected in conformance with the requirements of the process identification document (PID) defined in clause 7.2, and
- b. Delivered integral protection diodes shall have completed all tests and inspections specified in the SCD-BSC.

### **9.2.2.2 External protection diodes**

- a. Delivered external protection diodes shall be processed and inspected in conformance with the requirements of the process identification document (PID) defined in clause 9.3, and
- b. Delivered external protection diodes shall have completed all tests and inspections specified in the SCD-EPD.

## **9.2.3 Marking**

- a. All delivered external protection diodes shall be marked in conformance with one of the following approaches, agreed with the customer:
  - permanently marked with a code to enable traceability of the diodes at the level specified in the SCD-EPD.
  - marked reduced to delivery batch level.

## **9.3 Production control (process identification document)**

### **9.3.1 Integral protection diodes**

- a. For integral protection diodes, requirements in clause 7.2 shall apply.

### **9.3.2 External protection diodes**

- a. The process identification document (PID) for the external protection diodes to be qualified shall be prepared by the supplier in conformance with Annex F.
- b. The supplier shall do the following:
  1. maintain configuration control of all documents;
  2. keep the issues of the documents effective at the date of acceptance by the customer;
  3. provide the PID to the customer for review;
  4. submit to the customer for review and approval any modifications or changes to documents in the PID

## 9.4 Acceptance tests

### 9.4.1 General

- a. Acceptance tests shall be performed on the following:
  1. components for delivery;
  2. components used for qualification.

### 9.4.2 Integral protection diodes

- a. Acceptance tests for integral protection diodes shall consist of the tests specified in Table 9-1.
- b. The humidity, temperature and contact pull tests of Table 7-1 shall also be performed on the integral protection diodes.

**Table 9-1: Acceptance test matrix IPD**

Test	Symbol	Verification method	Sample Size
Visual inspection	VI	9.6.2	100 %
Dimension	DW	9.6.3	1 %
Contact thickness	CT	9.6.8	1 %
Surface finish	SF	9.6.9	2 samples per delivery lot
Humidity and temperature, and pull	HT/PT	7.5.7.2 and 7.5.12	1 %
Diode characterization	DCA	9.4.5.2	100 %

### 9.4.3 External protection diodes

- a. Acceptance tests for external protection diodes shall consist of the tests specified in Table 9-2.

**Table 9-2: Acceptance test matrix EPD**

Test	Symbol	Verification method	Sample Size
Visual inspection	VI	9.6.2	100 %
Dimension and weight	DW	9.6.3	1 %
Contact Thickness	CT	9.6.8	1 %
Surface finish	SF	9.6.9	2 samples per delivery lot
Humidity and temperature	HT	9.6.6	1 %
Pull test	PT	9.6.11	1 %
diode characterisation	DCA	9.4.5.2	100 %

#### 9.4.4 External and integral diodes

- a. The generic specification to be used for acceptance tests shall be agreed with the customer.
- b. The sample size shall be in conformance with Table 9-1 (for IPD) or Table 9-2 (for EPD).
- c. If requirement 9.4.4b is not met, as the sample size shall be stated in SCD-BSC or SCD-EPD.
- d. The data documentation of acceptance tests shall be delivered together with the delivered cells/diodes and the qualification test lot.

#### 9.4.5 Test methods and conditions

##### 9.4.5.1 Production and test schedule

- a. The test methods and conditions shall conform to 9.6 except of DCA.

##### 9.4.5.2 Diode characterization for acceptance (DCA)

###### 9.4.5.2.1 Purpose

The purpose of diode characterization tests is to check the electrical performance of the diode.

###### 9.4.5.2.2 Process

- a. The forward and reverse I/V characteristic of the diode shall be recorded
  1. in darkness.
  2. with a limiting power supply (to avoid destructive breakdown), and
  3. with temperature control imposed (to avoid thermal runaway),
- b. Provision 9.4.5.2.2a shall be performed for the following variables, as stated in the SCD-BSC or SCD-EPD:
  1. At one temperature specified.
  2. Up to a forward current,  $I_{\text{DIODE-FORWARD}}$ , which is as a minimum, equal to 1,1 times the expected string current at solar array level at the corresponding temperature
  3. Up to a reverse voltage,  $V_{\text{DIODE-REVERSE}}$ , which is as a minimum, equal to 1,33 times the expected solar cell open circuit voltage at the corresponding temperature.
- c. In case of a integral protection diode the electrical isolation of cell and diode shall be tested by measuring the current when a voltage (as stated in the SCD-BSC) is applied between the front contacts of the protection diode and of the cell at the temperature as stated in the SCD-BSC

#### 9.4.5.2.3 Pass-fail criteria

- a. The diode characteristics test shall satisfy the pass-fail criteria stated in the SCD-BSC or SCD-EPD

### 9.4.6 Documentation

- a. Documentation on acceptance tests shall conform to clause 9.8.

## 9.5 Qualification tests

### 9.5.1 General

- a. Qualification shall be granted by the customer.

NOTE Qualification is only valid for the company who applied process and parameters for joining the interconnects to the diode.

- b. The supplier shall provide details of the outcome of the qualification programme to the customer.

### 9.5.2 Integral protection diodes

- a. The qualification of the diode shall be part of the bare solar cell and SCA qualification for the integral diode concept.
- b. For the qualification tests of integral protection diodes, Table 6-1 and Table 7-2 shall be applied.
- c. The qualification plan shall consist of the tests specified in Table 9-3.
- d. The subgroup A tests applicable for bare solar cells shall be done on the integral protection diodes also.
- e. The integral protection diodes shall be equipped with front interconnectors as step 7 in Table 7-2.
- f. The subgroups L, S and H tests shall be done on integral protection diodes with interconnects and either with or without coverglass (SCA level) and cell carrier.
- g. For a procurement lot of previously qualified solar cells with integral diodes, the qualification tests need not be repeated if the following conditions are satisfied:
  1. No changes are made to the design, function or electrical or mechanical parameters of the bare solar cell and integral protection diode.
  2. The same source control drawing is applicable.
  3. No changes are made to the PID.
  4. Delta qualification tests are performed to cover the requirements imposed by the new application.

- h. The new requirements referred in 9.5.2g.4 shall be included in a new version of the SCD-BSC.

**Table 9-3: Qualification test plan for integral protection diode**

Test	Symbol	Method	(48)	
			L (20)	H (8)
Welding of interconnectors <sup>2)</sup>	WI	See Note 2	1	1
Visual inspection	VI	9.6.2	2,13	2,9
Dimensions	DW	9.6.3	3	3
Burn-in	BI	9.6.5	5	5
Diode characterisation	DC	9.6.15	4,6,8,10,12	4,6,8
ESD	DE	9.6.16		7
Switching	DS	9.6.17	7,11	
Life	DL	9.6.18	9	
NOTE 1 Objectives of subgroups: Subgroup L: Protection diode life test and switching Subgroup H: Protection diode ESD test NOTE 2 Integrate the front interconnector to the integral diode				

### 9.5.3 External protection diodes

- a. The qualification plan shall consist of the tests specified in Table 9-4.
- b. During the qualification, all external protection diodes shall be equipped with n- and p-interconnectors, except for the diodes of subgroup O.
- c. For a procurement lot of a previously qualified external protection diodes, the qualification tests need not be repeated if the following conditions are satisfied:
1. No changes are made to the design, function or electrical or mechanical parameters of the external protection diode.
  2. The same source control drawing is applicable.
  3. No changes are made to the PID.
  4. Delta qualification tests are performed to cover the requirements imposed by the new application.
- d. The new requirements referred in 9.5.3c.4 shall be included in a new version of the SCD-EPD.



**Table 9-4: Qualification test plan for external protection diodes**

Test	Symbol	Method	Bare external protection diodes (84)			
			C(24)	O (20)	A(20)	V (20)
Welding of Interconnectors	WI	<sup>2)</sup>	1	<sup>3)</sup>	5	1
Visual inspection	VI	9.6.2	2,6,10,13	1,5,8,11,13	1,6,9,12,15	2,6,14
Dimensions & Weight	DW	9.6.3	3	2	2	3
Diode Characterisation	DC	9.6.15	4,7,11,14	3,6,9	7,10,13	4,7,9,11,13
Thermal Cycling	CY	9.6.4		4		
Burn in	BI	9.6.5	5	7	8	5
Humidity & Temperature	HT	9.6.6		10		
Contact uniformity	CU	9.6.7			3	
Surface Finish	SF	9.6.9			4	
Contact adherence	CA	9.6.10		12		
Pull	PT	9.6.11			14	
Electron Irradiation	EI	9.6.12	9			
Temperature annealing	TA	9.6.13	12			
Temperature behaviour	TB	9.6.14	8,15			
ESD	DE	9.6.16			11	
Switching	DS	9.6.17				8,12
Life	DL	9.6.18				10
<p>NOTE 1 Objective of subgroups            Subgroup C: Electron irradiation            Subgroup O: Extended storage simulation            Subgroup A: Contact adherence and ESD            Subgroup V: Protection diode life test and switching</p> <p>NOTE 2 Integrate the front and rear interconnectors to the diode.</p> <p>NOTE 3 Use a pressure contact for this group.</p>						

## 9.5.4 Integral and external protection diodes

### 9.5.4.1 Production and test schedule

- a. Before starting production of the qualification lot, the manufacturer shall compile a production test schedule showing by date and duration the production and test activities, including all major processing operations and key stages in the production and testing.
- b. A production flow chart, process schedules and inspection procedures shall be provided.

#### 9.5.4.2 Qualification test samples

- a. The diodes for qualification testing shall conform to the PID.
- b. The test samples shall be chosen statistically and at random from a minimum number of diodes, stated in the SCD-BSC or SCD-EPD, and from the first n batches, where n is also stated in the SCD-BSC or SCD-EPD.

NOTE For sampling see ISO 2859.

- c. Facilities shall be available to safely store the qualification lot including failed samples for a minimum of 6 years (equivalent to five years in storage and one year in orbit).

#### 9.5.4.3 Qualification testing

- a. The total quantity of test samples shall be a minimum in conformance with Table 9-3 (for IPD) or Table 9-4 (for EPD).
- b. The qualification tests shall be divided into subgroups of tests, and the samples assigned to a subgroup subjected to the tests in that subgroup in the sequence specified.
- c. More than one failure in any subgroup, or more than two failures in total, shall constitute a failure in the qualification.

NOTE For a definition of failure see 9.7.

## 9.6 Test methods, conditions and measurements

### 9.6.1 General

- a. The level of allowable spikes to the diode shall be agreed between the customer and supplier and included in the SCD-BSC or SCD-EPD.
- b. The test system shall be checked on compliance with 9.6.1a by using an oscilloscope and dummy cell before performing the following electrical test on diodes, 9.6.5, 9.6.14, 9.6.15, 9.6.16, 9.6.17 and 9.6.18.

NOTE The test methods, conditions and measurement requirements for the tests in Table 9-3 and Table 9-4 are detailed in clauses 9.6.2 to 9.6.18. For failure criteria, see clause 9.7.

### 9.6.2 Visual inspection (VI)

#### 9.6.2.1 Applicability

The requirements on visually observable defects defined in this clause apply to granting qualification approval to a high quality protection diode.

### 9.6.2.2 Test process

- a. Protection diodes shall be inspected by one of the following methods:
  - with an equipment with a resolution which is 5 times higher than the minimum allowed defect size for defects on protection diodes and contacts, or
  - An optical inspections method agreed with the customer.

### 9.6.2.3 Deviations

- a. Any deviation from the visual inspection requirements on defects (clauses 9.6.2.4 and 9.6.2.5) shall:
  1. not affect performance or reliability,
  2. be agreed with the customer, and
  3. be justified.

### 9.6.2.4 Protection diode defects - Cracks and fingerprints

- a. Cracks and fingerprints shall not be present.

### 9.6.2.5 External protection diode contact area defects

#### 9.6.2.5.1 General

- a. The protection diode contact area shall be free of digs, scratches, and probe prints, unless metallization is still present.
- b. Peeling, blistering and delamination of contacts shall not be present.
- c. Digs or depressions deeper than 0,025 mm shall not be present.

#### 9.6.2.5.2 N-side and P-side contact area

- a. The maximum dimension of voids or bubbles shall be 0,25 mm in diameter.
- b. The maximum dimension of drops and spatter shall be 0,25 mm in diameter and 0,05 mm in height.

### 9.6.3 Dimensions and weight (DW)

- a. The overall lateral dimensions of the protection diode (including thickness of the EPD), contact dimensions and interconnector position shall conform to the requirements stated in the SCD-BSC or SCD-EPD.
- b. The weight of the external protection diode shall
  1. be verified by determination of the average weight per qualification lot or weight per contacts vacuum evaporation batch (sample base) and
  2. conform to the requirements defined in the SCD-EPD.
- c. The weight of the integral protection diode shall be considered as part of the bare solar cell weight

## 9.6.4 Thermal cycling (CY)

### 9.6.4.1 Purpose

This test is an accelerated thermal cycling test to verify the robustness of the crystalline structure and the coating against thermal cycling.

### 9.6.4.2 Process

- a. All external protection diode qualification samples shall be submitted to thermal cycling consisting of  $TBS_c$  cycles from  $-TBS_1$  °C to  $+TBS_2$  °C under nitrogen gas environment, where the values  $TBS_c$ ,  $TBS_1$  and  $TBS_2$  are values to be specified in the SCD-EPD.
- b. Thermal cycling of internal protection diodes shall be part of the BSC thermal cycling testing.

## 9.6.5 Burn in (BI)

### 9.6.5.1 Purpose

This test is operational load test to screen for infant mortality within the qualification batch.

### 9.6.5.2 Process

- a. Each qualification sample shall be submitted to a burn-in process under ambient pressure conditions.
- b. The diode temperature shall be  $T_J = TBS$  °C as indicated in the SCD-BSC or SCD-EPD.
- c. During the process the samples shall be under load.
- d. The process shall consist of the following phases:
  1. Phase 1: 200 h reverse biased with  $V_{rev} = -1,5 \times V_{oc}$  in which  $V_{oc}$  is the open circuit voltage of the project relevant solar cell at the minimum mission temperature specified in the solar array specification.
  2. Phase 2: 16 h forward biased with  $I_{fwd} = 1,1 I_{sc}$  in which  $I_{sc}$  is the maximum solar cell short circuit current of the project relevant solar cell during the mission.

## 9.6.6 Humidity and temperature (HT)

### 9.6.6.1 Purpose

This test is an accelerated shelf life test to monitor the stability of functioning, contacts and coatings in a humid atmosphere.

### **9.6.6.2 Process**

- a. All protection diodes in subgroup O shall be placed in a chamber at ambient pressure.
- b. The chamber temperature shall then be increased to 60 °C minimum.
- c. Relative humidity shall be higher than 90 %.
- d. The duration of the test shall be 30 days.
- e. High-purity water in conformance with ASTM D1193-99, Type I, shall be used.
- f. Water condensation on the surface of the protection diodes shall be prevented.
- g. If there are requirements on specific environmental conditions, such as chemical vapours, they shall be stated in the SCD-BSC.

## **9.6.7 Contact uniformity (CU)**

### **9.6.7.1 Purpose**

The diode contact uniformity test verifies the uniformity of the thickness of the diode contacts during qualification.

The test applicable to integral protection diodes is similar to the test described in clause 7.5.9.

### **9.6.7.2 Process**

- a. The uniformity of the thickness of the metal contact in the interconnector weld area shall be checked with a with a step-height profiler for instance a betascope, or a similar instrument.

### **9.6.7.3 Pass Fail Criteria**

- a. The uniformity of the contact thickness of the metal layers of the cell contact shall conform to the requirements of the interconnection process (as stated in the SCD-EPD) and the procurement specification of the supplier.

## **9.6.8 Contact thickness (CT)**

### **9.6.8.1 Purpose**

The diode contact thickness test verifies the thickness of the diode contact during acceptance test.

The test applicable to integral protection diodes is similar to the test described in clause 7.5.10.

### **9.6.8.2 Process**

- a. The thickness of the diode metal contact in the interconnector weld area or on dedicated in-process test samples shall be checked (either with a step-height profiler for instance a betascope or similar instrument).

### **9.6.8.3 Pass Fail Criteria**

- a. The thickness of the metal layers of the diode contacts shall conform to the requirements of the interconnection process (as stated in the SCD-EPD), and the certified procurement specification of the supplier.

## **9.6.9 Surface Finish (SF)**

### **9.6.9.1 Purpose**

The diode surface finish test verifies the surface finish of the diode contacts.

The test applicable to integral protection diodes is similar to the test described in clause 7.5.11.

### **9.6.9.2 Process**

- a. The surface finish in the interconnector weld area shall be checked with a micro surface-roughness tester.

### **9.6.9.3 Pass Fail Criteria**

- a. The surface finish of the metal layers of the diode contact shall conform to the requirements of the interconnection process (as stated in the SCD-EPD), and the certified procurement specification of the supplier.

## **9.6.10 Contact adherence (CA)**

### **9.6.10.1 Purpose**

This test is performed to verify the durability of the contacts of the external protection diodes.

The test applicable to internal protection diodes is similar to the test described in clause 7.5.8.

### **9.6.10.2 Process**

- a. All diodes shall be subjected to a coating adherence test on both sample faces.
- b. Test method shall be established according to a standard which is mutually agreed with the customer.

NOTE Example of such standards are ISO 9211-4 or ECSS-Q-ST-70-13.

- c. The adhesive tape used for this test shall be clear in colour with an adhesive strength on steel of at least 0,28 N/mm.

NOTE Example of a standard that can be used to measure the strength is EN 1939.

- d. It shall be assured that the adhesion of the used tape is within a tolerance of + 10 %.
- e. Any visible delamination of parts of the contacts shall not exceed the limits specified in clause 9.6.2.5.

## 9.6.11 Pull test (PT)

### 9.6.11.1 Purpose

The objective of the pull test is to check the bond strength of the positive and negative contacts under mechanical and environmental stress.

### 9.6.11.2 Process

- a. A gradually increasing pull force shall be applied to the interconnector tabs at a pull speed as stated in the SCD-BSC or SCD-EPD.
- b. The ultimate pull strength of each tab shall be as stated in the SCD-BSC or SCD-EPD.
- c. The pull direction that either can be 0°, 45° or 90° shall be as stated in the SCD-BSC or SCD-EPD.

## 9.6.12 Electron irradiation (EI)

### 9.6.12.1 Purpose

This test is an accelerated life test to check the protection diode performance degradation under electron particle irradiation. The test described hereafter is only applied on the external protection diodes. Integral protection diodes are irradiated as part of the bare solar cell irradiation test, clause 7.5.13.

### 9.6.12.2 Process

- a. The external protection diodes shall be subjected to 1 MeV electron irradiation.

NOTE ISO 23038 outlines a methodology to perform this test.

- b. The flux density and energy shall be uniform over the cell area within ±10 %.
- c. During irradiation, the test samples shall be protected from oxidation, using either vacuum (below 10<sup>-3</sup> Pa) or a dry atmosphere of nitrogen or argon at a temperature of (20 ± 10) °C.
- d. The nominal rate shall be lower than 5 × 10<sup>11</sup> e<sup>-</sup> cm<sup>-2</sup> s<sup>-1</sup>.

- e. The irradiation facility, dosimetry included, shall be approved by the customer.
- f. The irradiation shall be performed as follows:
  - 1. State the expected dose for the envisaged application (included transfer orbit dose),  $\Phi_p$ , in the SCD-EPD.
  - 2. Divide Subgroup C (in conformance with Table 9-4) in three batches of 8 samples.
  - 3. Irradiate the batches specified in 2. as follows:
    - (a) the first batch at  $\Phi_p/2$ ;
    - (b) the second batch, at  $\Phi_p$ .
    - (c) the third batch, at  $2 \times \Phi_p$ .
- g. After electron irradiation and temperature annealing, the requirements as stated in the SCD-EPD for the diode characteristics shall be satisfied.

### **9.6.13 Temperature annealing (TA)**

#### **9.6.13.1 Purpose**

This test is to verify the stability of protection diode performance under temperature. The test described hereafter is only applied on the external protection diodes. Integral protection diodes are tested as part of the bare solar cell photon irradiation and temperature annealing test, clause 7.5.15.

#### **9.6.13.2 Process**

- a. The protection diodes shall be temperature annealed for 24 h at 60 °C
- b. After the test, the samples shall be kept at temperatures below 50 °C until the diode characterization test is performed.

### **9.6.14 Temperature behaviour (TB)**

#### **9.6.14.1 Purpose**

The purpose of this test is to assess the corresponding electrical parameters of the protection diodes as a function of temperature over the entire temperature range of the application and to provide data for the design of the solar generator.

#### **9.6.14.2 Process**

- a. Temperature behaviour of all samples in subgroup C shall be measured.
- b. The diode characterization described in clause 9.6.15 shall be measured, as a minimum,
  - 1. at three temperatures:  $T_J = 25$  °C, 80 °C and 150 °C.



2. For mission specific qualification, at three protection diode temperatures: the two temperature extremes  $t_1$  and  $t_2$  and the operational temperature.
  - $t_1$  = highest operation diode temperature (without margins) predicted for the mission + 25 °C
  - $t_2$  = lowest operation diode temperature (without margins) predicted for the mission.

## 9.6.15 Diode characterization (DC)

### 9.6.15.1 Purpose

The purpose of diode characterization tests is to monitor the performance before, for example, environmental tests, and to subsequently check for performance degradation after these tests. In addition the test is to provide data for array level design.

### 9.6.15.2 Process

- a. The test under illumination shall be performed at 1 S.C. (AM0).
- b. The forward and reverse I/V characteristic of the diode shall be recorded:
  1. in darkness
  2. under illumination, unless it is demonstrated that the protection diode has a negligible photovoltaic response.
  3. with a limiting power supply (to avoid destructive breakdown), and
  4. with temperature control imposed (to avoid thermal runaway),
- c. Provision 9.6.15.2b shall be performed for the following variables, as stated in the SCD-BSC or SCD-EPD:
  1. At different temperatures (including maximum and minimum operating temperature with margins and sustained operation in forward bias).
  2. For different times.
  3. Up to a forward current,  $I_{\text{DIODE-FORWARD}}$ , which is as a minimum, equal to 1,1 times the expected string current at solar array level at the maximum mission temperature specified in the solar array specification.
  4. Up to a reverse voltage,  $V_{\text{DIODE-REVERSE}}$ , which is as a minimum, equal to n times the expected solar cell open circuit voltage at the minimum mission temperature specified in the solar array specification, being
    - (a)  $n=1,33$  for acceptance testing and
    - (b)  $n=1,5$  for qualification testing)

- d. The increase of temperature in forward mode at maximum operating temperature shall be assessed in order to avoid overheating of the diode.
- e. In case of an integral protection diode the electrical isolation of cell and diode shall be tested by measuring the current when a voltage (as stated in the SCD-BSC) is applied between the front contacts of the protection diode and of the cell at the temperatures as stated in the SCD-BSC.

### **9.6.15.3 Pass-fail criteria**

- a. The diode characteristics test shall satisfy the pass-fail criteria stated in the SCD-BSC or SCD-EPD.

## **9.6.16 Human body ESD (DE)**

### **9.6.16.1 Purpose**

The purpose of this test is to determine the robustness of the protection diode against human body electrostatic discharges.

### **9.6.16.2 Process**

- a. The protection diodes shall be equipped with interconnects.
- b. The diodes shall be in flight like configuration which means connected to the adjacent cell.
- c. The test shall be performed in conformance with IEC 60749-26:2006.
- d. The voltage level shall be 12 kV for single and multi-pulse testing.
- e. Solar cell performance shall be verified in between tests.
- f. Diode characterization shall be performed at the end of the sequence of pulses, after disconnection of the diode from the cell.

### **9.6.16.3 Pass-fail criteria**

- a. The cell electrical characteristics shall satisfy the pass-fail criteria stated in the SCD-BSC.
- b. The diode electrical characteristics test shall satisfy the pass-fail criteria stated in the SCD-BSC or SCD-EPD.

## **9.6.17 Switching test (DS)**

### **9.6.17.1 Purpose**

The purpose of this test is to determine the robustness of the protection diode against the transients which it can be subjected to during the ground life and in-orbit. Transients can result from three different categories of events

- ground handling and testing:
  - mating and demating

- repair activities
- solar array performance measurements (flasher and interface compatibility with light conversion tests)
- electrical health checks (continuity, insulation, by-pass diode function)
- in-orbit electrostatic discharges, in particular primary discharges
- Switching mode transients due to power subsystem commutations

### 9.6.17.2 Process

- a. The protection diodes shall be equipped with interconnects.
- b. The number of switching cycles per category shall be at least 100.
- c. One switching cycle shall be defined as a vice-versa cycle between the reverse bias and forward bias points as defined in the Figure 9-1.
- d. The applied signal for the switching cycles shall be in conformance with the Figure 9-2.
- e. The three different categories as defined in clause 9.6.17 shall be represented by two different parameter settings ( $V_{REV}$ ,  $I_{FW}$ ,  $T_1$ ,  $T_2$  and  $T_3$ ) for the applied signal.
- f. The test parameters for the two different modes shall be defined as follows:
  1. switching level 1 ( to cover ground testing and bus commutations)
    - (a) For  $I_{FW}$ ,  $I_{REV}$ ,  $T_1$ ,  $T_2$  and  $T_3$ :
      - The following default values, if they cover the transient of the switching regulator:  
 $V_{REV} = 1,5 \times V_{oc}$  (where  $V_{oc}$  is the open circuit voltage of the solar cell connected in parallel to a protection diode as per minimum mission temperature specified in the solar array specification, in accordance with SCD-BSC or SCD-EPD)  
 $I_{FW} = 1,1 \times I_{sc}$  (where  $I_{sc}$  is the short circuit current of the solar cell connected in parallel to a protection diode as per maximum mission temperature specified in the solar array specification, in accordance with SCD-BSC or SCD-EPD)  
 $T_1 = 1 \mu s$   
 $T_2 = 50 \mu s$   
 $T_3 =$  Recommended value of 1s.
      - The values stated in the SCD-BSC or SCD-EPD, otherwise.
    - (b) For the temperature, the most extreme between the following values:
      - The values stated in the SCD-BSC or SCD-EPD.

- The highest and minimum operational temperatures with the margins predicted for the mission.
2. switching level 2 (to cover primary discharges):
- (a) For  $I_{FW}$ ,  $I_{REV}$ ,  $T_1$ ,  $T_2$  and  $T_3$ , the values stated in the SCD-BSC or SCD-EPD.

NOTE Typical test conditions defined for specific LEO mission (solar array size dependent) are  $V_{REV} = -5,3$  V,  $I_{FW} = 4,5$  A,  $T_1 = 50$   $\mu$ s,  $T_2 = 180$   $\mu$ s and  $T_3 > 1$  s.

- (b) For the temperature, the most extreme between the following values:
- The values stated in the SCD-BSC or SCD-EPD.
  - The highest and minimum operational temperatures with the margins predicted for the mission.

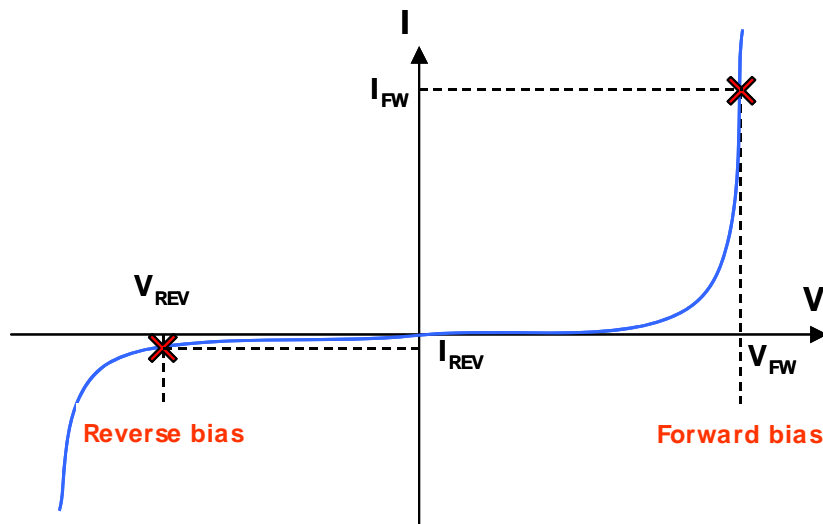
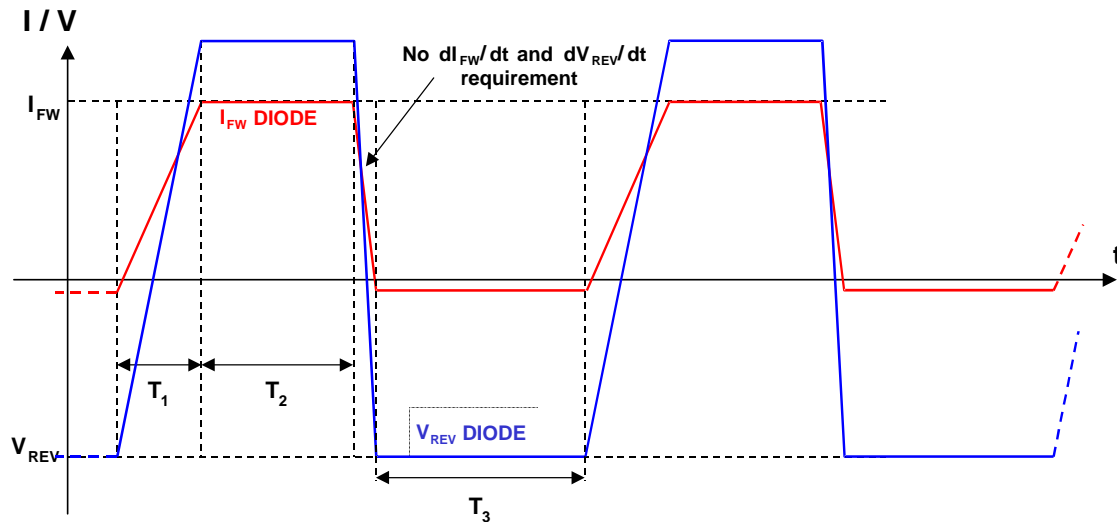

Figure 9-1: Diode forward and reverse test profile



NOTE 1: Switching time from VREV to IFWD in less than  $T_1$ .

NOTE 2: IFWD applied for a minimum of  $T_2$ .

NOTE 3: No specific requirement to the slope between forward mode and reverse bias, but recommended same order of magnitude of  $T_1$ .

NOTE 4: VREV applied for a minimum of  $T_3$

**Figure 9-2: Diode switching test profile**

### 9.6.17.3 Pass-fail criteria

- a. The diode characteristics test shall satisfy the pass-fail criteria stated in the SCD-BSC or SCD-EPD.

## 9.6.18 Life test (DL)

### 9.6.18.1 Purpose

The purpose of this test is to determine the stability of the protection diodes under worst case operation for long duration.

### 9.6.18.2 Process

- a. The protection diodes shall be equipped with interconnects
- b. The life test shall always be preceded by a burn-in test as described in clause 9.6.6.
- c. The duration of the life test shall be in conformance with the duration of the mission.
- d. The long duration test shall be performed at the temperature minimum of the following two values:
  1. The maximum allowable temperature of the diode.
  2. The temperature corresponding to the acceleration factor applied, calculated as follows:
    - (a) Determine the activation energy  $E_a$  corresponding to a predefined level of degradation.

NOTE The activation energy can be determined experimentally by measuring  $\tau$  at various temperatures above the aimed temperature or by comparison with literature data of similar degradation processes.

(b) Extrapolate the test temperature by using the expression:

$$\tau(T) \sim A \exp(E_a/k_B T)$$

Where:

$\tau(T)$  = time to reach a predefined level of degradation at temperature T,

A = constant

$E_a$  = activation energy corresponding to a predefined level of degradation,

$k_B$  = Boltzman constant

e. The test duration and parameter settings for each individual diode shall be as in Table 9-5 and mission requirements.

**Table 9-5: Diode life test parameters**

Test	Duration	Parameter	Requirements
Reverse Bias (first step)	>200 h <sup>(a)</sup>	$V_{REV}$	$I_{REV} \leq TBD^{(d)}$ mA
Forward Bias	6 h <sup>(a)</sup>	$I_{FW}$	$V_{FW} @ I_{FW} < TBD^{(d)}$ V
...			
Reverse Bias (Last step)	>200 h <sup>(a)</sup>	$V_{REV}$	$I_{REV} \leq TBD^{(d)}$ mA Stability during step <sup>(c)</sup> : $(I_{REV\ max} - I_{REV\ min}) / I_{REV\ avg} \leq 10\%$ of $I_{REV\ avg}$ or $10\mu A$ whatever is higher <sup>(b)</sup>
(a) The total number and duration of reverse bias and forward bias test steps is determined in the SCD-BSC or SCD-EPD. (b) $I_{REV\ max}$ and $I_{REV\ min}$ are the maximum and minimum reverse diode current values recorded on the last 20 % of the last test step. $I_{REV\ avg}$ is $(I_{REV\ max} + I_{REV\ min}) / 2$ (c) Stability requirement is applicable for the last 20 % of the test duration and only if the following conditions are fulfilled: reverse current is higher than 50 % of maximum allowed $I_{rev}$ and $I_{rev, min} > TBD^{(d)}$ . (d) To be determined by the supplier and specified in the SCD-BSC or SCD-IPD			

### 9.6.18.3 Pass-fail criteria

a. The diode characteristics test shall satisfy the pass-fail criteria stated in the SCD-BSC or SCD-EPD related to  $I_{REV}$ ,  $V_{FW}$  at  $I_{FW}$ .

## 9.7 Failure definition

### 9.7.1 Failure criteria

- a. The following shall constitute failures:
  - 1. Components that fail during subgroup tests for which the pass-fail criteria are inherent in the test method.
  - 2. Components failing to conform to the requirements of visual inspection stated in the SCD-BSC or SCD-EPD.
  - 3. Components whose marking fails to conform to the requirements of clause 9.2.3.
  - 4. Components that, when subjected to diode characteristics measurements after acceptance tests in conformance with the SCD-BSC or SCD-EPD, fail to meet one or more of the specified limits, measurement accuracy included.

### 9.7.2 Failed components

- a. A component shall be considered to have failed if it exhibits one or more of the failure modes specified in clause 9.7.1.
- b. Failed components shall be identified as such and included in the delivery.
- c. Failure analysis of these components shall be performed by the supplier and the results provided to the customer as part of the NRB documentation.

NOTE For NRB, see ECSS-Q-ST-10-09.

## 9.8 Data documentation

- a. The supplier shall provide a data documentation package (DDP) in conformance with Annex G for the qualification approval records and for each component delivery lot.

## 9.9 Delivery

- a. All deliverable hardware specified in the order shall be delivered together with documentation in conformance with the requirements specified in clause 9.8.
- b. One set of documents shall be sent to the customer.

## **9.10 Packing, despatching, handling and storage**

### **9.10.1 Overview**

For packaging, despatching, handling and storage of components see ESA-PSS-01-202.

### **9.10.2 ESD sensitivity**

- a. If a protection diode is sensitive to ESD according to clause 5.2 of ESCC 23800 Issue 1 then it shall be handled and stored according to ESCC 24900 Issue 2, clause 10.



# 10

## Sun simulators and calibration procedures

---

### 10.1 Sun simulators

#### 10.1.1 Spectral distribution

##### 10.1.1.1 AM0 spectrum

- a. The AM0 reference solar spectral irradiance distribution shall be in conformance with Table 10-1.

NOTE 1 This is total distribution sunlight, corresponding to an irradiance of 136,7 mW/cm<sup>2</sup> (solar constant) at AM0, on a plane surface tilted at 90° to the horizontal.

NOTE 2 This table is based on the compilation of Christoph Wehrli, of the Physikalisch-Meteorologisches Observatorium / World Radiation Center, and is compatible with ISO 15387.

##### 10.1.1.2 Total Irradiance of the Sun simulator

- a. Total Irradiance (solar constant AM0-equivalent) of the Sun simulator on the test plane shall be determined by the use of AM0 calibrated reference cells as indicated in clause 10.2.

##### 10.1.1.3 Spectral distribution of the Sun simulator

- a. The spectral distribution of the Sun simulator light incident on the test plane normalized for 0,35 μm to 1,9 μm compared to the AM0 spectrum for the spectral regions of interest shall meet one of the classes defined in Table 10-2.
- b. Percent of Total Irradiance between 0,35 μm and 1,1 μm of AM0 spectrum within various wavelength intervals defined in Table 10-2 shall be applied for Silicon and GaAs single junction solar cells.

**Table 10-1: AM0 solar spectral irradiance (WRC)**

$\lambda$ [nm]	$E_\lambda$ [W/m <sup>2</sup> /nm]	$\lambda$ [nm]	$E_\lambda$ [W/m <sup>2</sup> /nm]	$\lambda$ [nm]	$E_\lambda$ [W/m <sup>2</sup> /nm]	$\lambda$ [nm]	$E_\lambda$ [W/m <sup>2</sup> /nm]
199.5	0.005	245.5	0.051	291.5	0.600	320.8	0.844
200.5	0.007	246.5	0.051	292.5	0.545	321.2	0.847
201.5	0.007	247.5	0.057	293.5	0.545	321.6	0.736
202.5	0.008	248.5	0.045	294.5	0.509	322	0.695
203.5	0.009	249.5	0.058	295.5	0.548	322.4	0.773
204.5	0.009	250.5	0.059	296.5	0.492	322.8	0.758
205.5	0.010	251.5	0.047	297.5	0.531	323.2	0.646
206.5	0.010	252.5	0.044	298.5	0.413	323.6	0.603
207.5	0.011	253.5	0.055	299.5	0.485	324	0.604
208.5	0.015	254.5	0.061	300.5	0.403	324.4	0.618
209.5	0.024	255.5	0.089	301.5	0.445	324.8	0.654
210.5	0.028	256.5	0.107	302.5	0.484	325.2	0.646
211.5	0.034	257.5	0.129	303.5	0.631	325.6	0.682
212.5	0.030	258.5	0.134	304.5	0.610	326	0.852
213.5	0.032	259.5	0.108	305.5	0.580	326.4	1.049
214.5	0.041	260.5	0.102	306.5	0.575	326.8	1.111
215.5	0.037	261.5	0.103	307.5	0.645	327.2	1.108
216.5	0.034	262.5	0.121	308.5	0.613	327.6	1.050
217.5	0.036	263.5	0.175	309.5	0.484	328	0.965
218.5	0.045	264.5	0.274	310	0.495	328.4	0.914
219.5	0.048	265.5	0.280	310.4	0.507	328.8	0.913
220.5	0.048	266.5	0.260	310.8	0.588	329.2	0.952
221.5	0.039	267.5	0.270	311.2	0.707	329.6	1.043
222.5	0.051	268.5	0.260	311.6	0.747	330	1.144
223.5	0.066	269.5	0.252	312	0.707	330.4	1.137
224.5	0.058	270.5	0.293	312.4	0.644	330.5	1.006
225.5	0.054	271.5	0.232	312.8	0.663	331.5	0.968
226.5	0.041	272.5	0.215	313.2	0.710	332.5	0.921
227.5	0.041	273.5	0.204	313.6	0.691	333.5	0.905
228.5	0.054	274.5	0.137	314	0.689	334.5	0.940
229.5	0.048	275.5	0.200	314.4	0.722	335.5	0.982
230.5	0.056	276.5	0.258	314.8	0.673	336.5	0.765
231.5	0.050	277.5	0.240	315.2	0.695	337.5	0.866
232.5	0.055	278.5	0.166	315.6	0.765	338.5	0.916
233.5	0.046	279.5	0.089	316	0.675	339.5	0.937
234.5	0.039	280.5	0.112	316.4	0.569	340.5	0.992
235.5	0.057	281.5	0.231	316.8	0.623	341.5	0.936
236.5	0.049	282.5	0.307	317.2	0.749	342.5	0.995
237.5	0.053	283.5	0.330	317.6	0.830	343.5	0.985
238.5	0.042	284.5	0.244	318	0.813	344.5	0.719
239.5	0.046	285.5	0.141	318.4	0.673	345.5	0.967
240.5	0.043	286.5	0.320	318.8	0.642	346.5	0.919
241.5	0.052	287.5	0.371	319.2	0.768	347.5	0.902
242.5	0.072	288.5	0.307	319.6	0.759	348.5	0.948
243.5	0.065	289.5	0.456	320	0.712	349.5	0.865
244.5	0.062	290.5	0.623	320.4	0.778	350.5	1.119

**Table 10-1: AM0 solar spectral irradiance (WRC) (continued)**

$\lambda$ [nm]	$E_\lambda$ [W/m <sup>2</sup> /nm]	$\lambda$ [nm]	$E_\lambda$ [W/m <sup>2</sup> /nm]	$\lambda$ [nm]	$E_\lambda$ [W/m <sup>2</sup> /nm]	$\lambda$ [nm]	$E_\lambda$ [W/m <sup>2</sup> /nm]
351.5	0.993	397.5	1.040	443.5	1.911	489.5	1.962
352.5	0.871	398.5	1.538	444.5	1.975	490.5	2.009
353.5	1.115	399.5	1.655	445.5	1.823	491.5	1.898
354.5	1.133	400.5	1.649	446.5	1.893	492.5	1.898
355.5	1.058	401.5	1.796	447.5	2.079	493.5	1.890
356.5	0.938	402.5	1.803	448.5	1.975	494.5	2.060
357.5	0.891	403.5	1.658	449.5	2.029	495.5	1.928
358.5	0.627	404.5	1.602	450.5	2.146	496.5	2.019
359.5	1.136	405.5	1.672	451.5	2.111	497.5	2.020
360.5	0.979	406.5	1.624	452.5	1.943	498.5	1.868
361.5	0.894	407.5	1.545	453.5	1.972	499.5	1.972
362.5	1.175	408.5	1.824	454.5	1.981	500.5	1.859
363.5	0.958	409.5	1.706	455.5	2.036	501.5	1.814
364.5	1.015	410.5	1.502	456.5	2.079	502.5	1.896
365.5	1.263	411.5	1.819	457.5	2.102	503.5	1.936
366.5	1.249	412.5	1.791	458.5	1.973	504.5	1.871
367.5	1.214	413.5	1.758	459.5	2.011	505.5	1.995
368.5	1.088	414.5	1.739	460.5	2.042	506.5	1.963
369.5	1.331	415.5	1.736	461.5	2.057	507.5	1.908
370.5	1.075	416.5	1.844	462.5	2.106	508.5	1.921
371.5	1.307	417.5	1.667	463.5	2.042	509.5	1.918
372.5	1.065	418.5	1.686	464.5	1.978	510.5	1.949
373.5	0.838	419.5	1.703	465.5	2.044	511.5	1.999
374.5	0.878	420.5	1.760	466.5	1.923	512.5	1.869
375.5	1.141	421.5	1.799	467.5	2.017	513.5	1.863
376.5	1.101	422.5	1.584	468.5	1.996	514.5	1.876
377.5	1.291	423.5	1.713	469.5	1.992	515.5	1.902
378.5	1.341	424.5	1.770	470.5	1.879	516.5	1.671
379.5	1.000	425.5	1.697	471.5	2.020	517.5	1.728
380.5	1.289	426.5	1.700	472.5	2.043	518.5	1.656
381.5	1.096	427.5	1.571	473.5	1.993	519.5	1.830
382.5	0.733	428.5	1.589	474.5	2.053	520.5	1.833
383.5	0.684	429.5	1.477	475.5	2.018	521.5	1.908
384.5	1.027	430.5	1.136	476.5	1.958	522.5	1.825
385.5	0.954	431.5	1.688	477.5	2.077	523.5	1.896
386.5	1.071	432.5	1.648	478.5	2.011	524.5	1.960
387.5	0.966	433.5	1.733	479.5	2.078	525.5	1.932
388.5	0.912	434.5	1.672	480.5	2.037	526.5	1.676
389.5	1.227	435.5	1.725	481.5	2.092	527.5	1.830
390.5	1.223	436.5	1.931	482.5	2.025	528.5	1.899
391.5	1.398	437.5	1.808	483.5	2.021	529.5	1.920
392.5	0.955	438.5	1.569	484.5	1.971	530.5	1.954
393.5	0.489	439.5	1.827	485.5	1.832	531.5	1.965
394.5	1.101	440.5	1.715	486.5	1.627	532.5	1.773
395.5	1.378	441.5	1.933	487.5	1.832	533.5	1.925
396.5	0.650	442.5	1.982	488.5	1.916	534.5	1.860

**Table 10-1: AM0 solar spectral irradiance (WRC) (continued)**

$\lambda$ [nm]	$E_\lambda$ [W/m <sup>2</sup> /nm]	$\lambda$ [nm]	$E_\lambda$ [W/m <sup>2</sup> /nm]	$\lambda$ [nm]	$E_\lambda$ [W/m <sup>2</sup> /nm]	$\lambda$ [nm]	$E_\lambda$ [W/m <sup>2</sup> /nm]
535.5	1.992	581.5	1.855	627.5	1.699	717	1.355
536.5	1.873	582.5	1.875	628.5	1.699	719	1.329
537.5	1.884	583.5	1.859	629.5	1.679	721	1.332
538.5	1.906	584.5	1.862	631	1.641	723	1.349
539.5	1.834	585.5	1.786	633	1.653	725.9	1.351
540.5	1.772	586.5	1.832	635	1.658	727	1.347
541.5	1.883	587.5	1.850	637	1.656	729	1.320
542.5	1.827	588.5	1.752	639	1.653	731	1.327
543.5	1.881	589.5	1.614	641	1.616	733	1.319
544.5	1.881	590.5	1.815	643	1.623	735.9	1.310
545.5	1.903	591.5	1.789	645	1.629	737	1.308
546.5	1.881	592.5	1.810	647	1.605	739	1.279
547.5	1.835	593.5	1.798	649	1.560	741	1.259
548.5	1.865	594.5	1.776	651	1.608	743	1.287
549.5	1.897	595.5	1.785	653	1.601	745	1.280
550.5	1.864	596.5	1.807	655	1.534	747	1.284
551.5	1.873	597.5	1.783	657	1.386	749	1.271
552.5	1.848	598.5	1.760	659	1.551	751	1.263
553.5	1.884	599.5	1.777	661	1.573	753	1.260
554.5	1.900	600.5	1.748	663	1.557	755	1.256
555.5	1.899	601.5	1.753	665	1.562	757	1.249
556.5	1.823	602.5	1.721	667	1.537	759	1.241
557.5	1.848	603.5	1.789	669	1.548	761	1.238
558.5	1.789	604.5	1.779	671	1.518	763	1.242
559.5	1.810	605.5	1.766	673	1.523	765	1.222
560.5	1.845	606.5	1.762	675	1.512	767	1.186
561.5	1.826	607.5	1.760	677	1.510	769	1.204
562.5	1.852	608.5	1.745	679	1.500	771	1.205
563.5	1.863	609.5	1.746	681	1.494	773	1.209
564.5	1.856	610.5	1.705	683	1.481	775	1.189
565.5	1.800	611.5	1.748	685.9	1.457	777	1.197
566.5	1.831	612.5	1.707	687	1.469	779	1.188
567.5	1.889	613.5	1.685	689	1.463	781	1.188
568.5	1.812	614.5	1.715	691	1.450	783	1.177
569.5	1.862	615.5	1.715	693	1.450	785	1.181
570.5	1.772	616.5	1.611	695.9	1.438	787	1.178
571.5	1.825	617.5	1.709	697	1.418	789	1.175
572.5	1.894	618.5	1.726	699	1.427	791	1.159
573.5	1.878	619.5	1.709	701	1.388	793	1.144
574.5	1.869	620.5	1.736	703	1.390	795	1.135
575.5	1.832	621.5	1.692	705.9	1.417	797	1.153
576.5	1.848	622.5	1.715	707	1.402	799	1.136
577.5	1.859	623.5	1.668	709	1.386	801	1.143
578.5	1.786	624.5	1.658	711	1.387	803	1.130
579.5	1.830	625.5	1.634	713	1.375	805.9	1.116
580.5	1.840	626.5	1.699	715.9	1.368	807	1.121

**Table 10-1: AM0 solar spectral irradiance (WRC) (continued)**

$\lambda$ [nm]	$E_\lambda$ [W/m <sup>2</sup> /nm]	$\lambda$ [nm]	$E_\lambda$ [W/m <sup>2</sup> /nm]	$\lambda$ [nm]	$E_\lambda$ [W/m <sup>2</sup> /nm]	$\lambda$ [nm]	$E_\lambda$ [W/m <sup>2</sup> /nm]
809	1.096	901	0.905	993	0.755	1212.5	0.489
811	1.115	903	0.905	995.9	0.756	1217.5	0.500
813	1.116	905	0.893	997	0.743	1222.5	0.481
815.9	1.108	907	0.891	999	0.743	1227.5	0.481
817	1.105	909	0.861	1002.5	0.745	1232.5	0.484
819	1.065	911	0.870	1007.5	0.737	1237.5	0.477
821	1.081	913	0.876	1012.5	0.734	1242.5	0.477
823	1.074	915	0.866	1017.5	0.721	1247.5	0.466
825.9	1.076	917	0.859	1022.5	0.704	1252.5	0.474
827	1.077	919	0.858	1027.5	0.708	1257.5	0.463
829	1.073	921	0.830	1032.5	0.688	1262.5	0.444
831	1.069	923	0.821	1037.5	0.692	1267.5	0.438
833	1.034	925	0.825	1042.5	0.681	1272.5	0.439
835.9	1.053	927	0.828	1047.5	0.685	1277.5	0.453
837	1.052	929	0.833	1052.5	0.661	1282.5	0.435
839	1.042	931	0.826	1057.5	0.650	1287.5	0.437
841	1.045	933	0.832	1062.5	0.642	1292.5	0.442
843	1.028	935.9	0.818	1067.5	0.643	1297.5	0.438
845.9	1.033	937	0.802	1072.5	0.638	1302.5	0.438
847	1.025	939	0.808	1077.5	0.630	1307.5	0.429
849	0.971	941	0.800	1082.5	0.620	1312.5	0.419
851	1.003	943	0.784	1087.5	0.614	1317.5	0.416
853	0.973	945.9	0.799	1092.5	0.612	1322.5	0.416
855.9	0.877	947	0.793	1097.5	0.599	1327.5	0.411
857	1.011	949	0.777	1102.5	0.608	1332.5	0.405
859	0.997	951	0.778	1107.5	0.601	1337.5	0.400
861	0.997	953	0.771	1112.5	0.603	1342.5	0.398
863	0.999	955.9	0.760	1117.5	0.589	1347.5	0.394
865.9	0.970	957	0.774	1122.5	0.579	1352.5	0.387
867	0.880	959	0.771	1127.5	0.569	1357.5	0.382
869	0.967	961	0.767	1132.5	0.566	1362.5	0.378
871	0.986	963	0.767	1137.5	0.563	1367.5	0.370
873	0.978	965.9	0.764	1142.5	0.557	1372.5	0.369
875.9	0.981	967	0.757	1147.5	0.556	1377.5	0.368
877	0.984	969	0.776	1152.5	0.545	1382.5	0.364
879	0.959	971	0.763	1157.5	0.554	1387.5	0.364
881	0.960	973	0.764	1162.5	0.540	1392.5	0.358
883	0.948	975.9	0.750	1167.5	0.530	1397.5	0.357
885	0.963	977	0.768	1172.5	0.533	1402.5	0.353
887	0.947	979	0.768	1177.5	0.525	1407.5	0.350
889	0.949	981	0.762	1182.5	0.514	1412.5	0.346
891	0.944	983	0.766	1187.5	0.512	1417.5	0.344
893	0.934	985.9	0.771	1192.5	0.511	1422.5	0.343
895	0.936	987	0.756	1197.5	0.502	1427.5	0.348
897	0.939	989	0.767	1202.5	0.496	1432.5	0.337
899	0.912	991	0.764	1207.5	0.494	1437.5	0.331

**Table 10-1: AM0 solar spectral irradiance (WRC) (continued)**

$\lambda$ [nm]	$E_\lambda$ [W/m <sup>2</sup> /nm]	$\lambda$ [nm]	$E_\lambda$ [W/m <sup>2</sup> /nm]	$\lambda$ [nm]	$E_\lambda$ [W/m <sup>2</sup> /nm]	$\lambda$ [nm]	$E_\lambda$ [W/m <sup>2</sup> /nm]
1442.5	0.327	1672.5	0.228	1902.5	0.133	2402.5	0.054
1447.5	0.318	1677.5	0.220	1907.5	0.136	2422.5	0.057
1452.5	0.323	1682.5	0.221	1912.5	0.138	2442.5	0.051
1457.5	0.307	1687.5	0.219	1917.5	0.136	2467.5	0.053
1462.5	0.317	1692.5	0.219	1922.5	0.134	2492.5	0.054
1467.5	0.311	1697.5	0.214	1927.5	0.132	2517.5	0.047
1472.5	0.311	1702.5	0.217	1932.5	0.132	2542.5	0.046
1477.5	0.307	1707.5	0.212	1937.5	0.131	2567.5	0.044
1482.5	0.303	1712.5	0.203	1942.5	0.129	2592.5	0.042
1487.5	0.298	1717.5	0.212	1947.5	0.127	2617.5	0.041
1492.5	0.303	1722.5	0.205	1952.5	0.126	2642.5	0.039
1497.5	0.300	1727.5	0.196	1957.5	0.122	2672.5	0.038
1502.5	0.296	1732.5	0.190	1962.5	0.126	2702.5	0.036
1507.5	0.295	1737.5	0.189	1967.5	0.125	2732.5	0.035
1512.5	0.290	1742.5	0.191	1972.5	0.125	2762.5	0.034
1517.5	0.290	1747.5	0.185	1977.5	0.129	2797.5	0.032
1522.5	0.286	1752.5	0.187	1982.5	0.125	2832.5	0.031
1527.5	0.290	1757.5	0.189	1987.5	0.123	2867.5	0.029
1532.5	0.282	1762.5	0.184	1992.5	0.121	2907.5	0.028
1537.5	0.274	1767.5	0.182	1997.5	0.123	2947.5	0.026
1542.5	0.275	1772.5	0.177	2002.5	0.116	2987.5	0.025
1547.5	0.274	1777.5	0.173	2012.5	0.114	3025	0.024
1552.5	0.273	1782.5	0.171	2022.5	0.113	3075	0.023
1557.5	0.272	1787.5	0.170	2032.5	0.110	3125	0.021
1562.5	0.269	1792.5	0.169	2042.5	0.107	3175	0.020
1567.5	0.263	1797.5	0.173	2052.5	0.104	3235	0.019
1572.5	0.260	1802.5	0.169	2062.5	0.100	3295	0.018
1577.5	0.259	1807.5	0.168	2077.5	0.101	3355	0.016
1582.5	0.255	1812.5	0.160	2092.5	0.098	3425	0.015
1587.5	0.252	1817.5	0.160	2107.5	0.093	3495	0.014
1592.5	0.246	1822.5	0.159	2122.5	0.087	3575	0.013
1597.5	0.246	1827.5	0.156	2137.5	0.085	3665	0.012
1602.5	0.247	1832.5	0.156	2152.5	0.081	3755	0.011
1607.5	0.242	1837.5	0.150	2167.5	0.080	3855	0.010
1612.5	0.244	1842.5	0.153	2182.5	0.075	3965	0.009
1617.5	0.243	1847.5	0.151	2197.5	0.073	4085	0.008
1622.5	0.240	1852.5	0.148	2212.5	0.075	4225	0.007
1627.5	0.244	1857.5	0.145	2227.5	0.075	4385	0.006
1632.5	0.241	1862.5	0.143	2247.5	0.072	4575	0.005
1637.5	0.237	1867.5	0.143	2262.5	0.071	4805	0.004
1642.5	0.234	1872.5	0.135	2282.5	0.069	5085	0.003
1647.5	0.235	1877.5	0.135	2302.5	0.066	5445	0.002
1652.5	0.234	1882.5	0.140	2322.5	0.053	5925	0.002
1657.5	0.234	1887.5	0.138	2342.5	0.058	6615	0.001
1662.5	0.233	1892.5	0.137	2362.5	0.065	7785	0.001
1667.5	0.229	1897.5	0.138	2382.5	0.055	10075	0.000

**Table 10-2: Classes of single and multi-source solar simulators**

Wavelength Interval [μm]	Percent of Total Irradiance for between indicated Total Range of AM0 spectrum within various wavelength intervals		Bins [μm]	Class A	Class B	Class C
	Total Range 0,35 and 1,9 μm (121,74 mW/cm <sup>2</sup> )	Total Range 0,35 and 1,1 μm (95,98 mW/cm <sup>2</sup> )				
0,35 - 0,4	4,4	5,6	0,15	±15 %	±20 %	±25 %
0,4 - 0,5	15,3	19,4				
0,5 - 0,6	15,2	19,3	0,1	±15 %	±20 %	±25 %
0,6 - 0,7	13,1	16,6				
0,7 - 0,8	10,4	13,2				
0,8 - 0,9	8,4	10,6				
0,9 - 1,0	6,6	8,3				
1,0 - 1,1	5,5	7,0				
1,1 - 1,2	4,5					
1,2 - 1,3	3,8					
1,3 - 1,4	3,2					
1,4 - 1,5	2,7					
1,5 - 1,6	2,2					
1,6 - 1,7	1,9					
1,7 - 1,8	1,6					
1,8 - 1,9	1,2					

c. The following method shall be used to verify spectral distribution of irradiance performance:

1. Apply one of the following methods:
  - Direct measurement with a calibrated spectro-radiometer.
  - Measurement with a two-channel spectro-radiometer against a calibrated reference light source.
2. Calculate the deviation of the total energy per spectral region with reference to the AM0 spectrum using the following expression:

$$Dev_{REL}(E(\lambda)_{SIM}) = \frac{\left[ \int_{Range} E(\lambda)_{SIM} d\lambda \right] / \left[ \int_{Total} E(\lambda)_{SIM} d\lambda \right] - \left[ \int_{Range} E(\lambda)_{AM0} d\lambda \right] / \left[ \int_{Total} E(\lambda)_{AM0} d\lambda \right]}{\left[ \int_{Range} E(\lambda)_{AM0} d\lambda \right] / \left[ \int_{Total} E(\lambda)_{AM0} d\lambda \right]}$$

where

$E(\lambda)_{SIM}$  is the spectral irradiance of the solar simulator;

$E(\lambda)_{AM0}$  is the AM0 spectral irradiance;

*Range* is the spectral region of interest.

- d. For a test lot of single solar cells, the spectral distribution of the Sun simulator in the test plane shall be matched to the AM0 spectrum for errors due to the spectral response spread of the relevant lot of cells to be 1 % or less, as follows:
  1. Measure the short-circuit current of 10 solar cells accepted by the customer as representing a worst-case simulation of the spectral response spread of the cells to be tested, at the constant nominal intensity of the Sun simulator.
  2. From the measured spectral response of the cells (in conformance with clause 7.5.5) and the AM0 spectrum given in Table 10-1:
    - (a) Calculate the short-circuit current and multiply it by a common factor which adjusts the average calculated short-circuit current to the average current resulting from the simulator measurements.
    - (b) Ensure that the difference between the calculated and measured current of each individual cell does not exceed 1 % of the measured current.
- e. For a test lot of multijunction solar cells, the spectral distribution of the Sun simulator in the test plane shall be matched to the AM0 spectrum for errors due to the spectral response spread of the relevant lot of cells to be 1 % or less, as follows:
  1. Adjust the irradiance in the test plane to AM0 equivalent conditions using component reference cells
  2. Measure the spectral distribution of the Sun simulator following one of the methods given in 10.1.1.2a.
  3. Measure the spectral response of 10 solar cells accepted by the customer as representing a worst-case simulation of the spectral response spread of the cells to be tested, according to clause 7.5.5.
  4. From the measured spectral responses of the cells and the component reference cell, the spectral distribution of the Sun simulator and the AM0 spectrum given in Table 10-1:
    - (a) Calculate the spectral mismatch parameter for each junction.
    - (b) Ensure that the effective irradiance (i.e. short-circuit output under the Sun simulator divided by AM0 calibrated value) for each component reference cell multiply by the corresponding individual spectral mismatch parameter is  $1,00 \pm 0,01$ .



### 10.1.2 Irradiance uniformity

- a. The uniformity of the irradiance, as defined in requirement 10.1.2e, in the test plane over the full extent of the nominated test area, shall meet one of the classes of solar simulators in Table 10-3.
- b. For multi-source simulators used for characterizing multijunction solar cells, the relevant class of solar simulator in Table 10-3 shall be determined for each junction.
- c. For bare solar cells and SCAs, testing, the largest dimension of the detector shall be less than half of the smallest dimensions of the cell, with a minimum dimension of 1 cm for rectangular detector, or a minimum area of 1cm<sup>2</sup> for circular detector.
- d. In the case of coupons, the detector shall not be bigger than the SCAs bonded to it.
- e. The nonconformity in the uniformity of the irradiance shall be calculated as follows:

$$\text{Nonconformity (\%)} = 100 \times (MI - mI)/(MI + mI)$$

Where:

- o MI = Maximum irradiance,
- o mI = Minimum irradiance,

With the maximum and minimum irradiance measured with the detectors over the nominated test area (corrected for temporal instability).

**Table 10-3: Classes of solar simulators with respect to nonconformity of irradiance uniformity**

Class	Class A	Class B	Class C
Nonconformity (%)	± 2	± 5	± 10

- f. The irradiance uniformity of the Sun simulator in the test plane shall not introduce errors due to the positioning accuracy of the relevant cells higher than 1 % or other value proposed by the supplier and accepted by the customer.
- g. The irradiance uniformity of the Sun simulator in the test area shall not introduce errors due to the dimension of the reference cell used to adjust Sun simulator irradiance to AM0 equivalent conditions higher than 1 % or other value proposed by the supplier and accepted by the customer.

NOTE See clause 10.2 for requirements of reference solar cells.

### 10.1.3 Irradiance stability

- a. For the regular time interval of data acquisition of a particular test the irradiance, shall be stable to the degree specified for one of the corresponding class of solar simulator in Table 10-4.

NOTE See requirement 10.2.6.1c for solar simulator verification.

- b. For multi-source simulators used for characterizing multijunction solar cells, the relevant class of solar simulator in Table 10-4 shall be determined for each junction.
- c. The temporal (the time in between two consecutive calibrations of the solar simulator) instability shall be calculated with the following expression:

$$\text{Temporal instability (\%)} = 100 \times (MI - mI) / (MI + mI)$$

Where :

- o MI = Maximum irradiance,
- o mI = minimum irradiance

with the maximum and minimum irradiance measured with the detector at any particular point of the nominated test area plane during the time of data acquisition.

**Table 10-4: Classes of solar simulators with respect to temporal instability of irradiance**

Class	Class A	Class B	Class C
Nonconformity (%)	± 1	± 5	± 10

- d. The irradiance stability of the Sun simulator in the test plane shall be capable to guarantee reproducibility and, thus, not introduce errors on measured solar cell electrical parameters ( $I_{sc}$ ,  $V_{oc}$ , and  $P_{max}$ ) higher than 1 % or other value proposed by the supplier and accepted by the customer.

## 10.2 Standard cell and Sun simulator calibration

### 10.2.1 Primary standards

- a. Single junction or component primary standard cells, calibrated using a method defined in ISO 15387:2005, shall be used for setting light sources to standard illumination conditions.
- b. The number and type of primary standard cells shall be mutually agreed upon between the supplier and the customer.

## 10.2.2 Secondary working standards (SWS)

### 10.2.2.1 Selection of secondary working standards

- a. For single junctions, 10 solar cells representing a spectral response range similar when compared in conformance with requirement 10.2.2.1d to that of the cells to be tested, shall be calibrated for their AM0 equivalent short-circuit current using a Sun simulator, conforming to clause 10.1, using the accepted primary standards
- b. For multi-junctions, three sets of component solar cells representing a spectral response range similar when compared in conformance with requirement 10.2.2.1d to the cells to be tested, shall be calibrated for their AM0 equivalent short-circuit current using a multi-source solar simulator, conforming to clause 10.1, using the accepted primary standards.
- c. Cells shall be matched in its size to the cells under test.
- d. The comparison method shall be agreed with the customer.

### 10.2.2.2 Irradiated secondary working standards

- a. Electron or proton irradiated secondary working standards shall be calibrated to adjust solar simulator irradiance at the test plane to AM0 equivalent intensity when measuring the electrical performance of bare cells or SCAs irradiated with the same dose and particle energy.
- b. The number of irradiated SWS shall be agreed between the supplier and the customer.

### 10.2.2.3 Secondary working standards performance requirements

#### 10.2.2.3.1 Visual inspection requirements.

- a. SWS shall meet visual inspection requirements on defects (clauses 7.5.1.4 and 7.5.1.5 for bare solar cells, or clause 6.4.3.1 for SCA's).
- b. Any deviation from the visual inspection requirements on defects shall:
  1. not affect performance or reliability,
  2. be agreed with the customer, and
  3. be justified.

#### 10.2.2.3.2 Stability of the sensitivity

- a. The stability of the sensitivity of the SWS under operating conditions shall be verified by comparing the short-circuit current of five of the SWS before and after a photon-irradiation test with the short-circuit current of the remaining five SWS which are kept in the dark.
- b. If the average short-circuit current of the photon-irradiated cells deviates by more than 1 % from the original values, a new set of SWS shall be selected from a different production process established to yield stable cells.

- c. The spectral response range of these cells shall be verified by spectral response measurements and the subsequent calculation of mismatch errors between the SWS and production cells, in conformance with requirement 10.2.2.3.2d.
- d. The maximum error shall not be higher than 1 %.

#### 10.2.2.3.3 Linearity

- a. For linearity measurements methods, annex I of ISO 15387:2005 shall be applied.
- b. Current and Voltage Linearity Test with respect to irradiance and temperature range of interest shall be verified:
  - 1. The variation of the slope of short circuit to irradiance remains constant within 2 %.
  - 2. The variation of the slope of open circuit voltage to the logarithm of irradiance [ $\ln(G)$ ] remains constant within 5 %.
  - 3. The variation of the slope of short-circuit current and open circuit voltage to cell temperature remains constant within 10 %.

#### 10.2.2.3.4 Use of SWS with pulse solar simulator

- a. For their use with pulsed simulators, it shall be verified by using a memory oscilloscope, that SWSs have a response in short-circuit mode capable to generate the AM0 equivalent short-circuit current.

#### 10.2.2.3.5 Verification of SWS

- a. Correlation measurements between the SWS in daily use and a primary standard shall be made at intervals mutually agreed upon between the supplier and the customer.

### 10.2.3 Standards cells documentation

- a. The following data shall be reported when using a standard cell:
  - 1. Cell description (identification, type, size),
  - 2. Calibration data with uncertainty budget,
  - 3. calibration type,
  - 4. calibration laboratory,
  - 5. calibration light source class spectrum,
  - 6. If primary standard and SWS have a different size, stability and uniformity,
  - 7. Normalized spectral response curve,
  - 8. Temperature Coefficients and calibration date.

## 10.2.4 Maintenance of standards

- a. All standard solar cells (primary and SWS) shall be kept at temperatures below 50 °C during operation and storage.
- b. The standard cells shall be kept in the dark during storage periods of more than one month.

## 10.2.5 Recalibration and intercomparison

- a. Periodically recalibration and intercomparison shall be made in a period agreed with the customer.
- b. Those cells that do not meet the stability requirements (> 1 % change per year in short circuit current) shall be discarded as reference cells.

## 10.2.6 Sun simulator calibration and maintenance

### 10.2.6.1 Sun simulator calibration

- a. The irradiance in the test plane shall be adjusted to the AM0 equivalent intensity by means of an SWS for single junction solar cells with a deviation from the calibrated short-circuit current of the SWS not be higher than 1 %.
- b. For multi-junction solar cells, the irradiance in the test plane shall be adjusted to AM0 equivalent conditions for each component cell with a maximum allowable deviation of 1 % in the calibrated short-circuit current of each SWS component cell.
- c. The simulator intensity shall be verified with the aid of the SWS at regular intervals.
- d. The length of the intervals specified in requirement 10.2.6.1c shall be:
  1. such as to guarantee an intensity drift of less than 1 % between two subsequent SWS measurements;
  2. specified by the manufacturer in the product assurance plan.

### 10.2.6.2 Sun simulator maintenance

- a. Sun simulator performance shall be periodically verified in conformance with clause 10.1 in the following cases:
  1. Immediately after the Sun simulator lamp or any part of the optical system has been changed, cleaned or repaired.
  2. Every 500 hours (continuous illumination) or every 5 000 flashes (pulsed) of lamp, or every period proposed by the supplier and accepted by the customer.

NOTE The requirement of 5 000 flashes of lamp is to take into account lamp aging.

# 11

## Capacitance measurement methods

---

### 11.1 Single junction solar cell capacitance measurement

#### 11.1.1 Overview

##### 11.1.1.1 Introduction

This method is intended to be used for the measurement of capacitance of bare solar cells and solar cell assemblies, and as an outline for qualification coupons (see requirements 5.5.3.5.2a and 6.4.3.16.2a).

##### 11.1.1.2 Description

This clause describes a method of measuring the dynamic properties of a single junction solar cell, using the small signal method. This consists of measurement of the cell impedance in darkness for several bias voltages.

The measurement is performed between 0 V and the bias voltage corresponding to a current of 200 mA. The frequencies are between 10 Hz and 10 MHz.

These measurements enable the cell capacitance for each bias voltage to be estimated and, subsequently, to build a model of the capacitance according to the cell voltage and current.

The following parameters and values are used

- The minimum number of frequencies is  $N_f = 26$  with logarithmic steps
- The minimum number of voltage biases is  $N_p = 6$
- $V_1 = 0$  V
- $V_2 = V_3 / 2$
- $V_3 =$  bias voltage corresponding to a current of 1 mA
- $V_4 =$  bias voltage corresponding to a current of 10 mA
- $V_5 =$  bias voltage corresponding to a current of 100 mA
- $V_6 =$  bias voltage corresponding to a current of 200 mA

## 11.1.2 Signal measurement method

- a. The signal measurement method that should be used is the shunt method.

## 11.1.3 Measurement procedure

### 11.1.3.1 Preparation of the measurement equipment

- a. The test bay should be prepared according to Figure 11-1 and the following equipment list:

1. One DC power supply.
2. Two precision voltmeters.
3. One 4-points ohmmeter (or one of the 2 voltmeters if they are multi-meters).
4. One network analyser.
5. The measuring head containing one non-inductive shunt ( $1\ \Omega$ ) and connections for BNC cables and the voltmeters, with the following:
  - (a) The hot terminal of the shunt to the voltmeters connected to the voltmeters via an air coil inductance higher than  $45\ \mu\text{H}$ .
  - (b) A resonance frequency higher than 10 MHz and damped by a  $270\ \Omega$  resistor in parallel.

NOTE This device is used to suppress the influence of the harness and the parasitic capacitances of the voltmeters on the shunt in the measuring bandwidth.

- (c) The coil made with a 10 mm diameter Teflon mandrel of roughly 125 jointed turns of a 2/10 mm wire.
6. The injection elements with the following properties:
  - (a) Direct current:  $200\ \Omega$  resistor, power 10 W, stable with regard to the temperature.
  - (b) Alternating current: electrochemical capacitance of  $1000\ \mu\text{F}$  and four common mode cores T22 FT40.
  - (c) One  $50\ \Omega$  cable for injection passing through the 4 common mode cores.
7. A ground braid between the analyser ground and the measuring head.
8. Two  $50\ \Omega$  cables of same length for measurement.
9. Two twisted unshielded cables for voltmeter connection with a maximum length of 1,50 m.
10. One male BNC adapter.

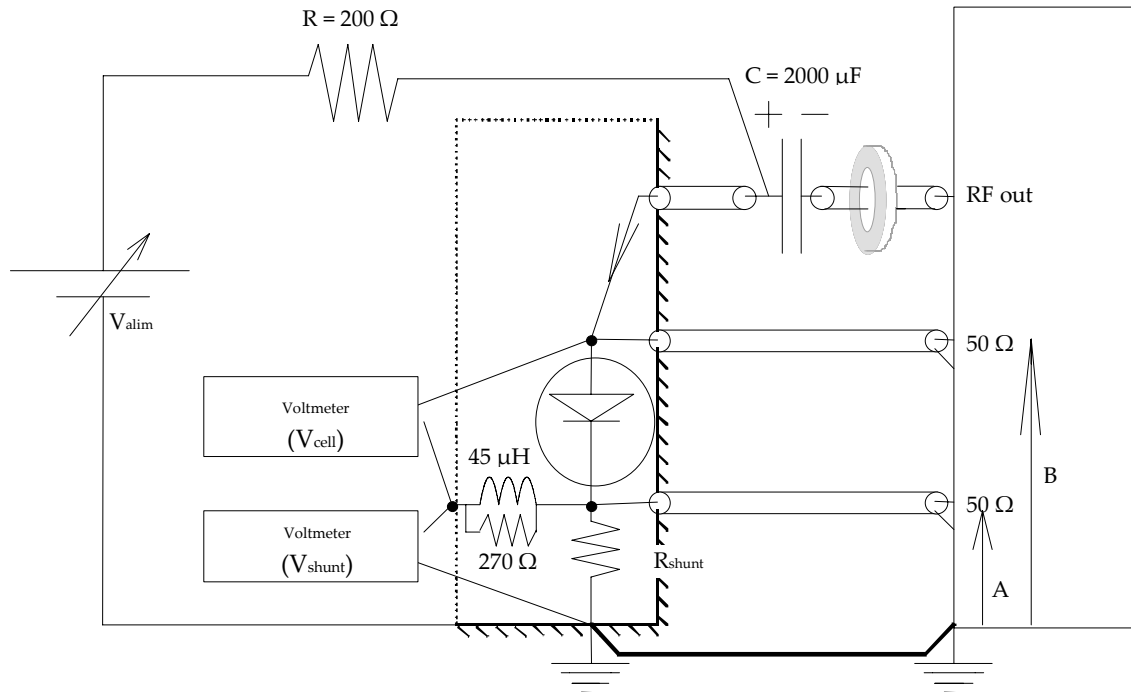

**Figure 11-1: Solar cell impedance measurement equipment**

- b. The parameters of the network analyser should be adjusted using the network analyser in the  $B/A$  mode ( $B/A = (V_{\text{cell}} + V_{\text{shunt}}) / V_{\text{shunt}}$ ), ensuring that the channels are not inverted, as follows:
1. frequency range: 10 Hz to 10 MHz;
  2. number of frequencies  $N_f$ : at least 26;
  3. step type: logarithmic;
  4. bandwidth: automatic or otherwise limited to few Hz in order to limit the noise at low frequency;
  5. injection level: default value of the network analyser;
  6. program the network analyser to record the  $B/A$  values in the complex form  $X + j \times Y$ ; or in the amplitude  $|B/A|$  and phase  $\varphi(B/A)$ .

#### 11.1.3.2 Process for calibration of the test equipment

- a. The balancing of the channels at low frequency, and the influence of the parasitic inductance between the two measuring points, A and B, once before the measurements should be verified by replacing the solar cell with a short-circuit according to Figure 11-2.
- b. The  $B/A$  ratio between 10 Hz and 10 MHz should be ensured to conform to the following provisions:
  1. At low frequency: equal to  $(1 \pm 2) \%$  (or equal to  $(0 \pm 2) \text{ dB}$ ).



2. At 10 MHz: lower than 1,6 (or 4 dB).

NOTE It is considered that the shunt has no inductance; this means that the inductance of the short-circuit is lower than 20 nH. A ratio lower than 1 (or < 0 dB) means that the A and B channels are inverted.

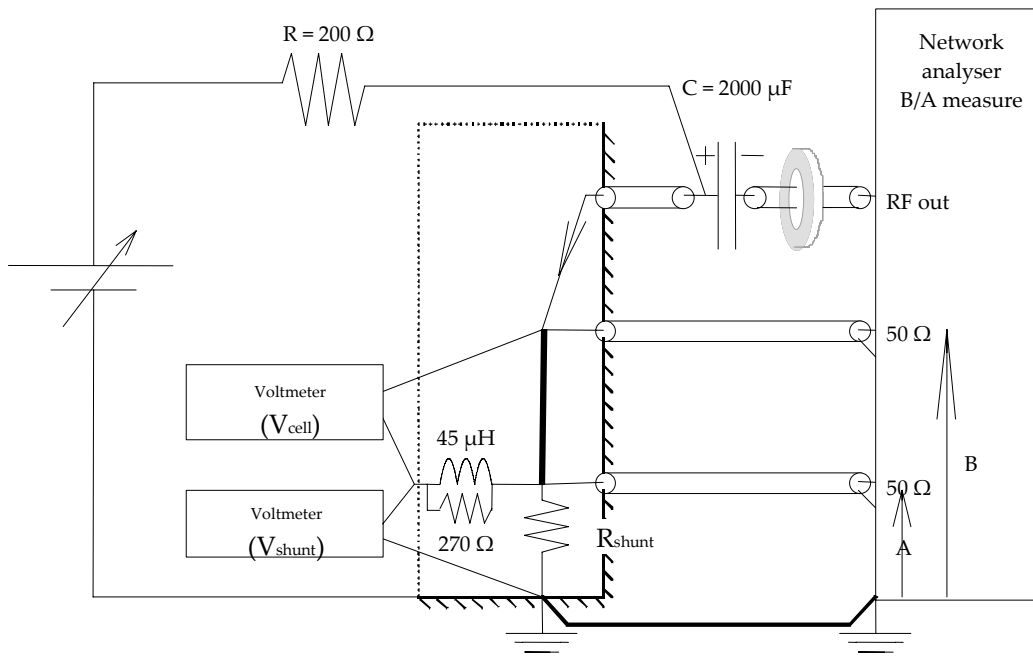

**Figure 11-2: Channel balancing and reduction of the parasitic inductances**

- c. The ohmic value of the shunt associated with the cabling and the network analyser should be measured at room temperature using one of the following two methods:
1. Calculation: to be used if the certified calibrated value of the shunt, of the cable and of the 50  $\Omega$  input are known.

In this case:

$$R_{\text{shunt measured}} = \frac{1}{1/R_{\text{shunt}} + 1/(R_{50\Omega \text{ input}} + R)}$$

2. Direct measurement: measure  $R_{\text{shunt measured}}$  with the cell short-circuited, the channel A plugged on the network analyser, all the other cables unplugged (Figure 11-3), and a 4-wire setting, as follows:
  - (a) unplug the injection cable (RF channel);
  - (b) unplug the  $V_{\text{cell}}$  measuring cable and keep it insulated;

- (c) unplug the cable on channel B of the network analyser and plug it into the input "input" of the ohmmeter with a BNC adaptor, paying attention to the polarities;
- (d) unplug the measuring cable  $V_{shunt}$  and plug it in the input "sense" of the ohmmeter, paying attention to the polarities;
- (e) monitor the calculated or measured value.

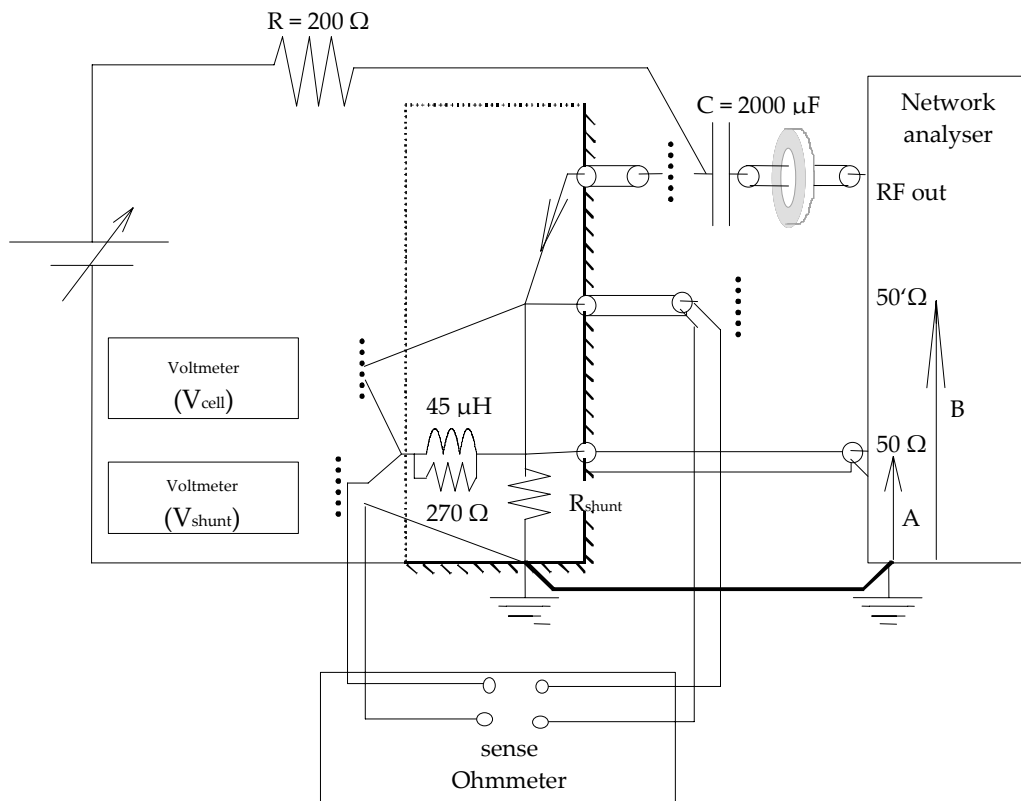

**Figure 11-3: Measurement of the resistance value of the shunt in the measuring conditions (shunt in parallel with the input of the network analyser)**

- d. Adjust the injection level of the network analyser as follows:
  1. Connect the cell in place of the short-circuit and keep the voltage supply at 0 V.
 

NOTE The injection level is selected low enough so as not to generate a variation of the impedance curves when the level changes.
  2. Begin at 0 dB and lower the signal with 3 dB steps until there is no change at low frequency (variation lower than 0,1 dB).
  3. Monitor the selected injection level.

### 11.1.3.3 Measurement of the cell with the network analyser

- a. The cell should be measured with the network analyser as follows:
  1. If the measurement is performed at several temperatures in a thermostatic chamber:
    - (a) Wait for thermal equilibrium.
    - (b) Determine the resistance value of the shunt at each temperature (requirement 11.1.3.2c).
  2. Determine and record the voltage of the power supply to obtain the bias voltages defined in clause 11.1.1.2 and set the power supply to 0 V at the end.
  3. Measure the  $B/A$  ratios for the chosen bias voltages, as follows. For each bias voltage:
    - (a) Adjust the power supply voltage to the determined value.
    - (b) Note the cell and the shunt voltages.
    - (c) Measure the  $B/A$  ratios in the complex form  $X+j \times Y$ ; or in the amplitude  $|B/A|$  and phase  $\varphi (B/A)$  from 10 Hz to 10 MHz, and store the data file in the network analyser.
    - (d) Note or record the cell voltage change (to detect a temperature increase of the cell).
    - (e) Set the power supply voltage to 0 V.
    - (f) Record the stored data file.

## 11.1.4 Measurement analysis

### 11.1.4.1 Correction of the measurement with respect to the actual impedance of the shunt (impedance values from the $B/A$ measurements)

- a. For a  $1 \Omega$  shunt, the value given by the analyser is the impedance of the cell in series with the  $1 \Omega$  resistor, where the cell impedance should be determined using the following calculation:

1. If  $B/A$  is given in amplitude  $|B/A|$  and phase  $\varphi (B/A)$ , the cell impedance is:

$$Z_{\text{cell}} = R_{\text{shunt measured}} \times \left[ 1 + |B/A|^2 - 2 \cos(\varphi) B/A \right]^{1/2}$$

2. If  $B/A$  is given in the complex form  $X+j \times Y$

$$Z_{\text{cell}} = R_{\text{shunt measured}} \times [ 1 + X^2 + Y^2 - 2X ]^{1/2}$$

### 11.1.4.2 Modelling

#### 11.1.4.2.1 Calculation of the items of the equivalent network using the impedance values

- a. The small signal electrical model parameters (Figure 11-4) should be calculated for each bias voltage  $V_{cell,i}$  and bias current  $I_{cell,i}$  with respect to the frequency, as follows:

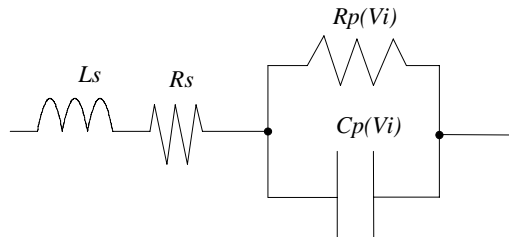

$$Z_{theo}(L_s, R_s, C_p, R_p, f) = \left[ \left( R_s + \frac{R_p}{1 + 4\pi^2 R_p^2 C_p^2 f^2} \right)^2 + 4\pi^2 f^2 \left( L_s - \frac{R_p^2 C_p}{1 + 4\pi^2 R_p^2 C_p^2 f^2} \right)^2 \right]^{1/2}$$

**Figure 11-4: Small signal electrical schema biased with a DC voltage associated impedance**

1. Minimize the relative error of the theoretical impedance  $Z_{theo}(L_s, R_s, C_p, R_p, f)$  with the measured values (regression by least square method).

NOTE As the  $N_f$  impedance measurements

$$\begin{pmatrix} Z_{cell,1} \\ Z_{cell,2} \\ \dots \\ Z_{cell,N_f} \end{pmatrix}$$

are associated to the frequencies

$$\begin{pmatrix} f_1 \\ f_2 \\ \dots \\ f_{N_f} \end{pmatrix}$$

the function to minimize is

$$\sum_{j=1}^{N_f} \left[ 1 - \frac{Z_{theo}(L_s, R_s, C_p, R_p, f_j)}{Z_{cellj}} \right]^2$$

which is a function of  $L_s$ ,  $R_s$ ,  $C_p$  and  $R_p$ .

2. Calculate each parameter  $R_p$ ,  $C_p$ ,  $L_s$  and  $R_s$  by successive iterative optimization, one after the other, using the following initial parameters:

$$R_p0 = Z(f_{MIN}),$$

$$C_p0 = 1 / (2 \times \pi \times f_{MIN} Z(f_{MIN})),$$

$$L_s0 = Z(f_{MAX}) / (2 \times \pi \times f_{MAX}),$$

$$R_s0 = \text{minimum value of } Z(f).$$

#### 11.1.4.2.2 Determination of the capacitance model

- a. From the capacitance measurements at several bias voltages, the following parameters of the model of capacitance should be determined with respect to the cell junction voltage and temperatures:
1.  $C_0$  (capacitance at 0 V),
  2.  $C_1$  (diffusion parameter), and
  3.  $\Phi$  (voltage barrier at measurement temperature),
- b. Provision 11.1.4.2.2a should be determined as follows:
1. Use the capacitance model based on the following expression:

$$C(v) = \frac{C_0}{\sqrt{1 - v/\Phi}} + C_1 \exp\left(\frac{v}{v_0}\right)$$

where

- $v_0 = \frac{kT}{q}$
- $T$  = measurement temperature
- $k = 1,38 \times 10^{-23}$  J/K
- $q = 1,602 \times 10^{-19}$  C

NOTE For measurement in darkness and low currents, the cell voltage  $V_i$  and the junction voltage  $v_i$  are the same (the error is 4 mV for a bias current of 200 mA and a cell serial resistance of 20 m $\Omega$ ).

2. Minimize the relative error between the theoretical capacitance  $C(C_0, \Phi, C_1, v)$  and the previously calculated capacitances (regression by least square method).

NOTE As the  $N_p$  impedance measurements

$$\begin{pmatrix} C(V_1) \\ C(V_2) \\ \dots \\ C(V_{N_p}) \end{pmatrix}$$

are associated to the voltages

$$\begin{pmatrix} V_1 \\ V_2 \\ \dots \\ V_{N_p} \end{pmatrix}$$

the function to minimize is

$$\sum_{j=1}^{N_f} \left[ 1 - \frac{C(V_j, C_0, \Phi, C_1)}{C(V_j)} \right]^2,$$

which is the function of  $C_0$ ,  $\Phi$  and  $C_1$ .

- c. Calculate each parameter  $C_0$ ,  $C_1$  and  $\Phi$  by successive iterative optimization one after the other, where the initial parameters are as follows:

$$\begin{aligned} C_0 &= C(V_1) \\ C_1 &= \exp\left(-\frac{v}{v_0}\right) C(V_{N_p}) \\ \Phi &= 1, 5 V_{N_p} \end{aligned}$$

### 11.1.5 Measurement of the capacitance of a multi-junction cell

The cell capacitance measurement method cannot be directly applied to multi-junction solar cells because it assumes that the photo-currents of each junction of the cell were perfectly matched.

For real cells, this matching is not realized and the voltage profile through the different junctions of the cell is different when the cell is illuminated and when it is in darkness. The measurement in darkness enables the order of magnitude of the capacitance to be evaluated.

In order to obtain a higher precision, these measurements are added to measurements under illumination with the right spectral irradiance.

NOTE 1 Some measurements have been performed and the capacitance has been observed to be higher than the values measured in darkness, even at low bias voltage. This is under experimentation and currently there is not a lot of information available.

NOTE 2 This is the fundamental difference between single junction and multi-junction cells: measurements done in darkness are sufficient to characterize the dynamic behaviour of single junction cells in darkness and under illumination.

NOTE 3 Measurements done in darkness are not sufficient to characterize the dynamic behaviour of multi-junction cells under illumination.

## 11.2 Time domain capacitance measurement

### 11.2.1 Overview

#### 11.2.1.1 Introduction

This method is intended to be used for the measurement of the capacitance of SCAs and qualification coupons that are part of power subsystems that use sequential switching shunt regulators.

#### 11.2.1.2 Description

This clause describes a method for measuring the dynamic properties of a solar cell or qualification coupon, using the time domain method while operating in the current region (to the left of the maximum power point on the curve).

The capacitance of the solar cell or qualification coupon, when switching between two different voltage operational points with the assumptions that

- the capacitance is constant between the two points, and
- the current is constant in the two points,

is obtained with the expression:

$$C = \frac{I \times \Delta t}{\Delta v},$$

where

- $I$  is the measured current at the two points;
- $\Delta t$  is the time increment;
- $\Delta V$  is the voltage increment.

The measurements are performed at 1 S.C (AM0) illumination and at constant temperature.

The capacitance that is derived from the short-circuit current point and the operational voltage of the solar cell or qualification coupon is used to derive the requirements for the design of sequential switching shunt regulators specified in ECSS-E-ST-20.

### 11.2.2 Measurement procedure

#### 11.2.2.1 Measurement equipment set-up

- a. The time domain capacitance measurement test set-up, should comprise the following test equipment:
  1. A continuous or pulsed solar simulator according to the requirements specified in clause 10.
  2. A solar array capacity tester which supplies a synchronizable fast switch to perform a controlled short-circuit release at the open circuit condition of the qualification coupon or SCA under test.

3. A digital-analogue oscilloscope to capture the voltage-current transient during the short-circuit release at the open circuit condition.
  4. A twisted harness of short length to reduce the parasitic inductance of the harness from the test specimen to the capacity tester.
- b. The voltage should be measured at the test specimen terminals.
  - c. For qualification coupons with multiple strings, each particular string voltage should be measured not including the string blocking diode (see requirement 5.5.1.3.3f).
  - d. External parallel capacitors to derive the capacitance of the qualification coupon or SCA should not be used because this parameter depends on the rate of change of the transient.

#### **11.2.2.2 Calibration of the measurement equipment**

- a. The continuous or pulsed solar simulator should be calibrated according to the requirements specified in clause 10.2.

#### **11.2.2.3 Performance measurement**

- a. The short-circuit release at the open circuit condition of the SCA or qualification coupon should be performed under the illumination conditions specified in clause 11.2.2.2 and at constant temperature.
- b. The voltage curve vs time and the current curve vs time of the test specimen should be recorded during the release.

#### **11.2.2.4 Data processing**

- a. Since the voltage of the test specimen at the moment of the short-circuit release is difficult to measure (due to the high frequency oscillations created by the parasitic harness inductance), one of the following two methods should be used to determine the voltage:

- mathematical analysis to find a curve without oscillation that fits the voltage curve measured;
- calculation of the intersection of two voltage curves.

NOTE Example of two voltage curves that can be used for this purpose are the first voltage curve at the test specimen terminals and the second voltage curve at the capacity tester terminal (+) and test specimen terminal (-).

- b. The voltage determined in requirement 11.2.2.4a should be used to calculate the capacitance according to the expression and conditions specified in clause 11.2.1.2.



# Annex A (normative)

## Source control drawing for photovoltaic assembly (SCD-PVA) - DRD

---

### A.1 DRD identification

#### A.1.1 Requirement identification and source document

This DRD is called from ECSS-E-ST-20-08, requirement 5.2b.

#### A.1.2 Purpose and objective

The source control drawing for photovoltaic assembly (SCD-PVA) contains the specific project dependent requirements, and together with this Standard, which contains the general requirements, constitutes the whole set of requirements for the qualification and acceptance of photovoltaic assemblies.

The SCD-PVA can be produced as a standalone document or as part of a system-level specification document.

The information on traceability to high level requirements can be included in the SCD-PVA itself or in the requirements traceability in the design justification file (DJF, see ECSS-E-ST-10). In either case a cross reference is made.

The SCD-PVA is a major input to the qualification plan.

### A.2 Expected response

#### A.2.1 Scope and content

##### <1> Introduction

- a. The SCD-PVA shall contain a description of the purpose, objective, content and the reasons prompting its preparation.

##### <2> Applicable and reference documents

- a. The SCD-PVA shall list the applicable and reference documents to support the generation of the document.

**<3> Terms and definitions, abbreviated terms and symbols**

- a. The SCD-PVA shall include any additional definition, abbreviation or symbol used.

**<4> Deviations from ECSS-E-ST-20-08**

- a. In conformance with clause 5.2, the SCD-PVA shall include the description and justification for any deviation in the in-process, acceptance and qualification tests.

**<5> Qualification test coupons**

- a. In conformance with clause 5.5.1.3.3, the SCD-PVA shall include the following:
  1. In conformance with clause 5.5.1.3.3, the SCD-PVA shall include the front and rear side drawings of each qualification coupons with physical dimensions and including tolerances.
  2. In conformance with clause 5.5.1.3.3, the SCD-PVA shall include the number of repaired cells to be included on each qualification coupon.

**<6> In-process tests****<6.1> Mass measurement**

- a. The SCD-PVA shall state the maximum value of the mass of the coupon, in g, obtained from the mass measurement specified in clause 5.4.3.2.

**<6.2> Wet insulation**

- a. In conformance with clause 5.4.3.3, the SCD-PVA shall state:
  1. The test voltage, in V.
  2. The fluid to use.
  3. The minimum value for the wet insulation, in M $\Omega$ .

NOTE 1 The fluid used is normally ethyl or isopropyl.

NOTE 2 A usual value for the wet insulation is 100 M $\Omega$ .

**<6.3> Adherence to substrate**

- a. In conformance with clause 5.4.3.4, the SCD-PVA shall state the minimum flatwise tensile strength, in N.

**<6.4> In-process visual inspection**

- a. In conformance with clause 5.4.3.5, the SCD-PVA shall state the visual inspection procedure.

**<6.5> In-process continuity**

- a. In conformance with clause 5.4.3.6, the SCD-PVA shall state the maximum value of the resistance, in  $\Omega$ .

**<7> Qualification tests****<7.1> Fatigue thermal cycling**

- a. In conformance with clause 5.5.1.3, the SCD-PVA shall state the following:
  1. The following test conditions:
    - (a) the number of cycles to perform;
    - (b) the temperature limits, in  $^{\circ}\text{C}$ .
  2. For the acceptance criteria:
    - (a) the maximum variation of  $I_{OP}$ , in %;
    - (b) the minimum insulation, in  $M\Omega$ .

**<7.2> Humidity**

- a. In conformance with clause 5.5.1.4, the SCD-PVA shall state:
  1. The chemical contents (type and % in the mist) of the humid environment when there are specific requirements on the contents of the environment.
  2. For the acceptance criteria:
    - (a) the maximum variation of  $I_{OP}$ , in %;
    - (b) the minimum insulation, in  $M\Omega$ .

**<7.3> Erosion of materials**

- a. In conformance with clause 5.5.1.6, the SCD-PVA shall state the test sequence, test definitions and requirements for the erosion of materials test.

**<7.4> EMC**

- a. In conformance with clause 5.5.1.7, the SCD-PVA shall state the test sequence, test definitions and requirements for the EMC test.

**<8> Definition of tests and checks****<8.1> Add-on mass**

- a. In conformance with clause 5.5.3.1, the SCD-PVA shall state the maximum add-on mass of the coupon, in g, obtained from a mass measurement.

**<8.2> Full visual inspection**

- a. The SCD-PVA shall state:

1. The maximum number of cell cracks on the coupons (in conformance with requirement 5.5.3.2.8a.1).
2. The maximum number of gridlines that a cell crack can cross (in conformance with requirement 5.5.3.2.8a.2).
3. The inspection criteria for solar cells on substrates (in conformance with clause 5.5.3.2.5).

### <8.3> Electrical health

- a. For electrical continuity check, in conformance with clause 5.5.3.3.2, the SCD-PVA shall state the following conditions for checking the continuity of the strings:
  1. current to be applied, in A, or voltage to be measured, in V.
  2. specified illumination to performed the measurement.
- b. For insulation resistance, the SCD-PVA shall state the minimum insulation resistance, in  $M\Omega$ , at a test voltage specified in V, for the configurations specified in clause 5.5.3.3.3.
- c. For grounding spot resistance, in conformance with clause 5.5.3.3.4, the SCD-PVA shall state:
  1. The maximum value, in  $\Omega$ , of the resistance of bleed resistor lead (+) to substrate (-).
  2. The maximum value, in  $\Omega$ , of the grounding spots (+) to substrate (-).
- d. For bleed resistor test, in conformance with clause 5.5.3.3.5, the SCD-PVA shall state the range of values, in  $k\Omega$ , of the bleed resistor.
- e. For blocking diode test, in conformance with clause 5.5.3.3.6, the SCD-PVA shall state:
  1. The  $I_{FORWARD}$  in A, and the  $V_{REVERSE}$  in V, of the blocking diode.
  2. The values for  $V_{FORWARD}$ , in V, and  $I_{REVERSE}$ , in A, to be obtained from the test.
- f. For shunt diode, in conformance with clause 5.5.3.3.7, the SCD-PVA shall state:
  1. The  $I_{FORWARD}$ , in A, to be used, and the maximum drop of forward voltage, in V, per cell, to be obtained from the test.
  2. The test method to be used.
  3. The maximum temperature, specified in  $^{\circ}C$ .
- g. For thermal sensor test, in conformance with clause 5.5.3.3.8, the SCD-PVA shall state:
  1. The resistance of the thermal sensor as a function of the temperature.
  2. The range of resistance to be obtained from the test, in  $\Omega$ .

NOTE A reference to a calibration table, included in the SCD, can be used.

- h. For resistance measurements, in conformance with clause 5.5.3.3.9, the SCD-PVA shall state the maximum value of the resistance, in  $\Omega$ , between the (+)/(+) and (-)/(-) ends of the harness.

#### <8.4> Electrical performance

- a. In conformance with clause 5.5.3.4.2, the SCD-PVA shall state the following values, together with their inaccuracies, recalculated to 25 °C, for 1 S.C. (AM0) (as defined in clause 10), providing the test voltage VOP range (specified in V), and the temperature range (specified in °C):
1. the nominal value of the  $I_{OP,MIN}$ , in A;
  2. the nominal value of  $V_{P,MAX}$ , in V;
  3. the nominal value of  $V_{OC}$ , in V;
  4. the nominal value of  $I_{P,MAX}$ , in A;
  5. the nominal value of  $I_{SC}$ , in A.

#### <8.5> Capacitance

- a. In conformance with clause 5.5.3.5, the SCD-PVA shall state a procedure to measure the capacitance, including the test temperature (average operational temperature).

#### <8.6> Bake-out

- a. In conformance with clause 5.5.3.6, the SCD-PVA shall state: the test conditions, as a combination of time and temperature.

#### <8.7> Acceptance thermal cycling test

- a. In conformance with clause 5.5.3.7, the SCD-PVA shall state:
1. The following test conditions for the tests specified in clause 5.5.3.7:
    - (a) The number of cycles to perform.
    - (b) The temperature limits, in °C.
  2. For the acceptance criteria:
    - (a) The maximum increment of  $I_{OP}$ , in %.
    - (b) The minimum insulation, in  $M\Omega$ .

#### <8.8> Reflectance

- a. In conformance with clause 5.5.3.8, the SCD-PVA shall state the maximum reflectance change, in %, for the following wavelength bands:
1.  $\lambda \leq 300$  nm;
  2.  $300 \text{ nm} < \lambda < 900$  nm;
  3.  $900 \text{ nm} < \lambda < 1\,800$  nm.

**<8.9> Transmission**

- a. In conformance with clause 5.5.3.9, the SCD-PVA shall state the acceptance criteria for the change in transmission due to contamination in the band of  $280 \text{ nm} < \lambda < 2500 \text{ nm}$ .

**<8.10> X-ray**

- a. In conformance with clause 5.5.3.9, the SCD-PVA shall state the acceptance criteria, for the integrity of:
  1. busbars,
  2. wire collection strips, and
  3. diode boards.

**<8.11> Substrate integrity**

- a. In conformance with clause 5.5.3.10, the SCD-PVA shall state:
  1. The test method, either airscan, or C-scan, or destructive test, for the integrity of the skin to honeycomb.
  2. The acceptance criteria.

**<8.12> Vacuum thermal cycling**

- a. In conformance with clause 5.5.3.11, the SCD-PVA shall state the maximum acceptable degradation, as follows:
  1. The maximum increment for  $I_{OP}$ , in %.
  2. The minimum insulation, in  $M\Omega$ .

**A.2.2 Special remarks**

None.

---

# Annex B (normative)

## Source control drawing for solar cell assembly (SCD-SCA) - DRD

---

### B.1 DRD identification

#### B.1.1 Requirement identification and source document

This DRD is called from ECSS-E-ST-20-08, requirement 6.1.2b.

#### B.1.2 Purpose and objective

The source control drawing for solar cell assembly (SCD-SCA) contains the specific project dependent requirements, and together with this Standard, which contains the general requirements, constitutes the whole set of requirements for the qualification and acceptance of solar cell assemblies.

The SCD-SCA can be produced as a standalone document or as part of a system-level specification document.

The information on traceability to high level requirements can be included in the SCD-SCA itself or in the requirements traceability in the design justification file (DJF, see ECSS-E-ST-10). In either case a cross-reference is made.

The SCD-SCA is a major input to the qualification plan.

### B.2 Expected response

#### B.2.1 Scope and content

##### <1> Introduction

- a. The SCD-SCA shall contain a description of the purpose, objective, content and the reason prompting its preparation.

##### <2> Applicable and reference documents

- a. The SCD-SCA shall list the applicable and reference documents to support the generation of the document.

**<3> Terms and definitions, abbreviated terms and symbols**

- a. The SCD-SCA shall include any additional definition, abbreviation or symbol used.

**<4> Deviations from ECSS-E-ST-20-08**

- a. In conformance with clause 6.1.2, the SCD-SCA shall include the justification for any deviation in the in-process, acceptance and qualification tests.

**<5> Materials**

- a. The SCD-SCA shall include the following solar cell characteristics:
  1. For silicon solar cells:
    - (a) growth technique, base resistivity, and thickness.
    - (b) for ARC: materials
    - (c) for metal contact materials and thickness
  2. For GaAs single or multi-junction solar cells:
    - (a) for the substrate: type of material and thickness;
    - (b) for each sub-cell: materials,.
    - (c) for ARC: materials
    - (d) for metal contact materials and thickness
  3. For interconnects:
    - (a) materials and dimensions, all metal layers and their thickness.
    - (b) joining technique, additional materials (if any) and reference to the procedure
  4. For coverglass: material, thickness, ARC, and conductive coating.
  5. For coverglass adhesive, material and outgassing rates and reference to the procedure for process details and cementing conditions.

NOTE See ECSS-Q-ST-70-02.

**<6> Test methods, conditions and measurements****<6.1> Dimensions and weight**

- a. In conformance with clause 6.4.3.2, the SCD-SCA shall include:
  1. A figure, showing the physical dimensions of the solar cell assembly, including both, the nominal values and tolerances.
  2. The average weight (per lot) of solar cell assemblies including the interconnector, in grams.



**<6.2> Electrical performance**

- a. In conformance with clause 6.4.3.3, the SCD-SCA shall include, the information shown in Table B-1, extended if there are several operational voltages at a solar cell temperature of 25 °C, under illumination of 1 S.C (AM0).

**Table B-1: Minimum current requirement for solar assemblies  
(25 °C or operating temperature)**

Sample	Irradiation dose	Test voltage $V_t$ (mV)	Current at $V_t$ (mA)
Minimum for individual solar cell assemblies	BOL	[Insert value]	[Insert value]
	EOL	[Insert value]	[Insert value]
Minimum average for solar cell assemblies	BOL	[Insert value]	[Insert value]
	EOL	[Insert value]	[Insert value]
Test temperature: [Insert value]			
NOTE: EOL is defined as 1 MeV $\Phi_p$ electron dose (in conformance with 6.4.3.12) plus photon irradiation and temperature annealing (in conformance with 6.4.3.13).			

**<6.3> Temperature coefficient**

- a. In conformance with clause 6.4.3.4, the SCD-SCA shall include the six equidistant solar cell temperatures to which the test is performed.

**<6.4> Spectral response**

- a. In conformance with clause 6.4.3.5, the SCD-SCA shall include for multi-junction GaAs solar cells, the number of narrow band interference filters and their wavelength.

**<6.5> Thermo-optical properties**

- a. In conformance with clause 6.4.3.6, the SCD-SCA shall include the following:
  1. The maximum value of the solar absorptance as a percentage of SCAs with tolerances.
  2. The maximum value of normal emittance as a percentage (%) of SCAs with tolerances.

**<6.6> Thermal cycling**

- a. In conformance with clause 6.4.3.7, the SCD-SCA shall include the number of cycles to be performed and their extreme temperatures, to simulate the number of eclipses occurring during one year in orbit for LEO missions, and 1000 thermal cycles for GEO missions, or the complete lifetime cycling for interplanetary or other mission types.

**<6.7> Humidity and temperature**

- a. In conformance with clause 6.4.3.8, the SCD-SCA shall include the chemical contents (type and % in the mist) to be added to the humid environment, when there are specific requirements on the contents of the environment.

**<6.8> Coating adherence**

- a. In case of coverglass with conductive coating, in conformance with clause 6.4.3.9, the SCD-SCA shall specify which of the two standards ISO 9211-4 or ECSS Q-ST-70-13 shall be applied

**<6.9> Interconnector adherence**

- a. In conformance with clause 6.4.3.10 the SCD-SCA shall include:
  1. the value of the pull speed, in mm/min;
  2. the pull direction
  3. the value of the separation pull strength of interconnectors, in N.

**<6.10> Electron irradiation**

- a. In conformance with clause 6.4.3.11, the SCD-SCA shall include:
  1. for mission specific qualification, the expected dose for the envisaged application,  $\Phi_p$ , at 1MeV, in  $e^- \text{cm}^2$ ;
  2. the electron irradiation at transfer orbit dose at 1MeV, in  $e^- \text{cm}^2$ , when specified by the mission requirements.

**<6.11> Surface conductivity**

- a. In conformance with clause 6.4.3.13, the SCD-SCA shall describe:
  1. The method to perform the surface conductivity test that shall be between the contact dots or an alternative one to be specified here in the SCD-SCA.
  2. The minimum value, in  $\Omega$ , and the maximum variation after any test, in  $\Omega$ , of the cover conductivity before and after qualification tests of SCA of subgroup D (in conformance with Table 6-1).

**<6.12> Solar Cell reverse bias test**

- a. In conformance with clause 6.4.3.14 (it is applicable only for SCAs without protection diode or with a protection diode electrically isolated from the cell).the SCD-SCA shall include:
  1. The reverse I/V characteristics measured under illumination of 1 S.C.;
  2. The following measurement parameters shall be clearly stated in the SCD-SCA
    - (a) power supply limitation
    - (b) temperature

- (c) hold time
- (d) maximum reverse bias voltage
- 3. The pass-fail criteria
  - (a) the maximum change in the value of reverse current  $\Delta I$ , in mA from the initial value of the same parameter when measured as delivered. Pass fail criteria shall be specified in the SCD-SCA.
  - (b) the maximum absolute value of the reverse current, in mA.

**<6.13> Ultraviolet exposure**

- a. In conformance with clause 6.4.3.15, the SCD-SCA shall include the following:
  - 1. The operational test temperature, in °C.
  - 2. The EOL UV loss factor.

**<6.14> Capacitance**

- a. In conformance with clause 6.4.3.16, the SCD-SCA shall include the test temperature, in °C and the capacitance test method as specified either in clause 11.1 or 11.2 of this Standard.

**<6.15> Flatness**

- a. In conformance with clause 6.4.3.17, the SCD-SCA shall include the minimum flatness, as a maximum deviation given in mm.

**B.2.2 Special remarks**

None.

---

# Annex C (normative)

## Source control drawing for bare solar cell (SCD-BSC) - DRD

---

### C.1 DRD identification

#### C.1.1 Requirement identification and source document

This DRD is called from ECSS-E-ST-20-08, requirement 7.1.1.2b.

#### C.1.2 Purpose and objective

The source control drawing for bare solar cell (SCD-BSC) contains the specific project dependent requirements, and together with this Standard, which contains the general requirements, constitutes the whole set of requirements for the qualification and acceptance of bare solar cells.

The SCD-BSC can be produced as a standalone document or as part of a system-level specification document.

The information on traceability to high level requirements can be included in the SCD-BSC itself or in the requirements traceability in the design justification file (DJF, see ECSS-E-ST-10). In either case a cross-reference is made.

The SCD-BSC is a major input to the qualification plan.

### C.2 Expected response

#### C.2.1 Scope and content

##### <1> Introduction

- a. The SCD-BSC shall contain a description of the purpose, objective, content and the reason prompting its preparation.

##### <2> Applicable and reference documents

- a. The SCD-BSC shall list the applicable and reference documents to support the generation of the document.

**<3> Terms and definitions, abbreviated terms and symbols**

- a. The SCD-BSC shall include any additional definition, abbreviation or symbol used.

**<4> Deviations from ECSS-E-ST-20-08**

- a. In conformance with requirement 7.1.1.2c, the SCD-BSC shall include the justification for any deviation in the in-process, acceptance and qualification tests.

**<5> Materials**

- a. The SCD-BSC shall include:
  1. Reference to the procurement specification of the supplier.
  2. For silicon solar cells, the following characteristics of the cells:
    - (a) growth technique;
    - (b) doping element;
    - (c) orientation;
    - (d) main breakage direction;
    - (e) base resistivity;
    - (f) thickness;
    - (g) for ARC: materials;
    - (h) for metal contact materials and thickness.
  3. For single and multi-junction III-V solar cells, the following characteristics of the cells:
    - (a) substrate material, orientation and thickness;
    - (b) doping element of the substrate;
    - (c) substrate resistivity;
    - (d) for each sub-cell: materials,
    - (e) for ARC: materials;
    - (f) for metal contact materials and thickness.

**<6> Acceptance tests****<6.1> Visual inspection.**

- a. In conformance with clause 7.5.1.5.4, the SCD-BSC shall list the maximum visible semiconductor length at the corners, in mm.

**<6.2> Dimensions and weight**

- a. In conformance with clause 7.5.2, the SCD-BSC shall include:
1. The dimensions shown in Figure C-1 to Figure C-3 including tolerances.
  2. The measurement method used to perform the test.
  3. The interval of the thickness of the silicon layer, in  $\mu\text{m}$ , for silicon solar cells.
  4. The interval of the thickness of the substrate with epi-layers, in  $\mu\text{m}$ , for III-IV cells.
  5. The maximum weight, in mg, of the average shipment lot.

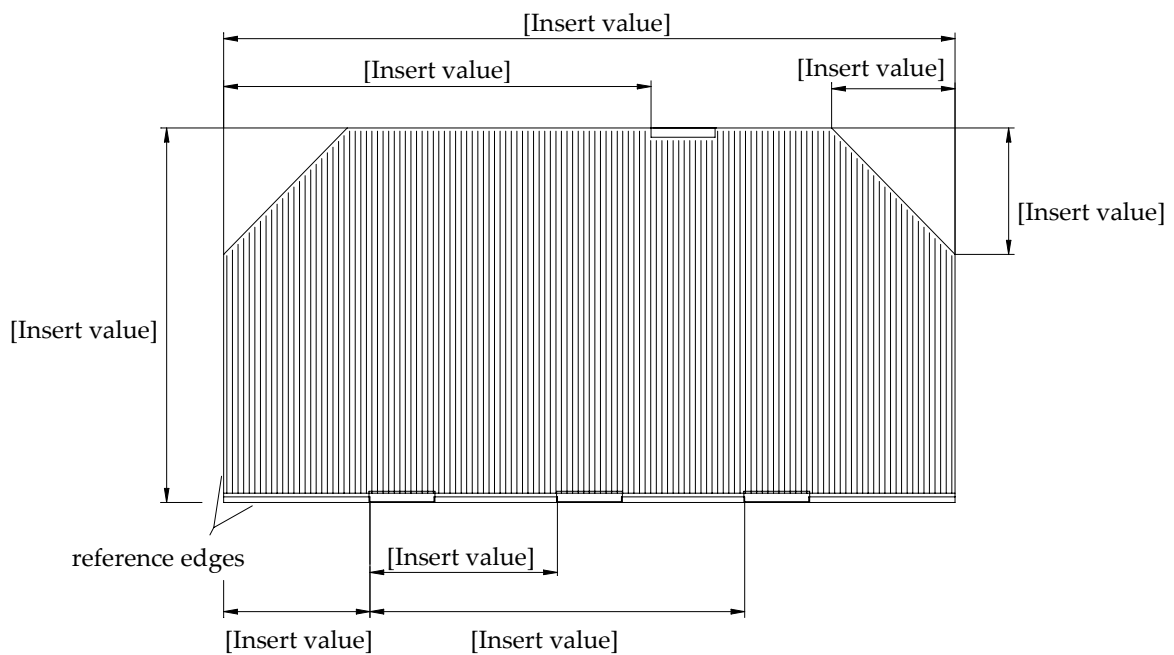

**Figure C-1: BSC front side**

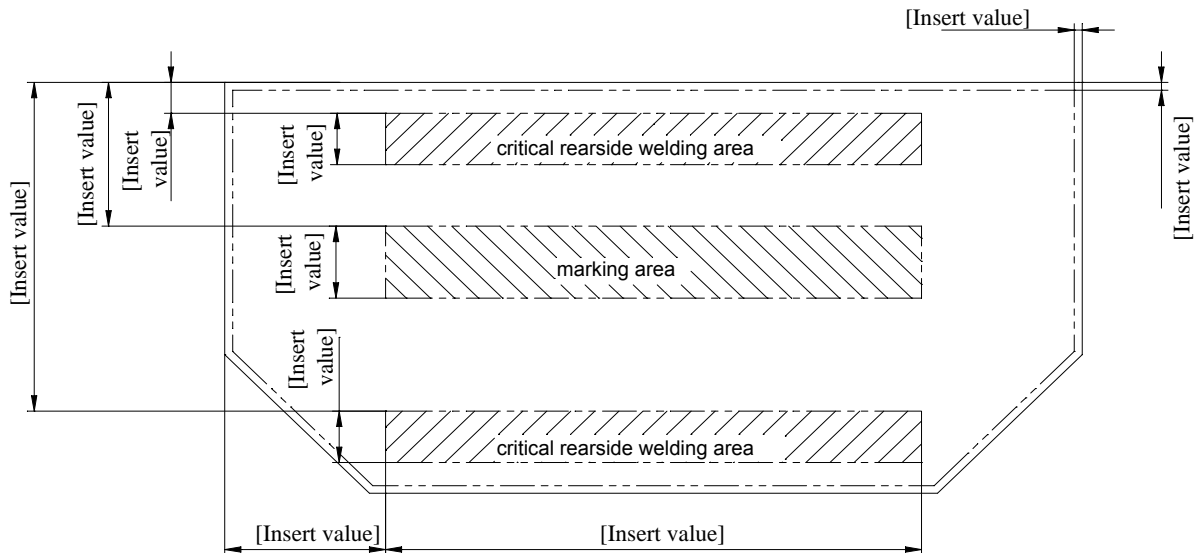

**Figure C-2: BSC rear side**

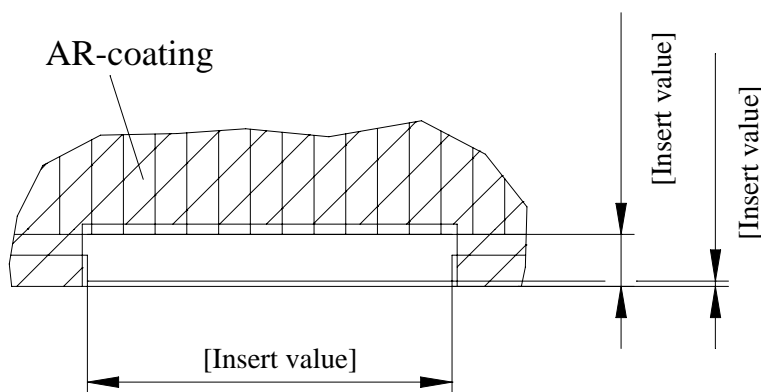

**Figure C-3: BSC contact**

**<6.3> Contact uniformity**

- a. In conformance with clause 7.5.10, the SCD-BSC shall include:
  1. The equipment to measure the contact thickness;
  2. The maximum and minimum values of the contact thickness in  $\mu\text{m}$ .

**<6.4> Surface finish**

- a. In conformance with clause 7.5.11, the SCD-BSC shall include the maximum value of the surface finish ( $R_z$ ) in  $\mu\text{m}$ .

**<6.5> Electrical performance**

- a. In conformance with clause 7.3.2.2.2, the SCD-BSC shall include the following test conditions:

1. the  $V_{test}$ , in mV;
  2. the temperature, in °C;
  3. the cells used as reference and their traceability to primary standards.
- b. In conformance with clause 7.3.2.2.3 for the pass-fail criteria, the following requirements shall be included:
1. the minimum value for  $I_{test}$ , in mA;
  2. the average value for  $I_{test}$ , in mA;
- c. In conformance with clause 7.3.2.2.4 the SCD-BSC shall include the intervals in mA for electrical grading

#### <6.6> Hemispherical reflectance

- a. In conformance with clause 7.5.6.2, the SCD-BSC shall include the interval of reflectance for silicon BSR cells, at 1,5  $\mu\text{m}$ , as a percentage (%).

#### <6.7> Humidity and temperature

- a. In conformance with clause 7.5.7.2.2, the SCD-BSC shall include the chemical contents (type and % in the mist) to be added to the humid environment when there are specific requirements on the contents of the environment.

#### <6.8> Pull

- a. In conformance with clause 7.5.12, the SCD-BSC shall include:
1. the interconnection technique parameter;
  2. the material and dimension of the interconnectors;
  3. the value of the pull speed in mm/min;
  4. the value of the ultimate pull strength in N;
  5. the pull direction (0°, 45° or 90°).

#### <6.9> Integral diode performance

- a. In conformance with clause 9.4.5.2, the SCD-BSC shall include for cells with protection diode electrically isolated from the cell:
1. For the test specified in requirement 9.4.5.2.2b:
    - (a) the temperature,
    - (b) the forward current,
    - (c) the reverse voltage.
  2. The pass-fail criteria for the test specified in clause 9.4.5.2.3:
    - (a) the maximum absolute value of the forward voltage in V;
    - (b) the reverse current in mA.



**<6.10> Cell coverglass gain-loss**

- a. In conformance with clause 7.5.6.3, the SCD-BSC shall include:
1. the agent used to simulate the properties of the adhesive;
  2. the coverglass used for the test;
  3. for the test conditions, the temperature, in °C;
  4. for the pass-fail criteria, the maximum  $I_{sc}$ , in %.

**<7> Qualification**

**<7.1> Visual inspection**

- a. The SCD-BSC shall include the same provisions as in the visual inspection for the acceptance tests (in conformance with clause C.2.1<6.1>).

**<7.2> Dimensions and weight**

- a. The SCD-BSC shall include the same provisions as in the dimensions and weight for the acceptance tests (in conformance with clause C.2.1<6.2>).

**<7.3> Electrical performance**

- a. In conformance with clause 7.5.3.2, the SCD-BSC shall include the pass-fail values shown in Table C-1, for
1. the individual solar cells, and
  2. the minimum average.

**Table C-1: Electrical performance pass-fail criteria**

Parameter	BOL	Remaining Factors (at 25 °C)		
		EOL([Insert value]) (particles/cm <sup>2</sup> ) <sup>a</sup> )	EOL([Insert value]) (particles/cm <sup>2</sup> ) <sup>a</sup> )	EOL([Insert value]) (particles/cm <sup>2</sup> ) <sup>a</sup> )
		Ratio	Ratio	Ratio
V <sub>OC</sub> [mV]	[Insert value]	[Insert value]	[Insert value]	[Insert value]
I <sub>SC</sub> [mA/cm <sup>2</sup> ]	[Insert value]	[Insert value]	[Insert value]	[Insert value]
V <sub>MAX</sub> [mV]	[Insert value]	[Insert value]	[Insert value]	[Insert value]
I <sub>MAX</sub> [mA/cm <sup>2</sup> ]	[Insert value]	[Insert value]	[Insert value]	[Insert value]
P <sub>MAX</sub> [mW/cm <sup>2</sup> ]	[Insert value]	[Insert value]	[Insert value]	[Insert value]
I <sub>(V<sub>t</sub>)</sub> [mA]	[Insert value]	[Insert value]	[Insert value]	[Insert value]

a) particles are electrons or protons after photon irradiation and temperature annealing

**<7.4> Spectral response**

- a. If the method using narrow band interference filters the SCD-BSC shall include (in conformance with requirement 7.5.5.2b.1(c) for multi-junction

GaAs solar cells the number of narrow band interference filters and their wavelength.

#### <7.5> **Optical properties**

- a. Hemispherical reflectance
  1. The SCD-BSC shall include the same provisions as in the hemispherical reflectance for acceptance tests (in conformance with clause C.2.1<6.6>).
- b. Coverglass gain-loss
  1. The SCD-BSC shall include the same provisions as in the coverglass gain-loss for acceptance tests (in conformance with clause C.2.1<6.10>).

#### <7.6> **Humidity and temperature**

- a. The SCD-BSC shall include the same provisions as in the humidity and temperature for acceptance tests (in conformance with clause C.2.1<6.7>).

#### <7.7> **Contact uniformity**

- a. In conformance with clause 7.5.9, the SCD-BSC shall include
  1. the equipment to measure the contact thickness;
  2. the requirements of the interconnection process to uniformity of the contact.

NOTE Example: maximum and minimum values of the contact thickness in  $\mu\text{m}$ .

#### <7.8> **Surface finish**

- a. The SCD-BSC shall include the same provisions as in the surface finish for acceptance tests (in conformance with clause C.2.1<6.4>).

#### <7.9> **Pull**

- a. The SCD-BSC shall include the same provisions as in the pull test for acceptance tests (in conformance with clause C.2.1<6.8>).

#### <7.10> **Electron irradiation**

- a. In conformance with clause 7.5.13.2, the SCD-BSC shall include:
  1. For general characterization of solar cells, the dosages at 1 MeV, in  $\text{e}^- \text{cm}^{-2}$ .
  2. For mission specific qualification, the expected dose for the envisaged application,  $\Phi_p$ , at 1MeV, in  $\text{e}^- \text{cm}^{-2}$ .
  3. The electron irradiation at transfer orbit dose at 1MeV, in  $\text{e}^- \text{cm}^{-2}$ , when specified by the mission requirements.

#### <7.11> **Proton irradiation**

- a. In conformance with clause 7.5.14.2, the SCD-BSC shall include:

1. The two energies to which cells of subgroup P are irradiated ( $X_1$  and  $X_2$  in MeV);
2. For each of the two energies defined in C.2.1<7.11> a.1, the flux in  $p^+ \text{ cm}^{-2} \text{ s}^{-2}$ .

#### <7.12> Solar cell reverse bias

- a. In conformance with clause 7.5.16.2, the SCD-BSC shall include
  1. the parameters of reverse IV characteristics measurement, such as test temperature in °C, hold time in s, current limitation in mA and maximum reverse bias in V
  2. the pass/fail criteria

NOTE Example: maximum allowed difference in  $I_{op}$  before and after test.

#### <7.13> Integral diode

- a. In conformance with clause 9.6, the SCD-BSC shall include for cells with integral protection diode electrically isolated from the cell:
  1. for burn in (in conformance with clause 9.6.5): the junction temperature of the diode at which burn in is to be performed
  2. for diode characterization the same provisions as in the diode characterization for the acceptance tests (in conformance with clause C.2.1<6.9>)
  3. for ESD (in conformance with clause 9.6.16.3): the pass fail criteria
  4. for switching test (in conformance with requirement 9.6.17.2f): the test conditions and pass fail criteria for level 1 and 2
  5. for life test (in conformance with requirement 9.6.18.2e): the total number of reverse bias and forward bias test steps, and the  $I_{rev}$ ,  $I_{fw}$  and  $V_{fw}$ .

#### <7.14> Thermal cycling

- a. In conformance with clause 7.5.17, the SCD-BSC shall include the number of thermal cycles to be performed before pull test on subgroup A and after humidity and temperature test in subgroup O, and their extreme temperatures.

#### <7.15> Active-passive interface evaluation

- a. In conformance with clause 7.5.18, the SCD-BSC shall include:
  1. The deviation of total energy in the spectral region of 0,8  $\mu\text{m}$  to 1,1  $\mu\text{m}$  as a percentage, using a non-infrared rich solar simulator.
  2. The maximum delta in  $V_{oc}$  of the cell under both solar simulator conditions (1 S.C. (AM0) and non-infrared rich).

#### <7.16> Flatness

- a. In conformance with clause 7.5.19, the SCD-BSC shall include:

1. The measurement method used to determine the flatness.
2. The minimum flatness, as the maximum value of deflection, in mm.

### **C.2.2 Special remarks**

None.

---

# Annex D (normative)

## Source control drawing for coverglass (SCD-CVG) - DRD

---

### D.1 DRD identification

#### D.1.1 Requirement identification and source document

This DRD is called from ECSS-E-ST-20-08, requirement clause 8.3.1.2b.

#### D.1.2 Purpose and objective

The source control drawing for coverglass (SCD-CVG) contains the specific project dependent requirements, and together with this Standard, which contains the general requirements, constitutes the whole set of requirements for the qualification and acceptance of coverglass.

The SCD-CVG can be produced as a standalone document or as part of a system-level specification document.

The information on traceability to high level requirements can be included in the SCD-CVG itself or in the requirements traceability in the design justification file (DJF, see ECSS-E-ST-10). In either case a cross-reference is made.

The SCD-CVG is a major input to the qualification plan.

### D.2 Expected response

#### D.2.1 Scope and content

##### <1> Introduction

- a. The SCD-CVG shall contain a description of the purpose, objective, content and the reason prompting its preparation.

##### <2> Applicable and reference documents

- a. The SCD-CVG shall list the applicable and reference documents to support the generation of the document.

**<3> Terms and definitions, abbreviated terms and symbols**

- a. The SCD-CVG shall include any additional definition, abbreviation or symbol used.

**<4> Deviations from ECSS-E-ST-20-08**

- a. In conformance with requirement 8.3.1.2c., the SCD-CVG shall include the justification for any deviation in the in-process, acceptance and qualification tests.

**<5> Materials**

- a. The SCD-CVG shall include the following coverglass materials characteristics:
1. Coverglass base material, including doping elements and percentage (%).
  2. Front surface coatings (including conductive coatings).
  3. Rear surface coatings.

**<6> Marking (coating orientation)**

- a. In conformance with clause 8.3.3, the SCD-CVG shall include a figure defining the coating orientation method for coverglass front surface coating identification.

NOTE This figure can be the same as the one mentioned in clause D.2.1<8.4>.

**<7> Acceptance tests****<7.1> Sample size for acceptance**

- a. In conformance with requirement 8.5.1b, the SCD-CVG shall include the sample size for acceptance.

**<7.2> Transmission into air**

- a. The SCD-CVG shall include the same provisions as for the transmission into air for qualification tests (in conformance with clause D.2.1<8.3>).

**<7.3> Dimensions, weight and thickness**

- a. The SCD-CVG shall include the same provisions as for the mechanical properties for the qualification tests (in conformance with D.2.1<8.5> a1, 2 and 3).

**<7.4> Visual inspection**

- a. The SCD-CVG shall include the same provisions as for the visual inspection for qualification tests (in conformance with clause D.2.1<8.1>).

**<7.5> Humidity and temperature HT2**

- a. In conformance with clause 8.7.11.2, the SCD-CVG shall state the chemical contents (type and percentage (%) in the mist) of the humid environment when there are specific requirements on the contents of the environment.

**<7.6> Thermal cycling**

- a. The SCD-CVG shall include the same provisions as for the thermal cycling for qualification tests (in conformance with clause D.2.1<8>).

**<8> Qualification tests**

**<8.1> Qualification test samples**

- a. In conformance with clause 8.6.2.2, the SCD-CVG shall include the number of the first production batches from which the coverglass qualification set is obtained.

**<8.2> Visual inspection**

- a. In conformance with clause 8.7.1.2, the SCD-CVG shall include:
  1. The maximum dimensions, in mm, of scratches and digs.
  2. The maximum number of corner chips per coverglass.

**<8.3> Transmission into air**

- a. Before the test the SCD-CVG shall include the transmission values shown in Table D-1.
- b. After the test the SCD-CVG shall include the transmission values shown in Table D-2.

**Table D-1: Average transmission into air before test (%)**

Discrete wavelength (nm)				Wavelength range (nm)				
400	450	500	600	300-320	400 - 450	600 - 800	450 - 1100	900 - 1800
[Insert value]	[Insert value]	[Insert value]	[Insert value]	[Insert value]	[Insert value]	[Insert value]	[Insert value]	[Insert value]

**Table D-2: Maximum average deviation of transmission into air after test (%)**

	Discrete Wavelength (nm)				Wavelength Range (nm)				
	400	450	500	600	300 - 320	400 - 450	600 - 800	450 - 1100	900- 1800
Environmental									
Boiling water	[insert value]	[insert value]	[insert value]	[insert value]	[insert value]	[insert value]	[insert value]	[insert value]	[insert value]
Humidity and temperature HT1	[insert value]	[insert value]	[insert value]	[insert value]	[insert value]	[insert value]	[insert value]	[insert value]	[insert value]
Thermal cycling	[insert value]	[insert value]	[insert value]	[insert value]	[insert value]	[insert value]	[insert value]	[insert value]	[insert value]
UV exposure	[insert value]	[insert value]	[insert value]	[insert value]	[insert value]	[insert value]	[insert value]	[insert value]	[insert value]
Electron irradiation	[insert value]	[insert value]	[insert value]	[insert value]	[insert value]	[insert value]	[insert value]	[insert value]	[insert value]
Proton irradiation	[insert value]	[insert value]	[insert value]	[insert value]	[insert value]	[insert value]	[insert value]	[insert value]	[insert value]

**<8.4> Electro-optical properties**

- a. In conformance with clause 8.7.3, the SCD-CVG shall include a figure showing the nominal values and tolerances for the following electro-optical properties:
1. bulk resistivity and surface resistivity;
  2. refractive index.

**<8.5> Mechanical properties**

- a. In conformance with clause 8.7.4, the SCD-CVG shall include a figure showing the nominal values and tolerances of the following mechanical properties:
1. dimensions (A: length, B: width);
  2. weight (average per shipping lot);
  3. density
  4. thickness;
  5. edge parallelism;
  6. perpendicularity of sides.

NOTE This figure can be the same as in clause D.2.1<8.4>.

**<8.6> Reflectance properties**

- a. In conformance with clause 8.7.5, the SCD-CVG shall include a figure showing the nominal values and tolerances of the following reflectance properties:
1. reflectance (including wavelength);



2. reflectance cut-on;
3. reflectance cut-off;
4. reflectance bandwidth.

NOTE This figure can be the same as in clause D.2.1<8.4>.

#### <8.7> Normal emittance

- a. In conformance with clause 8.7.6, the SCD-CVG shall include the minimum value of the normal emittance, as a percentage (%) and the equipment used to measure the normal emittance.

#### <8.8> Surface resistivity

- a. In conformance with clause 8.7.7, the SCD-CVG shall include the minimum value of the surface resistivity, in  $\Omega/\text{cm}^2$ , and the equipment used to measure the resistivity.

#### <8.9> Flatness or bow

- a. In conformance with clause 8.7.8, the SCD-CVG shall include:
  1. The minimum value of the flatness or bow, as a maximum deviation, in mm.
  2. The maximum value of coverglass displacement, from an optically flat surface over a specified distance in mm, for localized flatness deformations, in mm.

#### <8.10> Transmission into adhesive

- a. In conformance with clause 8.7.9, the SCD-CVG shall include:
  1. The values as shown in Table D-1.
  2. The Fresnel's equation used for the correction of the transmission for reflectance losses including all parameters.

#### <8.11> HT1 humidity and temperature

- a. In conformance with clause 8.7.11.1, the SCD-CVG shall state the chemical contents (type and percentage (%) in the mist) of the humid environment when there are specific requirements on the contents of the environment.

#### <8.12> Electron irradiation

- a. In conformance with clause 8.7.13.2, the SCD-CVG shall state the value of the nominal dose of the electron irradiation, in  $\text{e}^- \text{cm}^{-2}$ , and maximum rate, in  $\text{e}^- \text{cm}^{-2} \text{s}^{-1}$ .

#### <8.13> Proton irradiation

- a. In conformance with clause 8.7.14.2, the SCD-CVG shall state the value of the high and low energy dose of the proton irradiation in  $\text{p}^+ \text{cm}^{-2}$  and maximum flux, in  $\text{p}^+ \text{cm}^{-2} \text{s}^{-1}$ .

**<8.14> Breaking strength**

- a. In conformance with clause 8.7.15, the SCD-CVG shall state the method to be used to test for the breaking strength and the limits of the breaking strength, in N.

**<8.15> Thermal cycling**

- a. In conformance with clause 8.7.16, the SCD-CVG shall state the number of thermal cycles to be performed before contact adhesion and their extreme temperatures.

**D.2.2 Special remarks**

None.

# Annex E (normative)

## Source control drawing for External Protection Diodes (SCD-EPD) - DRD

---

### E.1 DRD identification

#### E.1.1 Requirement identification and source document

This DRD is called from ECSS-E-ST-20-08, requirement 9.2.1.2.2b.

#### E.1.2 Purpose and objective

The source control drawing for external protection diodes (SCD-EPD) contains the specific project dependent requirements, and together with this Standard, which contains the general requirements, constitutes the whole set of requirements for the qualification and acceptance of external protection diodes.

The SCD-EPD can be produced as a standalone document or as part of a system-level specification document.

The information on traceability to high level requirements can be included in the SCD-EPD itself or in the requirements traceability in the design justification file (DJF, see ECSS-E-ST-10). In either case a cross-reference is made.

The SCD-EPD is a major input to the qualification plan.

### E.2 Expected response

#### E.2.1 Scope and content

##### <1> Introduction

- a. The SCD-EPD shall contain a description of the purpose, objective, content and the reason prompting its preparation.

##### <2> Applicable and reference documents

- a. The SCD-EPD shall list the applicable and reference documents to support the generation of the document.

**<3> Terms and definitions, abbreviated terms and symbols**

- a. The SCD-EPD shall include any additional definition, abbreviation or symbol used.

**<4> Deviations from ECSS-E-ST-20-08**

- a. In conformance with requirement 9.2.1.2.2d, the SCD-EPD shall include the justification for any deviation in the in-process, acceptance and qualification tests.

**<5> Materials**

- a. The SCD-EPD shall include:
  1. Reference to the procurement specification of the supplier.
  2. The following characteristics of the external protection diodes:
    - (a) growth technique;
    - (b) doping element;
    - (c) orientation;
    - (d) main breakage direction;
    - (e) base resistivity;
    - (f) thickness.

**<6> Acceptance tests**

- a. In conformance with 9.4.1.e, the SCD-EPD shall include the sample size.
- b. For dimensions and weigh, in conformance with clause 9.6.3, the SCD-EPD shall include:
  1. The lateral dimensions and thickness, including tolerances.
  2. The contact dimensions, including tolerances.
  3. The maximum weight, in mg.
- c. For contact thickness, in conformance with clause 9.6.8, the SCD-EPD shall include the maximum and minimum values of the contact thickness in  $\mu\text{m}$ .
- d. For surface finish, in conformance with clause 9.6.9.3, the SCD-EPD shall include the requirements for the interconnection process.
- e. For humidity and temperature, in conformance with clause 9.6.6., the SCD-EPD shall include the chemical contents (type and % in the mist) to be added to the humid environment when there are specific requirements on the contents of the environment.
- f. For Pull, in conformance with clause 9.6.11, the SCD-EPD shall include:
  1. the interconnection technique parameter;
  2. the material and dimension of the interconnectors;

3. the value of the pull speed in mm/min and direction (0°, 45° or 90°);
  4. the value of the ultimate pull strength in N.
- g. For diode performance, in conformance with clause 9.4.5.2 the SCD-EPD shall include:
1. For the test conditions specified in clause 9.4.5.2.2:
    - (a) the temperature,
    - (b) the forward current level ,
    - (c) the reverse voltage level.
  2. The pass-fail criteria for the test specified in clause 9.4.5.2.3:
    - (a) the maximum absolute value of the forward voltage in V;
    - (b) the reverse current in mA;

## <7> Qualification

### <7.1> Qualification test samples

- a. In conformance with requirement 9.5.4.2b, the SCD-EPD shall include:
1. The minimum number of protection diodes from which the qualification lot shall be selected.
  2. The number of the first production batches from which the qualification lot is obtained.

### <7.2> Dimensions and weight

- a. In conformance with clause 9.6.3, the SCD-EPD shall include:
1. The lateral dimensions and thickness, including tolerances.
  2. The contact dimensions, including tolerances.
  3. The maximum weight, in mg.

### <7.3> Diode characteristics

- a. In conformance with clause 9.6.15.2, the SCD-EPD shall include:
1. For the test conditions:
    - (a) the temperatures,
    - (b) the times,
    - (c) the forward current level,
    - (d) the reverse voltage level.
  2. The pass-fail criteria for the test specified in clause 9.6.15.3:
    - (a) the maximum absolute value of the forward voltage in V;
    - (b) the reverse current in mA.

### <7.4> Thermal cycling

- a. In conformance with clause 9.6.4.2, the SCD-EPD shall include the number of thermal cycles and their extreme temperatures.

**<7.5> Burn-in**

- a. In conformance with clause 9.6.5.2, the SCD-EPD shall include the temperature of the burning process

**<7.6> Humidity and temperature**

- a. In conformance with clause 9.6.6, the SCD-EPD shall include the chemical contents (type and % in the mist) to be added to the humid environment when there are specific requirements on the contents of the environment.

**<7.7> Contact uniformity.**

- a. In conformance with clause 9.6.7.3, the SCD-EPD shall include the maximum and minimum values of the contact thickness in  $\mu\text{m}$ .

**<7.8> Surface finish.**

- a. In conformance with clause 9.6.9.3, the SCD-EPD shall include the requirements for the interconnection process.

**<7.9> Pull**

- a. In conformance with clause 9.6.11, the SCD-EPD shall include:
  1. the interconnection technique parameter;
  2. the material and dimension of the interconnectors;
  3. the value of the pull speed in mm/min and direction ( $0^\circ$ ,  $45^\circ$  or  $90^\circ$ );
  4. the value of the ultimate pull strength in N.

**<7.10> Electron irradiation**

- a. In conformance with clause 9.6.12.2, the SCD-EPD shall include the expected total dose for the envisaged application,  $\Phi_p$ , at 1MeV, in  $\text{e}^- \text{cm}^{-2}$ .

**<7.11> Switching:**

- a. In conformance with requirement 9.6.17.2f, the SCD-EPD shall include:
  1. For level 1: The voltage ( $V_{\text{REV}}$ ), current ( $I_{\text{fw}}$ ), times ( $T_1$ ,  $T_2$  and  $T_3$ ) and temperatures.
  2. For level 2: The voltage ( $V_{\text{REV}}$ ), current ( $I_{\text{fw}}$ ), times ( $T_1$ ,  $T_2$  and  $T_3$ ) and temperatures.

**<7.12> Life Testing:**

- a. In conformance with requirement 9.6.18.2e, the SCD-EPD shall include the total number of test steps in reverse and forward bias mode and the  $I_{\text{rev}}$ ,  $I_{\text{fw}}$  and  $V_{\text{fw}}$ .

**E.2.2 Special remarks**

None.

# Annex F (normative)

## Process identification document (PID) - DRD

---

### F.1 DRD identification

#### F.1.1 Requirement identification and source document

This DRD is called from ECSS-E-ST-20-08, requirements 6.2a, 7.2a, 8.4a and 9.3.2a.

#### F.1.2 Purpose and objective

The purpose of the PID is to have a complete set of documentation defining the traceability of materials, processes and test results of the relevant components or sub-assemblies.

### F.2 Expected response

#### F.2.1 Scope and content

- a. The PID shall comprise copies of the definition documents of the SCA, and the manufacturing documents and testing procedures, and include the following:
  1. in the case of SCAs, a parts list;
  2. a materials list;
  3. a list of all manufacturing drawings;
  4. the production flow chart;
  5. the specifications for the process used;
  6. procedures for the inspection performed;
  7. the overall test programme (including in-process tests and acceptance tests);
  8. a table of contents with reference number and issue;
  9. the test matrix for acceptance tests, including requirements and failure criteria;

10. the traceability details of the component.

NOTE The traceability details are as agreed between customer and supplier.

### **F.2.2 Special remarks**

- a. When a document is company confidential or contains proprietary information, the complete document need not be included.
- b. In the case specified in requirement 11.2.2.4a, a reference to the document shall be included.



# Annex G (normative)

## Data documentation package (DDP) - DRD

---

### G.1 DRD identification

#### G.1.1 Requirement identification and source document

This DRD is called from ECSS-E-ST-20-08, requirement 5.7a, 6.6a, 7.7a, 8.9a and 9.8a.

#### G.1.2 Purpose and objective

The DDP is the collection of the data related to the manufacturing, integration and test of the PVA, SCA, BSC, CVG and protection diode, which provides traceability and events records, and is the basis to support the acceptance and qualification of the PVA, SCA, BSC, CVG and protection diode.

### G.2 Expected response for PVA DDP

#### G.2.1 Scope and content

- a. The PVA-DDP of coupons for the delivery review board (DRB) shall include, as a minimum, the following items:
  1. table of contents;
  2. certificate of conformance;
  3. shipping documents;
  4. configuration item data list (CIDL);
  5. product manufacturing and control file (PMCF);
  6. parts, materials and processes (PMP) list;
  7. list of requests for deviations;
  8. list of requests for waivers;
  9. list of nonconformances, including copies of nonconformance reports (NCRs) NRB documentation including failure analysis and failed coupon list;
  10. history record;
  11. connector mate and de-mate record;
  12. serialized components list;
  13. in-process inspection test results, including positioning in the manufacturing flow chart;
  14. open work or open test;

15. replacement or temporary installation record;
16. acceptance and qualification test procedures and test reports;
17. assembly drawings and circuit diagram;
18. notes and comments;
19. operation and maintenance manuals and user restrictions;
20. minutes of delivery review board (DRB) meetings;
21. lower level data documentation packages (DDPs).

### **G.2.2 Special remarks**

None.

## **G.3 Expected response for SCA, BSC, CVG, and Protection diode DDP.**

### **G.3.1 Scope and content**

- a. The DDP for SCA, BSC, CVG and protection diode shall consist of cover sheet or sheets, including as a minimum the following:
  1. reference to the corresponding SCD, including issue and date;
  2. reference to this Standard, including issue and date;
  3. component type (for SCDs, BSCs, coverglasses and protection diodes);
  4. procurement SCA, BSC, CVG and protection diode identification;
  5. manufacturing SCA, BSC, CVG and protection diode identification;
  6. number of purchase order or contract;
  7. deviations from, or additions to, the corresponding SCD and this Standard, if so specified in the order;
  8. manufacturer's name and address;
  9. location of the manufacturing plant;
  10. signature on behalf of the manufacturer;
  11. total number of pages of the data package.
- b. The DDP for SCA, BSC, CVG and protection diode shall consist of the summary compilation of the final production test data, showing:
  1. For SCAs, the total number of SCAs submitted to, and the total number rejected after, each of the following tests:
    - (a) Visual inspection,
    - (b) Control of dimensions,
    - (c) Electrical performance measurements,
    - (d) Diode performance measurements.
  2. For BSC, coverglasses and protection diodes, the total number of elements submitted to, and the total number rejected after, each of the acceptance tests.

- c. The DDP for SCA, BSC, CVG and protection diode shall consist of the qualification testing data, including:
  - 1. For SCAs BSCs, and protection diodes, detailed data of all measurements made in conformance with:
    - (a) Table B-1 and Figure 6-2 (SCAs),
    - (b) Annex C (BSCs),
    - (c) Annex C (IPD) or Annex E (EPD).
  - 2. data of all environmental tests
- d. The DDP for SCA, BSC, CVG and protection diode shall consist of failed SCAs, BSCs, CVGs and EPDs list and the corresponding non conformance reports , including:
  - 1. The reference number and description of the test or measurement as stated in this Standard or in the corresponding SCD.
  - 2. The identification of failed component (for SCDs, BSCs, coverglasses and protection diodes).
  - 3. The failed parameter and the failure mode of the component (for SCDs, BSCs, coverglasses and protection diodes).
  - 4. A detailed failure analysis report.
- e. The DDP for SCA, BSC, CVG and protection diode shall consist of certificate of compliance.
- f. The DDP for SCA, BSC, CVG and protection diode shall consist of full request of deviations and waivers.
- g. The DDP for SCA, BSC, CVG and protection diode shall consist of qualification test plan.
- h. The DDP for SCA, BSC, CVG and protection diode shall consist of acceptance and qualification test reports.

### **G.3.2 Special remarks**

- a. For identification purposes, each page of the data package shall include the following additional supporting data:
  - 1. component type (for SCDs, BSCs, coverglasses and protection diodes);
  - 2. manufacturer's name;
  - 3. manufacturing lot identification (for SCDs, BSCs, coverglasses and protection diodes);
  - 4. date of establishment of the document;
  - 5. page number.

---

## Bibliography

---

ECSS-E-ST-00	ECSS system – Description, implementation and general requirements
ECSS-E-ST-10	Space engineering – System engineering
ECSS-E-ST-20-06	Space engineering – Spacecraft charging
ECSS-Q-ST-10-09	Space product assurance – Nonconformance control system
ECSS-Q-ST-20-07	Space product assurance – Quality assurance for test centres
ECSS-Q-ST-30	Space product assurance – Dependability
ECSS-Q-ST-30-02	Space product assurance – Failure modes, effect and criticality analysis (FMECA)
ECSS-Q-ST-30-11	Space product assurance – EEE components – Derating and end-of-life parameter drifts
ECSS-Q-ST-70	Space product assurance – Materials, mechanical parts and processes
ECSS-Q-ST-70-02	Space product assurance – Thermal vacuum outgassing test for the screening of space materials
ECSS-Q-ST-70-08	Space product assurance – Manual soldering of high-reliability electrical connections
ECSS-Q-ST-70-13	Space product assurance – Measurement of the peel and pull-off strength of coating and finishes using pressure-sensitive tapes
ECSS-Q-ST-70-26	Space product assurance – Crimping of high-reliability electrical connections
ESA-PSS-01-202	Preservation, storage, handling and transportation of ESA spacecraft hardware
EN 1939	Self adhesive tapes - Determination of peel adhesion properties
ISO 2859	Sampling procedures for inspection by attributes
ISO 9211-4	Optics and optical instruments -- Optical coatings -- Part 4: Specific test methods
ISO 23038	Space systems – Space solar cells – Electron and proton irradiation test methods
MIL-M-13508	Mirror, Front Surfaced Aluminized: for Optical Elements
MIL-PRF 13830	General specification governing the manufacture, assembly and inspection of optical components for fire control instruments