

Space product assurance

**Determination of the susceptibility of
silver-plated copper wire and cable
to “red-plague” corrosion**

Published by: ESA Publications Division
ESTEC, P.O. Box 299,
2200 AG Noordwijk,
The Netherlands

ISSN: 1028-396X

Price: € 10

Printed in The Netherlands

Copyright 2000 © by the European Space Agency for the members of ECSS

Foreword

This Standard is one of the series of ECSS Standards intended to be applied together for the management, engineering and product assurance in space projects and applications. ECSS is a cooperative effort of the European Space Agency, national space agencies and European industry associations for the purpose of developing and maintaining common standards.

Requirements in this Standard are defined in terms of what shall be accomplished, rather than in terms of how to organize and perform the necessary work. This allows existing organizational structures and methods to be applied where they are effective, and for the structures and methods to evolve as necessary without rewriting the standards.

This Standard has been prepared by editing ESA PSS-01-720, reviewed by the ECSS Technical Panel and approved by the ECSS Steering Board.

(This page is intentionally left blank)

Contents

Foreword	3
Introduction	7
1 Scope	9
2 Normative references	11
3 Terms, definitions and abbreviated terms	13
3.1 Terms and definitions	13
3.2 Abbreviated terms	13
4 Preparatory conditions	15
4.1 Hazards, health and safety precautions	15
4.2 Handling and storage	15
4.3 Identification	15
4.4 Test equipment	15
5 Test procedure	17
5.1 Preparation of test samples	17

5.2	Test sequence	18
5.3	Test duration	18
6	Acceptance criteria	21
6.1	Inspection of sample	21
6.2	Acceptance and rejection criteria	22
7	Quality assurance	23
7.1	General	23
7.2	Data	23
7.3	Nonconformance	23
7.4	Calibration	23
7.5	Traceability	23
	Annex A (normative) Codes for extent of corrosion	25
	Annex B (informative) Example of a “Red-plague test report sheet”	33
	Bibliography	35

Figures

Figure 1: Sketch of prepared test cable	18
Figure 2: Example of test equipment	19
Figure A-1: Extent of Corrosion (per 20 cm length/test sample); Code 0	26
Figure A-2: Extent of Corrosion (per 20 cm length/test sample); Code 1	27
Figure A-3: Extent of Corrosion (per 20 cm length/test sample); Code 2	28
Figure A-4: Extent of Corrosion (per 20 cm length/test sample); Code 3	29
Figure A-5: Extent of Corrosion (per 20 cm length/test sample); Code 4	30
Figure A-6: Extent of Corrosion (per 20 cm length/test sample); Code 5	31

Tables

Table 1: Corrosion classification	22
---	----

Introduction

Silver-plated copper conductors are suitable for general spacecraft use, but it is essential that the plating is of uniform thickness of at least $2\ \mu\text{m}$. Localized damage due to wire or cable fabrication processes (e.g. stranding, braiding, application of insulation jackets) can result in spots in the plating where the thickness is less than $1\ \mu\text{m}$. Wire strands supporting silver platings less than $1\ \mu\text{m}$ thick are susceptible to red-plague corrosion.

The deleterious effects to be anticipated as a result of testing wires and cables to the requirements of this Standard, which is accelerated by means of oxygen, high humidity and elevated temperature, include corrosion of all defective silver-plated conductor materials and shielding braid or the strands of internal conductors.

Silver-plated copper wires or cables that are tested and successfully pass the acceptance criteria as defined in this Standard are considered not to suffer from degradation by red-plague corrosion during ten-year controlled storage periods and normal spacecraft service lifetimes.

(This page is intentionally left blank)

Scope

This Standard gives details of an accelerated screening test method to determine the suitability of silver-plated wire and cable materials for use on spacecraft and associated equipment. The test method, which also determines the suitability of the associated fabrication processes, is based on the work of Anthony and Brown (1965). They established that “red-plague” originates at breaks in the silver-plating of copper wire strands in the presence of moisture and oxygen. The environmental test system artificially promotes “red-plague” corrosion under controlled laboratory conditions as a result of galvanic corrosion of the copper conductor core.

(This page is intentionally left blank)

Normative references

The following normative documents contain provisions which, through reference in this text, constitute provisions of this ECSS Standard. For dated references, subsequent amendments to, or revisions of any of these publications do not apply. However, parties to agreements based on this ECSS Standard are encouraged to investigate the possibility of applying the most recent editions of the normative documents indicated below. For undated references the latest edition of the publication referred to applies.

ECSS-P-001	Glossary of terms
ECSS-Q-20	Space product assurance — Policy and principles
ECSS-Q-20-09	Space product assurance — Nonconformance control system
ECSS-Q-70	Space product assurance — Materials, mechanical parts and processes

(This page is intentionally left blank)

Terms, definitions and abbreviated terms

3.1 Terms and definitions

The following terms and definitions are specific to this Standard in the sense that they are complementary or additional to those contained in ECSS-P-001.

3.1.1

batch

quantity produced at one operation

NOTE One batch can be subdivided into several lots.

3.1.2

corrosion

deterioration of a metal by chemical or electrochemical reaction with its environment

3.1.3

red-plague

red-coloured cuprous oxide (possibly with some black cupric oxide) corrosion product that forms when a galvanic cell is formed between copper and silver; the presence of humidity or moisture is a prerequisite.

3.2 Abbreviated terms

The abbreviated terms defined in ECSS-P-001 apply.

(This page is intentionally left blank)

Preparatory conditions

4.1 Hazards, health and safety precautions

Particular attention shall be paid to health and safety precautions. Moreover, hazards to personnel or materials shall be controlled and minimized.

4.2 Handling and storage

Samples of wires and cables shall only be handled with clean nylon or lint-free gloves. Before and after testing they shall be stored in a clean area.

4.3 Identification

Wires and cables submitted for testing shall be accompanied by a material identification sheet. The samples shall, as a minimum, be identified by:

- a. Trade name, source, manufacturer's code number, batch number and date of manufacture.
- b. Construction details of wires or cables including form, principal dimensions, description of insulation materials and conductor materials, plating materials and their nominal thicknesses.

4.4 Test equipment

For this test method, the following test equipment shall be used:

- a. Microscope. At least $\times 20$ magnification with attachment to enable photomicrographs to be taken.
- b. Conical glass flasks (Erlenmeyer > 250 ml)
- c. Natural rubber stoppers (two holed)
- d. Glass tubing (3 mm - 6 mm internal diameter)
- e. Supply of oxygen gas
- f. Gas flow regulator (e.g. Hoffman clips)
- g. Stock of deionized water
- h. Length of copper wire 1 mm - 2 mm diameter
- i. Water trough, or other suitable temperature-control bath
- j. Temperature regulator/heater
- k. Thermometers

- l. Scalpel and wire cutters that produce a shear 90° end cut
- m. Any additional equipment enabling metallurgical analysis to be performed when called up by subclause 6.1 d.

Test procedure

5.1 Preparation of test samples

- a. The wire or cable to be submitted to this test procedure shall be taken from stock with minimum handling. Any particles or contamination visible on the outer insulation under a magnification of $\times 10$ shall be removed with a clean, lint-free cloth. For further handling of the wire or cable, clean nylon or lint-free cloth gloves shall be worn.
- b. Two adjacent test samples shall be cut from the mid-length of the submitted wire or cable. Each test sample shall have a length of (200 ± 50) mm. Cutting tools shall produce a shear 90° cut.
- c. One test sample shall be stripped of insulation and the exposed (silver-)plated braid or strands visually inspected for corrosion and contamination at a magnification of $\times 20$. In the case of shielded cable, all inner conductors shall be removed, stripped of insulation and inspected. Any unusual features such as contamination or corrosion products present on the exposed (silver-)plated strands shall be photographed and used for a control reference.
- d. The second test sample shall be prepared for the corrosion test. The outer insulation jacket shall be partially removed using a sharp scalpel blade. Incisions may be circumferential or longitudinal, but shall not damage the metal conductors. The length of outer insulation to be removed shall be (20 ± 5) mm from the sample end as shown in Figure 1. When inner conductors are present, the outer braid shall be splayed to give clear exposure of the cut ends of all inner strands. Sharp cutters may be used to trim the inner conductors to ensure that the insulation has not sealed off those wires.

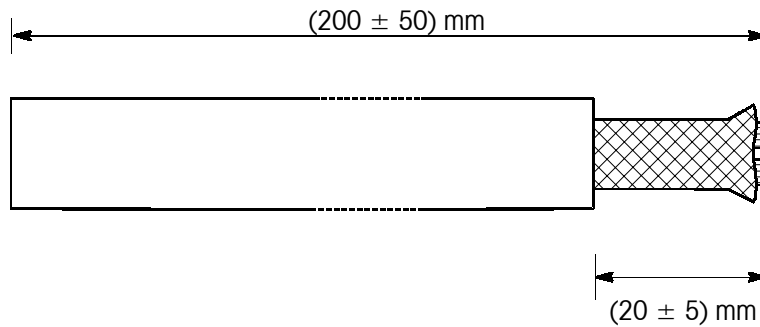

Drawing not to scale

Figure 1: Sketch of prepared test cable

5.2 Test sequence

- 200 ml of deionized water shall be poured into the clean glass flask. The wire or cable sample shall be inserted into one hole of the two-hole stopper. This shall be held in place with a short length of copper wire. A glass tube shall be inserted into the second hole. This is shown in Figure 2.
- The stopper shall be fitted into the neck of the flask, together with a short length of copper wire to provide for an air gap between flask and stopper.
- The glass tube shall extend into the deionized water. The end of the wire or cable sample shall be located at a distance of (20 ± 5) mm from the water surface. A supply of oxygen shall be connected to the glass tube with plastic tubing, and a Hoffman clip, or other regulator, controls the passage of oxygen into the water to maintain a flow rate of (50 ± 10) bubbles per minute.
- The test flask shall be placed in a water trough or bath maintained at a temperature of (58 ± 2) °C. Water can be prevented from evaporating from the trough by a covering of any suitable material (e.g. expanded polystyrene).
- Only one wire or cable sample shall be tested per flask. If more than one test is performed at the same time, the flasks and oxygen flow shall be placed in parallel to each other.

5.3 Test duration

The wire or cable sample shall be exposed for a duration of 240 hours (10 days), after which it shall be removed from the flask and stopper.

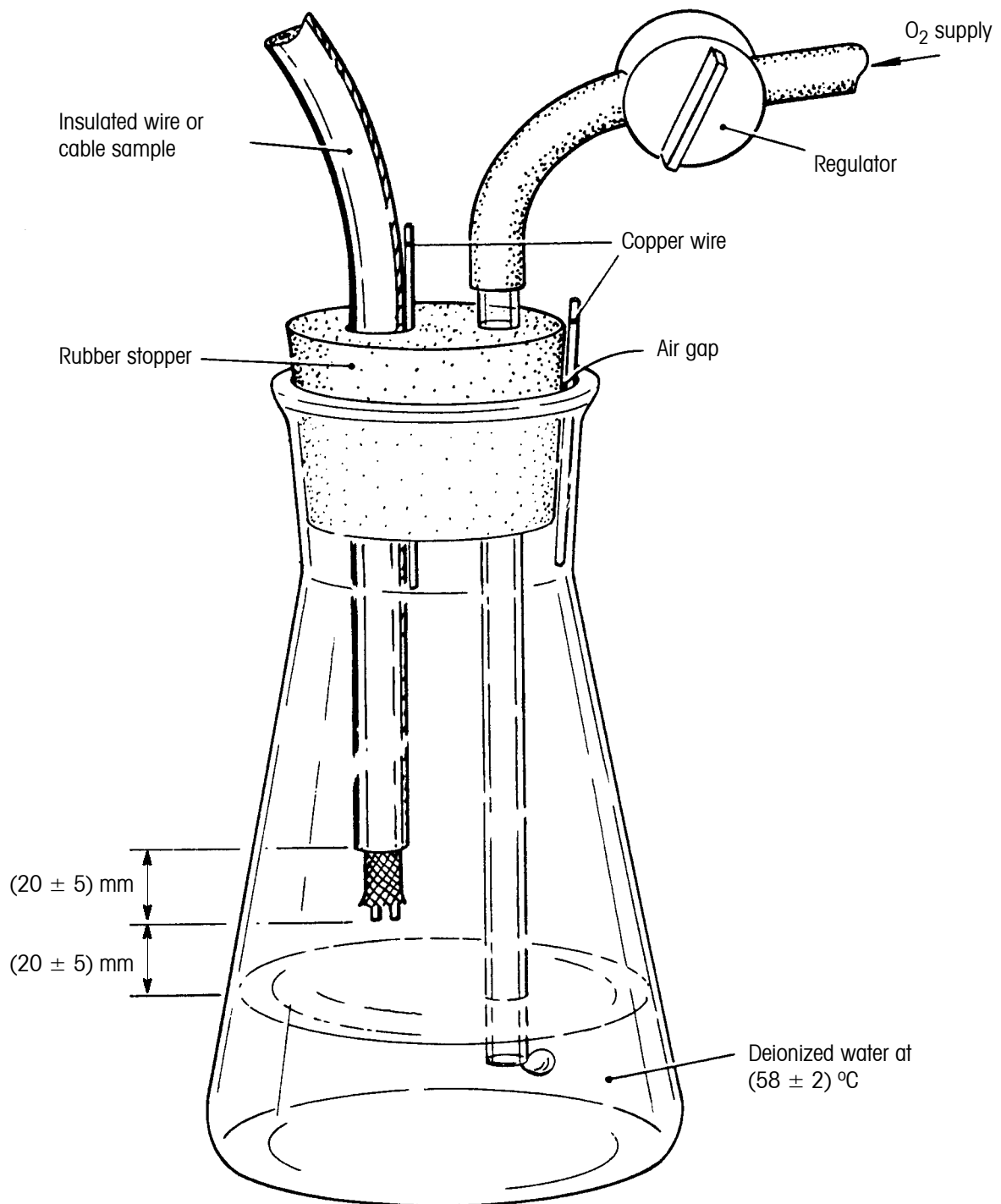

Figure 2: Example of test equipment

(This page is intentionally left blank)

Acceptance criteria

6.1 Inspection of sample

- a. The sample shall be inspected within three hours of being removed from the test apparatus. All insulation shall be removed from the outer braid (when present) and at least one of the inner conductors.
- b. The silver-plated strands that make up braiding or inner conductor shall be inspected at a magnification of $\times 20$ for signs of contamination and corrosion. Specific areas of interest should be photographed.
- c. The extent of corrosion (per 20 cm length) present on the tested samples (comprising 19 wire strands) shall be graded, on the basis of subjective visual inspection results, in accordance with Table 1 (see also annex A).
For samples comprising 7 wire strands, 2 to 3 affected strands in one or a few locations along the sample length shall be considered a minor defect and corrosion affecting 4 or more strands (more than 50 %) shall be considered a major defect.
- d. Visual inspection as a means of quantifying the extent of corrosion in c. is subjective owing to the possibility of widespread precipitation of corrosion product onto adjacent strands. Conductors that have been designated a code of 4 or 5 shall be additionally evaluated by metallography to quantify the number of strands that bear corrosion sites.

Table 1: Corrosion classification

Code	Extent of corrosion (19-strand wire)	
0	None	
1	Minor defect:	One point on 1 or 2 adjacent strands.
2	Minor defect:	On 2 to 8 adjacent strands in one location along sample length.
3	Minor defect:	On 2 to 8 adjacent strands in a few locations along sample length.
4	Major defect:	On 2 to 10 adjacent strands in several locations along sample length.
5	Major defect:	Severe corrosion affecting more than 50 % of the total strands from any conductor, in any location.
Note: Codes 0 to 3 are considered not to affect the electrical properties of the wire or cable.		

6.2 Acceptance and rejection criteria

The codes 0 to 3, as defined in subclause 6.1 c. shall not be cause for failure of the test sample. For the cases when codes 4 and 5 are confirmed by additional investigation, defined in 6.1 d., the sample and associated batch of conductor material shall be rejected as being unsuitable for space use.

Quality assurance

7.1 General

The quality assurance requirements are defined in ECSS-Q-20.

7.2 Data

The quality records (e.g. logbooks) shall be retained for at least ten years or in accordance with project contract requirements, and contain as a minimum the following:

- a. the wire or cable identification data described in subclause 4.3;
- b. all inspection and test results;
- c. photomicrographs made during the investigations described in subclause 6.1 d.

Test results should be recorded on a standard sheet such as that illustrated in annex B.

7.3 Nonconformance

Any nonconformance that is observed in respect of the process shall be dispositioned in accordance with quality assurance requirements, see ECSS-Q-20-09.

7.4 Calibration

Each reference standard and piece of measuring equipment used for the test shall be calibrated. Any suspected or actual equipment failure shall be recorded as a project nonconformance report so that previous results can be examined to ascertain whether or not re-inspection and retesting is required. The customer shall be notified of the nonconformance details.

7.5 Traceability

Traceability shall be maintained throughout the process from incoming inspection to final test, including details of test equipment and personnel employed in performing the task.

(This page is intentionally left blank)

Annex A (normative)

Codes for extent of corrosion

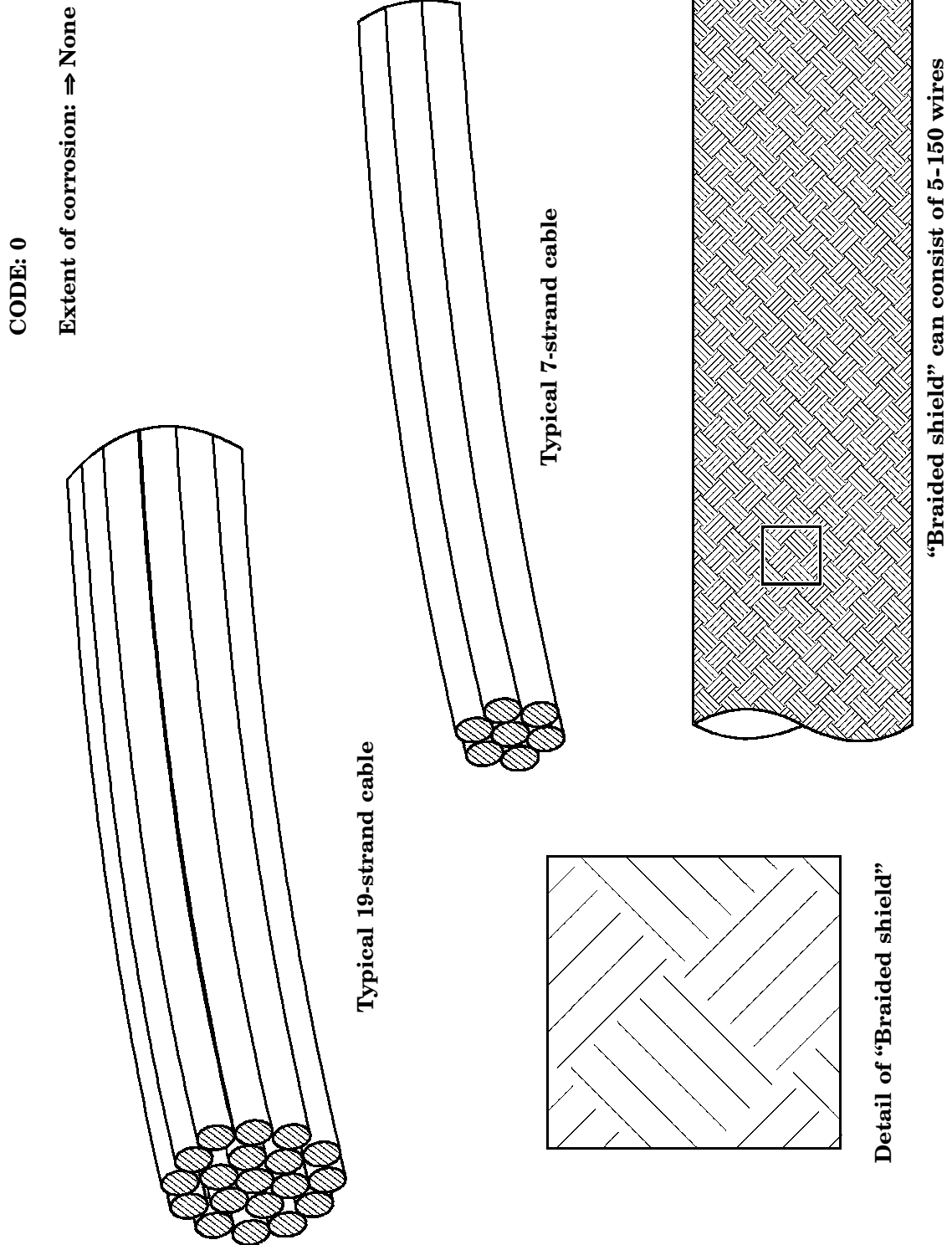

Figure A-1: Extent of Corrosion (per 20 cm length/test sample): Code 0

CODE: 1
Extent of corrosion: ⇒ Minor defect
One point on 1 or 2 adjacent strands

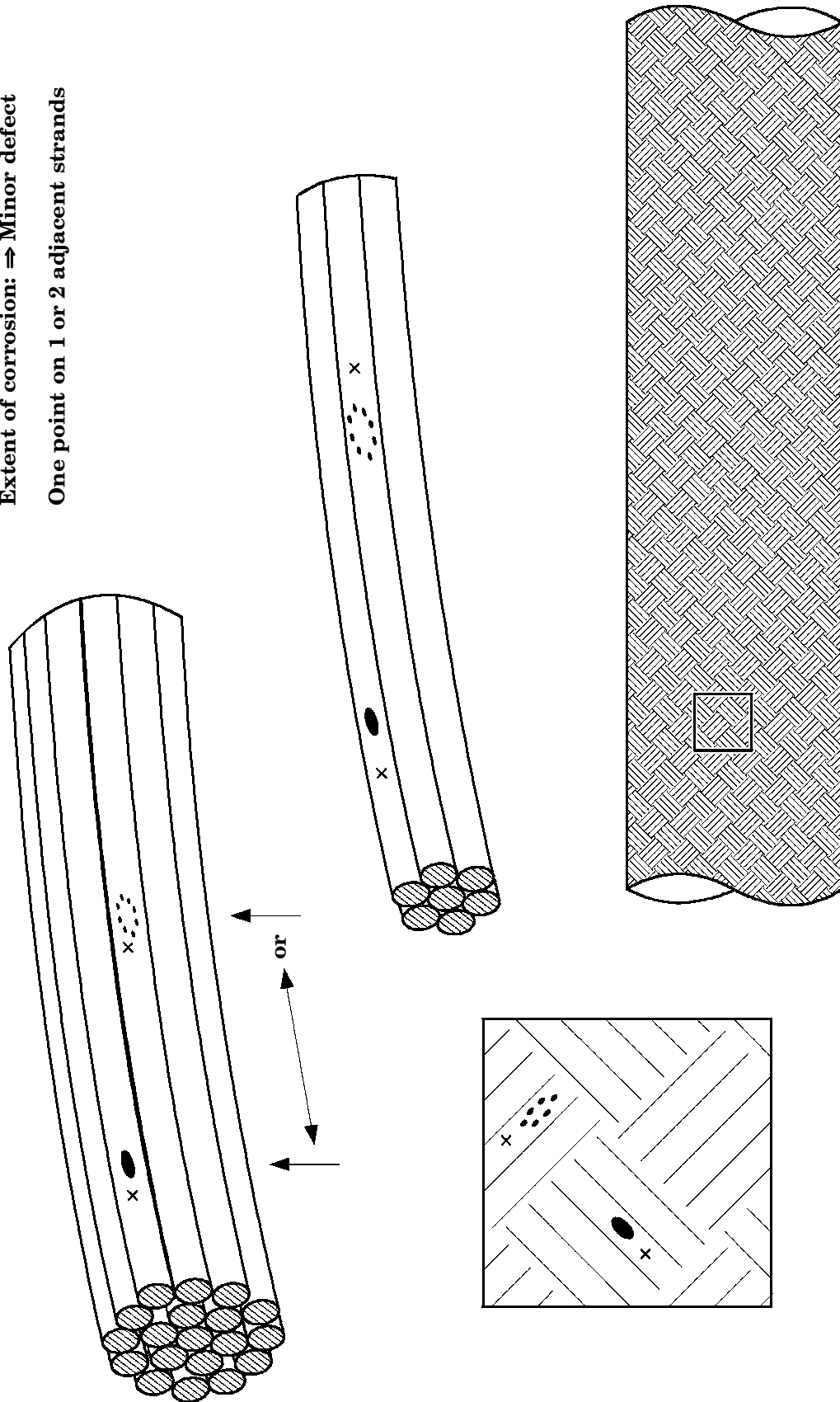

Figure A-2: Extent of Corrosion (per 20 cm length/test sample): Code 1

CODE: 2

Extent of corrosion: ⇒ Minor defect

**On 2 to 8 adjacent strands in one location
along sample length.
(On 2 to 3 adjacent strands for samples
with 7 strands)**

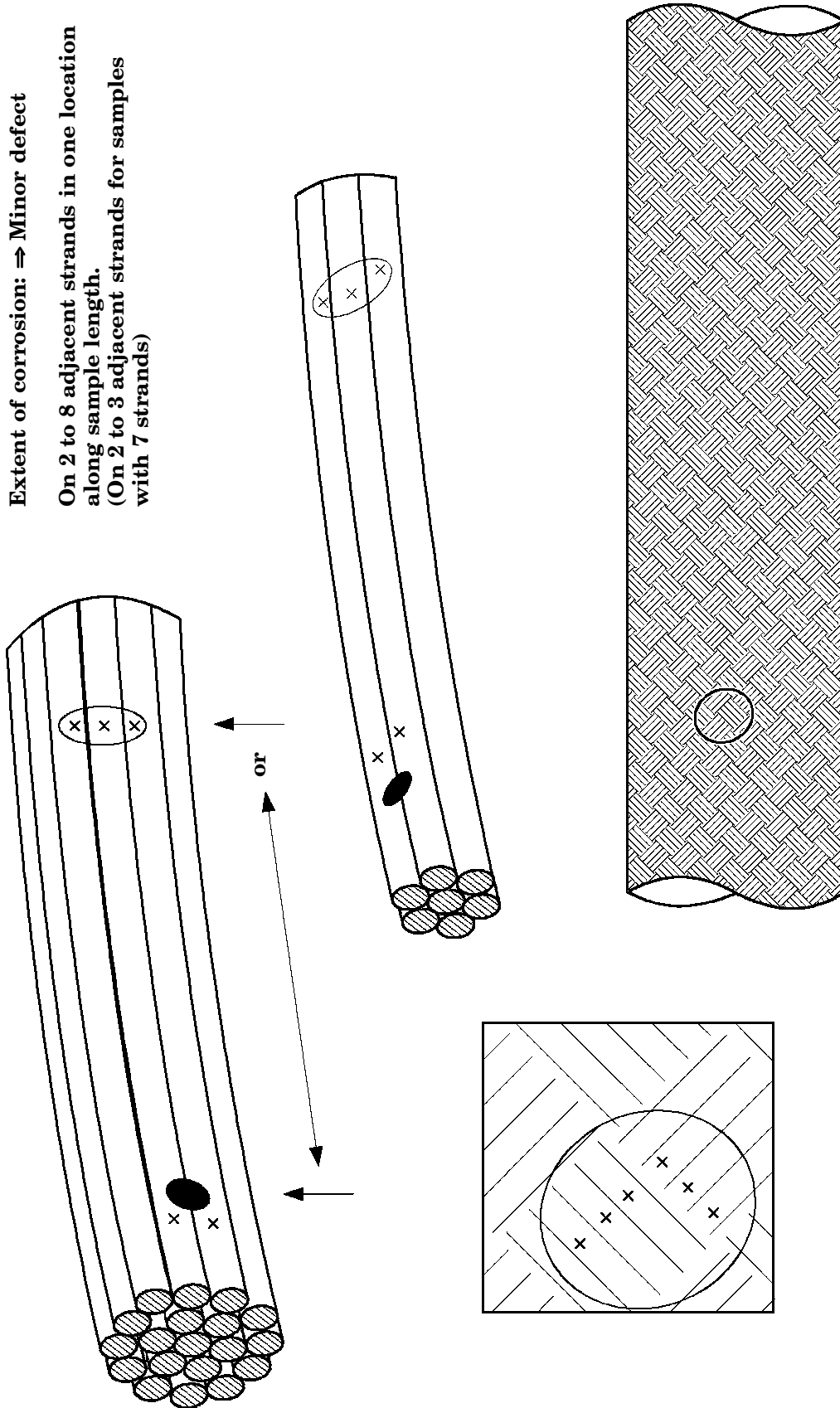

Figure A-3: Extent of Corrosion (per 20 cm length/test sample): Code 2

CODE: 3

Extent of corrosion: ⇒ Minor defect

**On 2 to 8 adjacent strands in a few locations along sample length.
(On 2 to 3 adjacent strands for samples with 7 strands)**

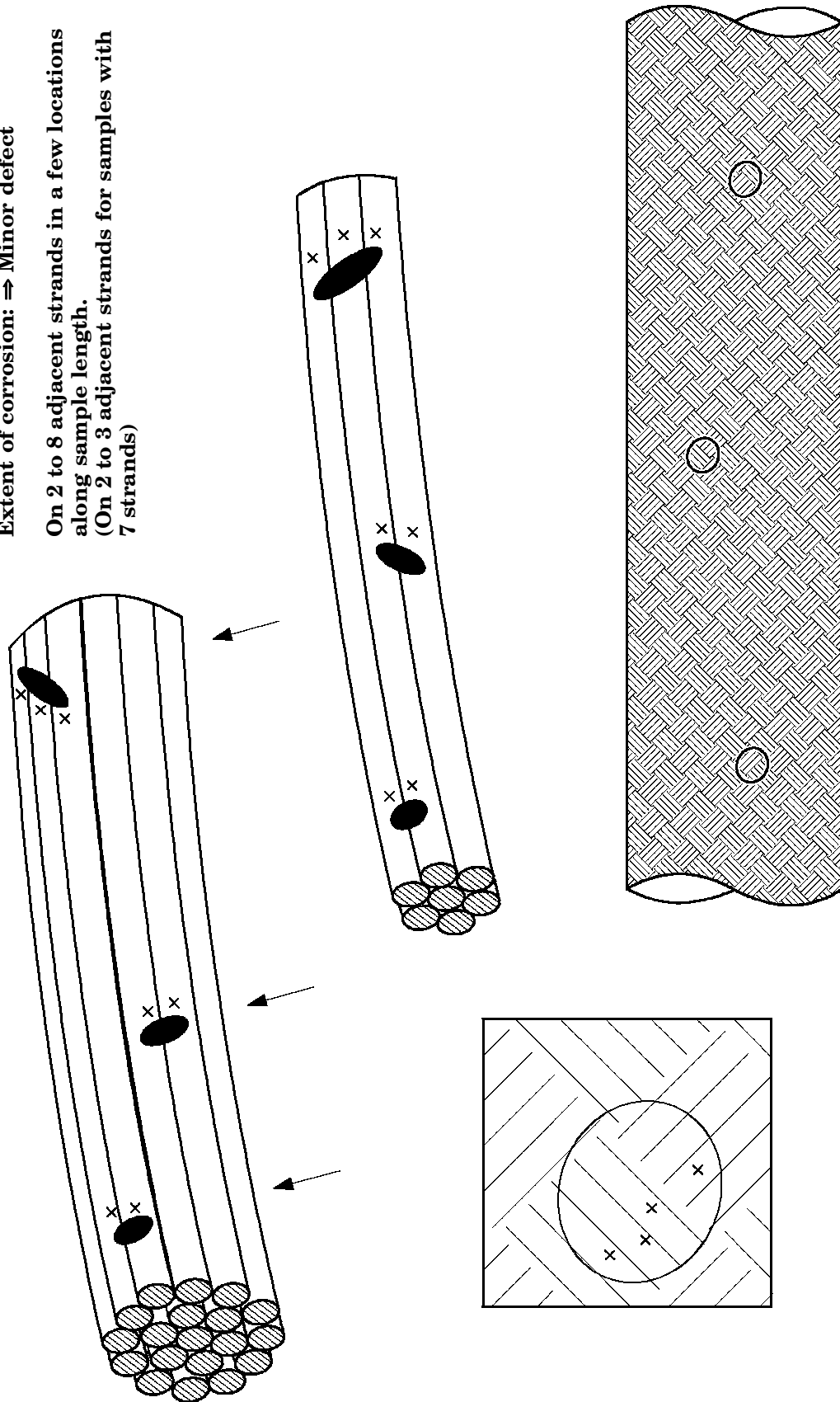

Figure A-4: Extent of Corrosion (per 20 cm length/test sample): Code 3

CODE: 5

Extent of corrosion: ⇒ Major defect

Severe corrosion affecting more than 50 % of the total strands from any conductor in any one location

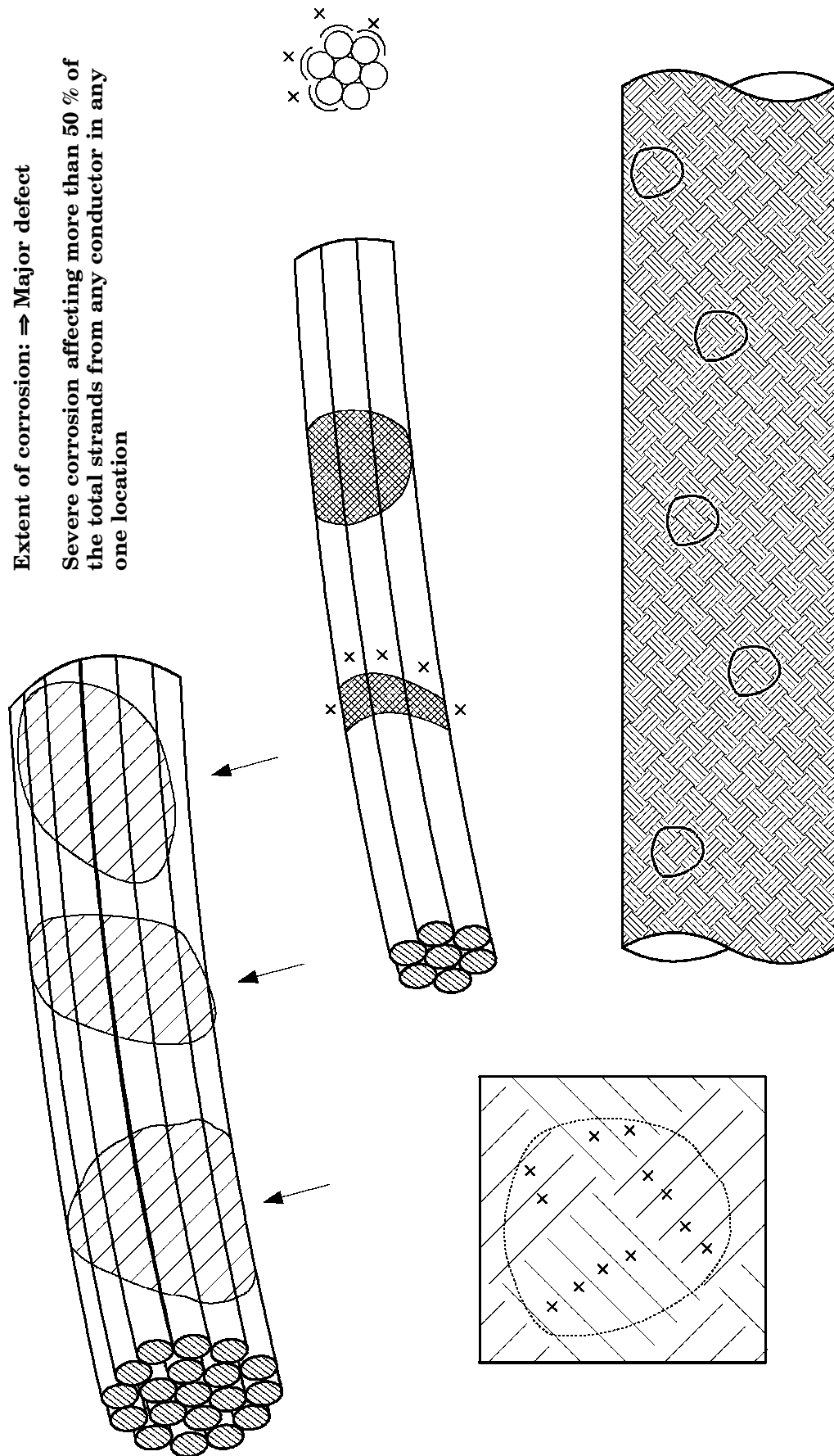

Figure A-6: Extent of Corrosion (per 20 cm length/test sample): Code 5

(This page is intentionally left blank)

Annex B (informative)

Example of a “Red-plague test report sheet”

Red-plague test report sheet					
Test number	Wire or cable designation	Inspection results		Date of text completion	Signature of inspector
		Sample 1 (as received)	Sample 2 (following 10-day test)		
		Extent of corrosion (see 6.1), additional discrepancies, metallography results and observations (e.g. a. Braid, b. Inner braid, c. Inner conductor)			

Bibliography

Mater. Prot. Performance, March 1965 Vol. 4 No. 3 “Red-plaque corrosion on silver plated wire” by Anthony P.L. and Brown O.M.

(This page is intentionally left blank)

(This page is intentionally left blank)