



Space product assurance

Crimping of high-reliability electrical connections

Published by: ESA Publications Division
ESTEC, P.O. Box 299,
2200 AG Noordwijk,
The Netherlands

ISSN: 1028-396X

Price: € 10

Printed in The Netherlands

Copyright 2001 © by the European Space Agency for the members of ECSS

Foreword

This Standard is one of the series of ECSS Standards intended to be applied together for the management, engineering and product assurance in space projects and applications. ECSS is a cooperative effort of the European Space Agency, national space agencies and European industry associations for the purpose of developing and maintaining common standards.

Requirements in this Standard are defined in terms of what shall be accomplished, rather than in terms of how to organize and perform the necessary work.

This Standard has been prepared by editing ESA PSS 01-726, reviewed by the ECSS Technical Panel and approved by the ECSS Steering Board.

(This page is intentionally left blank)

Contents

Foreword	3
Introduction	9
1 Scope	11
2 Normative references	13
3 Terms, definitions and abbreviated terms	15
3.1 Terms and definitions	15
3.2 Abbreviated terms	15
4 Preparatory conditions	17
4.1 Hazards, health and safety precautions	17
4.2 Configuration of process and workpiece	17
4.3 Facilities	18
4.4 Tools and equipment	18

5	Crimping operations	21
5.1	Forms of crimp	21
5.2	Workmanship	22
5.3	Workmanship standards	28
6	Test method	29
6.1	General	29
6.2	Voltage-drop	29
6.3	Tensile strength	30
6.4	Metallography	32
7	Acceptance criteria	33
7.1	Validation and qualification testing	33
7.2	Shift performance test	34
8	Quality assurance	35
8.1	General	35
8.2	Data	35
8.3	Nonconformance	35
8.4	Calibration of crimping tools	37
8.5	Requirements for new crimp configurations	38
8.6	Traceability	39
8.7	Personnel training	39
8.8	Inspections	40

Figures

Figure 1: Confined irregular-octagon crimp (compactive)	21
Figure 2: Dimpled confined octagon crimp (compactive)	21
Figure 3: Regular-hexagon crimp (compactive)	22
Figure 4: Semicircular one- or two-indent crimp (dispersive)	22
Figure 5: Four-indent crimp (dispersive)	22
Figure 6: Example of a typical connector barrel and single wire crimping	23
Figure 7: Example of a typical connector barrel and multi-wire crimping	25
Figure 8: Example of a typical ferrule shield crimping	26
Figure 9: Typical test fixture for testing lug and splice crimps	27
Figure 10: Examples of typical lug and splice wire crimping	27
Figure 11: Workmanship examples and crimp microsections	28

Figure 12: Measurement of voltage-drop across a crimped termination	29
Figure 13: Guide to quality controls during crimping operation	36
Figure 14: Typical plots showing variation in crimp termination characteristics with increasing indentation depth	39

Tables

Table 1: Guideline for selector setting — Four-indent crimp (dispersive) Single wire — Crimping tool 22520/2-01	24
Table 2: Guideline for selector setting — Four-indent crimp (dispersive) Two wires — Crimping tool 22520/2-01	25
Table 3: Guideline for die selection (ferrule coaxial shield crimping)	26
Table 4: Voltage-drop test requirements	30
Table 5: Required ultimate axial strength for compactive and dispersive crimped joints	31

(This page is intentionally left blank)

Introduction

This Standard defines customer requirements and quality assurance provisions for crimping wire terminations intended for high-reliability electrical connections. These terminations include removable contacts, coaxial connectors, ferrules, lugs and splices which are crimped to wire conductors and other electrical or electronic components for use on customer spacecraft and associated equipment operating under high vacuum, thermal cycling and vibration.

(This page is intentionally left blank)

Scope

The methods used for preparing and assembling the parts to be joined by crimping, and the selection, calibration, use and verification of the crimping tools are part of this Standard.

Only tested and qualified crimp interconnections are covered by this Standard. In view of the large variety of crimp technologies, the different forms of crimps have been listed (not exhaustively) in subclause 5.1.

Training and certification requirements for operators and inspectors are defined in subclause 8.7 and in ECSS-Q-20.

(This page is intentionally left blank)

Normative references

The following normative documents contain provisions which, through reference in this text, constitute provisions of this ECSS Standard. For dated references, subsequent amendments to, or revisions of any of these publications do not apply. However, parties to agreements based on this ECSS Standard are encouraged to investigate the possibility of applying the most recent editions of the normative documents indicated below. For undated references the latest edition of the publication referred to applies.

ECSS-P-001	Glossary of terms
ECSS-Q-20	Space product assurance — Quality assurance
ECSS-Q-20-09	Space product assurance — Nonconformance control system
ECSS-Q-60	Space product assurance — Electrical, electronic and electromechanical (EEE) components
ECSS-Q-70	Space product assurance — Materials, mechanical parts and processes
ECSS-Q-70-08	Space product assurance — The manual soldering of high-reliability electrical connections
ECSS-Q-70-71 ¹⁾	Space product assurance — Data for selection of space materials
MIL-DTL-22520G	Crimping tools, terminal hard, wire termination, general specification for
NASA-STD-8739.4	Crimping, Interconnection cables, harnesses and wiring
SAE-AS-7928	Terminals, lugs, splices, conductor, crimp style, copper, general specification for
SAE-AS-81824	Splices, electric, permanent, crimp style, copper, insulated, environment resistant

1) To be published.

(This page is intentionally left blank)

Terms, definitions and abbreviated terms

3.1 Terms and definitions

The following terms and definitions are specific to this Standard in the sense that they are complementary or additional to those contained in ECSS-P-001.

3.1.1

adjustable indenter tool

crimping tool which has an adjustable part (setting variable) that indents or compresses the conductor barrel or ferrule

3.1.2

crimping tool

mechanical tool used for permanently attaching a wire termination device to a conductor by pressure deformation or by reshaping the barrel around the conductor to establish good electrical and mechanical contact

3.1.3

electrical connections

connections in electrical or electronic circuits

3.1.4

ferrule

short metal tube used to make crimp connections to the outer conductor of shielded or coaxial cables

3.1.5

lug

metallic tube with drilled flange projection for fixing to threaded terminal

3.1.6

splice

device for joining two or more conductors to each other

3.1.7

terminal

metallic device that is used for making electrical connections

3.2 Abbreviated terms

The following abbreviated terms are defined and used within this Standard.

Abbreviation	Meaning
AWG	American wire gauge
RH	relative humidity

Preparatory conditions

4.1 Hazards, health and safety precautions

Particular attention shall be paid to health and safety precautions.

- a. Hazards to personnel, equipment and materials shall be controlled and reduced to a minimum.
- b. Components, tools and controls shall be so located that personnel are not exposed to hazards such as electric shock, cutting edges, sharp points or toxic atmospheres.

4.2 Configuration of process and workpiece

4.2.1 General

In order to ensure conformance to customer requirements and as a means of identifying potential problems, the supplier shall perform a review of the materials, tools and techniques which he plans to use for the work. The review shall cover each separate manufacturing step and consider the type of wire (number of strands, plating metal, type and thickness of insulation), the type of terminal and the single die tools which are suited to perform the operation. Special attention shall be paid to the selection of dies and the setting of controls for the length of strip in automatic stripping machines as well as to the selection of specific locators or positioners, including size and tolerance, for crimping tools, whether power-driven or manual. The used tools, wires and contacts and the adjustment of the tools shall be documented on a drawing or in a control document. Also the type of positioner and number of selector which is used for the contacts shall be included in the documentation.

The cleaning and other treatment of the workpieces shall be according to those listed in ECSS-Q-70-08A, subclause 6.3.1. Further cleaning or other treatment shall not be carried out.

Workpieces shall be handled only with clean lint-free gloves or finger cots.

4.2.2 Wires and cables

Silver-plated copper multi-stranded wire and braided shield cable should be used in crimp-type connectors. Nickel- and tin-plated wire may only be used with special justification. The reasons are that this can present electrical problems (poor corrosion resistance when coupled to gold, and formation of intermetallics). Nickel plate gives increased resistance at elevated temperatures, and is not suit-

able for low voltages. Silver-plated copper wire is used for most applications when crimped interconnections are envisaged. Provisions shall be taken to avoid tarnish during storage and in instances when the same wire is also joined later by soldering, in order to avoid degradation of the crimp interface by corrosion, only the solder fluxes prescribed in ECSS-Q-70-08 shall be used.

Soft or annealed copper wire shall not be used for crimped joints of 26 AWG and 28 AWG size. Only high-strength copper-alloy wire shall be used for 26 AWG and 28 AWG crimped joints.

4.2.3 Terminals

- a. Space qualified components having gold-plated terminals shall be used (e.g. standard connector contact and coaxial contact) according to ECSS-Q-60.
- b. Specific terminals such as ferrules, splices and lugs should be purchased to MIL or SAE specification (e.g. SAE-AS-7928). When gold-plating is not available the finish shall be in accordance with ECSS-Q-70-71.
- c. Cadmium, chromate-coated cadmium and non-fused tin-plating shall not be used under any circumstances.

4.3 Facilities

4.3.1 Facility cleanliness

- a. Unless classified as a cleanroom, the areas in which crimping is carried out shall be maintained in a neat orderly fashion, with no loose material (e.g. dirt, dust, oils, clipped wires) that can cause contamination of the crimped connection. Furniture shall be kept to a minimum in the work areas and be arranged to allow easy and thorough cleaning of the floor.
- b. Working surfaces shall be covered with an easily cleaned hard top or have a replaceable surface of clean, non-corrosive silicone-free paper.
- c. Tools used in the crimping operation shall be clean; excess lubricants shall be removed before crimping starts.
- d. Before assembly, wire, terminal and connector contacts shall be visually examined for cleanliness, absence of oil films and freedom from tarnish or corrosion.

4.3.2 Environmental conditions

The crimping area shall have a controlled environment which limits entry of contamination. The area shall be continuously controlled as follows:

- room temperature: $(22 \pm 3) ^\circ\text{C}$;
- relative humidity: $(55 \pm 10) \%$.

The workstations shall not be exposed to draughts. Fresh air shall be supplied to the room through a filtering system so that there is a positive pressure difference with regard to adjacent rooms; the exhaust air shall be suitably restricted.

4.3.3 Lighting requirements

The light intensity shall be a minimum of 1080 lux on the work surface. At least 90 % of the work area shall be shadowless and without severe reflections.

4.4 Tools and equipment

4.4.1 Crimping tools

- a. Tools used shall employ some integral mechanism which controls the crimping operation to the extent that, once the operation is started, they cannot be opened until the crimping cycle is complete and in conformance to MIL-

- DTL-22520G unless otherwise agreed by the customer project requirements, (for general applications see 4.2.3 a. and for specific applications see 4.2.3 b.).
- b. Each tool shall be marked to show the size and type of termination for which it is calibrated.
 - c. Tool calibration shall be verified once each shift (see subclause 8.8.2).
 - d. Proper operation of the integral ratcheting mechanism or the positive stops on pneumatic tools shall be verified during the performance of the verification procedure, as defined in subclause 8.4.
 - e. Upon completion of crimping operations on a given size terminal and type of wire, the manual crimping tools shall be returned to the tool facility before the issue of a crimping tool calibrated for the size termination and type of wire called out for the next operation. If the seals are broken for any reason, the tool shall be returned immediately for recalibration.

4.4.2 Insulation strippers

a. Thermal strippers

Thermal-type insulation strippers may be used on types of wire insulation for which they are suited; they are preferred for use on 22 AWG and smaller wire sizes where there is a possibility of wire stretching if a mechanical stripper is used. The heat of the stripper shall be controlled to prevent blistering and excessive melting of insulation. Local extraction units shall be used if thermal stripping is employed, to avoid part contamination or health hazards due to resultant fumes.

b. Precision cutting-type strippers

Automatic power-driven strippers with precision, factory-set, non-adjustable cutting and stripping dies and wire guards may be used. Precision-type hand strippers with accurately machined and factory-preset cutting heads may be used with a caution about making certain that, when possible, the die openings for wire sizes other than that being used are masked off. The conductor shall not be twisted, ringed, nicked, cut or scored by this operation.

c. Calibration of stripping tools

Both thermal and mechanical stripping tools shall be calibrated periodically on sample evaluation during a production run.

4.4.3 Cutters and pliers

The cutter used for trimming conductor wire shall shear sharply and consistently produce a clean, flat, smooth-cut surface along the entire cutting edge. There shall be no twisting action during this cutting operation. The cutting edges of pliers shall be regularly checked for damage and maintained in a sharp condition. Smooth, long-nose pliers or tweezers may be used for attaching or removing conductor wire.

4.4.4 Test and monitoring equipment

For performance tests, the following test equipment shall be used (depending on wire gauge):

Voltage-drop (see 6.2):	0 A - 150 A current source and 0 mV - 10 mV voltmeter
Tensile strength (see 6.3):	Tensile testing machine 0 N - 4000 N, accurate to 1 % of full scale load
Indenters position (see 8.4.2):	Profile projector magnification $\times 20$ to $\times 50$
Visual inspection:	Microscope magnification $\times 7$ to $\times 400$

Suitable measuring equipment to fulfil the monitoring requirements of the process:

Temperature:	15 °C to 30 °C, accurate to ± 1 °C
Relative humidity (RH):	40 % to 70 %, accurate to ± 1 %

Crimping operations

5.1 Forms of crimp

Many crimp interconnection technologies are currently available for space applications. Confined or compactive crimps are made by a tool which exerts an even pressure around the receptacle barrel circumference such that even deformation is applied on all sides; the only means of stress relief is by elongation of the barrel and wire (see Figures 1 to 3).

Non-confined or dispersive crimps result from compression of the receptacle barrel with an indenter die having one or two indents or, alternatively, by two or four radially opposed indenter dies (see Figures 4 and 5).

Interconnections, not covered by this Standard, shall be the subject of a request for approval (RFA), according to ECSS-Q-70.

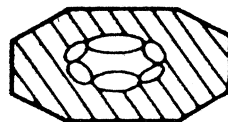

Figure 1: Confined irregular-octagon crimp (compactive)

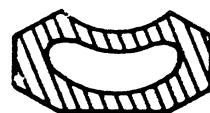

Figure 2: Dimpled confined octagon crimp (compactive)

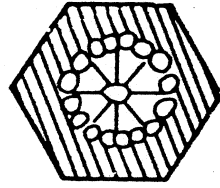

Figure 3: Regular-hexagon crimp (compactive)



Figure 4: Semicircular one- or two-indent crimp (dispersive)

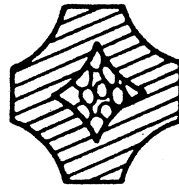

Figure 5: Four-indent crimp (dispersive)

5.2 Workmanship

5.2.1 General

The achievement of a good crimped joint is controlled to a large extent by the tools and materials used, but workmanship - the manner in which they are employed - is also important. Items that constitute workmanship are those under the control of the operator. They include careful butting of the wire against the stop in the stripping operation to ensure correct insulation gap, loading of a connector pin in the positioner to the full distance, inserting the stripped wire into the connector pin barrel until it shows in the inspection hole and re-twisting the strands not more than the natural lay, if disturbed during the stripping operation.

Clean lint-free gloves or finger cots shall be used for this operation.

All conductor strands shall be inserted cleanly into the barrel without any buckling. Strands shall not be left outside or cut back to reduce the conductor diameter to fit an undersized barrel.

The operator should discard any production crimp, which in his judgement is defective. This does not apply to test samples; no test sample shall be discarded.

Each operator shall prepare crimp joint samples for shift performance inspection at regular intervals, as detailed in subclause 8.8.2.

Tools at the operator's station shall be confirmed to be those selected in accordance with subclause 4.4 for compatibility with the parts to be crimped.

5.2.2 Connector barrel and single wire crimping

- a. Tools specified in MIL-DTL-22520 shall be used.
- b. Preference shall be given to the selection of single wire interconnections.
- c. Strands of wire shall not be doubled back to increase the conductor diameter.
- d. In special cases additional stranded wires may be used to increase the cross-sectional area up to a selected barrel size, provided that the insulation is prepared as normal and transparent “shrink-fit insulation” is used to cover the loose end of the wire to prevent any risk of a short circuit (see subclause 5.2.3).
- e. For 22 AWG up to 16 AWG wire sizes, the maximum insulation clearance shall be equal to the outside diameter (over the insulation) of the wire being used. The gaps for larger size wires shall not exceed 2 mm. No minimum gap is specified except that the conductor wire shall be visible to permit inspection. Where the terminal or contact is supplied with insulation support, the wire insulation shall enter the support to the extent that no bare wire is exposed.

Examples of crimping parameters are given in Table 1 (as a guideline) and an example of a typical connector barrel and single wire crimping is shown in Figure 6.

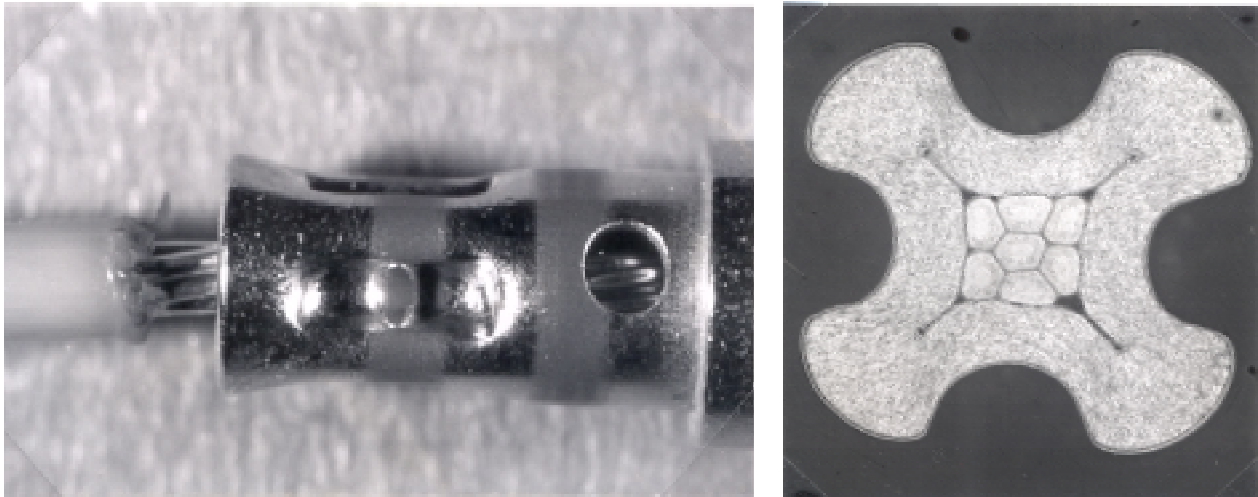

Figure 6: Example of a typical connector barrel and single wire crimping

**Table 1: Guideline for selector setting —
Four-indent crimp (dispersive)
Single wire — Crimping tool 22520/2-01**

Connector	Wire gauge (AWG)	Wire barrel contact size	Selector setting
S U B * D	18	20 - 18	5
	20	20 - 18	5
	20	20 - 20	7
	22	20 - 20	6
	24	20 - 20	5
	26	20 - 26	6
	28	20 - 26	6
	22	22 - 22	4
	24	22 - 22	3
3 8 9 9 9	12	12 - 12	8 G
	16	16 - 16	7 G
	18	16 - 16	6 G
	20	16 - 16	5 G
	20	20 - 20	7
	22	20 - 20	6
	24	20 - 20	5
	22	22 - 22	5
	24	22 - 22	4
	26	22 - 22	3
D B A S	12	12 - 12	8 G
	20	12 - 16	6 G
	16	16 - 16	6 G
	18	16 - 16	5 G
	20	16 - 16	4 G
	20	20 - 20	6
	22	20 - 20	6
	24	20 - 20	5
	26	20 - 26	5
	28	20 - 26	5
H E 8 0 1	22	22 - 22	5
	24	22 - 22	4
	26	22 - 22	4
NOTE: G = Setting of crimping tool 22520/1-01			

5.2.3 Connector barrel and multiple wire crimping

Although not generally recommended, crimping multiple wires into a single crimp barrel may be used as long as the following requirements are met.

- a. Tools specified in MIL-DTL-22520 shall be used.
- b. The maximum number of wires in one crimp barrel is limited to two.
- c. The sum of the two nominal conductor sections is compatible with the crimp barrel used (i.e. 2×24 AWG approximately equal to 1×20 AWG).
- d. Both conductors shall be of the same material and support the same plating finish (i.e. both silver and not a combination of silver and nickel).
- e. Before introduction into the barrel, where possible, wires or conductors may be twisted to obtain a "single" conductor.
- f. Axial strength measurements shall be performed on the two associated wires and the axial strength shall be as a minimum 75 % of the sum of the two wires axial strength requirements.
- g. Where appropriate, wires may be introduced into the barrel as separate conductors. When this method is used the actual strength measurement shall be performed on one of the wires (the smaller, if two different sizes are used) and the axial strength requirement shall be as quoted in Table 5 for the actual size of wire pulled, assuming a barrel size equal to that wire's gauge.

Examples of crimping parameters are given in Table 2 (as a guideline) and an example of a typical connector barrel and multi-wire crimping is shown in Figure 7.

**Table 2: Guideline for selector setting —
Four-indent crimp (dispersive)
Two wires — Crimping tool 22520/2-01**

Connector	Contact size	Combined wires (AWG)	Selector setting
S	20 - 18	20 + 22	6
U	20 - 18	22 + 22	5
B	20 - 20	24 + 24	6
*	20 - 20	24 + 24	6
D	20 - 20	22 + 24	6

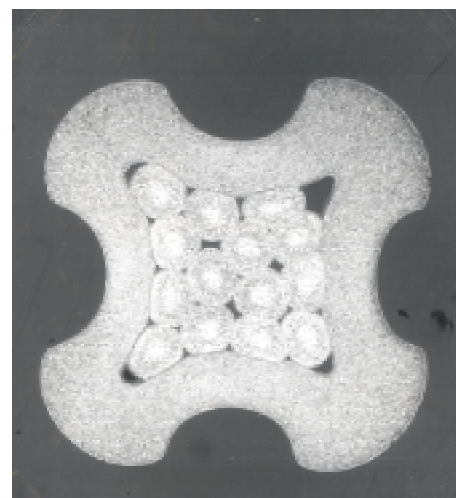
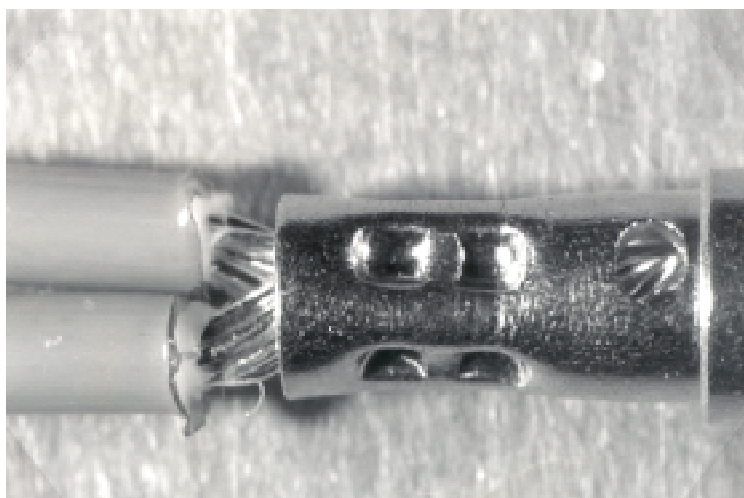

Figure 7: Example of a typical connector barrel and multi-wire crimping

5.2.4 Ferrule shield crimping

- a. Tools specified in MIL-DTL-22520 shall be used.
- b. The shielded wires on coaxial cables shall be braided.
- c. Axial strength measurements shall be performed only on the shield after removal of the core dielectric.
- d. Following crimping the assembly shall be protected by shrink tubing.

Examples of crimping parameters are given in Table 3 (as a guideline) and an example of a typical ferrule shield crimping is shown in Figure 8.

**Table 3: Guideline for die selection
(ferrule coaxial shield crimping)**

Coaxial connector ferrule	Coaxial cable	22520/5-01 tool die selection	22520/10-01 tool die selection
S U B * D	RG 178 BU	22520/5-03 B	22520/10-05 B
	50 CIS	22520/5-03 A	22520/10-05 A
	RG 180 BU	DANIELS Y 322 A	-
S M A	50 CIS	22520/5-03 A	22520/10-05 A

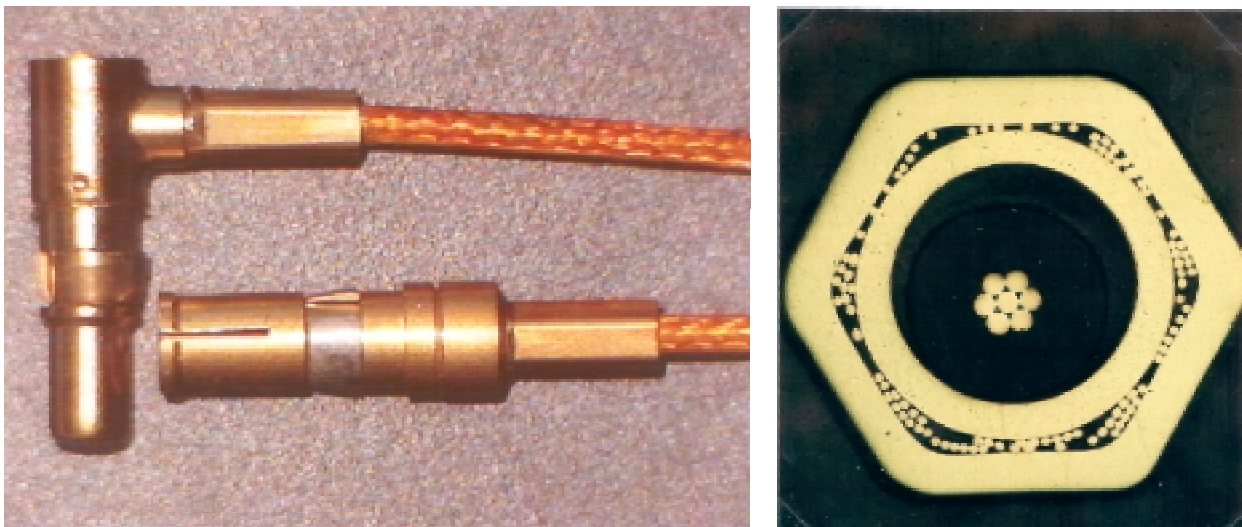

Figure 8: Example of a typical ferrule shield crimping

5.2.5 Lug and splice wire crimping

- a. Tools recommended by the manufacturer of the terminals shall be used.
- b. The maximum number of wires shall be limited to ten. (Seven wires maximum on the same side).
- c. All conductors shall be of the same material and within a size range of 4 wire gauges in the same side.
- d. All conductors shall be positioned parallel in the terminal before crimping.
- e. Axial strength measurements shall be performed on either
 1. all of the grouped wires, or
 2. on a single wire (the smallest) of the group.

In the case where opposed wires are tested a specifically designed test fixture shall be used. A typical test fixture is shown in Figure 9.

- f. Following crimping the assembly shall be protected by shrink tubing.
- Examples of typical lug and splice wire crimping are shown in Figure 10.

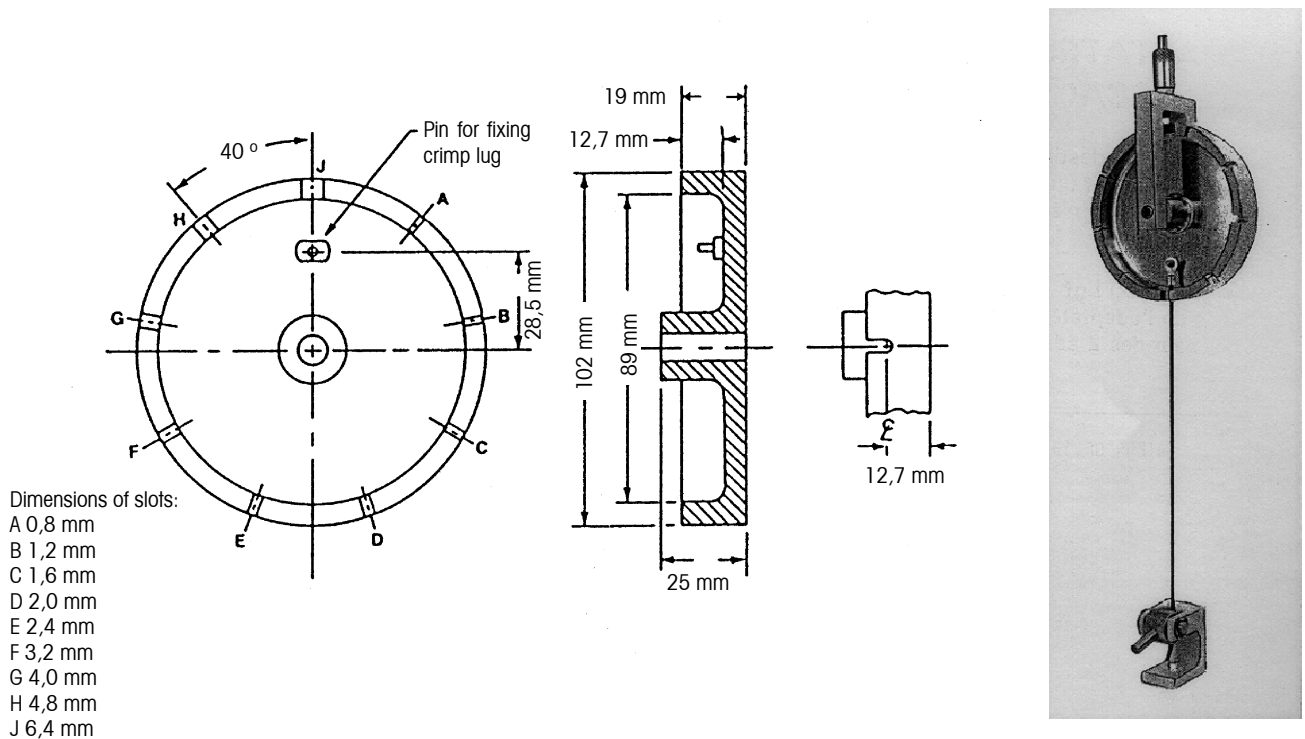

Figure 9: Typical test fixture for testing lug and splice crimps

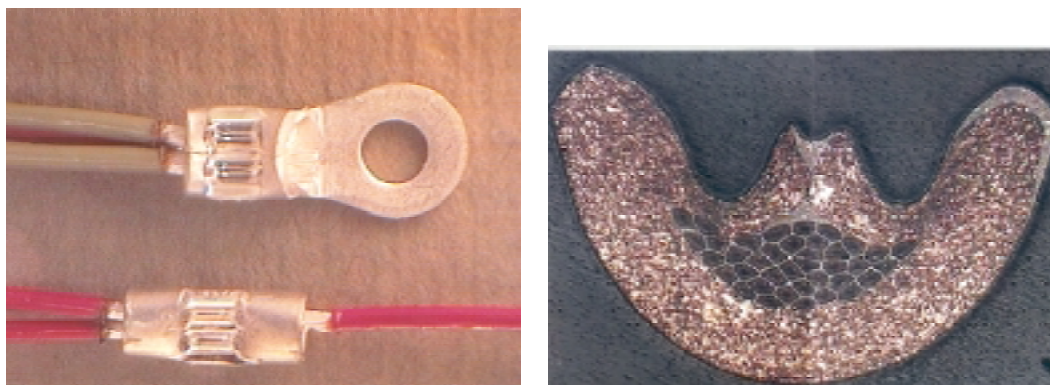
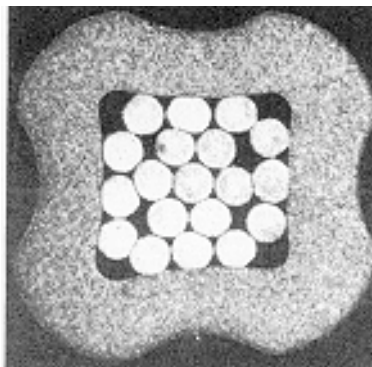
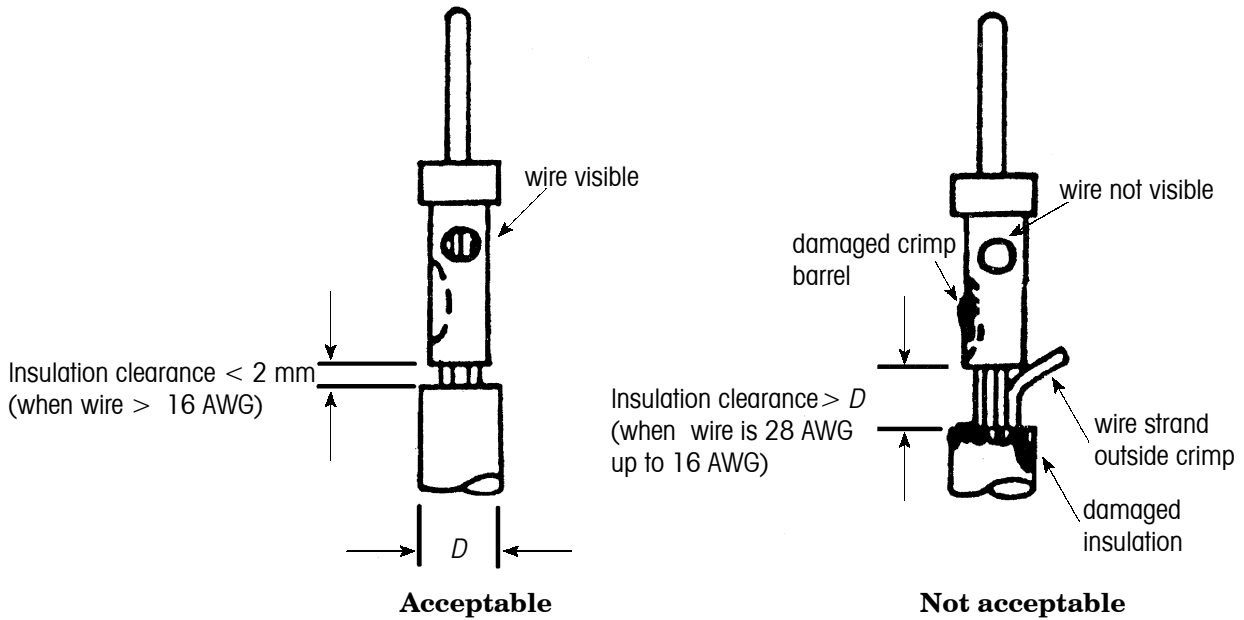

Figure 10: Examples of typical lug and splice wire crimping

5.3 Workmanship standards

The supplier shall prepare and have readily available visual standards consisting of satisfactory work samples or visual aids which clearly illustrate the quality characteristics of all crimped connections utilized. Defects such as those listed in subclause 7.1.1 and shown in Figure 11 shall be included as examples.



Unacceptable – undercrimp

- Voids greater than 10 %
- Wire not deformed

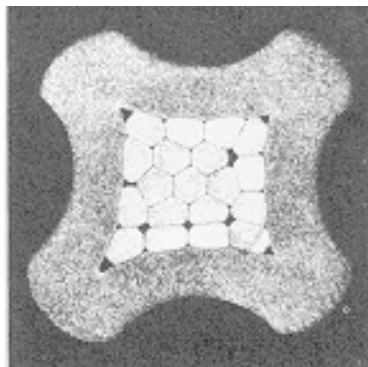

Acceptable

- All wire strands deformed
- Voiding less than 10 %

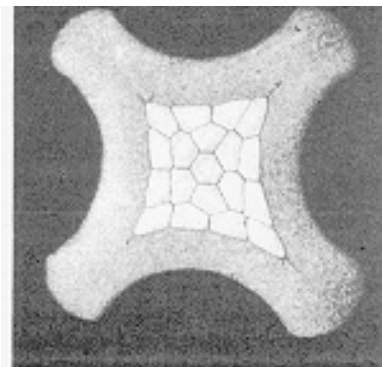

Preferred

Figure 11: Workmanship examples and crimp microsections

Test method

6.1 General

Samples shall be submitted to all or some of the tests detailed below. The number of samples is dependent on the specific process requirement (see subclauses 8.4.2, 8.5 and 8.8.2). Records of all results shall be tabulated in accordance with subclause 8.2. Prior to testing, the inspector shall also inspect the samples and apply to these the inspection criteria detailed in subclause 7.1.1.

6.2 Voltage-drop

The voltage-drop shall be measured from a point on the positioning shoulder of the contact to another point 14 mm distant on the attached wire (see Figure 12). In the case of two or more wires being crimped in the same contact, lug or splice, the voltage-drop measurement shall be performed on each wire. The voltage-drop of the contact crimp joint shall not exceed the value specified in Table 4 for each wire tested.

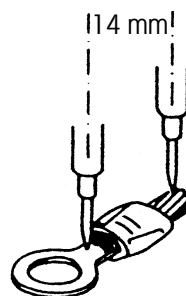

Figure 12: Measurement of voltage-drop across a crimped termination

Table 4: Voltage-drop test requirements

Wire barrel size	Wire size	Test current (A)	Maximum voltage-drop (mV)	
			Silver or tin-plated copper wire	Nickel-plated copper wire
0	0	150	3,0	4,5
4	4	80	4,0	4,0
6	6	60	4,5	-
8	8	45	3,0	3,5
10	10	33	4,0	-
12	12	23	3,0	X
	14	17	3,5	
	16	16	13	
18		9,0	4,0	
20		7,5	4,0	
20	20	7,5	4,0	
	22	5,0	4,0	
	24	3,0	4,0	
22	22	5,0	4,0	
	24	3,0	4,0	
	26	2,0	4,0	
24	24	3,0	4,0	
	26	2,0	4,0	
	28	1,5	5,0	
26	26	2,0	4,0	
	28	1,5	5,0	
28	28	1,5	5,0	

6.3 Tensile strength

6.3.1 General

The crimped contact-wire assemblies shall be placed in a tensile testing device whose calibration is accurate to 1 % of full-scale load, and an axial load applied at the rate of (25 - 50) mm/min \pm 2 mm/min. The connections shall be loaded until failure occurs. The value at failure shall be recorded, together with the information as to whether the failure was “pull-out”, “broke in crimp” or “break in wire”. The required ultimate axial strengths for compacted and dispersive crimped joints are shown in Table 5 and the following subclauses.

NOTE 1 The insulation may be stripped approximately 2 cm on test specimens to promote visual inspection of the mode of failure in the tensile test.

NOTE 2 The required ultimate axial strength values for crimped copper-alloy wire are calculated based on the requirement of a minimum wire strength of 343 N/mm².

6.3.2 Connector barrel wire crimping

- a. The required axial strength shall be as a minimum 75 % of the wire strength.
- b. Table 5 details the minimum requirements for axial strength for copper and copper-alloy wires having either silver-, tin- or nickel-plated finishes.

Table 5: Required ultimate axial strength for compactive and dispersive crimped joints

Wire barrel	Wire size (AWG)	Axial strength (Newton)		
		Silver- or tin-plated copper wire	Nickel-plated copper wire	Copper-alloy wire
0	0	3120	2800	-
	2	2450	2200	-
2	2	2450	2200	-
	4	1780	1600	-
4	4	1780	1600	-
	6	1330	1200	-
6	6	1330	1200	-
	8	980	890	-
8	8	1250	1150	-
10	10	710	-	-
	12	500	-	-
12	12	500	-	-
	14	320	-	-
16	16	230	-	-
	18	155	-	-
	20	90	-	-
20	20	90	-	185
	22	60	-	115
	24	40	-	60
22	22	60	-	115
	24	40	-	60
	26	-	-	45
24	24	40	-	60
	26	-	-	45
	28	-	-	30
26	26	-	-	45
	28	-	-	30
28	28	-	-	30

NOTE 1 Wire barrel size < 6 AWG tools are without adjustable setting.

NOTE 2 Wire barrel sizes ≥ 8 AWG tools are generally with adjustable settings which permit optimized crimped joints having higher axial strengths.

6.3.3 Ferrule, lug and splice crimping

The required axial strength shall be as a minimum

- 70 % of the shield strength,
- 70 % of one of the smallest gauge wires within the connection if pulled individually, or
- 70 % of the sum of all the wires axial strength requirements if all wires are pulled together.

6.4 Metallography

The joint to be sectioned shall be mounted in a low exotherm resin capable of being moulded without the application of external pressure. The joint shall be so oriented that the wire is perpendicular to the polishing surface. The specimen shall be ground with the aid of the appropriate grades of silicon carbide papers to expose the mid-section of the joint. This section shall then be polished with successively finer grades of diamond paste down to $1\ \mu\text{m}$. To aid microscopic examination, the polished section shall later be very lightly etched with an appropriate chemical reagent specific to the composition of the materials being crimped.

Acceptance criteria

7.1 Validation and qualification testing

7.1.1 Visual inspection

During visual inspection the following acceptance criteria shall be met; failure to meet the acceptance criteria shall be cause for rejection.

- a. Insulation is not damaged by the crimping tool or the terminal.
- b. The conductor is visible in the inspection hole when an inspection hole is provided.
- c. The crimp barrel has no unintentional sharp edges, peeled metal, burrs, cracked platings or cuts after crimping. All functional parts, including all retention clips or locking devices, are operational after the crimp has been made.
- d. No tarnished or corroded contacts are present.
- e. No misplaced crimps, as determined by marks found on areas not designed to take crimping, are present.
- f. No undercrimps or overcrimps (e.g. an undercrimp detected by a loose conductor or an overcrimp detected because of broken strands or deformed wire at end of terminal) are present. If detected this shall be cause to stop operations at that station, to reject all production crimps made since the last verification or pull test and to investigate tool, wire and terminals for the cause of failure.
- g. No bent contacts are present.

7.1.2 Voltage-drop test

The acceptance criteria for the voltage-drop test are given in Table 4.

7.1.3 Tensile strength test

The measured values for ultimate axial strength shall conform to those listed in Table 5 and subclauses 6.3.2 and 6.3.3.

7.1.4 Metallography

The section shall be examined in both as-polished and etched states using a metallographic microscope at a suitable magnification up to $\times 400$.

- a. Each microsection shall be free from contamination.

- b. The crimp barrel shall be evenly deformed.
- c. Voids shall occupy less than 10 % of the cross-sectioned area of the wire volume.
- d. The wires and barrel should appear as a gas-tight joint or conform to the workmanship sample prepared during qualification or validation of the specific crimp connection.
- e. All wires shall be deformed from their circular cross-section.
- f. There shall be no indentations or fracturing of the deformed receptacle barrel or its plated finish.

NOTE 1 For ferrule shield crimping the requirements of c. and e. are not applicable.

NOTE 2 For wire barrel contact size 20 - 18 the requirement c. is not applicable due to localized voiding at the crimp corners.

7.2 Shift performance test

Samples shall be submitted to visual inspection and tensile tests (as detailed in subclause 8.8.2). If any sample fails to meet the acceptance criteria all production crimps produced by the crimp tool concerned subsequent to its last shift performance sampling shall be rejected.

Quality assurance

8.1 General

The quality assurance requirements are defined in ECSS-Q-20. Particular attention shall be given to the following points (see also Figure 13).

8.2 Data

The quality records (e.g. logbooks) shall be retained for at least ten years or in accordance with project contract requirements, and contain as a minimum the following.

- the as-built and test configuration list (waiver and deviation summary);
- nonconformance reports and corrective actions;
- copy of the visual inspection and shift performance test results with reference to the relevant procedure, personnel and tools used;
- records of the training, testing and certification status of crimping operators (see subclause 8.7) and ECSS-Q-70-08A, subclause 14.8.

8.3 Nonconformance

Any nonconformance which is observed in respect of the process shall be dispositioned in accordance with the quality assurance requirements, see ECSS-Q-20-09. Furthermore, failure of a crimping tool to pass any requirement specified in subclause 4.4.1 shall require rejection of all crimps made by that tool since it was last tested successfully for acceptance.

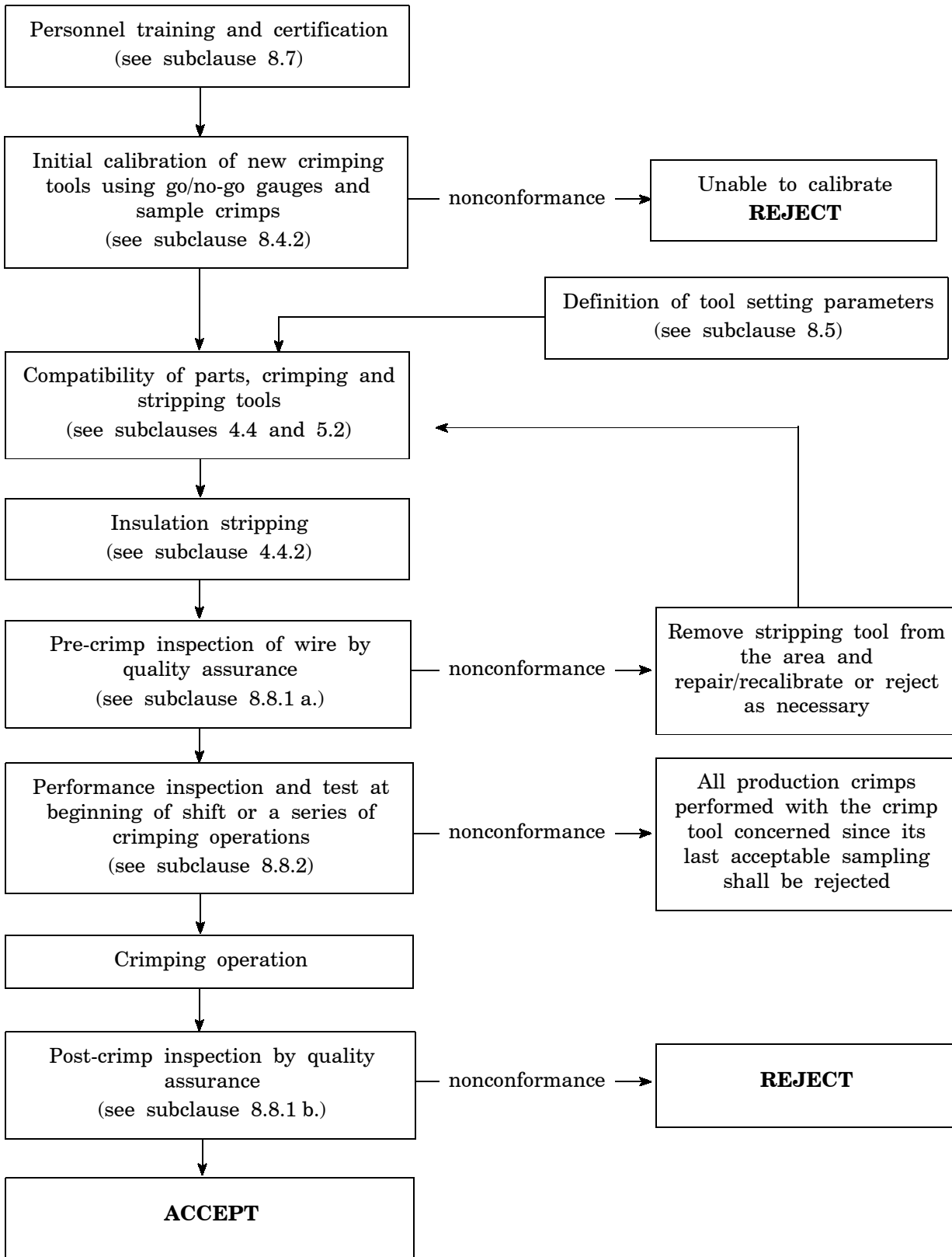

Figure 13: Guide to quality controls during crimping operation

8.4 Calibration of crimping tools

8.4.1 General

Each crimping tool and piece of measuring equipment shall be calibrated as indicated below. Moreover, any suspected or actual equipment failure shall be recorded as a project nonconformance report so that previous results can be examined to ascertain whether or not re-inspection or retesting is required. The customer shall be notified of the nonconformance details.

The supplier's calibration procedure shall include all the requirements specified in this subclause.

8.4.2 Validation

Crimping tools, both manual and powered, shall be calibrated when initially set up for each specific wire size, connection size and type prior to first issue. The setting by the tool manufacturer shall not be relied on. The tool shall be calibrated according to the following checking operations:

- cleanliness control of the active part of the tool (e.g. indenters);
- correct position of the indenters with the aid of a profile projector (e.g. misalignment $\leq 0,05$ mm for 22520/2-01 tool);
- set up with the aid of the "go/no-go" gauge according to specified conditions;
- tests according to clause 6 on not less than four samples.

After satisfactory results the calibration tool status is declared acceptable. A corresponding "tool calibration sheet" shall be established to ensure tool traceability.

This traceability shall be established by periodic analysis of the corresponding data issued from the shift performance inspection and tests (subclause 8.8.2), the frequency is defined in relation to production activity such as six months or 2500 crimping operations.

A significant drift in test results shall result in tool rejection (out-of-calibration tool).

8.4.3 Sealing and marking

Calibrated crimping tools shall be sealed to ensure against unauthorized alteration of adjustment settings. A wire and lead seal method shall be used if the tool has provisions for it; otherwise the tool shall be sealed by a non-reusable decal seal which, if the calibrated setting is altered, is visibly damaged. Seals shall be placed on all external adjustment points of the tool.

8.4.4 Out-of-calibration tools

A tool that is out of calibration for any reason (e.g. a tool which has been dropped) shall be returned to the tool facility for readjustment and calibration. Tools that are worn or damaged so that they cannot hold a setting shall be identified as rejected and removed from the fabrication area.

8.5 Requirements for new crimp configurations

8.5.1 General

Crimp configurations or designs that are not contained in this Standard shall be subjected to the following tests in order to determine the optimum operation parameters.

8.5.2 Test procedure

- a. The settings recommended by the crimping tool manufacturer may be used as a starting point for calibrating tools. Ten samples shall be prepared at this point and pulled; the tool indenter opening shall then be varied in convenient increments above and below this point, and ten samples pulled at each increment. The minimum in voltage-drop and maximum in tensile strength shall be determined and evaluated as per Figure 14. The design value or operating point should lie approximately in the middle of the flat top portion of the tensile-strength plot (see Figure 14 for an example).
- b. When a previously undocumented contact and wire combination is proposed for use, a plot as delineated above shall be made, increments being close enough together to obtain a smooth curve. From this plot, an optimum setting can be chosen approximately in the middle of the flat top portion of the tensile-strength curve. This point is the operating point for the tools with that specific combination of contact and wire and shall be entered in the process records.
- c. Voltage drop tests shall be performed on five samples corresponding to the operating point.
- d. Metallography tests shall be performed on a minimum of three of these samples corresponding to the operating point.
- e. The remaining samples shall be retained for reference.
- f. This approach is conducted from the variation of the main parameter involved to the relevant terminal crimping.
 - Connector barrel crimping: selector setting;
 - Ferrule crimping: die selection;
 - Lug and splice crimping: total cross-section of stranded wires.

8.5.3 Sealing and marking

See subclause 8.4.3.

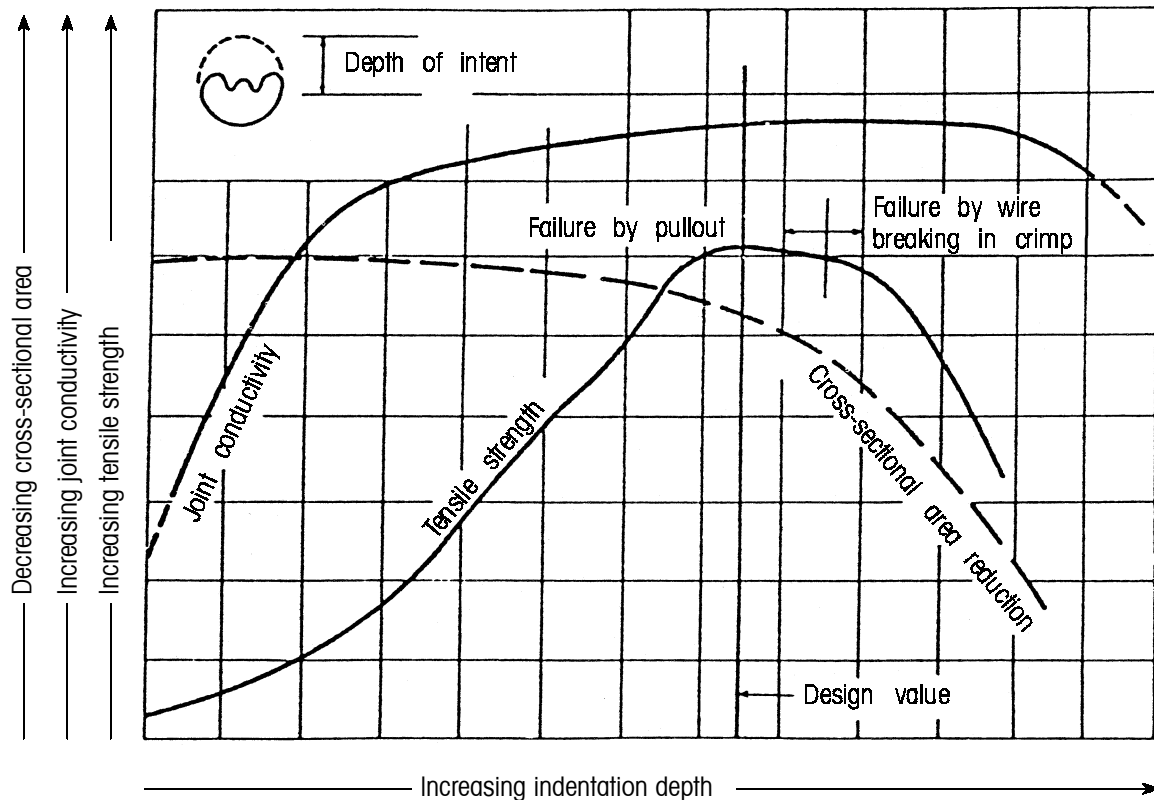

Figure 14: Typical plots showing variation in crimp termination characteristics with increasing indentation depth

8.6 Traceability

Traceability shall be maintained throughout the process from incoming inspection to final test, including details of test equipment, tools and personnel employed in performing the task.

8.7 Personnel training

Trained and competent personnel shall be employed for all crimping operations. A training programme shall be developed, maintained and implemented to provide for excellence of workmanship and personnel skills, careful and safe operations, and improvement of the quality of crimped joints.

Trained personnel, performing crimping operations, shall be certified. The certification of personnel shall be based upon objective evidence of crimp quality, resulting from test and inspection of the crimped joints. Re-certification of personnel shall apply in cases of repeatedly unacceptable quality levels and changes in crimping techniques, parameters or required skills.

Records shall be maintained of the training and certification status of crimping operators and inspection personnel.

All training and certification shall only be performed at a school authorized by the final customer.

8.8 Inspections

8.8.1 Visual inspection (performed by operator)

a. Pre-crimp inspection

Before the stripped wire is inserted into the contact or terminal barrel, the wire shall be examined for nicks, rings, broken strands, untwisted lay or unremoved insulation in the area of the crimp. Damaged wires where the base material is exposed shall not be used. Contacts and terminal barrels that show evidence of the presence of tarnish, corrosion or physical damage, including bent contacts, shall not be used.

Inspection shall verify that wire size and type and the contact or terminal are as specified in the drawing or control document.

b. Post-crimp inspection

The inspection shall be carried out with the aid of a binocular microscope having an initial linear magnification no greater than $\times 7$. Further examination of surface characteristics can be performed at higher magnifications. Parts and conductor leads shall not be physically disturbed to aid inspection. The acceptance criteria are described in subclause 7.1.

8.8.2 Shift performance inspection and test

At the beginning of a shift or before a series of crimping operations, each operator shall prepare four samples. At the end of the operation four further samples shall be crimped.

Alternatively, a logbook shall be kept for each tool. The logbook shall show the quantity of parts crimped since each calibration and since each go/no-go operation. Four samples shall be crimped after each 100 crimping operations have been performed.

A tool shall be changed whenever a wire size or contact size is changed. The operator shall prepare four samples at the start of the operation after such a change.

This may be omitted if samples have already been prepared by the tool during the shift.

In each case three samples shall be submitted to the tensile strength test detailed in subclause 6.3. The test requirements are given in subclause 7.1.3.

The fourth sample shall be retained for reference and traceability purposes (subclause 8.4.2).

Analysis of shift performance test results, in comparison with initial tool calibration results, shall be used to determine any drift in tool performance.

ECSS Document Improvement Proposal		
1. Document I.D. ECSS-Q-70-26A	2. Document date 13 February 2001	3. Document title Crimping of high-reliability electrical connections
4. Recommended improvement (identify clauses, subclauses and include modified text or graphic, attach pages as necessary)		
5. Reason for recommendation		
6. Originator of recommendation		
Name:	Organization:	
Address:	Phone: Fax: e-mail:	7. Date of submission:
8. Send to ECSS Secretariat		
Name: W. Kriedte ESA-TOS/QR	Address: ESTEC, P.O. Box 299 2200 AG Noordwijk The Netherlands	Phone: +31-71-565-3952 Fax: +31-71-565-6839 e-mail: wkriedte@estec.esa.nl

Note: The originator of the submission should complete items 4, 5, 6 and 7.

This form is available as a Word and Wordperfect-Template on internet under
<http://www.estec.esa.nl/ecss/improve/>

(This page is intentionally left blank)